

	<h1>Product Specification</h1>	Specification Number	A384-500
		Revision	01

Part No. A384-500

Description Drum Trolley (for drums up to 500mm diameter)

Material of Construction: Frame: 304 stainless steel
Wheel Mounts: 304 stainless steel
Wheels: Polyamide

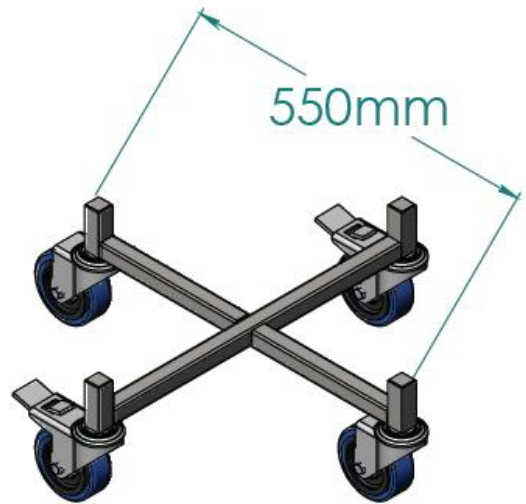
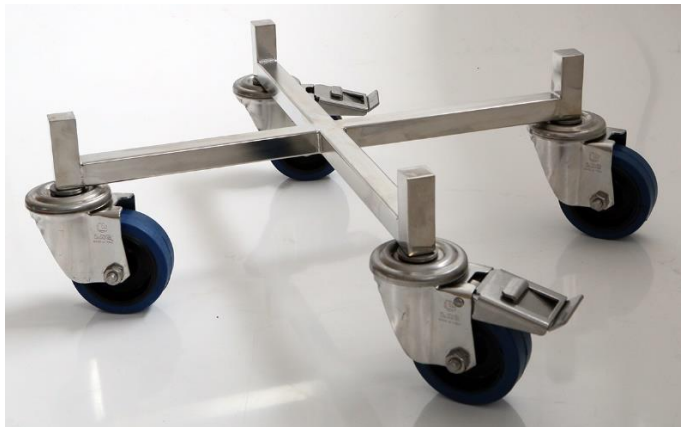

Method of Construction: Frame - welded

Surface Finish: Brush finish

Max. Frame Width: 550mm

Deck Height 135mm

Nominal Weight: 7kg

Notes:

- All four wheels are able to swivel
- Two wheels are fitted with brakes

Specification Approved By:	Signature: 	Name: Kuldeep Flora Position: Quality Manager Date: 9-Jul-19
Page 1 of 1	Sampling Systems Ltd. 4-5 Forge Mills Park, Station Road, Coleshill. Warwickshire. B46 1JH. UK. Tel: +44(0)1675 466992 Email: info@sampling.com Web: www.sampling.com	