

**1. Part Number:** A196-30

**2. Photograph:**

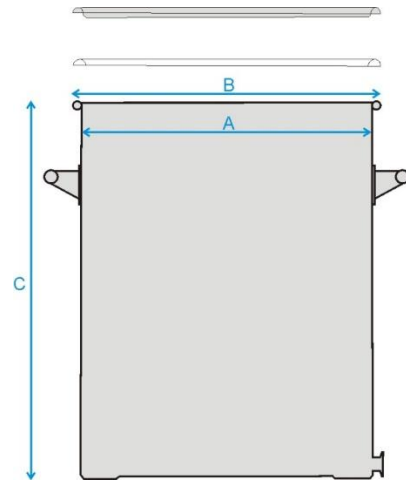

**3. Product Information:**

Description

Stainless Storage Drum 30L with 1" Ferrule

Materials of Construction:

- Body: 316L stainless steel
- Ferrule: 316L stainless steel
- Lid: 316L stainless steel
- Clamp: 304 stainless steel
- Handles: 304 stainless steel
- Gasket: Silicone (FDA 177.2600 and USP Class VI compliant)

Nominal Volume:

30 Litres

Method of Construction:

Welds ground and polished

Surface Finish:

Better than 0.5 microns Ra

Dimensions

A = 300 mm  
B = 320 mm  
C = 450 mm

Graduation Marks:

None

Ferrule:

1" (to standard BS4825-3)

Ferrule location

25mm from base to underside of ferrule

Handles:

2 side handles welded onto patch plates

Weight:

6.6 Kg (body + gasket + lid + clamp)

BSE/TSE statement:

All polishing compounds used in the manufacture of this product are of vegetable origin

Recommended Storage Conditions:

Dry and ambient temperature

Note: This product should be thoroughly cleaned before it is used for the first time

**4. Approval:**

Signed:



Name: Kuldeep Flora

Position: Quality Manager

Date: 2-Mar-22



**Sampling Systems Ltd.**

4-5 Forge Mills Park, Coleshill, Warwickshire, B46 1JH, UK.  
Tel: +44(0)1675 466992 Email: info@sampling.com Web: www.sampling.com