



Improve your Indoor Air Quality with UVC Air Purification

Ensure that you and your family are breathing clean air with the power of UVC technology. Simple to use and easy to install, this system mounts onto your existing forced air furnace.



10 YEAR WARRANTY

Effectively Purifies up to **3500 Sq. Ft.**

PRODUCT FEATURES

- Lamps produce no ozone
- Energy efficient electronic ballast
- Safety feature designed to prevent accidental exposure to UVC light
- Built-in lamp replacement indicator (Replace lamp once a year for optimal performance)
- Safely purifies home up to 3500 sq. ft.
- Installs in less than 15 minutes



Compact and easy to install



Provides clean fresh air for the entire home



Kills germs that cause colds and flu



Alleviates allergies and asthma symptoms

OPTIONAL INSTALLATION LOCATIONS ON FORCED AIR FURNACE

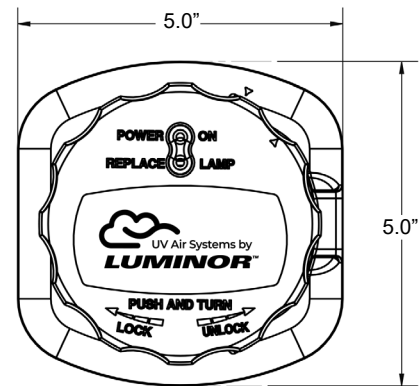
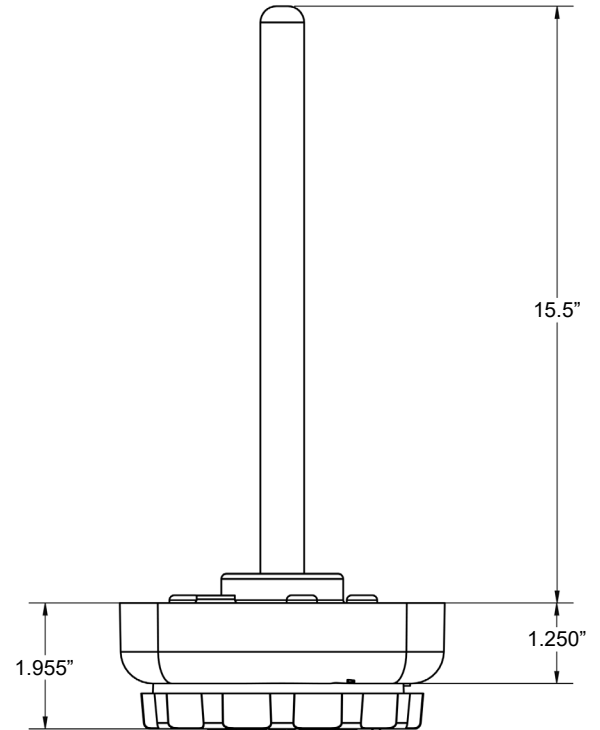
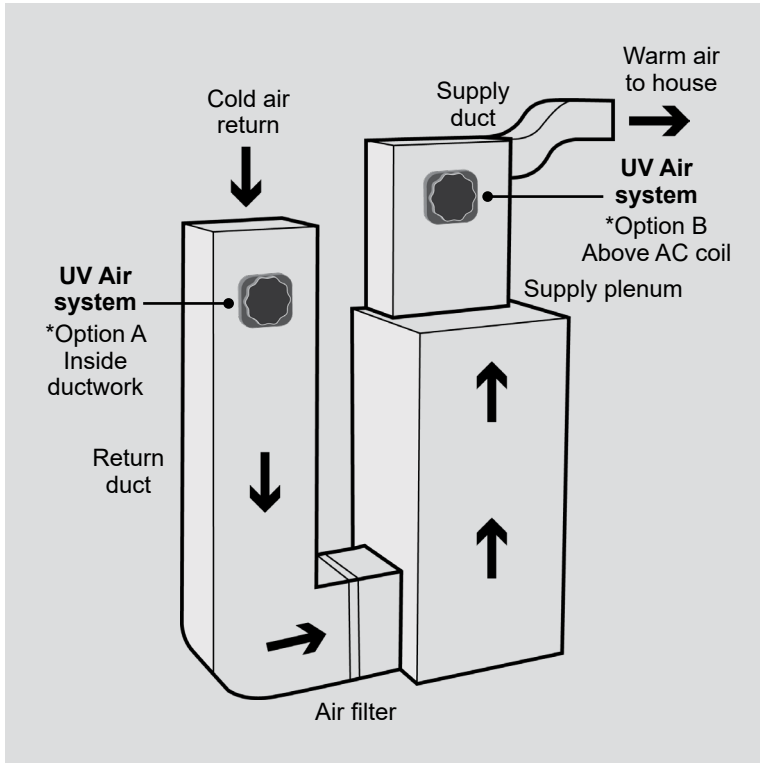

PRODUCT SPECIFICATIONS	UVAIR-01
INPUT SUPPLY VOLTAGE	108-132V
INPUT SUPPLY FREQUENCY	60 Hz
POWER (WATTS)	36
PRIMARY AMPERES	0.55A
OPERATING TEMPERATURE	-5 °C to 75 °C
OPERATING RELATIVE HUMIDITY	90%
POWERHEAD DIMENSIONS	5"(w) x 5" (h)
REPLACEMENT LAMP	UVAIR-RL1
LAMP CHANGE REMINDER	YES
LAMP OUT INDICATOR	YES
SHIPPING WEIGHT	1.0 kg (2.2 lbs)

MANUFACTURER'S WARRANTY

Ten (10) year Limited Warranty on the powerhead, from the date of original purchase, or installation.

See website for LUMINOR's complete warranty document including conditions and exclusions.



EPA Establishment
#088776-CAN-001



ERE INC
8605 rue Champ d'Eau
St. Leonard QC, H1P 3B8 Canada
Tel: (514) 326-8852
Fax: (514) 326-8961
www.ereinc.com