

Digital Drum

Owner's Manual

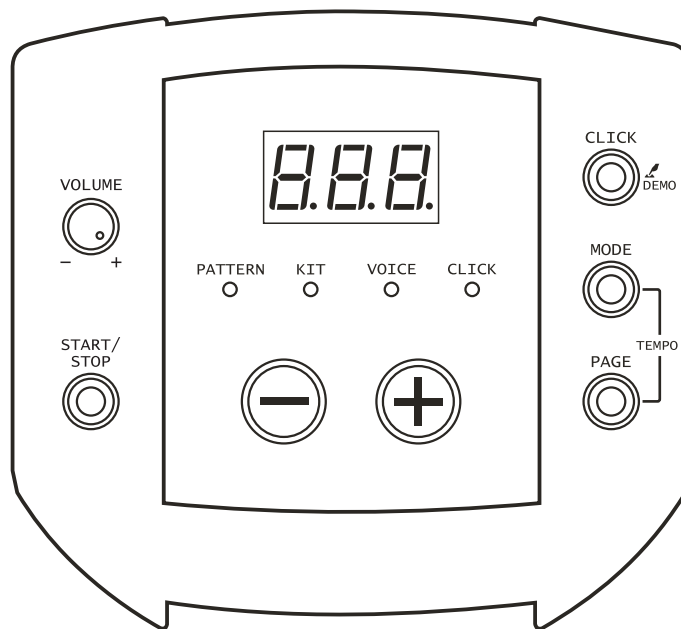

INFORMATION FOR YOUR SAFETY!

THE FCC REGULATION WARNING (for USA)

This equipment has been tested and found to comply with the limits for a Class B digital device, pursuant to Part 15 of the FCC Rules.

These limits are designed to provide reasonable protection against harmful interference in a residential installation. This equipment generates, uses, and can radiate radio frequency energy and, if not installed and used in accordance with the instructions, may cause harmful interference to radio communications. However, there is no guarantee that interference will not occur in a particular installation.

If this equipment does cause harmful interference to radio or television reception, which can be determined by turning the equipment off and on, the user is encouraged to try to correct the interference by one or more of the following measures:

- Reorient or relocate the receiving antenna.
- Increase the separation between the equipment and receiver.
- Connect the equipment into an outlet on a circuit different from that to which the receiver is connected.
- Consult the dealer or an experienced radio/TV technician for help.

Unauthorized changes or modification to this system can void the user's authority to operate this equipment.

CAUTION

The normal function of the product may be disturbed by Strong Electro Magnetic Interference. If so, simply reset the product to resume normal operation by following the owner's manual. In case the function could not resume, please use the product in other location.

CAUTION

Changes or modifications not expressly approved by the party responsible for compliance could void the user's authority to operate the equipment.

PRECAUTIONS

PLEASE READ CAREFULLY BEFORE PROCEEDING

Please keep this manual in a safe place for future reference.

Power Supply

Please connect the designated AC adaptor to an AC outlet of the correct voltage.

Do not connect it to an AC outlet of voltage other than that for which your instrument is intended.

Unplug the AC power adaptor when not using the instrument, or during electrical storms.

Connections

Before connecting the instrument to other devices, turn off the power to all units. This will help prevent malfunction and / or damage to other devices.

Location

Do not expose the instrument to the following conditions to avoid deformation, discoloration, or more serious damage:

- Direct sunlight
- Extreme temperature or humidity
- Excessive dusty or dirty location
- Strong vibrations or shocks
- Close to magnetic fields

Interference with other electrical devices

Radios and televisions placed nearby may experience reception interference. Operate this unit at a suitable distance from radios and televisions.

Cleaning

Clean only with a soft, dry cloth.

Do not use paint thinners, solvents, cleaning fluids, or chemical-impregnated wiping cloths.

Handling

Do not apply excessive force to the switches or controls.

Do not let paper, metallic, or other objects into the instrument. If this happens, unplug the AC adaptor from the wall outlet. Then have the instrument inspected by qualified service personnel.

Disconnect all cables before moving the instrument.

Panel Description

| | |
|-------------------|---|
| Front Panel | 4 |
| Rear Panel | 4 |

Setup

| | |
|--------------------------------------|---|
| Connect the pads and the pedal | 5 |
|--------------------------------------|---|

Connections

| | |
|--|---|
| Connect an audio equipment | 6 |
| Connect a CD player, etc.(Aux in jack) | 6 |
| Connect headphones | 6 |
| Connect the power supply jack | 6 |
| MIDI and USB | 6 |

MENU

| | |
|-----------------|---|
| menu tree | 7 |
|-----------------|---|

Operation

| | |
|---------------------------|---|
| Switch the power ON | 7 |
| Set the main volume | 7 |

Pattern

| | |
|---------------------------------------|---|
| Select a pattern | 8 |
| Adjust the accompaniment volume | 8 |
| Adjust the drum volume | 8 |

Drum Kit

| | |
|-----------------------------|---|
| Select a kit | 9 |
| Adjust the kit volume | 9 |

| | |
|----------------------------|---|
| Switch reverb on/off | 9 |
|----------------------------|---|

Voice

| | |
|-------------------------------|----|
| Select the voice | 10 |
| Adjust the voice volume | 10 |
| Adjust the midi note | 11 |

Tempo

| | |
|------------------------|----|
| Adjust the tempo | 11 |
|------------------------|----|

Click

| | |
|---------------------------------------|----|
| Adjust the click time signature | 12 |
| Adjust the click interval | 12 |
| Adjust the click instrument | 12 |
| Adjust the click volume | 12 |

Restore the factory preset

Play the demo

Play the pattern

Play the click

Appendices

| | |
|----------------------------------|----|
| Specifications | 14 |
| Preset Drum Kit List | 15 |
| Drum Instrument List | 15 |
| Preset Pattern List | 15 |
| GM Backing Instrument List | 16 |
| GM Drum Kit List | 18 |
| MIDI Implementation Chart | 19 |

Panel Description

Front Panel

1 MASTER VOLUME KNOB

Control the volume of phone and line output.
Turn it clockwise to increase the volume and anticlockwise to decrease it.

2 [START/STOP] BUTTON

Start or stop Pattern playing.

3 3-DIGIT LED DISPLAY

3 digit-LED and LED indicators.

4 [CLICK] BUTTON

Press [click] button to start/stop the click.

Hold on the [click] button 2 seconds to enter the demo mode and play the demo.

5 [MODE] BUTTON

Press [mode] button to select the mode from PATTERN, KIT, VOICE, CLICK.

6 [PAGE] BUTTON

Press [page] button to browse the menu pages of current selected mode.

Press both [mode] and [page] buttons, the 3-digit-LED will display the tempo page, it will temporarily display for 3 seconds, then press [+] or [-] to adjust the value.

7 [+] / [-] BUTTON

Press [+] / [-] button to adjust the parameters.

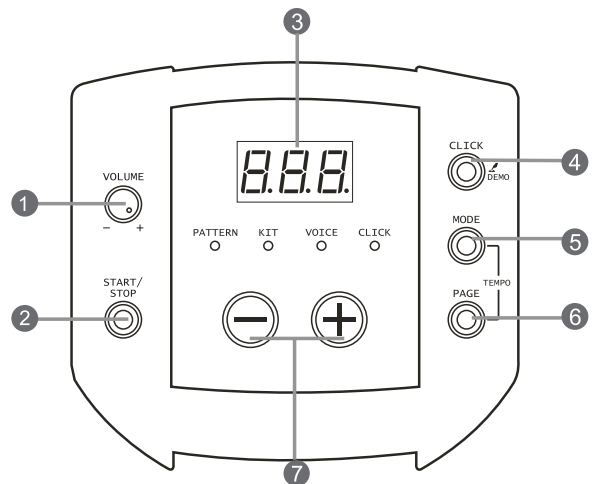

Rear Panel

8 POWER SUPPLY JACK (DC in 9V)

Connect an AC adaptor to this jack.

9 POWER SWITCH

Turn the power on/off.

10 USB PORT

Connect to computer.

11 MIDI OUT JACK

Connect with external sound module.

12 LINE OUTPUT JACKS (R, L/MONO)

made up of right channel output and left channel output which is also used as mono line output.

13 AUX IN

Connect with external sound source.

14 PHONES JACK

Connect a pair of stereo headphones to this jack.
(Connect the headphones will not mute the output jacks.)

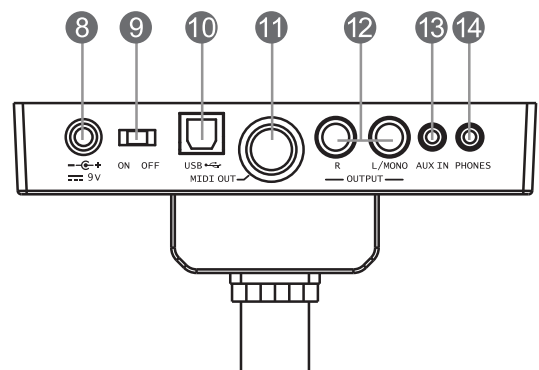

Caution!

To prevent electric shock and damage to the device, make sure the power is switched OFF on the drum and all related device before making any connection.

Connect the pads and the pedal

Using the provided cables, the cable received by marking the corresponding drum pads, cymbal pads Bass Drum and pedal. (See the below illustration for reference)

Note:

1. The voice of hi-hat pad hitting is controlled by hi-hat pedal. Similar to a real drum kit, the hi-hat pad functions as an 'open hi-hat' when the pedal is released. When the pedal is stepped, it functions as a 'closed hi-hat'.
2. The valid striking area of a cymbal pad (ride, crash or hi-hat) is near the edge of the pad, which is different from other pads.

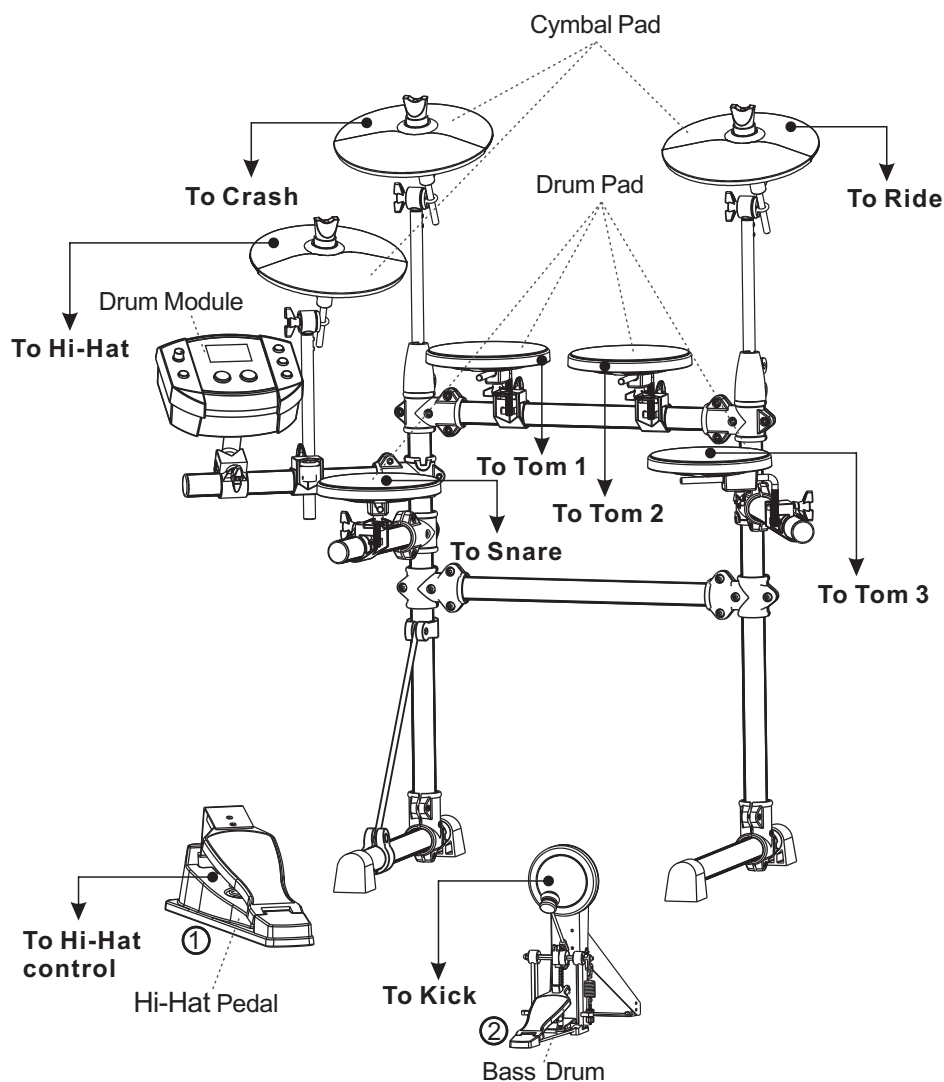

Connections

Connect an audio equipment

1. When you want to listen to the voices with an amplifier, connect amplifiers with the Output L/MONO and R jacks on the rear panel. (For monaural playback, use the L/MONO jack; for stereo playback, connect both L/MONO and R jacks.)
2. The volume is adjusted with the VOLUME knob.

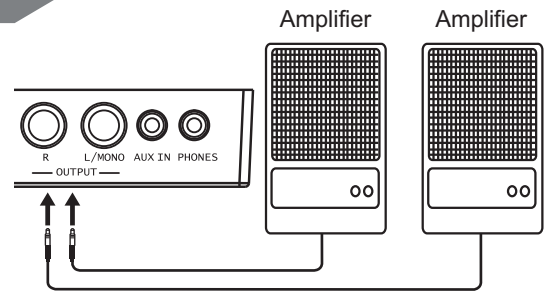

Connect a CD player, etc.(Aux. In jack)

1. The audio output of a CD player, or other audio source, to connect with the AUX IN jack on the rear panel can be mixed with the sound of the drum. This function is that let you play along with a favourite song.
2. The volume of the external signal is adjusted with the VOLUME knob.

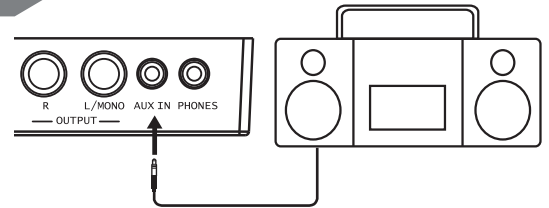

Connect headphones

An optional set of stereo headphones can be connected with the PHONES jack located on the rear panel of the drum module.

- * Adjust the volume to a comfortable level.

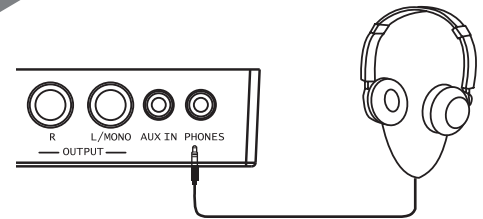

Connect the power supply jack

Make sure the power is switched OFF and connect the power adaptor with the DC IN jack on the rear panel.

Note:

1. To protect the speakers, amplifier and the drum module from damage, rotate the volume knob to the minimum volume level before switching the power ON.
2. Make sure the power is switched OFF when connecting drum module with external devices.

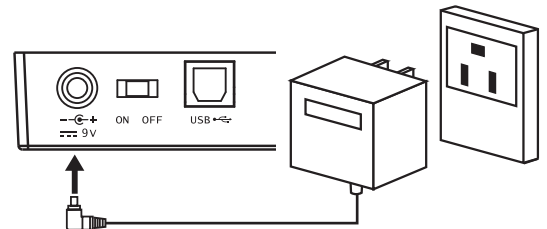

MIDI and USB

MIDI stands for Musical Instrument Digital Interface, this is a world-wide standard communication interface that enables electronic musical instruments and computers (of all brands) to communicate with each other so that MIDI command and other data can pass between them. This exchange of information makes it possible to create a system of MIDI instruments and devices that offer far greater versatility and control than is available with isolated instruments. Whether you interface with computers, sequencers, expanders or other controllers, your musical horizons will be greatly enhanced.

MIDI connection

MIDI OUT: This terminal transmits data from this instrument to other MIDI devices.

USB connection

The USB connector allows you to connect the module directly to your computer. It can be connected without driver installation under the Windows XP\ Vista\Windows 7 & MAC OSX environment. The module will be recognized as 'USB Audio device' to receive and transmit MIDI messages through a single USB cable, USB is used only for MIDI messages (MIDI via USB).

Note: When the USB is connected to a computer, all MIDI messages will be received and transmitted via USB.



Menu tree

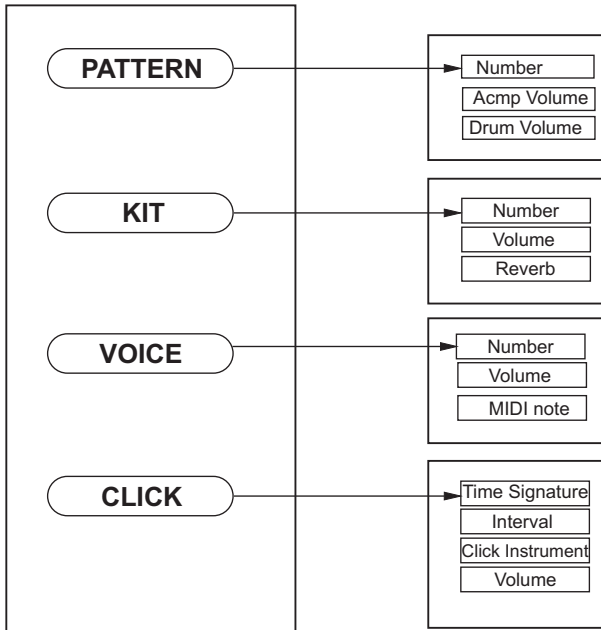

In the main menu there are 4 menu items

- PATTERN
- DRUM KIT
- VOICE
- CLICK

Operation

Press [MODE] button to change the mode.
 Press [PAGE] button to select the page of current mode.
 Press [+] / [-] button to adjust the parameters.

Switch the power ON

After confirming all connection have been completed, rotate the volume knob to the left (minimum volume level) before switching the power on.

Set the power switch to "ON" position to switch on the power.
 Display shows the kit's number and its indicator lights up.

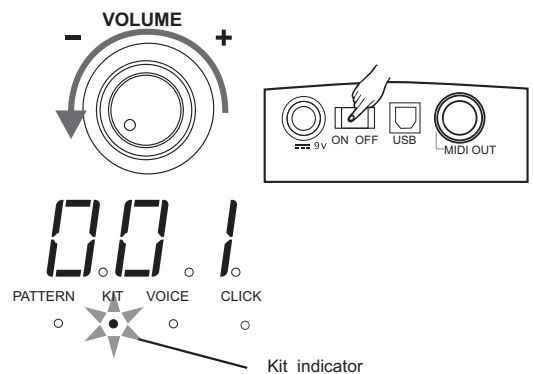

Set the main volume

While hitting a pad, gradually rotate the volume knob until a comfortable volume level is reached.

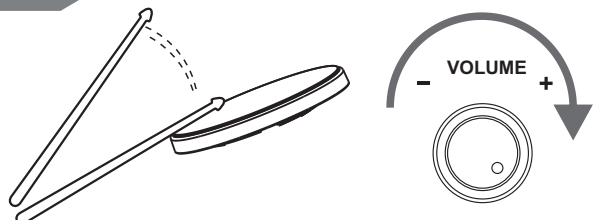

Pattern

In pattern mode, there are 3 pages:

1. Pattern number (1- 40, default 1)
2. Pattern accompaniment volume(0-32)
3. Pattern drum volume(0-32)

Select a pattern

In pattern mode, Pattern number (001-040, default 001)

1. Press the [MODE] button to select the pattern mode, the pattern LED indicator will be lighted up, the 3-digit-LED will display the pattern number(001)
2. Press [+] or [-] button to adjust the value.
Range :(001 to 040)

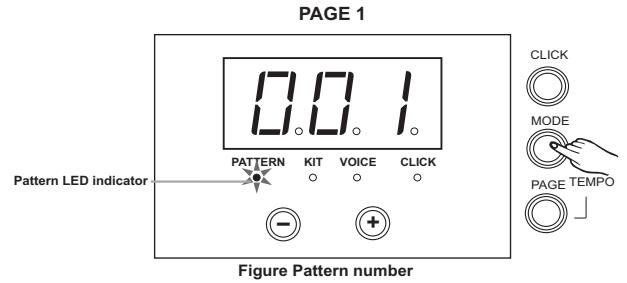

Adjust the accompaniment volume

In pattern mode, pattern accompaniment volume(0-032)

1. Press [MODE] button to select the pattern mode, the pattern LED indicator will be lighted up.
2. Press [PAGE] button to select the accompaniment volume page, the 3-digit-LED will display the accompaniment volume(A22).
3. Press [+] or [-] button to adjust the value.
Range:(0 to 32).

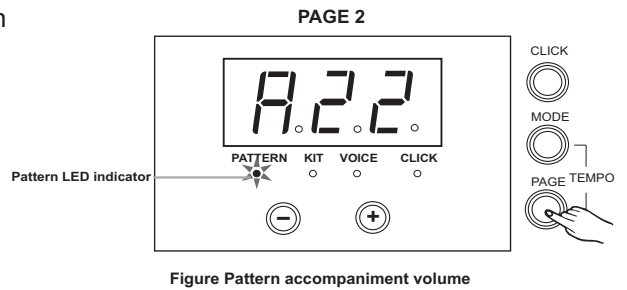

Adjust the drum volume

In pattern mode, pattern drum volume(0-032)

1. Press [MODE] button to select the pattern mode, the pattern LED indicator will be lighted up,
2. Press [PAGE] button to select the drum volume page, the 3-digit-LED will display the drum volume(d22).
3. Press [+] or [-] to adjust the value.
Range:(0 to 32)

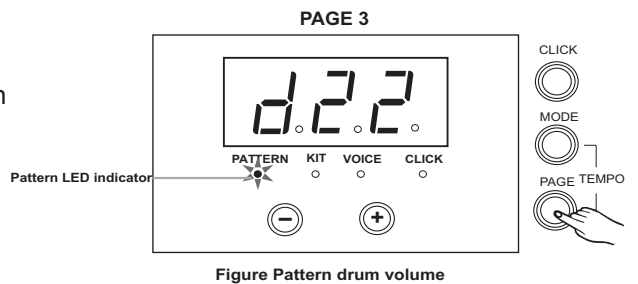

In kit mode, there are 3 pages:

1. kit number(001-010,default 1).
2. kit volume (0-32).
3. kit reverb:(on/off, default on).

Select a kit

In kit mode, kit number(001-010,default 1).

1. Press [MODE] button to select the kit mode, the kit LED indicator will be lighted up, the 3-digit-LED will display the kit number(001).
2. Press [+] or [-] to adjust the value.
Range:(001-010).

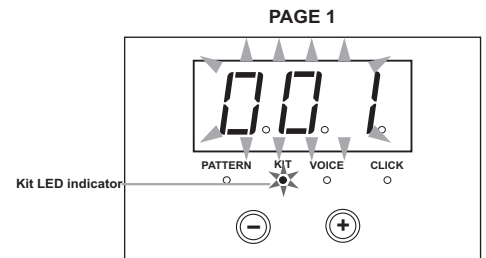

Figure Kit number

Adjust the kit volume

In kit mode, kit volume (0-32).

1. Press the [MODE] button to select the kit mode, the kit LED indicator will be lighted.
2. Press the [PAGE] button to select the kit volume page, the 3-digit-LED will display the kit volume(L30).
3. Press [+] or [-] to adjust the value (Automatic save).
Range:(0 to 32).

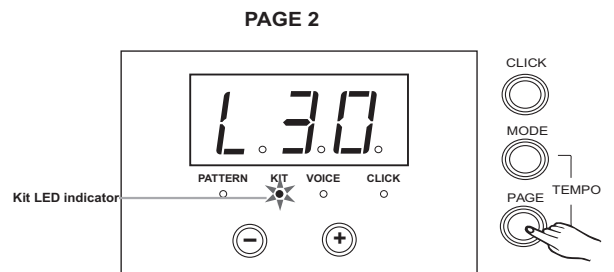
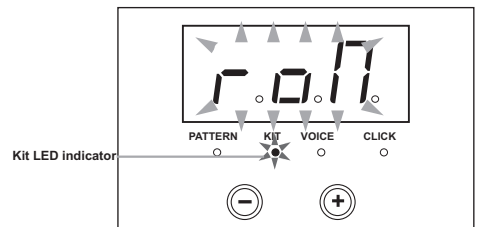

Figure Kit volume

Switch reverb on/off

1. Press [MODE] button to select the kit mode, the kit LED indicator will be lighted up.
2. Press the [PAGE] button to select the kit reverb page, reverb effect can be turn on or off by pressing button [+] or [-].



PAGE 3

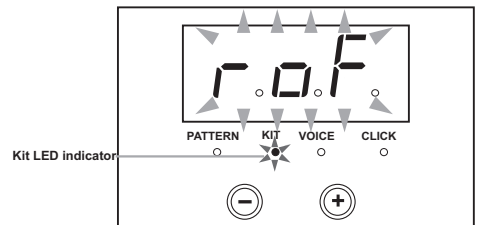

Voice

In voice mode, there are 3pages:

1. Voice number:(1-108).
2. Voice volume:(0-32).
3. Midi note:(0-99).

Select the voice

In voice mode, voice number:(1-108).

1. Press [MODE] button to select the voice mode, the voice LED indicator will be lighted up, strike a drum pad, the 3-digit-LED will display the voice number.
2. Press [+] or [-] to adjust the value(Automatic save).
Range:(001 to 108).

NOTE:

When you select a voice for hi-hit drum, you only can select the hi-hat group voices, from group 1-group 4(Automatic save), the display is:(H-I).

PAGE 1

Voice LED indicator

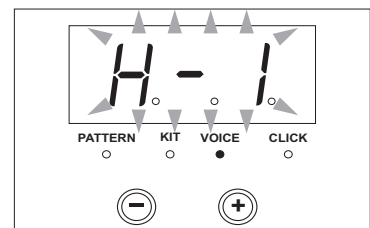
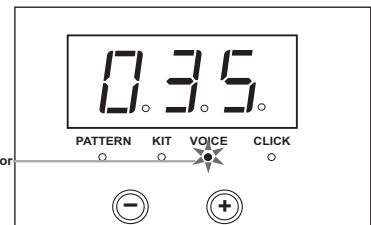

Adjust the voice volume

In voice mode, voice volume:(0-32).

1. Press [MODE] button to select the voice mode, the voice LED indicator will be lighted up.
2. Press [PAGE] button to select the voice volume page, strike a drum pad, the 3-digit-LED will display the voice volume(L30).
3. Press [+] or [-] to adjust the value(Automatic save).
Range:(0 to 32).

PAGE 2

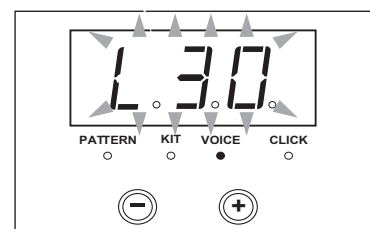

Adjust the midi note

In voice mode, midi note:(0-99).

1. Press [MODE] button to select the voice mode, the voice LED indicator will be lighted up.
2. Press [PAGE] button to select the midi note page, strike a drum pad, the 3-digit-LED will display the midi note (n48).
3. Press [+] or [-] to adjust the value(Automatic save).
Range:(0 to 99).



THE DEFAULT MIDI NOTE:

| NO. | NAME | NOTE |
|-----|-------------|------|
| 1 | CRASH1 | 49 |
| 2 | TOM 1 | 48 |
| 3 | TOM 2 | 45 |
| 4 | TOM 3 | 43 |
| 5 | RIDE | 51 |
| 6 | KICK | 36 |
| 7 | SNARE | 38 |
| 8 | HIHAT CLOSE | 42 |
| 9 | HIHAT OPEN | 46 |
| 10 | HIHAT PEDAL | 44 |

Tempo

The tempo range is 30-280

Adjust the tempo

1. Press both [MODE] and [PAGE] buttons, the 3-digit-LED will display the tempo page, it will temporarily display for 3 seconds.
2. Press [+] or [-] to adjust the value.

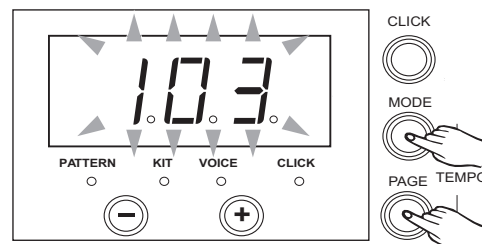

In click mode, there are 4 pages:

1. Time signature:(1/4-7/4,3/8,6/8).
2. Interval:(1/4,1/8,1/12,1/16,1/24,default 1/4).
3. Instrument:(1-5,default 1).
4. Click volume:(0-32).

Adjust the click time signature

In click mode, Time signature:(1/4-7/4,3/8,6/8).

1. Press [MODE] button select the click mode, the click LED indicator will be lighted up.
2. Press [PAGE] button select the click time signature page, the 3-digit-LED will display the click time signature(4-4).
3. Press [+] or [-] to adjust the value.
Range:(1/4-7/4 or 3/8 or 6/8).

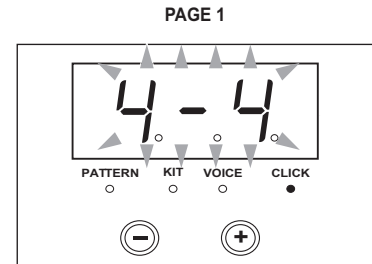

Note: The click time signature will follow the pattern, when pattern is playing, it can not be edit.

Adjust the click interval

In click mode, interval:(1/4,1/8,1/12,1/16,1/24,default 1/4).

1. Press [MODE] button to select the click mode, the click LED indicator will be lighted up.
2. Press [PAGE] button to select the click interval page, the 3-digit-LED will display the click interval(--4) .
3. Press the [+] or [-] button to adjust the value.
Range:(--4 to -24).

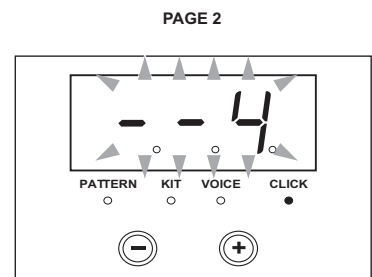

Adjust the click instrument

In click mode, instrument:(1-5,default 1).

1. Press [MODE] button to select the click mode, the click LED indicator will be lighted up.
2. Press [PAGE] button to select the click instrument page, the 3-digit-LED will display the click instrument(CL1).
3. Press [+] or [-] to adjust the value.
Range:(CL1 to CL5).

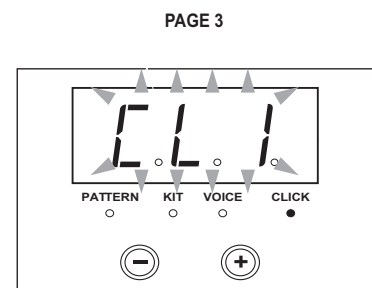

Adjust the click volume

In click mode, click volume:(0-32).

1. Press [MODE] button to select the click mode, the click LED indicator will be lighted up.
2. Press [PAGE] button to select the click volume page, the 3-digit-LED will display the click volume(L24).
3. Press [+] or [-] to adjust the value.
Range:(0 to 32)



Restore the factory preset

Restoring the factory preset can be implemented by following operations:

Turn on the power with both [+] and [-] unreleased.

This function will replace the current settings of following parameters by their default preset values:

Kit volume, voice number, voice volume and MIDI note.

Play the demo

1. Hold on the [CLICK] button 2 seconds to enter the demo and play the demo, the 3-digit-LED will display the demo "dE".
2. Press [START/STOP] button to stop the demo playing.

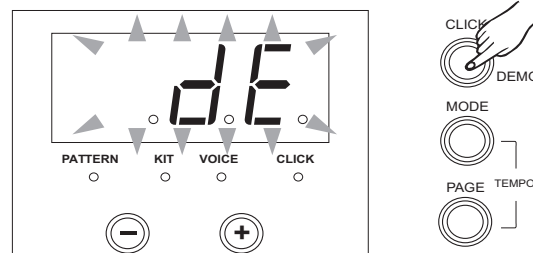

Play the pattern

1. Press [START/STOP] button play the pattern.
2. Press [START/STOP] button again to stop the pattern playing.

Play the click

1. Press the [CLICK] button to start the click, the click indicator will flash follow the beat.
2. Press the [CLICK] button again to stop the click.

Specifications

Drum Pad

4 drum pads , 3 cymbal pads , 1 hi-hat control pedal , 1 kick pedal

Preset Drum kits

10 preset kits

Drum Instrument

108

Preset Pattern

40

Controls

MIDI OUT, POWER SWITCH, USB, PHONES, START/STOP,PATTERN, KIT, VOICE, CLICK, MODE, PAGE, DEMO, TEMPO, VOLUME, + / -

Display

LED display

Connections

PHONES

AUX IN

OUTPUT (R & L/MONO)

MIDI OUT

USB

ON/OFF

Power Supply

AC adaptor (≡ 9V)

Preset Drum KIT list

No. Name

| | |
|-----|------------|
| 001 | Acoustic |
| 002 | Standard 1 |
| 003 | Rock |
| 004 | Standard 2 |
| 005 | Funk |
| 006 | Jazz |
| 007 | Brush |
| 008 | Electronic |
| 009 | 808 |
| 010 | House |

Drum Instrument List

No. Name

| | |
|-------------|-----------------|
| KICK | |
| 001 | Standard Kick 1 |
| 002 | Standard Kick 2 |
| 003 | Room Kick |
| 004 | Rock Kick 1 |
| 005 | Rock Kick 2 |
| 006 | Acoustic Kick |
| 007 | HipHop Kick |
| 008 | Funk Kick |
| 009 | Jazz Kick 1 |
| 010 | Jazz Kick 2 |
| 011 | Electronic Kick |
| 012 | 808 Kick |
| 013 | House Kick 1 |
| 014 | House Kick 2 |

| | |
|--------------|---------------------|
| SNARE | |
| 015 | Classic Snare 1 |
| 016 | Classic Snare Rim 1 |
| 017 | Classic Snare 2 |
| 018 | Classic Snare Rim 2 |
| 019 | Room Snare 1 |
| 020 | Room Snare 2 |
| 021 | Acoustic Snare |

No. Name

| | |
|-----|---------------------|
| 022 | Acoustic Snare Rim |
| 023 | Funk Band Snare |
| 024 | Funk Band Snare Rim |
| 025 | Camco Snare |
| 026 | Camco Snare Rim |
| 027 | Brush Snare |
| 028 | Brush Snare Rim |
| 029 | Electronic Snare 1 |
| 030 | Electronic Snare 2 |
| 031 | 808 Snare |
| 032 | House Snare 1 |
| 033 | House Snare 2 |

| | |
|------------|---------------|
| TOM | |
| 034 | Classic Tom 1 |
| 035 | Classic Tom 2 |
| 036 | Classic Tom 3 |
| 037 | Classic Tom 4 |
| 038 | Classic Tom 5 |
| 039 | Classic Tom 6 |
| 040 | Camco Tom 1 |
| 041 | Camco Tom 2 |
| 042 | Camco Tom 3 |

No. Name

| | |
|-----|------------------|
| 043 | Camco Tom 4 |
| 044 | Camco Tom 5 |
| 045 | Camco Tom 6 |
| 046 | 808 Tom 1 |
| 047 | 808 Tom 2 |
| 048 | 808 Tom 3 |
| 049 | 808 Tom 4 |
| 050 | 808 Tom 5 |
| 051 | 808 Tom 6 |
| 052 | Electronic Tom 1 |
| 053 | Electronic Tom 2 |
| 054 | Electronic Tom 3 |
| 055 | Electronic Tom 4 |
| 056 | Electronic Tom 5 |
| 057 | Electronic Tom 6 |

| | |
|-------------|-------------------|
| RIDE | |
| 058 | Classic Ride |
| 059 | Classic Ride Bell |
| 060 | Rock Ride |
| 061 | 808 Ride |

| | |
|--------------|------------------|
| CRASH | |
| 062 | Standard Crash 1 |

No. Name

| | |
|-----|------------------|
| 063 | Standard Crash 2 |
| 064 | Rock Crash |
| 065 | Splash 1 |
| 066 | Splash 2 |
| 067 | Brush Crash |
| 068 | 808 Crash |

| | |
|---------------|-------------------------|
| HI-HAT | |
| 069 | Standard Hi-hat Open |
| 070 | Jazz Hi-hat Open |
| 071 | Electronic Hi-hat Open |
| 072 | 808 Hi-hat Open |
| 073 | Standard Hi-hat Close |
| 074 | Jazz Hi-hat Close |
| 075 | Electronic Hi-hat Close |
| 076 | 808 Hi-hat Close |
| 077 | Standard Hi-hat Pad |
| 078 | Jazz Hi-hat Pad |
| 079 | Electronic Hi-hat Pad |
| 080 | 808 Hi-hat Pad |

| | |
|--------------------|------------|
| PERCUSSTION | |
| 081 | Bongo High |

No. Name

| | |
|-----|-------------------|
| 082 | Bongo Low |
| 083 | Mute Conga Hi-hat |
| 084 | Open Conga Hi-hat |
| 085 | Conga Low |
| 086 | Timbale High |
| 087 | Timale Low |
| 088 | Agogo High |
| 089 | Agogo Low |
| 090 | Cabasa |
| 091 | Maracas |
| 092 | Short Whistle |
| 093 | Long Whistle |
| 094 | Short Guiro |
| 095 | Long Guiro |
| 096 | Claves |
| 097 | Wood Block High |
| 098 | Wood Block Low |
| 099 | Mute Cuica |
| 100 | Open Cuica |
| 101 | Mute Triangle |
| 102 | Open Triangle |
| 103 | Shaker |
| 104 | Jingle Bell |
| 105 | Belltrees |
| 106 | Castanets |
| 107 | Mute Surdo |
| 108 | Open Surdo |

Preset Pattern List

No. Name

| | | | |
|-----|-------------------|-----|---|
| 001 | Fusion 1 | 103 | 1 |
| 002 | Electronic & Funk | 116 | 9 |
| 003 | Modern Pop | 136 | 1 |
| 004 | HipHop | 110 | 9 |
| 005 | Latin Jazz 1 | 130 | 7 |
| 006 | Funk 1 | 120 | 5 |
| 007 | Big Band 1 | 170 | 6 |
| 008 | Funk 2 | 112 | 1 |
| 009 | Pop Funk 1 | 112 | 1 |
| 010 | Fusion 2 | 112 | 1 |
| 011 | Funk 3 | 120 | 5 |
| 012 | Fusion 3 | 108 | 1 |
| 013 | Fusion 4 | 116 | 1 |
| 014 | Pop Funk 2 | 106 | 5 |
| 015 | R&B | 86 | 9 |
| 016 | Drum & Bass 1 | 168 | 9 |
| 017 | Break Beat | 108 | 5 |
| 018 | Dance | 130 | 9 |
| 019 | Drum & Bass 2 | 170 | 1 |
| 020 | Latin Dance | 126 | 5 |

Tempo Kit

No. Name

| | | | |
|------------------|---------------|-----|---|
| 021 | Swing | 172 | 6 |
| 022 | Latin Jazz 2 | 126 | 7 |
| 023 | Big Band 2 | 152 | 6 |
| 024 | 3/4 Jazz | 120 | 7 |
| 025 | Jazz | 150 | 7 |
| 026 | 6/8 Ballad | 96 | 3 |
| 027 | Pop Ballad | 80 | 3 |
| 028 | Pop Bossa | 120 | 2 |
| 029 | 16Beat Pop | 120 | 5 |
| 030 | Pop Shuffle | 86 | 5 |
| 031 | Samba | 236 | 1 |
| 032 | Mambo | 126 | 5 |
| 033 | Latin Rock | 136 | 1 |
| 034 | Latin Pop | 126 | 5 |
| 035 | Guitar Bossa | 84 | 5 |
| 036 | Country Blues | 128 | 3 |
| 037 | Rock | 100 | 1 |
| 038 | Reggae | 78 | 1 |
| 039 | 60's Rock | 120 | 2 |
| 040 | Blues | 96 | 2 |
| Demo Funk | | 100 | 1 |

Tempo Kit

GM Backing Instrument List

PIANO

- 1 Acoustic Grand Piano
- 2 Bright Acoustic Piano
- 3 Electric Grand Piano
- 4 Honky-Tonk Piano
- 5 E.Piano 1
- 6 E.Piano 2
- 7 Harpsichord
- 8 Clavi

MALLET

- 9 Celesta
- 10 Glockenspiel
- 11 Music Box
- 12 Vibraphone
- 13 Marimba
- 14 Xylophone
- 15 Tubular Bells
- 16 Dulcimer

ORGAN

- 17 Drawbar Organ
- 18 Percussive Organ
- 19 Rock Organ
- 20 Church Organ
- 21 Reed Organ
- 22 Accordion
- 23 Harmonica
- 24 Tango Accordion

GUITAR

- 25 Nylon Guitar
- 26 Steel Guitar
- 27 Jazz Guitar
- 28 Clean Guitar
- 29 Muted Guitar
- 30 Overdriven Guitar
- 31 Distortion Guitar
- 32 Guitar Harmonics

BASS

- 33 Acoustic Bass
- 34 Finger Bass
- 35 Pick Bass
- 36 Fretless Bass
- 37 Slap Bass 1
- 38 Slap Bass 2
- 39 Synth Bass 1
- 40 Synth Bass 2

STRINGS

- 41 Violin
- 42 Viola
- 43 Cello
- 44 Contrabass
- 45 Tremolo Strings
- 46 Pizzicato Strings
- 47 Orchestral Harp
- 48 Timpani

STRINGS ENSEMBLE

- 49 Strings Ensemble 1
- 50 Strings Ensemble 2
- 51 Synth Strings 1
- 52 Synth Strings 2
- 53 Choir Aahs
- 54 Voice Oohs
- 55 Synth Voice
- 56 Orchestra Hit

BRASS

- 57 Trumpet
- 58 Trombone
- 59 Tuba
- 60 Muted Trumpet
- 61 French Horn
- 62 Brass Section
- 63 Synth Brass 1
- 64 Synth Brass 2

REED

- 65 Soprano Sax
- 66 Alto Sax
- 67 Tenor Sax
- 68 Baritone Sax
- 69 Oboe
- 70 English Horn
- 71 Bassoon
- 72 Clarinet

PIPE

- 73 Piccolo
- 74 Flute
- 75 Recorder
- 76 Pan Flute
- 77 Blown Bottle
- 78 Shakuhachi
- 79 Whistle
- 80 Ocarina

LEAD

- 81 Lead1 (square)
- 82 Lead2 (sawtooth)
- 83 Lead3 (calliope)
- 84 Lead4 (chiff)
- 85 Lead5 (charang)
- 86 Lead6 (voice)
- 87 Lead7 (fifths)
- 88 Lead8 (bass & Lead)

PAD

- 89 Pad1 (newage)
- 90 Pad2 (warm)
- 91 Pad3 (Polysynth)
- 92 Pad4 (choir)
- 93 Pad5 (bowed)
- 94 Pad6(metallic)
- 95 Pad7 (halo)
- 96 Pad8 (sweep)

EFFECTS

- 97 FX1 (rain)
- 98 FX2 (soundtrack)
- 99 FX3 (crystal)
- 100 FX4 (atmosphere)
- 101 FX5 (brightness)
- 102 FX6 (goblins)
- 103 FX7 (echoes)
- 104 FX8 (sci-fi)

ETHNIC

- 105 Sitar
- 106 Banjo
- 107 Shamisen
- 108 Koto
- 109 Kalimba
- 110 Bagpipe
- 111 Fiddle
- 112 Shanai

PERCUSSIVE

- 113 Tinkle Bell
- 114 Agogo
- 115 Steel Drums
- 116 Wood Block
- 117 Taiko Drum
- 118 Melodic Tom
- 119 Synth Drum
- 120 Reverse Cymbal

SOUND EFFECTS

- 121 Guitar Fret Noise
- 122 Breath Noise
- 123 Seashore
- 124 Bird Tweet
- 125 Telephone Ring
- 126 Helicopter
- 127 Applause
- 128 Gunshot

GM Drum Kit List

| NET NO. | Standard 1 (bank 0) | Standard 2 (bank 4) | Room (bank 8) | Rock (bank 16) | Funk (bank 17) |
|---------|-------------------------|-------------------------|--------------------|--------------------|-------------------|
| 27-D#1 | High Q | <- | <- | <- | <- |
| 28-E1 | Slap | <- | <- | <- | <- |
| 29-F1 | Scratch Push | <- | <- | <- | <- |
| 30-F#1 | Scratch Pull | <- | <- | <- | <- |
| 31-G1 | Sticks | <- | <- | <- | <- |
| 32-G#1 | Square Click | <- | <- | <- | <- |
| 33-A1 | Metronome Click | <- | <- | <- | <- |
| 34-A#1 | Metronome Bell | <- | <- | <- | <- |
| 35-B1 | Acoustic Bass Drum | <- | Room Bass Drum 1 | Rock Bass Drum 1 | Funk Bass Drum 1 |
| 36-C2 | Standard 1 Bass Drum | Standard 2 Bass Drum | Room Bass Drum 2 | Rock Bass Drum 2 | Funk Bass Drum 2 |
| 37-C#2 | Side Stick | <- | <- | <- | <- |
| 38-D2 | Standard 1 Snare | Standard 2 Snare | Room Snare | Rock Snare | Funk Snare |
| 39-D#2 | Hand Clap | <- | <- | <- | <- |
| 40-E2 | Standard 1 Snare Rim | Standard 2 Snare Rim | Room Snare Rim | Rock Snare Rim | Funk Snare Rim |
| 41-F2 | Standard 1 Tom 6 | Standard 2 Tom 6 | Room Tom 6 | Rock Tom 6 | Funk Tom 6 |
| 42-F#2 | Standard 1 Hi-hat Close | Standard 2 Hi-hat Close | Room Hi-hat Close | Rock Hi-hat Close | Funk Hi-hat Close |
| 43-G2 | Standard 1 Tom 5 | Standard 2 Tom 5 | Room Tom 5 | Rock Tom 5 | Funk Tom 5 |
| 44-G#2 | Standard 1 Hi-hat Pedal | Standard 2 Hi-hat Pedal | Room Hi-hat Pedal | Rock Hi-hat Pedal | Funk Hi-hat Pedal |
| 45-A2 | Standard 1 Tom 4 | Standard 2 Tom 4 | Room Tom 4 | Rock Tom 4 | Funk Tom 4 |
| 46-A#2 | Standard 1 Hi-hat Open | Standard 2 Hi-hat Open | Room Hi-hat Open | Rock Hi-hat Open | Funk Hi-hat Open |
| 47-B2 | Standard 1 Tom 3 | Standard 2 Tom 3 | Room Tom 3 | Rock Tom 3 | Funk Tom 3 |
| 48-C3 | Standard 1 Tom 2 | Standard 2 Tom 2 | Room Tom 2 | Rock Tom 2 | Funk Tom 2 |
| 49-C#3 | Standard 1 Crash 1 | Standard 2 Crash 1 | Room Crash 1 | Rock Crash 1 | Funk Crash 1 |
| 50-D3 | Standard 1 Tom 1 | Standard 2 Tom 1 | Room Tom 1 | Rock Tom 1 | Funk Tom 1 |
| 51-D#3 | Standard 1 Ride | Standard 2 Ride | Room Ride | Rock Ride | Funk Ride |
| 52-E3 | Chinese Cymbal 1 | <- | <- | <- | <- |
| 53-F3 | Ride Bell | <- | Room Ride Bell | Rock Ride Bell | <- |
| 54-F#3 | Tambourine | <- | <- | <- | <- |
| 55-G3 | Splash Cymbal | <- | Room Splash Cymbal | Rock Splash Cymbal | <- |
| 56-G#3 | Standard 1 Cowbell | Standard 2 Cowbell | Room Cowbell | Rock Cowbell | <- |
| 57-A3 | Standard 1 Crash 2 | Standard 2 Crash 2 | Room Crash 2 | Rock Crash 2 | Funk Crash 2 |
| 58-A#3 | Vibra-slap | <- | <- | <- | <- |
| 59-B3 | Ride Cymbal | <- | <- | <- | <- |
| 60-C4 | Hi Bongo | <- | <- | <- | <- |
| 61-C#4 | Low Bongo | <- | <- | <- | <- |
| 62-D4 | Mute Hi Conga | <- | <- | <- | <- |
| 63-D#4 | Open Hi Conga | <- | <- | <- | <- |
| 64-E4 | Low Conga | <- | <- | <- | <- |
| 65-F4 | High Timbale | <- | <- | <- | <- |
| 66-F#4 | Low Timbale | <- | <- | <- | <- |
| 67-G4 | High Agogo | <- | <- | <- | <- |
| 68-G#4 | Low Agogo | <- | <- | <- | <- |
| 69-A4 | Cabasa | <- | <- | <- | <- |
| 70-A#4 | Maracas | <- | <- | <- | <- |
| 71-B4 | Short Whistle | <- | <- | <- | <- |
| 72-C5 | Long Whistle | <- | <- | <- | <- |
| 73-C#5 | Short Guiro | <- | <- | <- | <- |
| 74-D5 | Long Guiro | <- | <- | <- | <- |
| 75-D#5 | Claves | <- | <- | <- | <- |
| 76-E5 | Hi Wood Block | <- | <- | <- | <- |
| 77-F5 | Low Wood Block | <- | <- | <- | <- |
| 78-F#5 | Mute Cuica | <- | <- | <- | <- |
| 79-G5 | Open Cuica | <- | <- | <- | <- |
| 80-G#5 | Mute Triangle | <- | <- | <- | <- |
| 81-A5 | Open Triangle | <- | <- | <- | <- |
| 82-A#5 | Shaker | <- | <- | <- | <- |
| 83-B5 | Jingle Bell | <- | <- | <- | <- |
| 84-C6 | Bell Tree | <- | <- | <- | <- |
| 85-C#6 | Castanets | <- | <- | <- | <- |
| 86-D6 | Mute Surdo | <- | <- | <- | <- |
| 87-D#6 | Open Surdo | <- | <- | <- | <- |

GM Drum Kit List

| NET NO. | Electronic (bank 24) | 808 (bank 25) | House (bank 28) | Jazz (bank 32) | Brush (bank 40) |
|---------|-------------------------|-------------------|--------------------|-------------------|-------------------|
| 27-D#1 | <- | <- | <- | <- | <- |
| 28-E1 | <- | <- | <- | <- | <- |
| 29-F1 | <- | <- | <- | <- | <- |
| 30-F#1 | <- | <- | <- | <- | <- |
| 31-G1 | <- | <- | <- | <- | <- |
| 32-G#1 | <- | <- | <- | <- | <- |
| 33-A1 | <- | <- | <- | <- | <- |
| 34-A#1 | <- | <- | <- | <- | <- |
| 35-B1 | Electronic Bass Drum 1 | 808 Bass Drum 1 | House Bass Drum 1 | Jazz Bass Drum 1 | Brush Bass Drum 1 |
| 36-C2 | Electronic Bass Drum 2 | 808 Bass Drum 2 | House Bass Drum 2 | Jazz Bass Drum 2 | Brush Bass Drum 2 |
| 37-C#2 | <- | <- | <- | <- | <- |
| 38-D2 | Electronic Snare | 808 Snare | House Snare | Jazz Snare | Brush Snare |
| 39-D#2 | <- | <- | House Hand Clap | <- | <- |
| 40-E2 | Electronic Snare Rim | 808 Snare Rim | House Snare Rim | Jazz Snare Rim | Brush Snare Rim |
| 41-F2 | Electronic Tom 6 | 808 Tom 6 | House Tom 6 | Jazz Tom 6 | Brush Tom 6 |
| 42-F#2 | Electronic Hi-hat Close | 808 Hi-hat Close | House Hi-hat Close | Jazz Hi-hat Close | <- |
| 43-G2 | Electronic Tom 5 | 808 Tom 5 | House Tom 5 | Jazz Tom 5 | Brush Tom 5 |
| 44-G#2 | Electronic Hi-hat Pedal | 808 Hi-hat Pedal | House Hi-hat Pedal | Jazz Hi-hat Pedal | <- |
| 45-A2 | Electronic Tom 4 | 808 Tom 4 | House Tom 4 | Jazz Tom 4 | Brush Tom 4 |
| 46-A#2 | Electronic Hi-hat Open | 808 Hi-hat Open | House Hi-hat Open | Jazz Hi-hat Open | <- |
| 47-B2 | Electronic Tom 3 | 808 Tom 3 | House Tom 3 | Jazz Tom 3 | Brush Tom 3 |
| 48-C3 | Electronic Tom 2 | 808 Tom 2 | House Tom 2 | Jazz Tom 2 | Brush Tom 2 |
| 49-C#3 | <- | 808 Crash 1 | <- | <- | Brush Crash 1 |
| 50-D3 | Electronic Tom 1 | 808 Tom 1 | House Tom 1 | Jazz Tom 1 | Brush Tom 1 |
| 51-D#3 | <- | <- | <- | Jazz Ride | Brush Ride |
| 52-E3 | <- | <- | <- | <- | <- |
| 53-F3 | <- | <- | <- | <- | <- |
| 54-F#3 | <- | <- | <- | <- | <- |
| 55-G3 | <- | <- | <- | <- | <- |
| 56-G#3 | <- | <- | <- | <- | <- |
| 57-A3 | <- | 808 Crash 2 | <- | ChineseCymbal 2 | Brush Crash 2 |
| 58-A#3 | <- | <- | <- | <- | <- |
| 59-B3 | <- | <- | <- | <- | <- |
| 60-C4 | <- | <- | <- | <- | <- |
| 61-C#4 | <- | <- | <- | <- | <- |
| 62-D4 | <- | 808 Mute Hi Conga | <- | <- | <- |
| 63-D#4 | <- | 808 Open Hi Conga | <- | <- | <- |
| 64-E4 | <- | 808 Low Conga | <- | <- | <- |
| 65-F4 | <- | <- | <- | <- | <- |
| 66-F#4 | <- | <- | <- | <- | <- |
| 67-G4 | <- | <- | <- | <- | <- |
| 68-G#4 | <- | <- | <- | <- | <- |
| 69-A4 | <- | <- | <- | <- | <- |
| 70-A#4 | <- | 808 Maracas | <- | <- | <- |
| 71-B4 | <- | <- | <- | <- | <- |
| 72-C5 | <- | <- | <- | <- | <- |
| 73-C#5 | <- | <- | <- | <- | <- |
| 74-D5 | <- | <- | <- | <- | <- |
| 75-D#5 | <- | 808 Claves | <- | <- | <- |
| 76-E5 | <- | <- | <- | <- | <- |
| 77-F5 | <- | <- | <- | <- | <- |
| 78-F#5 | <- | <- | <- | <- | <- |
| 79-G5 | <- | <- | <- | <- | <- |
| 80-G#5 | <- | <- | <- | <- | <- |
| 81-A5 | <- | <- | <- | <- | <- |
| 82-A#5 | <- | <- | <- | <- | <- |
| 83-B5 | <- | <- | <- | <- | <- |
| 84-C6 | <- | <- | <- | <- | <- |
| 85-C#6 | <- | <- | <- | <- | <- |
| 86-D6 | <- | <- | <- | <- | <- |
| 87-D#6 | <- | <- | <- | <- | <- |

MIDI Implementation Chart

| | Function... | Transmitted | Recognized | Remarks |
|------------------|-----------------|----------------|----------------|----------------------|
| Basic Channel | Default | 10 ch | 1-16 | |
| | Changed | X | X | |
| | Default | X | X | |
| Mode | Messages | X | X | |
| | Altered | ***** | ***** | |
| Note Number: | True voice | 0-127 ***** | 0-127 0-127 | |
| Velocity | Note on | O 99H, V=1-127 | 0-127 | |
| | Note off | O (9 9H. V=0) | 0-127 | |
| After Touch | Key's | X | X | |
| | Channel's | X | X | |
| Pitch Bend | | X | O | |
| Control Change | 0 | X | O | Bank Select |
| | 1 | X | O | Modulation |
| | 5 | X | O | Portamento Time |
| | 6 | X | O | Data Entry |
| | 7 | X | O | Volume |
| | 10 | X | O | Pan |
| | 11 | X | O | Expression |
| | 64 | X | O | Sustain Pedal |
| | 65 | X | O | Portamento ON/OFF |
| | 66 | X | O | Sostenuto Pedal |
| | 67 | X | O | Soft Pedal |
| | 80 | X | O | Reverb Program |
| | 81 | X | O | Chorus Program |
| | 91 | X | O | Reverb Level |
| | 93 | X | O | Chorus Level |
| | 120 | X | O | All Sound OFF |
| | 121 | X | O | Reset All Controller |
| | 123 | X | O | All Notes OFF |
| Program Change | | X | O | |
| System Exclusive | | X | O | |
| System Common | : Song Position | X | X | |
| | : Song Select | X | X | |
| | : Tune | X | X | |
| System Real Time | : Clock | O | X | START \ STOP |
| | : Commands | O | X | |
| Aux Messages | : Local ON/OFF | X | X | |
| | : All Notes OFF | X | X | |
| | : Active Sense | O | X | |
| | : Reset | X | X | |

O : YES

X : NO

