



**TRITHOR®**  
TERMITE PROTECTION

**2023**

# TECHNICAL MANUAL

ENSYSTEX AUSTRALASIA PTY LTD  
Unit 3, The Junction Estate  
4-6 Junction Street  
AUBURN NSW 2144  
13 35 36  
info@trithor.com.au



**Table of Contents**

**Introduction to TRITHOR ..... 4**

*Flexible*..... 4

*Long Lasting - Environmentally Sound* ..... 4

*Tough*..... 4

*Designed for the Harshest Conditions* ..... 4

*Health and Safety* ..... 4

*Eco specified* ..... 4

*CodeMark Certified* ..... 5

*Benefits*..... 5

*Compliance*..... 6

**TRITHOR Systems..... 7**

*FULL UNDERSLAB INSTALLATIONS* ..... 7

*PERIMETER INSTALLATIONSS* ..... 7

**Approved Installers ..... 7**

**Full Underslab Installation of TRITHOR Termite Protection ..... 8**

*Builder’s Responsibility*..... 9

*Pipe/ Service Penetrations*..... 9

*Installers’ Step by Step Guide* ..... 9

**Perimeter Installations of TRITHOR Termite Protection ..... 10**

*Limitations*..... 10

*Builder’s Responsibility*..... 10

*Installation Procedures – Cavity Wall Perimeters* ..... 10

*Inspection Zones*..... 15

*Step-downs*..... 15

*Rendered Walls*..... 25

*Corner Details*..... 27

*Joining TRITHOR* ..... 28

*Pipe/ Service Penetrations*..... 28

*Retaining Walls*..... 30

*Construction Joints* ..... 32

*Access Ramps* ..... 32

*Timber Flooring* ..... 33

*Doors and Windows* ..... 33

*Suspended Floors*..... 33

*Demountable Mining Houses* ..... 35

*Other Systems*..... 36

*Isolated Pier/ Column* ..... 42

**Essential Equipment..... 46**

**Paperwork/ Warranty Process..... 46**

® TRITHOR is a Registered Trademark of Ensysstex Inc. used under licence by Ensysstex Australasia Pty Ltd

This Technical Manual details many methods by which TRITHOR can be installed. However, it is NOT an exhaustive list of methods of installation. Other method of installation may be employed in different building design situations.

The most important perspective with respect to the successful installation of TRITHOR is to ensure it is installed in accord with the principles of the Australian Standard AS 3660 *Termite management Part 1: New building work* and it's APVMA Approved Label.

Other applications are approved to deal with more complex building designs, and Ensystem reserves the right to continually update the methods of installation.

## Introduction to TRITHOR

TRITHOR consists of an inner core layer impregnated with deltamethrin and laminated top and bottom with a rugged plastic membrane. This complex entrapment process ensures that the deltamethrin remains contained within the inner core. This ensures it is non-hazardous to anyone handling the product or who comes into contact with it.

The termite control agent in TRITHOR, deltamethrin, is an insecticide that is modelled on the natural pyrethrins produced by the chrysanthemum daisy, nature's own cure for insect problems. Consequently, it is low in toxicity to warm-blooded animals, though deadly to termites and other insects. Deltamethrin both kills and strongly repels termites. Deltamethrin is a registered termiticide with the Australian Pesticides & Veterinary Medicines Authority (APVMA).

The inner core of TRITHOR adds to the durability and effectiveness of the system. TRITHOR has undergone extensive independent testing and evaluation in Australia and overseas. The inner core, in addition to holding the deltamethrin so it remains ever ready to kill and deter termites, is structured to prevent termite penetration.

The upper blue layer is thicker and ensures that TRITHOR provides an additional benefit by serving as a moisture vapour barrier or damp-proof course.

The bottom yellow layer protects the deltamethrin and prevents leaching into the environment, thereby ensuring that it remains locked away from soil organisms and soil moisture.

The polymers used in the formation of TRITHOR are resistant to termites and, since TRITHOR also acts as a moisture barrier, it further reduces the attractiveness of a property to termites.

### Flexible

TRITHOR is a flexible system that may be installed in many difficult and complicated situations including multiple penetrations, step-downs, etc. TRITHOR can be moulded around unusual building designs and is easily cut and joined, ensuring total protection at all times. It is quickly installed and has no sharp edges to affect other tradespeople.

### Long Lasting - Environmentally Sound

The deltamethrin remains safely locked up within the inner core, so it cannot enter the environment.

### Tough

TRITHOR is exceptionally tough. A sharp cutting blade is required to cut TRITHOR. Blunt objects, workmen's boots, etc. have no chance of penetrating TRITHOR. If a hole or tear is accidentally produced it is easily repaired.

### Designed for the Harshest Conditions

TRITHOR was designed for the harshest conditions and has been tested in Australia and SE Asia to ensure protection against the voracious termites native to these regions.

### Health and Safety

TRITHOR poses no risk to the homeowner, construction workers or the environment. It is ideal for use in sensitive or allergy-free environments.

### Eco specified

TRITHOR has been verified as meeting the GreenTag Sustainability Rate A and Platinum Health Rate.

Global GreenTag is a world leading, scientifically advanced, third-party green product certification, declaration & verification assessment service. Global GreenTag certified products pass the world's toughest standards for health, eco-performance, safety & ethics.

They are recognised & trusted in Australia, USA, South Africa, SE Asia and over 70 other countries. Every product is independently fitness tested under leading certification

programs that use the world’s best scientific methods. Global ‘Verified Product Standard’.

Global GreenTag® GreenRate certification enables products to be allocated Level A, B, or C, shedding light on the products durability, design, product stewardship, energy & water consumption, VOC emission, and corporate social responsibility (CSR) among other things.

The Product Health Declaration (PHD) HealthRATE™ ratings are a unique “Healthiness in Use” assessment that provides BronzeHEALTH™, SilverHEALTH™, GoldHEALTH™ or PlatinumHEALTH™ rating Tags relevant to consumers or end users as they address the healthiness of the product as it is installed in the final building.

These two qualifications are recognised worldwide and allow up to 100% of the available ‘green credit points’ to be accrued in all the major green and sustainability rating schemes including the International WELL Building Standard, LEED program (Leadership in Energy and Environmental Design), EarthCheck and BREEAM.

In Australia, the Green Building Council of Australia’s Green Star program is an internationally recognised rating system setting the standard for healthy, resilient, positive buildings and places, developed for the Australian environment.

These green points allow architects and builders to deliver cost effective and sustainable projects to their clients, who in turn benefit in a myriad of ways including creation of social capital, financial rewards (via tax benefits, etc.) and delivering health and well-being benefits to those who live and work in these buildings.

## CodeMark Certified

TRITHOR Termite Protection holds a CodeMark® Certificate of Conformity, relating to the National Construction Code, confirming compliance with relevant clauses of the Building Code of Australia (BCA). See the CodeMark Certificate of Compliance for further details.

Independent trials, conducted in accordance with the requirements of AS 3660 (2014) *Termite management Part 3 Assessment criteria for termite management systems* and other tests show that TRITHOR will provide effective termite protection in excess of 50 years, even in tropical situations.



## Benefits

**Easier to install and work with** due to slimmer and more compacted profile, making it less obtrusive in modern construction designs.

**Tough and rugged** will not tear easily.

**Flexible** suits all modern construction scenarios.

**Safer handling** is provided since TRITHOR features *Thermo-compression Technology™* which heat seals the product to prevent escape of the deltamethrin.

**Proven to last for fifty years or more** ensuring long-term protection of buildings.

**Better grout and mortar adhesion** during construction due to embossed upper surface.

**Superior performance** through the use of deltamethrin to provide active termite protection. Deltamethrin displays unequalled insecticidal efficacy and repellency and is three times more insecticidally potent than bifenthrin<sup>1</sup>, used in other systems.

<sup>1</sup> Chow-Yang Lee, Han-Heng Yap and Ngo-Long Chong; Vector Control Research Unit. School of Biological Sciences, Universiti Sains, Malaysia (1996).

**CodeMark Certified** through the Australian Building Codes Boards (ABCB) ensuring compliance with the National Construction Code (NCC) and Building Code of Australia (BCA), ensuring compulsory acceptance by certifiers.



**Proven to work** - more than 100,000 homes and buildings protected in Australia, and the number grows daily! TRITHOR is protecting buildings in Australia, the Middle East, SE Asia, and Europe.

**Environmentally responsible** as recognised by its *GreenTag Approvals* (see above) and Very Good Rating as a *Singapore Green Building Product*, the highest rating of any termite protection system.



**Compliant** for installing in association with NOVITHOR™ Termite Protection products.

**Warranty** protects builder and property owner and is upgradeable to protect against termites bridging the TRITHOR system. *Conditions apply.*

## Compliance

TRITHOR Termite Protection is approved as an alternative solution in accord with the Building Code of Australia (BCA). The Assessment Method is that independent scientific evidence has been produced to prove that TRITHOR Termite Protection meets the Performance Requirements and/or the Deemed-to-Satisfy Provisions of the Australian Standards *AS 3600 Series - Termite management*.

Evidence of this is contained within reports provided to the **Australian Pesticides & Veterinary Medicines Authority**, the **University of New South Wales's New South Global Consulting** who have provided an Independent Building Appraisal, and through the Australian Building Codes Board **CodeMark Accreditation**.

These evaluations included documentary evidence produced by CSIRO Entomology. These reports prove conclusively that TRITHOR Termite Protection meets, the requirements of:

*AS 3660.1 Termite Management - New building work;*

*AS 3660.3 Termite Management - Assessment criteria for termite management systems;*

*AS/NZS 4347 - Damp-proof courses & flashings;*

*AS 2870 Residential slabs and footings;*

*AS 3600 Concrete structures.*

Independent trials conducted in accordance with the requirements of the Australian Standard AS 3660.3 (2014) *Termite management Part 3*; and other tests show that TRITHOR should remain as an effective termite measure for 50 years.

TRITHOR Termite Protection meets the performance criteria of section 1 Clause 1.3 of *AS 3660 Termite management Part 1, (2014) New building work* in accordance with *AS 3660 Termite management Part 3 (2014) Assessment criteria for termite management systems*.

TRITHOR Termite Protection also meets the performance requirements BP1.1 (b)(xv), P2.1.1 (b)(xv), and QLD P2.1.3, NCC 2019 Amendment 1 Termite Actions.

## TRITHOR Systems

### FULL UNDERSLAB INSTALLATIONS

This is a complete under-slab treatment providing protection from both termites and moisture. The TRITHOR is installed on top of the bedding sand before the steel reinforcing mesh is laid. All pipes and penetrations are individually protected by TRITHOR as part of this treatment. The concrete is then poured on top of the TRITHOR.

When installed as a complete under-slab system, TRITHOR provides a stand-alone total termite defence system for the property. This means that termites are less likely to stay in the area, significantly reducing the potential for termite problems.

This should be your first choice in areas of high termite risk.

For this method of installation, TRITHOR is supplied in 1500 mm wide sheets which must be overlapped by 200 mm and sealed before being taped with a quality tape. This holds the TRITHOR firmly in place until the concrete pour.

Termites can't penetrate these sealed joints since TRITHOR is repellent to termites. At the joints, the repellence is doubled due to the double layer of TRITHOR.

This method of install provides both termite protection as well as the required Moisture Vapour Membrane.

### PERIMETER INSTALLATIONSS

TRITHOR Termite Protection is a flexible termite protection system which can be used as part of a complete termite management system in association with other approved systems. This is the most common manner of use.

It is particularly used in association with a concrete slab, poured and cured in accord with the requirements of AS 2870: *Residential slabs and footings* and AS 3600: *Concrete structures*.

The slab in this case forms part of the termite protection system with TRITHOR Termite Protection protecting the high-risk termite penetration areas. It is applied in a range of widths (strips) to suit the particular building design.

It is also used for the protection of bearer and joist constructions and piers. Annual Inspections

All termite management systems require at least an annual inspection by a professional timber pest inspector, in accord with the requirements of the Australian Standard Series AS 3660 *Termite management*. These inspections are integral to good termite management.

### Approved Installers

TRITHOR Termite Protection may only be installed by TRITHOR Approved Installers who have been trained by Ensysyex to help ensure that installations are done correctly and that systems comply with the requirements of this Manual, the CodeMark program, and the Australian Standard Series AS 3600 *Termite management*.

TRITHOR Approved Installers must demonstrate their understanding of, and compliance with, the procedures and requirements of this Technical Manual. Any breach of, or deviation from, the required procedures may result in the termination of their Approval.

Only appropriately trained and licensed pest management professionals can become as TRITHOR Approved Installers. The TRITHOR Approved Installer must nominate trained installers who will be operating under their Licence.

Licences may be cancelled, and supply stopped to any company that acts fraudulently or demonstrates consistently poor-quality workmanship.

## Full Underslab Installation of TRITHOR Termite Protection

When installed as a full under slab installation, TRITHOR provides both termite protection and a moisture membrane.

Installation is simple. Installation uses 1500 mm wide TRITHOR sheets which are laid prior to the slab in the exact same fashion as if laying a moisture membrane. The blue layer must be

placed uppermost. The sheets must be overlapped by 200 mm, and taped with a quality cloth tape, see Essential Equipment.

TRITHOR Termite Protection is always installed in accordance with the instructions and diagrams contained in this Manual and the requirements of the Australian Standard AS 3660 *Termite management Part 1: New building work*.

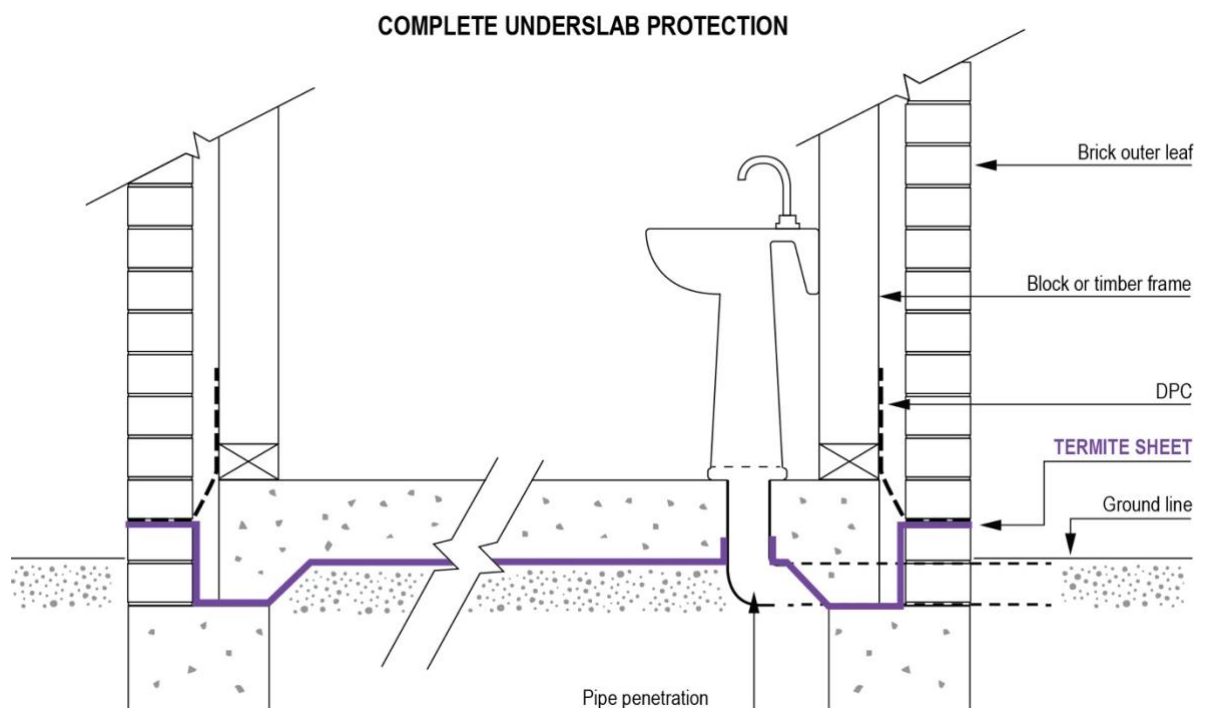



It is the responsibility of the TRITHOR Approved Installer to liaise with the Builder and ensure that the installation procedures are correctly performed so that the completed install can be certified by the TRITHOR Approved Installer to comply with the Ensystex Warranty Program.

### Builder's Responsibility

The builder must ensure that:

1. the under-slab soil substrate is levelled;
2. all service pipe penetrations are installed in their final position;
3. they are aware of the placement requirements for TRITHOR Termite Protection;
4. once laid, TRITHOR Termite Protection will not be moved without consulting with the TRITHOR Approved Installer; and
5. they inform the TRITHOR Approved Installer of any damage to, disturbance of, or misalignment of, the TRITHOR Termite Protection prior to the pouring of the concrete slab.

### Pipe/ Service Penetrations

Pipe penetrations are protected with TRITHOR Collars. See below.

### Installers' Step by Step Guide

1. Ensure the site has been levelled and all pipe penetrations are installed in their final positions.
2. If the tops of the service pipes to be protected are sealed with tape, the tape must be removed prior to installing, and then replaced on completion. (If, as often occurs in Queensland, the service pipes have lagging, the lagging must be above the TRITHOR Collar.)
3. TRITHOR Termite Protection is laid out in accord with the diagrams in this Manual and as per the normal requirements for a moisture membrane.
4. **Take great care to ensure that the system formed by the TRITHOR Termite Protection is complete and continuous.**
5. Care should be taken to ensure that the system is not affected by formwork pegs.
6. Many slabs are designed with internal structural beams as part of the concrete footing. When TRITHOR is laid under these beams, more material is required than the original site footprint. Where these beams are deeper than 150 mm, there is no requirement to lay TRITHOR. These thickened beams have extra reinforcing and are considered a termite system by the Australian Standard. (Since they still require protection against moisture with a normal moisture membrane, we recommend TRITHOR is still used.) This applies to both internal and external beams.
7. Refer also to the Australian Standard *AS 3660 Termite management Part 1: New building work*.
8. Give the Builder a copy of this Technical Manual and advise him of his obligations.

#### PIPE PENETRATION STEP 5 - CROSS-SECTION AFTER SLAB HAS BEEN LAID

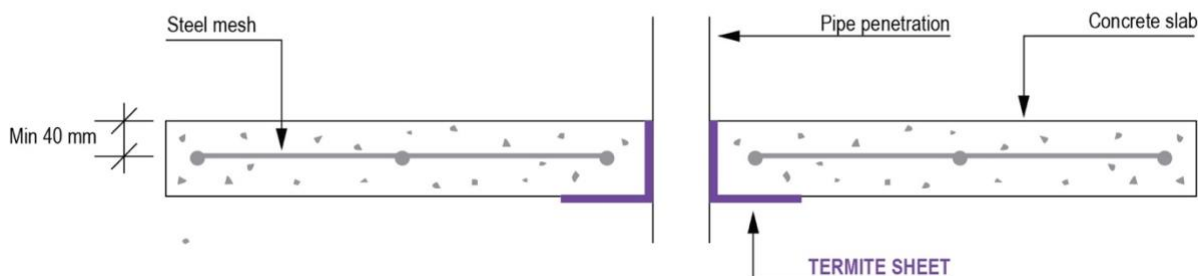

## Perimeter Installations of TRITHOR Termite Protection

TRITHOR Termite Protection uses strips of TRITHOR (75 mm - 1500 mm wide) in association with a concrete slab poured and cured in accord with the requirements of AS 2870: *Residential slabs and footings* and AS 3600: *Concrete structures*. The slab in this case forms part of the termite protection system with the TRITHOR Termite Protection protecting the possible termite penetration areas.

TRITHOR Termite Protection should be installed in accordance with the instructions contained in this Manual and the Australian Standard AS 3660 *Termite management Part 1: New building work*.

When installed in accordance with this Manual, TRITHOR Termite Protection should provide protection against the entry of subterranean termites provided all other aspects of the total system are approved and correctly installed.

An essential aspect of installation is to recognise that it will be the structural elements, that are placed after the TRITHOR system, that hold the system in place.

Before installing TRITHOR, always clean off all excess mortar from areas that TRITHOR will be placed over.

When joining TRITHOR Strips, overlap them by 50 - 75 mm and optionally seal with TRITHOR Adhesive or a quality Cloth Tape.

### Limitations

Where the concrete slab forms part of the termite protection system, it must be constructed in accordance with AS 2870 and/ or AS 3600.

It is the responsibility of the TRITHOR Approved Installer to liaise with the Builder and ensure that the installation procedures are correctly performed so that the completed TRITHOR Termite Protection can be certified by the TRITHOR Approved Installer.

The TRITHOR Installer must provide advice to bricklayers on how to install the brickwork once the TRITHOR is in place.

### Builder's Responsibility

The Builder must ensure that:

1. the under-slab soil is levelled, and the vapour barrier membrane installed no higher than 25 mm around pipes;
2. all pipe penetrations are installed in their final position;
3. the slab reinforcement mesh is placed within the slab area and fixed on suitable 'chairs' at the correct height;
4. they are aware of the limitations of TRITHOR Termite Protection and its placement requirements; and
5. they inform the TRITHOR Approved Installer of any damage to, disturbance of, or misalignment of the TRITHOR Termite Protection prior to the pouring of the slab. (The TRITHOR Approved Installer will then rectify.)

### Installation Procedures – Cavity Wall Perimeters

1. Determine the width of TRITHOR required by liaising with the builder and/ or bricklayers and determine how many bricks are to be installed down to the footing for the DPC level. This may vary due to step-downs so plan ahead. Typically, 300 mm TRITHOR Strips are required.
2. Install the TRITHOR to a maximum width of 70 mm on the top of the slab (minimum 50 mm), fixing it to the slab with Ramset nails and washers (preferred), or concrete nails, approximately every 350 - 400 mm; or use an approved glue system.
3. Ensure any corner overlaps are nailed to minimise movement of the TRITHOR when the timber frames are erected.
4. Ensure overlap of 50 – 75 mm is allowed for areas such as bay windows and nail these too.
5. TRITHOR can also be effectively adhered to concrete slabs or brick and block work with a generous application of TRITHOR Foam

Adhesive on the masonry surface before positioning. The TRITHOR is then firmly pressed into position.

6. Concrete/ Ramset nails with washers are used near all corners to assist with fixing and to allow tensioning between corners.
7. Pre-formed corners (strongly recommended) should be installed prior to gluing longer perimeter sections, or the corners may be folded after gluing, as part of the installation.
8. When nailing, ensure the nail heads finish flush with the slab and protect against gaps or undulations when the frames are stood.
9. Once the system is in place, the bricklayer can lay the bricks to the footing to the height of the DPC/ Flashing. The TRITHOR then needs to be laid on to the brickwork paying careful attention to corners. Corners, including bay windows, are fixed with an approved adhesive, and/ or a quality cloth tape.
10. Prior to completion, remove any off-cuts and note if you will be required to make further site visits; e.g., to install across a driveway, wheelchair access, patios, columns, and isolated piers.
11. A Meter Box sticker is placed once installation is complete in accord with AS 3660.1.

#### Alternate Method – Glue

The use of **TRITHOR Adhesive** is approved as an alternative installation method.

The TRITHOR is installed after the first layer of bricks is placed. This enables the TRITHOR to be glued to the face of the slab and laid over the top brick. This gives a professional installation and allows the installer to position the TRITHOR correctly to the face of the bricks.

The TRITHOR is nailed at 150 mm centres to the face of the slab in addition to the glue to ensure a secure grip.

In the event of a ripple occurring when using the glue, this must be corrected.

**NOVITHOR products may also be used in association with the TRITHOR.**

#### One Brick Rebate

Any extra TRITHOR is placed into the wall cavity. If the finished brickwork is comprised of face bricks, TRITHOR Termite Protection should be set inside of the external brick wall.

When the strip is to be laid before the first layer of bricks, then the TRITHOR needs to be nailed to the framing timbers to protect it until the bricks are laid. Any excess is pushed into the wall cavity.

Secure it to the slab with concrete nails or Ramset nails with washers. Extend the TRITHOR strip to the slab edge and leave flush with the first brick or step-down. Make sure the TRITHOR extends to the slab edge. The damp-proof course is laid above the TRITHOR at the weephole.

Where the installation may be compromised by a build-up of soil to the weephole level, or rendering of the bricks, it is recommended that a pavement/ mowing strip is installed with the TRITHOR System above the mowing strip.

#### Two Brick Rebate

The perimeter strip of TRITHOR Termite Protection is secured to the top of the slab after the concrete is cured with nails at 350 - 400 mm intervals.

Usually, the TRITHOR is laid prior to the frame or internal course of brick work. Secure it to the slab with concrete nails or Ramset nails with washers. Extend the TRITHOR strip to the slab edge and nail down to the slab edge. Leave the leading-edge flush with the first brick or step-down. Make sure the TRITHOR extends to the outer edge of the masonry wall. The damp-proof is laid above the TRITHOR at the weephole.

#### Important

When joining the TRITHOR Strips, a *minimum* 50 - 75 mm overlap should be allowed. This applies equally to joins along a wall, at a corner or where a repair patch is required.

Always ensure TRITHOR Termite Protection is laid above the proposed level of future

landscaping and prior to the laying of mowing strips or pavements.

Where external walls are face brick and the mortar is pointed or raked, the TRITHOR strip may be laid 3 - 5 mm off the edge of the brick.

Situations may arise where the builder has stood the frames prior to the installation of TRITHOR Termite Protection. The TRITHOR Termite Protection can then be installed to the vertical face of the rebate using punched builders strapping all the way around the perimeter to get the required compression.

NB The strapping must continue around the entire perimeter with no gaps.

## USE OF STRAPPING

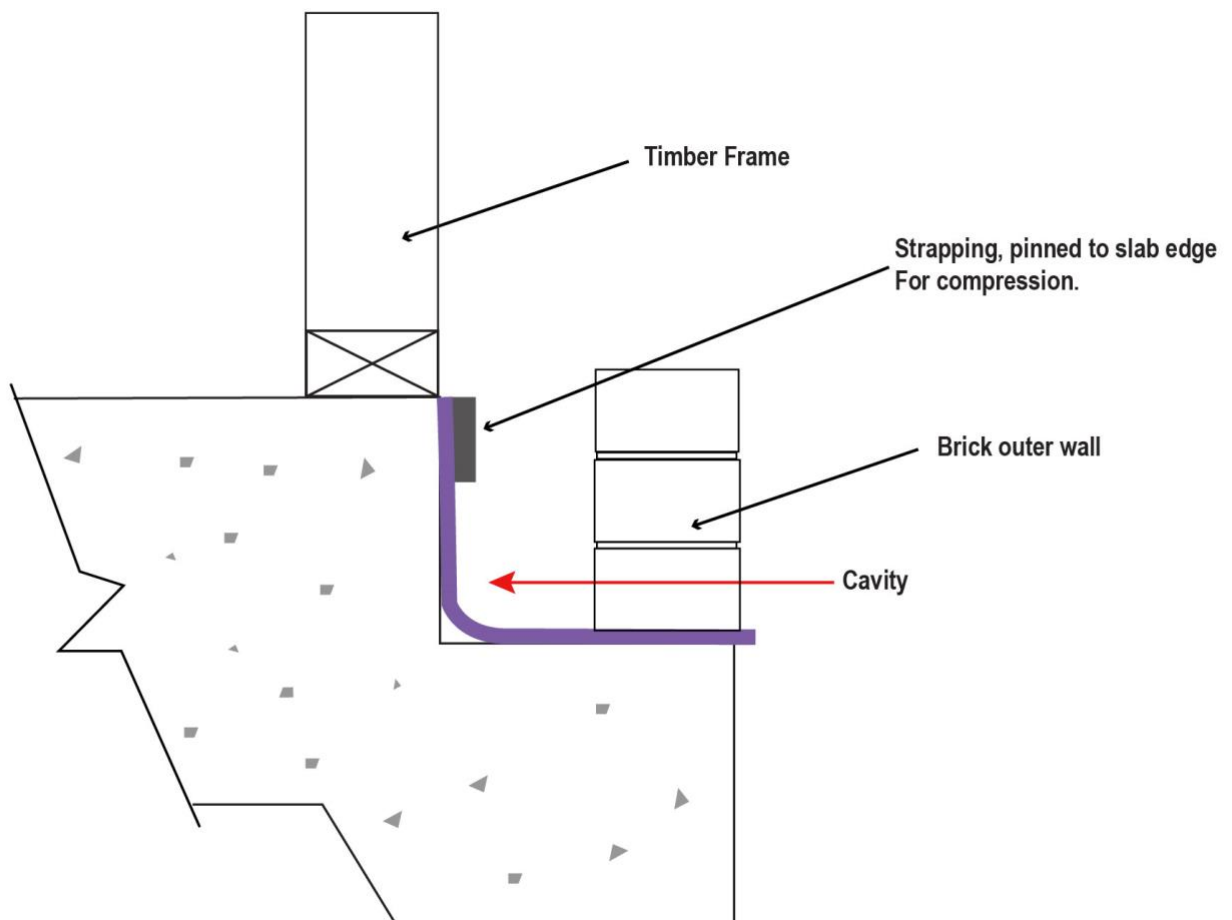

### TERMITE SHEET PROTECTING A ONE BRICK REBATE

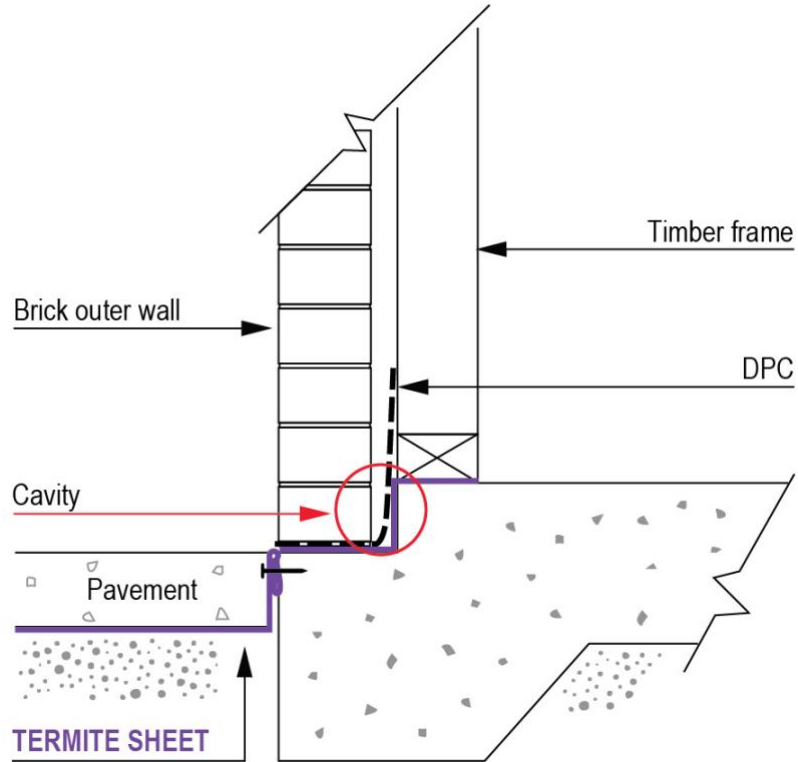

### TERMITE SHEET PROTECTING A TWO BRICK REBATE

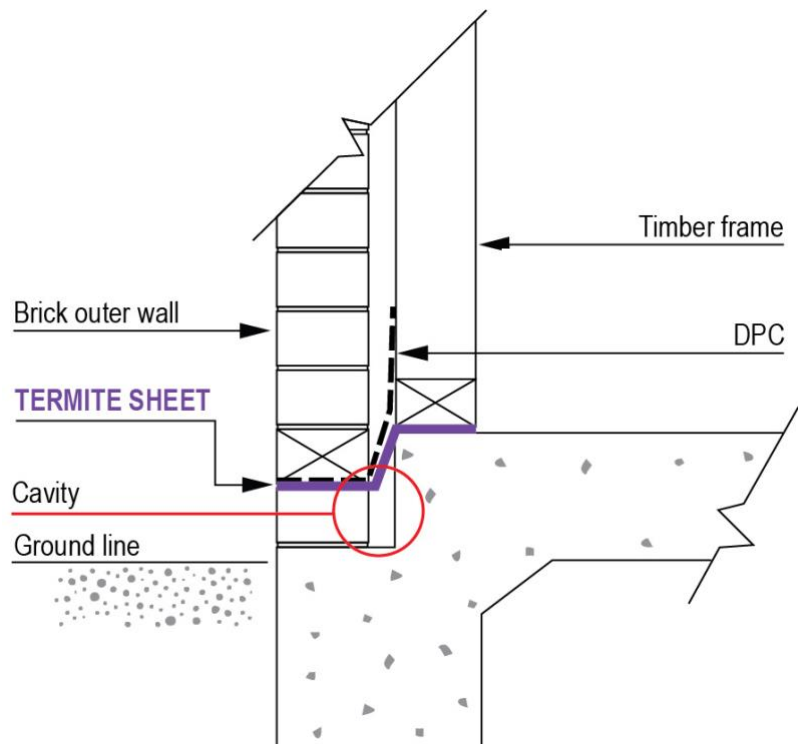

### TERMITE SHEET PROTECTING A ONE BRICK REBATE

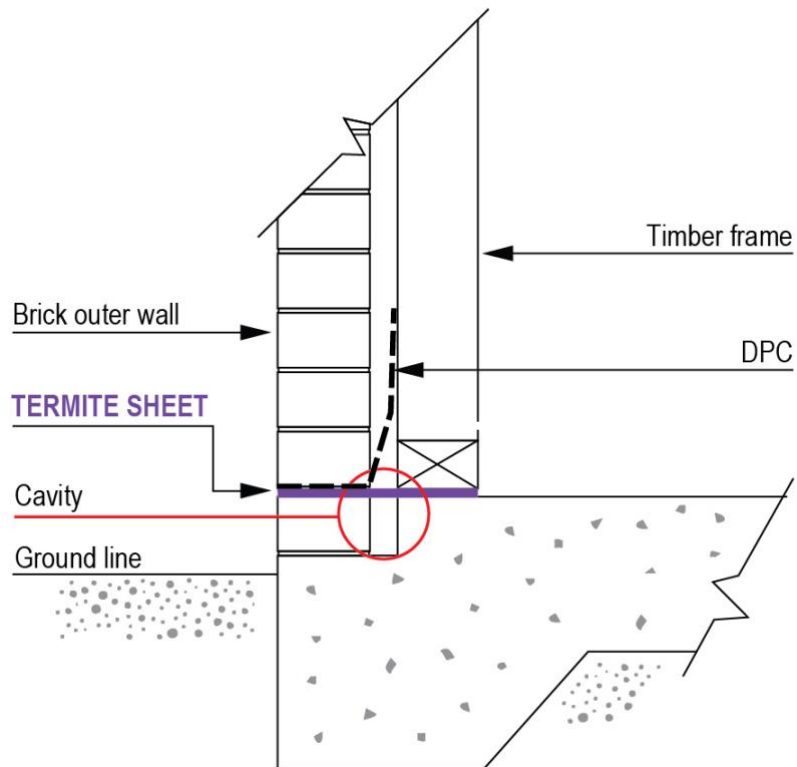

This detail is only used where the internal area is a non-inhabitable area e.g.: Garage.

### TERMITE SHEET PROTECTING A TWO BRICK REBATE

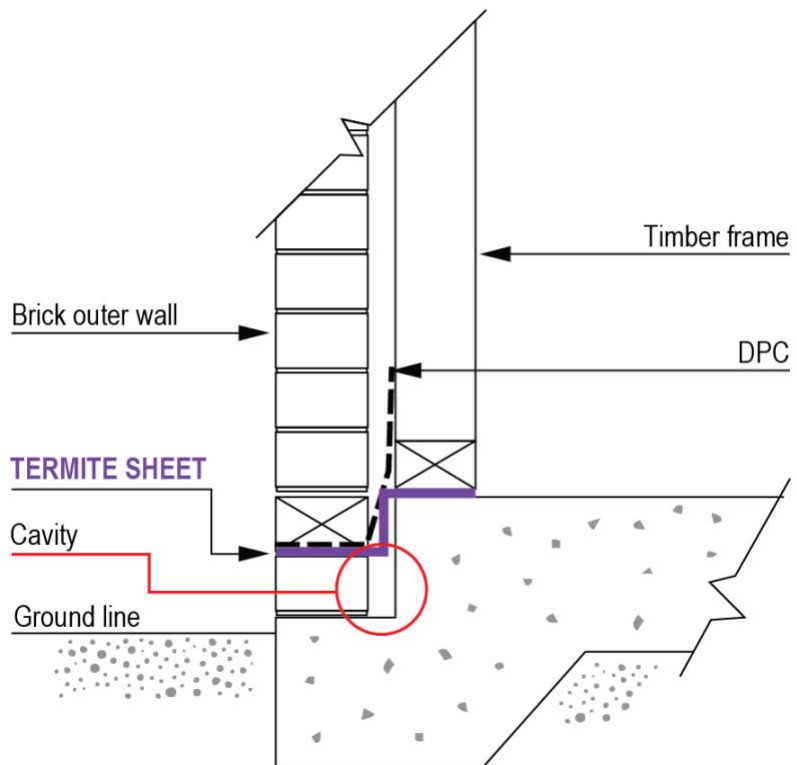

## Inspection Zones

The *Australian Standard AS 3660.1 Termite management – New building work*, refers to a 75 mm inspection zone between the exposed edge of a termite system in the outer wall of a building and the grade level beneath it.

The purpose of this inspection zone is to ensure that sufficient un-occluded surface exists to allow easy identification of termite mud tubes up the outer wall structure during a termite inspection. It was decided at the time by the Standards Committee that a distance of 75 mm (the depth of one standard building brick) would allow for changing grade levels due to gardening activities in adjacent soil, the depth of growing grass and so on, while still leaving sufficient un-occluded surface to allow for efficient inspection.

Where the grade is fixed and unchanging against the wall surface, such as in the case of concrete or paved pathways, patios, and driveways, this inspection zone may be reduced. This is particularly important where step-downs in doorways and windows occur.

With installations of TRITHOR Termite Protection, where hard surfaces such as concrete or paving exist, this inspection zone may be reduced to a minimum distance of 25 mm between the outer exposed edge of the TRITHOR and the top surface of the concrete or paving. This distance is considered adequate to allow for identification of termite mud tubes by those trained to do so, or by an observant property owner

## Step-downs

Steps downs need to be completely protected with TRITHOR.

Before installing TRITHOR you need to clean off any excess mortar from the top layer of bricks and continue down the vertical face of the internal brickwork. This better allows for TRITHOR to be fitted between the edge of the concrete slab and the bricks. A 400 mm length of TRITHOR is used on internal corners and is secured to the brickwork with concrete nails. The perimeter TRITHOR is then cut to shape and secured over this. Pre-formed corners are available and recommended to make this process simpler, quicker, and more effective.

All internal step-down installations must be integrated with the cavity protection to prevent concealed termite entry.

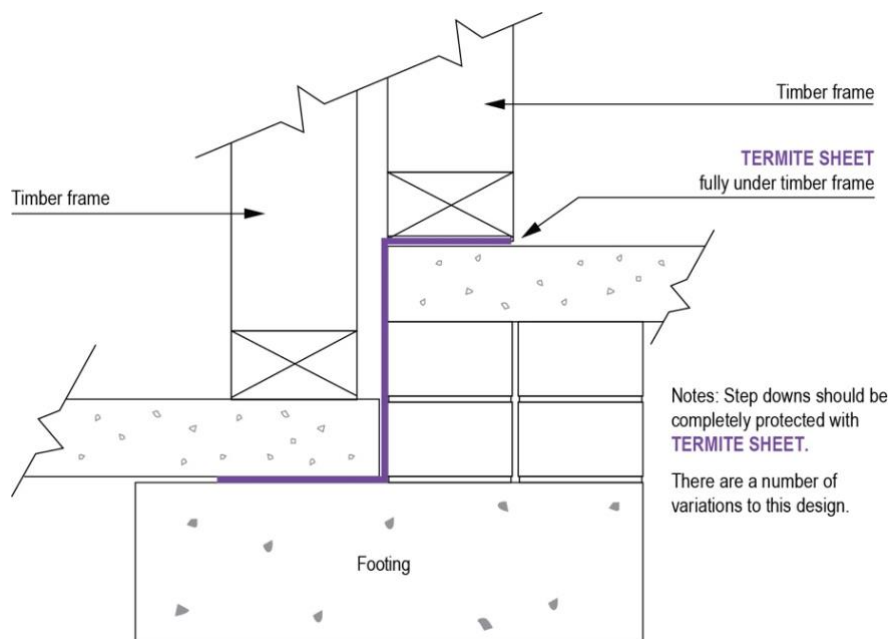

## Vertical Stepdown Detail

### Slab design requirement

Partial drop edge beam (DEB) required on high side of step down, minimum 450 mm length.

Stage 1.

- TRITHOR sheet to be installed as per normal detail on high side of step down. Note: TRITHOR sheet to be sealed with NOVITHOR™ Flex-gel onto the slab at the end cut of the sheet
- TRITHOR sheet on the lower section of the slab to be cut and sealed with NOVITHOR Flex-gel at the vertical step-up. Note: Sheet needs to be cut in-line with the step-up in the slab.

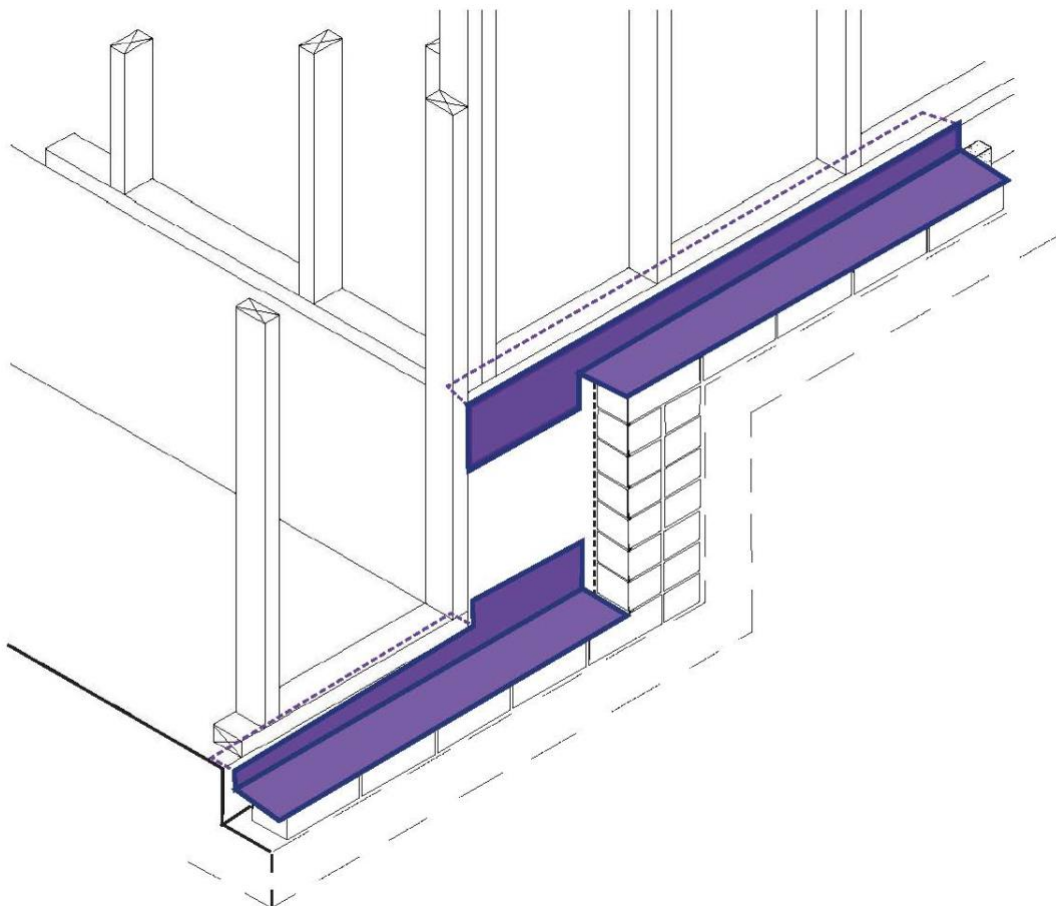

Stage 2.

- Brick layer is to create a vertical joint in the brick work and lay the first course of bricks on both levels. The vertical joint in the brick work should be a minimum of 230 mm from the internal step-in slab.



Stage 3.

- The upper section of the TRITHOR sheet needs to be cut in line with the vertical control joint in the brick work to allow the sheet to lay flat against the slab rebate. Note: Do not over cut.
- The upper section of the TRITHOR sheet needs to be sealed using NOVITHOR Flex-gel and nailed to the vertical edge of the slab rebate
- The lower section of the TRITHOR sheet is to be sealed with NOVITHOR Flex-gel and nailed to the vertical edge of slab rebate.

Stage 4.

- Place a gusset piece of TRITHOR between the upper and lower sections of the TRITHOR sheeting, seal, and nail the gusset sheet against the slab rebate and onto the face end of the brick work. Glue all joints of the TRITHOR sheeting. Ensure all joints are free of gaps and or folds.

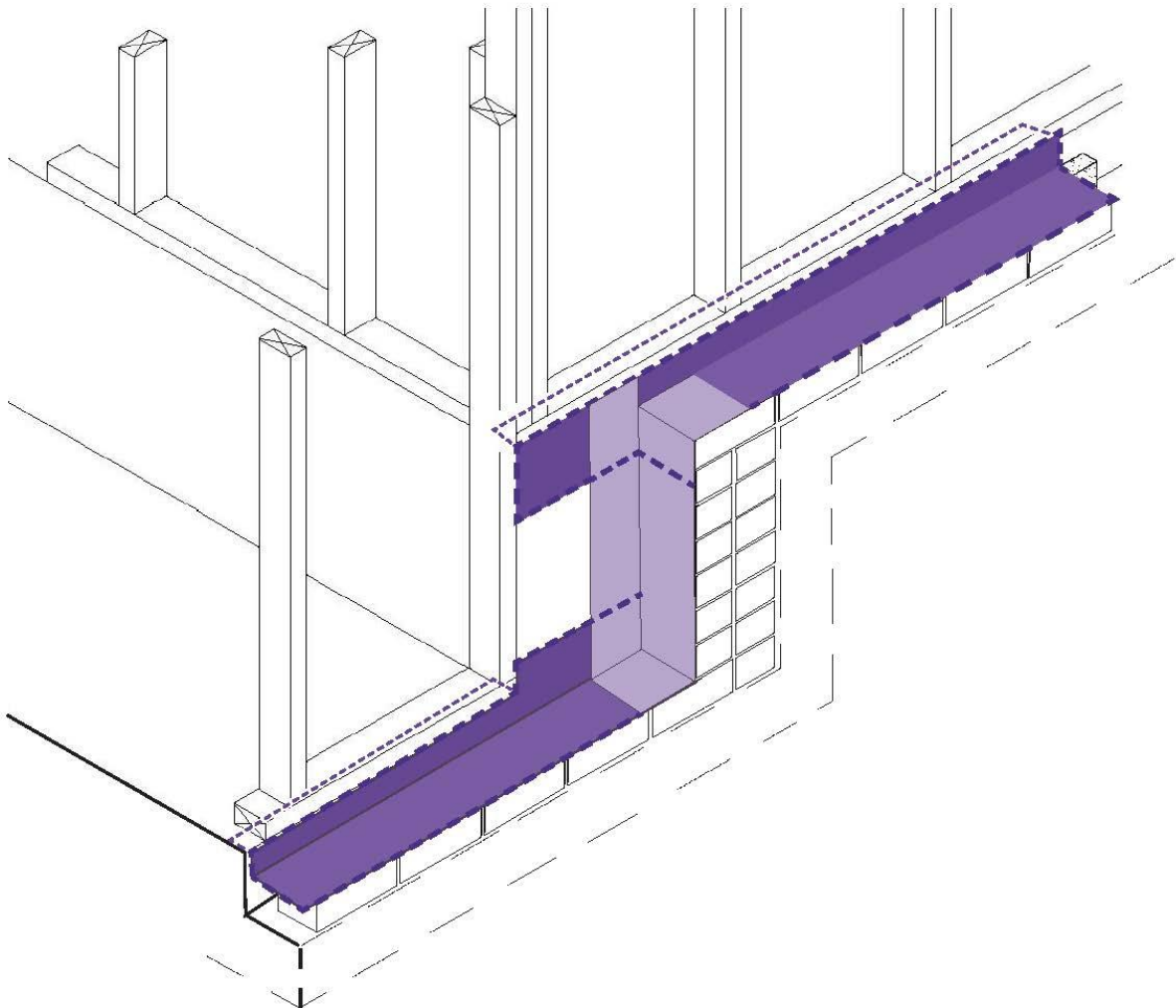

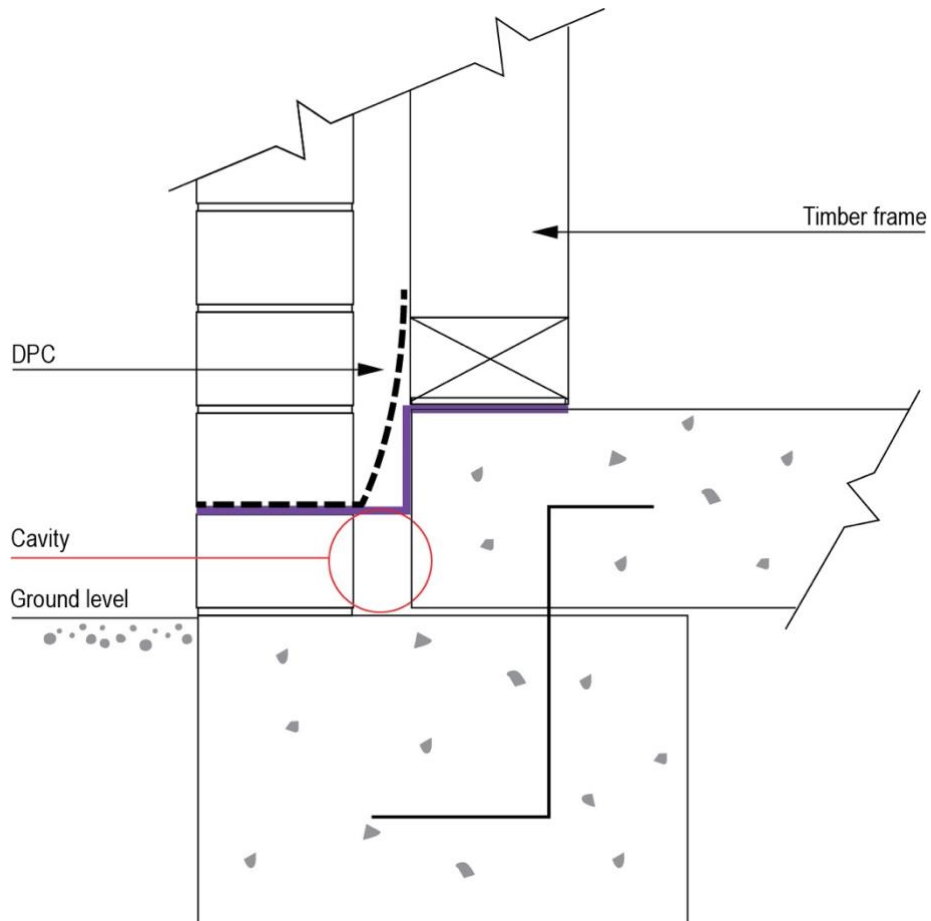

The minimum Inspection Zone in this situation is 25 mm when it abuts a hard surface, otherwise it is 75 mm minimum.

### TERMITE PROTECTION SYSTEM PROTECTING IN-FILL SLAB

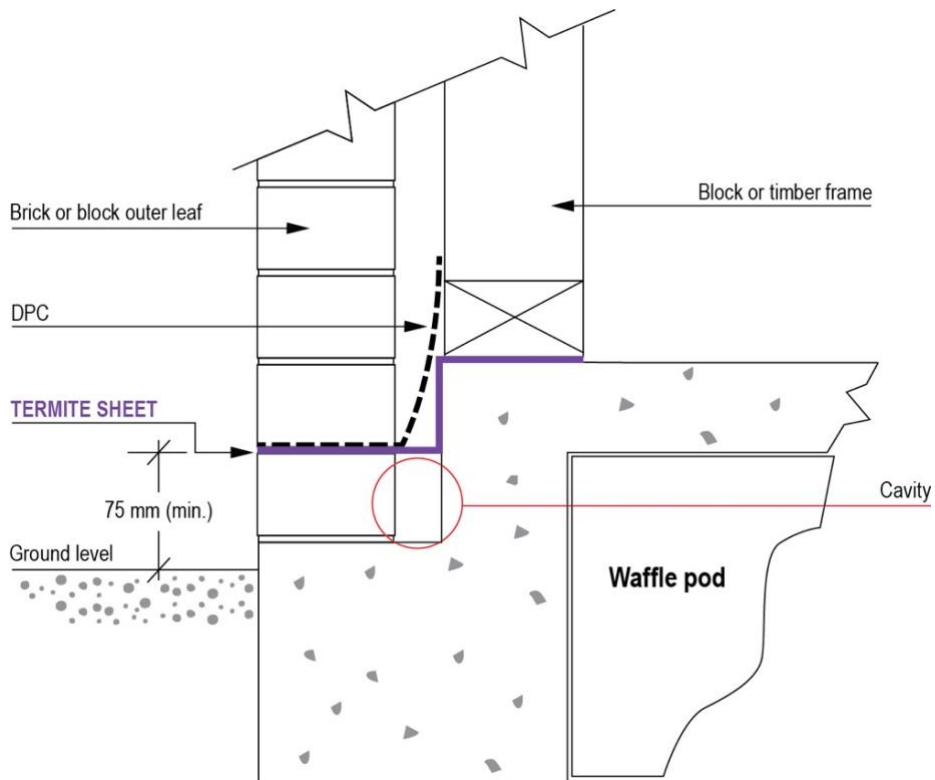
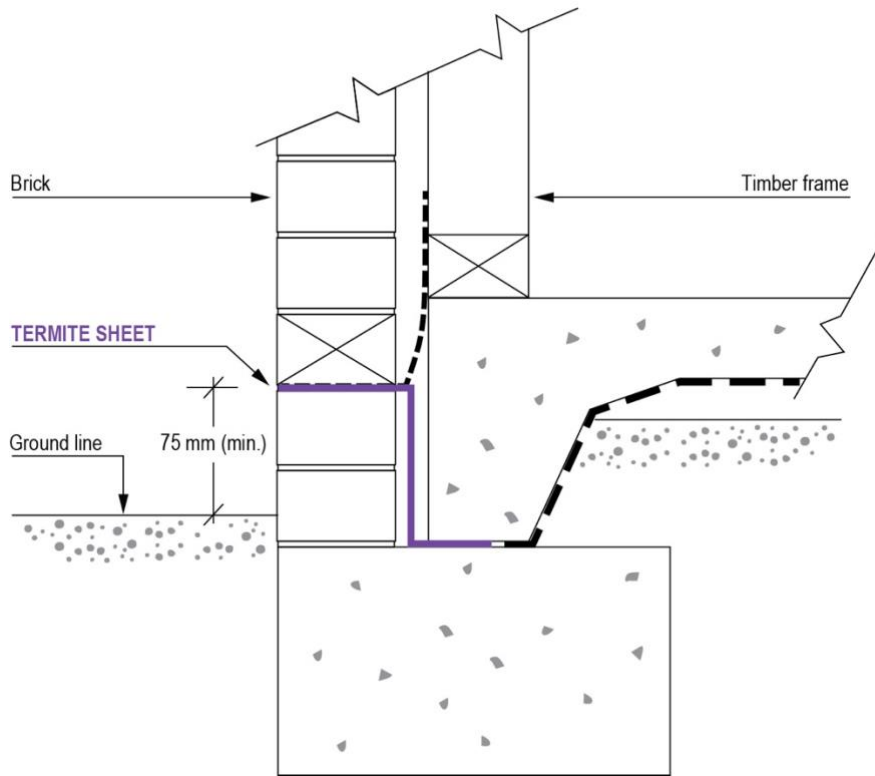

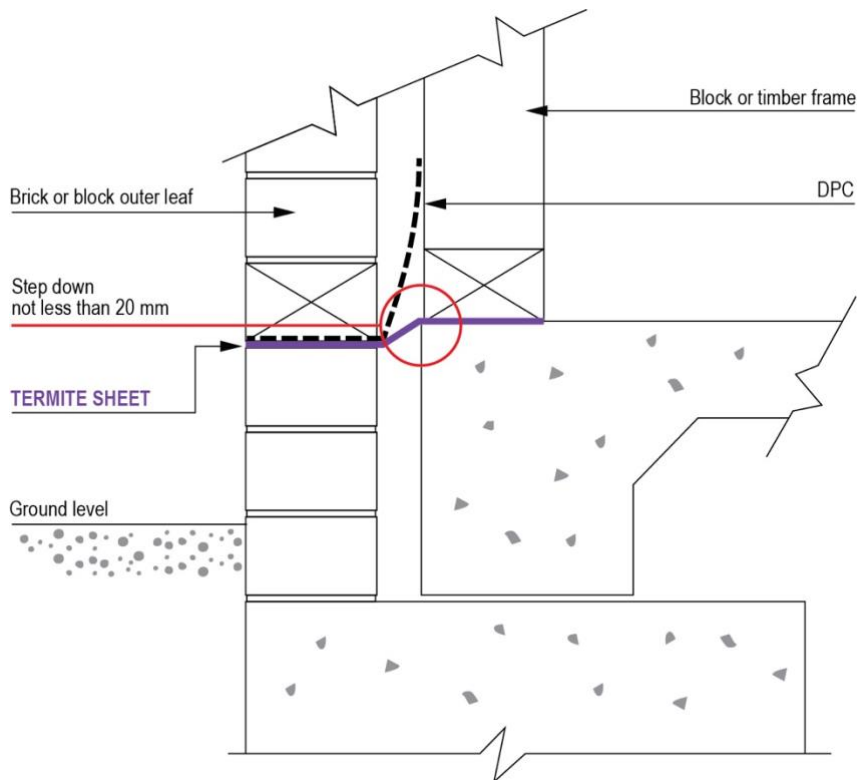
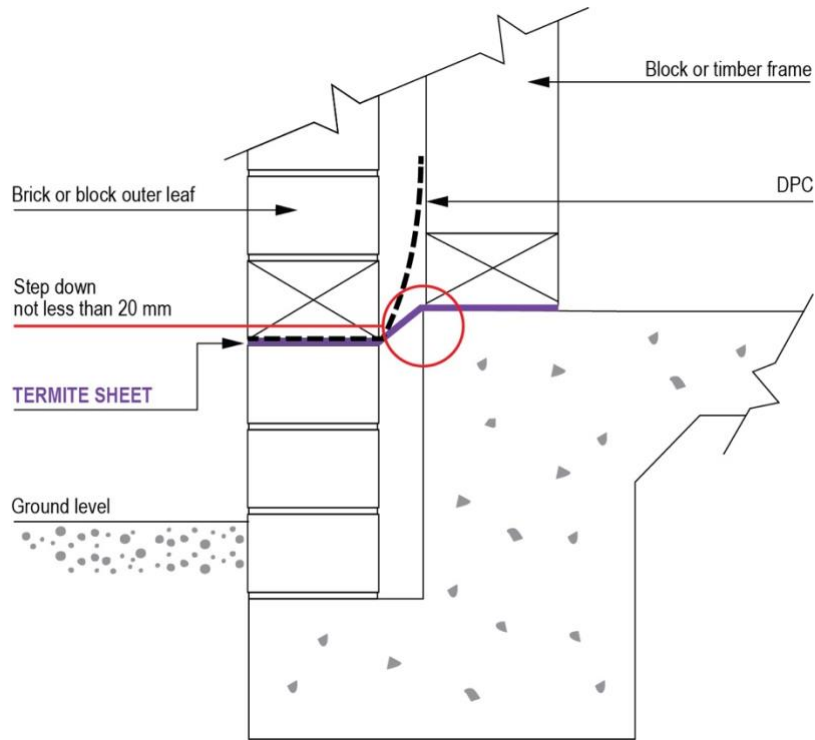

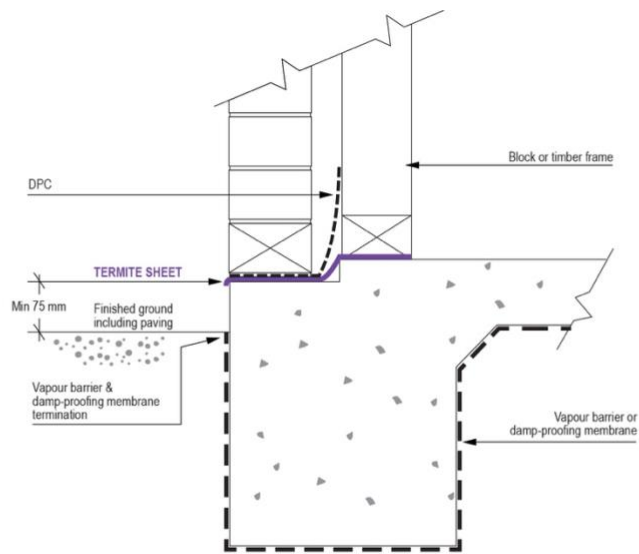

(a) Minimum rebate for cavity masonry or veneer wall

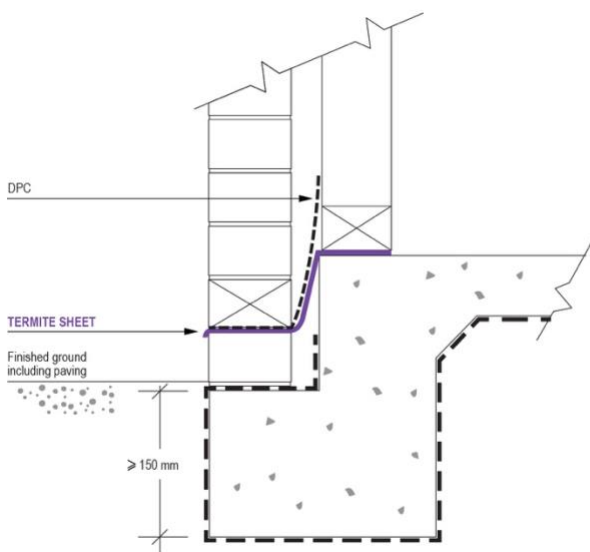

(b) Deep edge rebate alternative

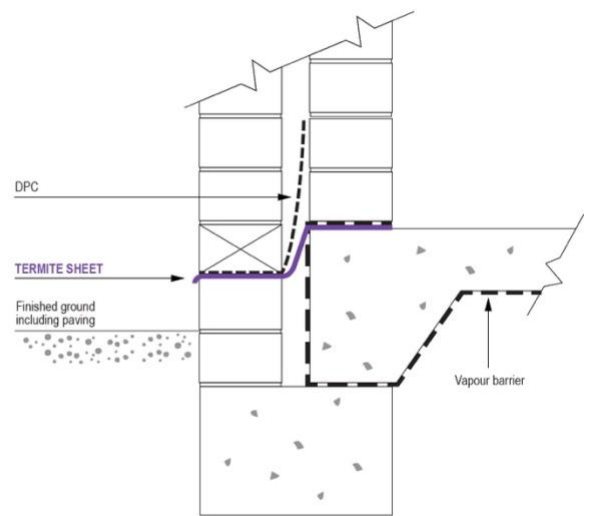

(c) Masonry alternative

The minimum Inspection Zone in this situation is 25 mm when it abuts a hard surface, otherwise it is 75 mm minimum.

**TERMITE PROTECTION SYSTEM PROTECTING IN-FILL SLAB**

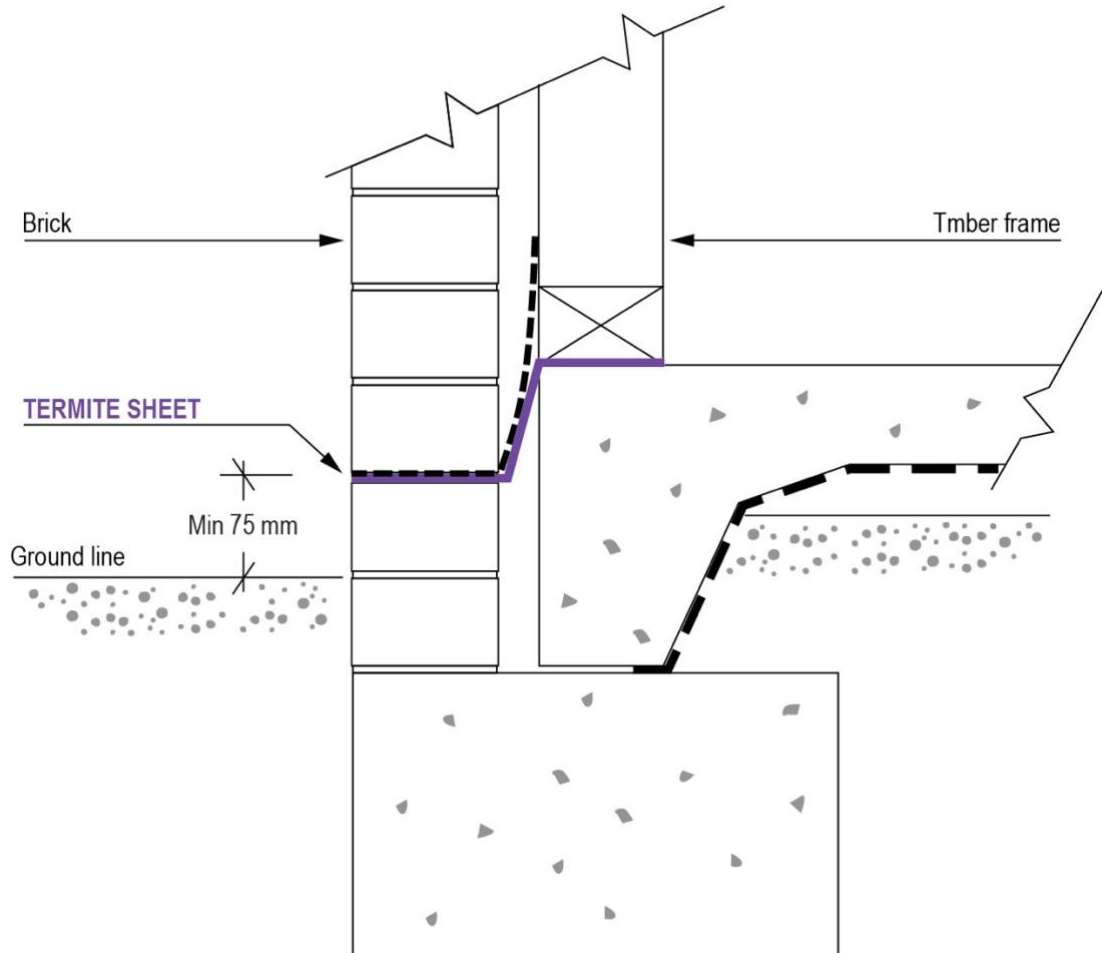

**INSTALLATION**

**STEP 1:  
PLACE TERMITE SHEET  
OVER PIPE**

**STEP 2:  
SECURE (2) ZIP TIES**

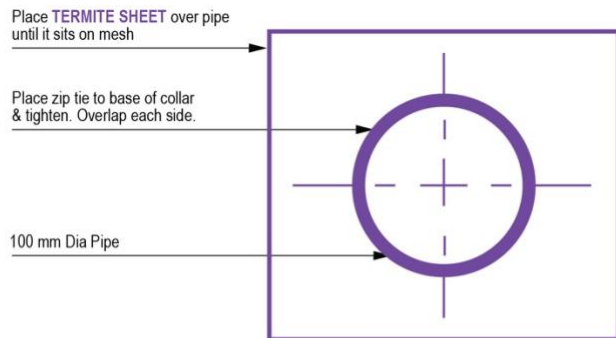

**SECTION DETAIL BEFORE CONCRETE POUR**

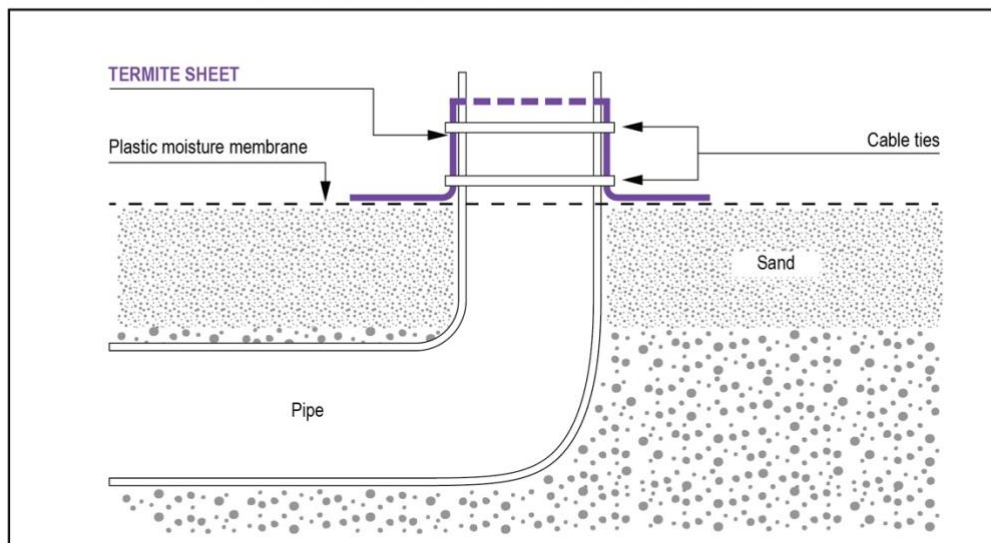

**SECTION DETAIL AFTER CONCRETE POUR**

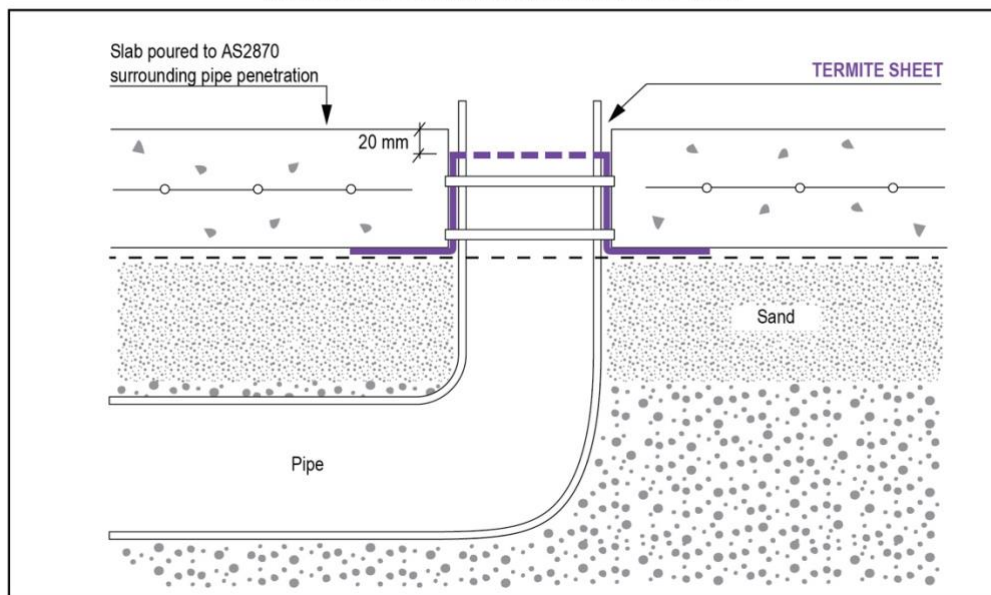

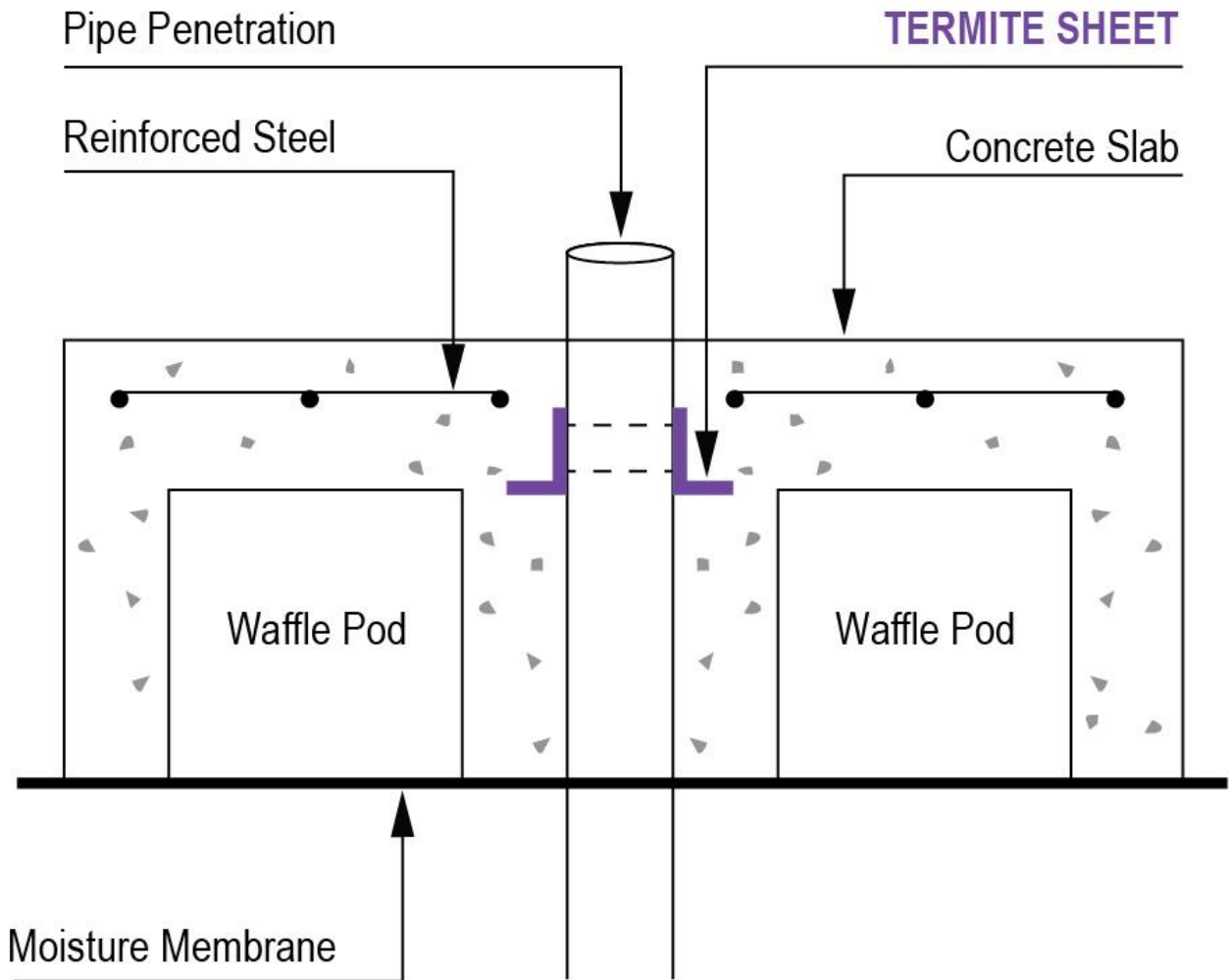



### Rendered Walls

When the outer wall is cement rendered, ensure that, where the TRITHOR meets the wall perimeter, a

V-joint is cut into the render, to avoid cracking, then detail the inspection point on the wall.

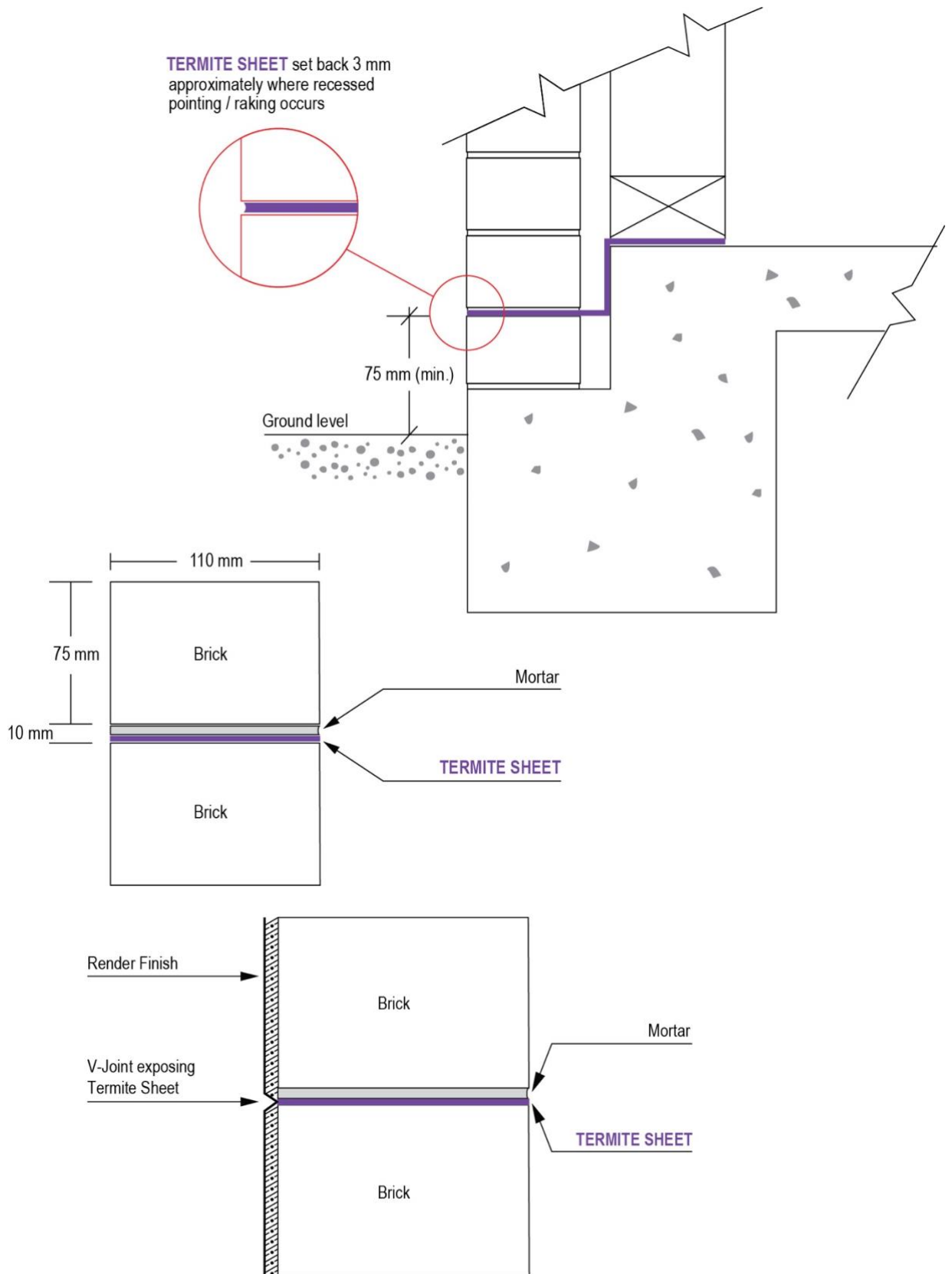

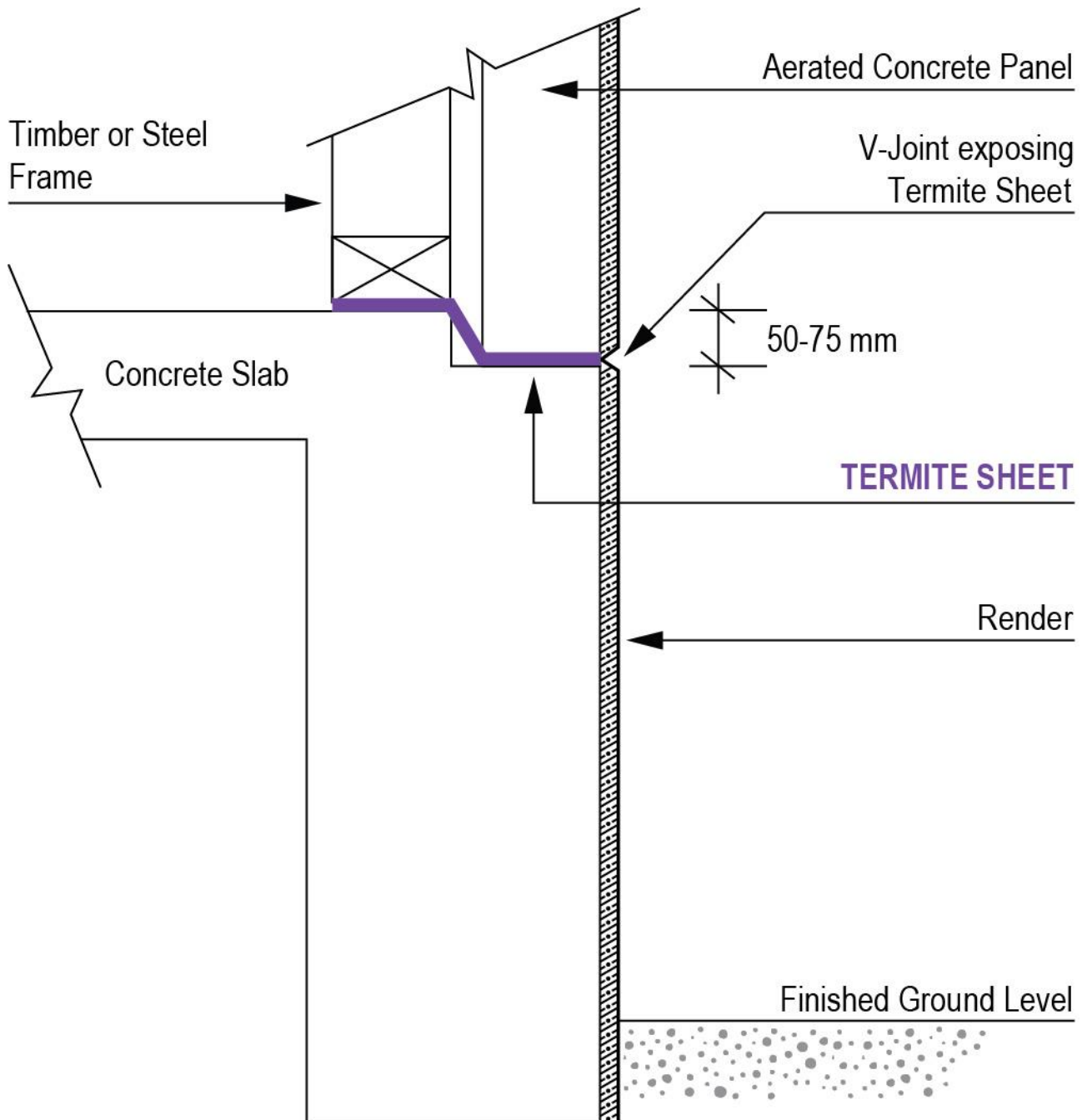

## Corner Details

Pre-formed corners are supplied for both internal and external corners of standard slabs. Corners require special care and attention to detail.

**Pre-formed corners should always be used since they make this process simpler, quicker, and more effective.**

In some rare cases, it may be necessary to form corners on site, in which case they are formed as

below, (unless approved otherwise by Ensystem in writing).

Sometimes, using this method, a slab edge rebate will require a course of bricks is laid before you can commence the perimeter installation. Of course, for in-fill slabs the reverse procedure to that illustrated below will apply.

**The process for making an INTERNAL CORNER is identical to that shown below.**

### TERMITE PROTECTION SYSTEM - CORNER DETAIL

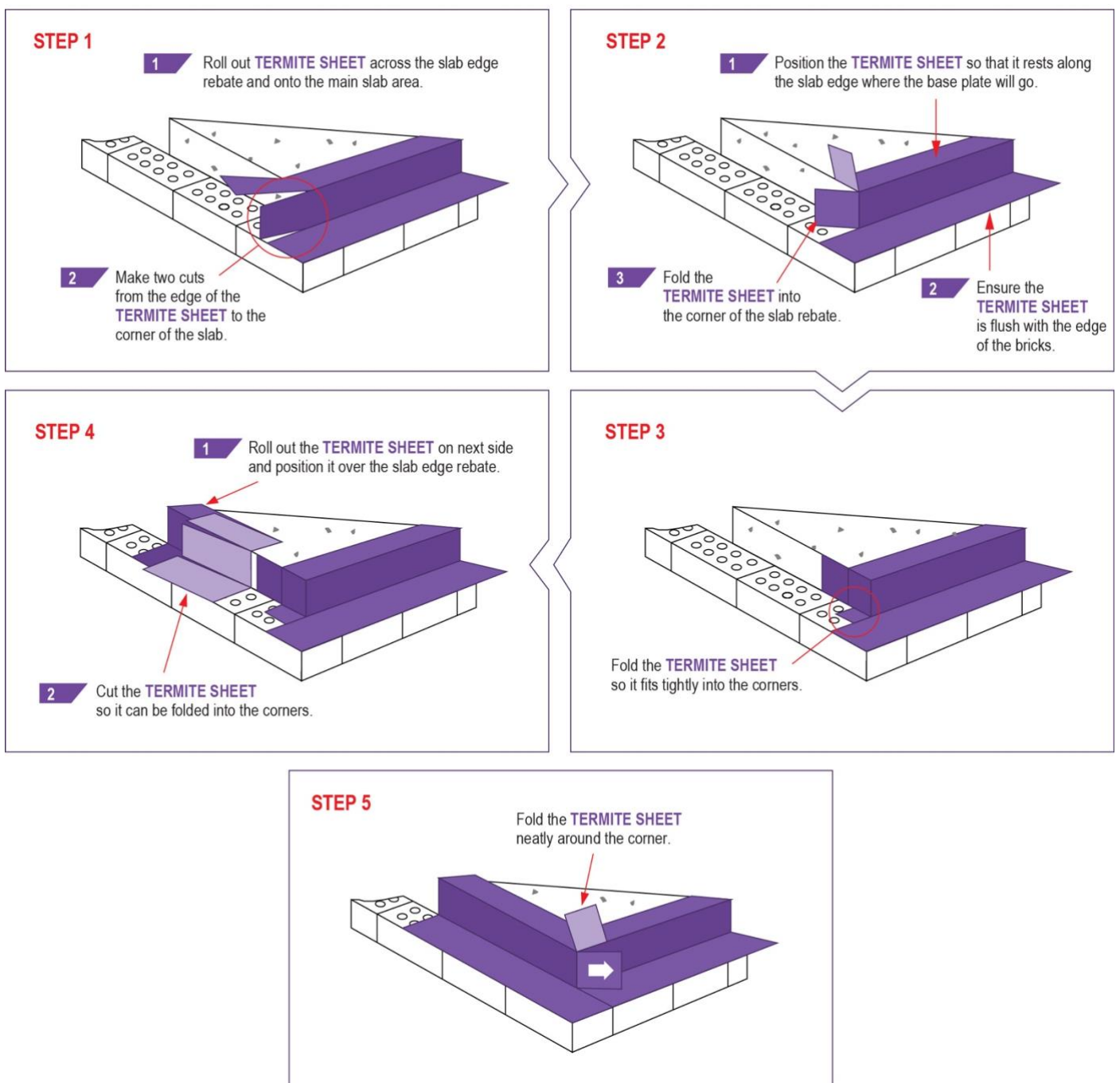

## Joining TRITHOR

When joining TRITHOR strips to each other or to pre-formed corners, three options are available.

**Glue** TRITHOR is overlapped by a minimum of 50 - 75 mm and glued at the joins.

TRITHOR Adhesive must be applied to both surfaces that are to be glued together. Apply a thorough coating of the adhesive and leave for 15 minutes during which period the glue will dry and go tacky. The exact time required will depend on prevailing climatic conditions. Once the TRITHOR Adhesive has gone 'tacky' firmly press the two surfaces to together and hold until they are firmly secured.

**Nailing** When using TRITHOR Pre-formed Corners, the corners must be placed first. The TRITHOR Strips can then be run right to the edge of the corner of the slab, so they fully overlap the Pre-formed Corner. The Strips are then nailed on to the top of the slab, and two more nails are placed into the face of the slab to hold firmly in position with glue.

If using this method for joining strips along the edge of the slab, then the strips must be overlapped by a minimum of 50 - 75 mm, and two nails must be placed on top of the join on the slab, together with two nails to secure them to the face of the slab.

## Pipe/ Service Penetrations

Pipe penetrations should be protected with TRITHOR Collars.

TRITHOR Collars are available in two sizes, 120 mm for pipes up to 100 mm diameter, and 60 mm for pipes up to 50 mm diameter.

For larger pipes, two 120 mm Collars can be cut and joined together by applying TRITHOR Adhesive to the lap joint of the adjoining Collar.

These **MUST** be secured in place using two cable ties.

### TRITHOR Collars

When Installing TRITHOR Collars, take care not to stretch or place unnecessary pressure on the joint seals. TRITHOR Collars are secured to the pipe with a two strong cable ties, positioned near the base and upper edge of the Collar's tube, and tightened with a set of pliers. TRITHOR Collars must be installed so that there are no gaps between the pipe and the Collar.

Where TRITHOR Collars are used in whole of slab installations, i.e., **TRITHOR Termite Protection PLUS**, the TRITHOR Collars should be taped horizontally to the full under slab TRITHOR Sheet to complete the moisture membrane.

**TRITHOR Collars must NEVER be taped at the top.**

## Electrical Conduits

Use **TRITHOR Collars** around all electrical conduits penetrating the slab for a length of about 100 mm.

Where conduits are in clusters, each penetration must be wrapped individually. When wrapping conduits, the yellow side of the TRITHOR must be facing outwards. Two cable ties are used to secure the TRITHOR wrap at the start and finish of the pipe.

## Horizontal Penetrations

A horizontal penetration is a right-angle insertion into the slab. It usually occurs where a service penetration goes through an edge beam or structural beam. This may allow concealed termite entry through any hollow building materials holding the service penetrations in place (e.g., copper or PVC pipes). All such hollow structures must be replaced or removed before installing TRITHOR Termite Protection.

## Multiple Penetrations

This is where there are several service penetrations that are in close proximity to each other. Often these consist of different pipe sizes. TRITHOR Collars are ideal in these cases. Treat each penetration separately.

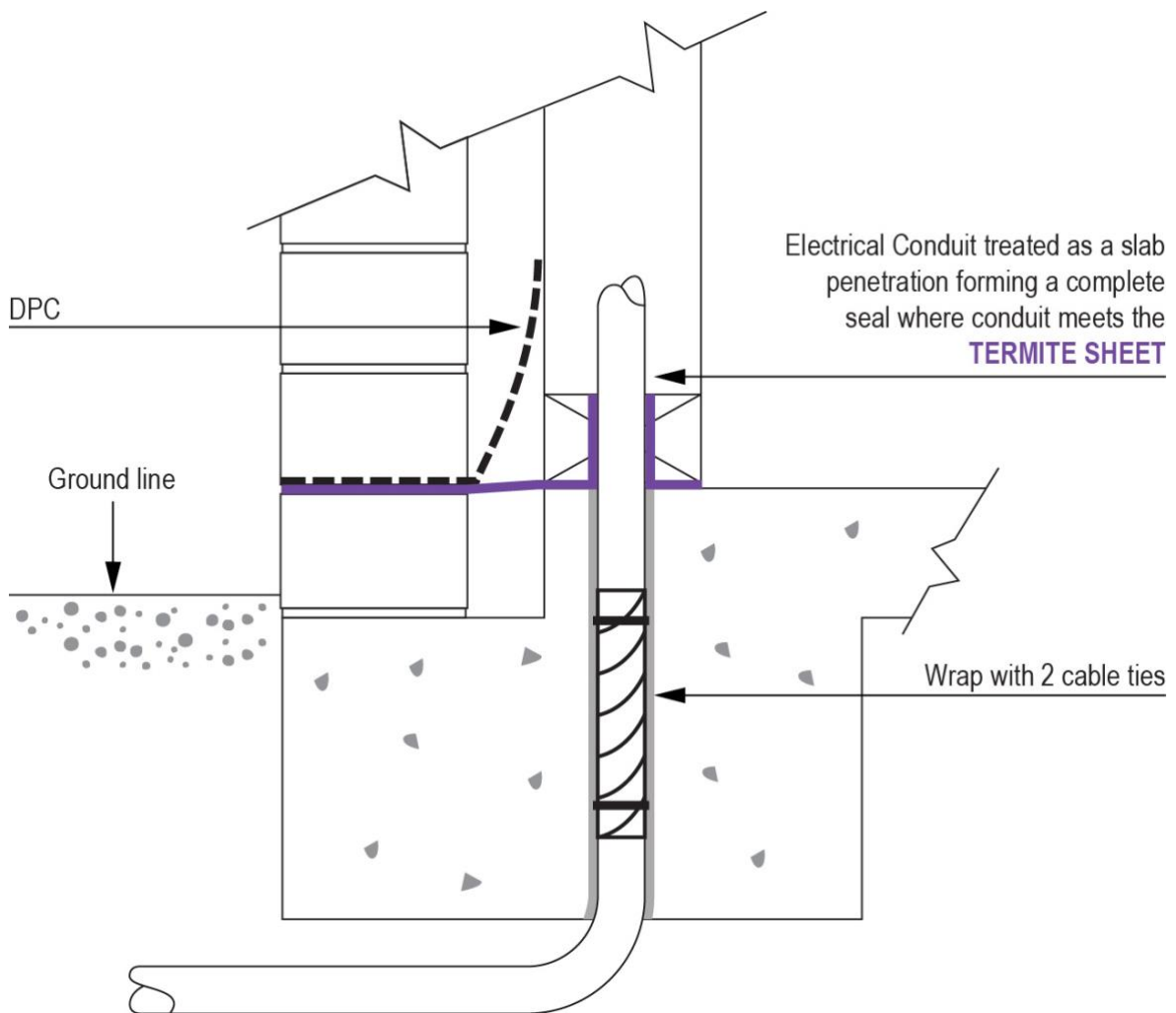

## Retaining Walls

Where a retaining wall forms part of the structure, TRITHOR Termite Protection should be installed down to, or preferably below the level of, the rubble. TRITHOR Termite Protection should be secured to the external concrete/

brickwork either by a concrete mowing strip or a concrete pathway.

**NB** When TRITHOR is installed in this manner, it is providing a Termite Protection System only. It does not form part of the tanking membrane.

### TERMITE PROTECTION SYSTEM FOR EXTERIOR WALL

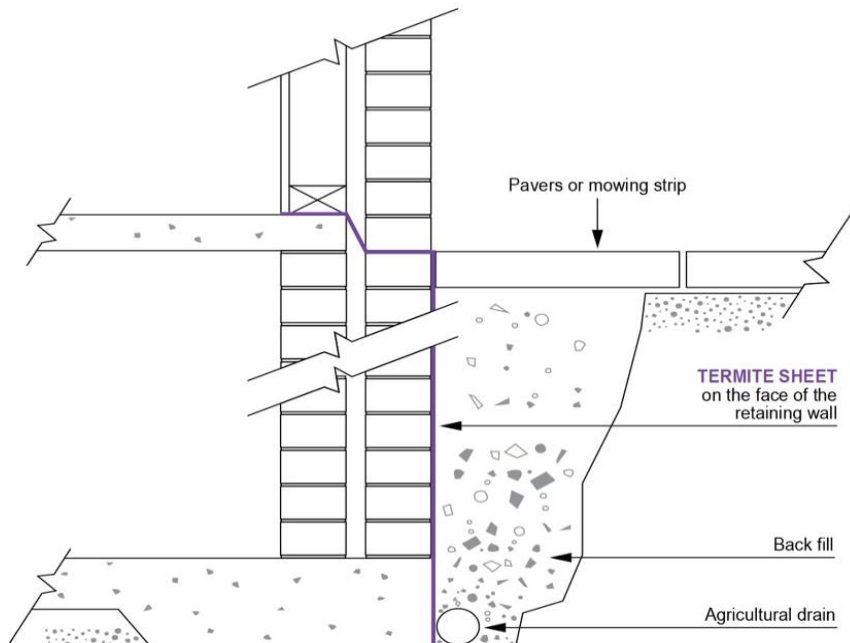

### TERMITE PROTECTION SYSTEM FOR RETAINING WALL

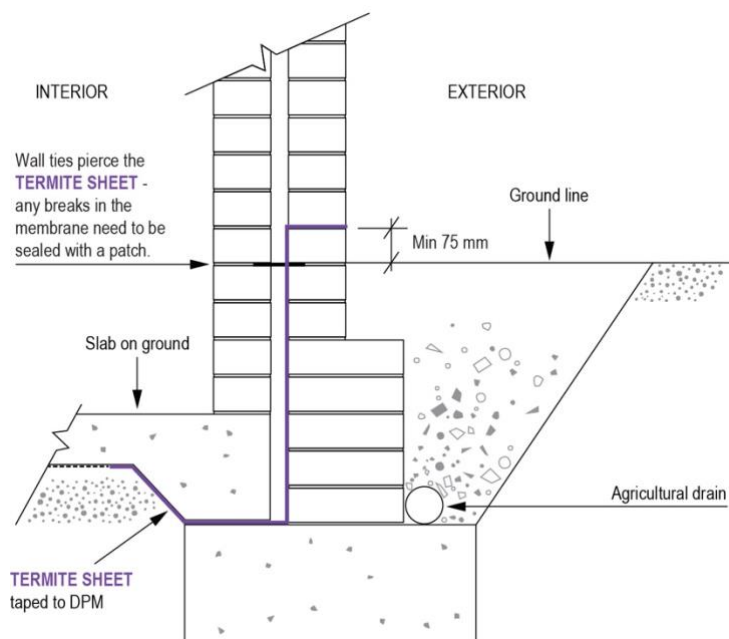

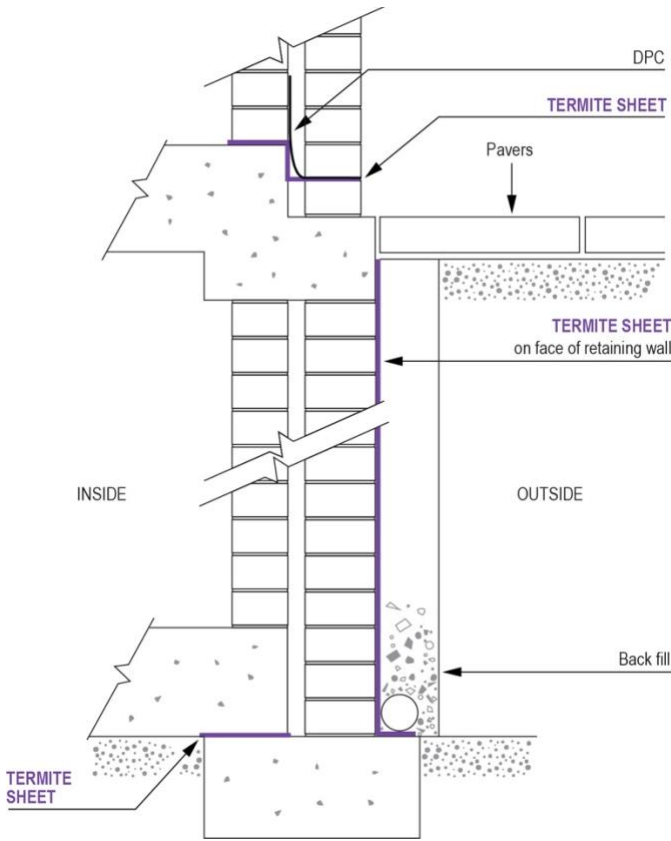

**TERMITE PROTECTION SYSTEM FOR RETAINING WALLS**

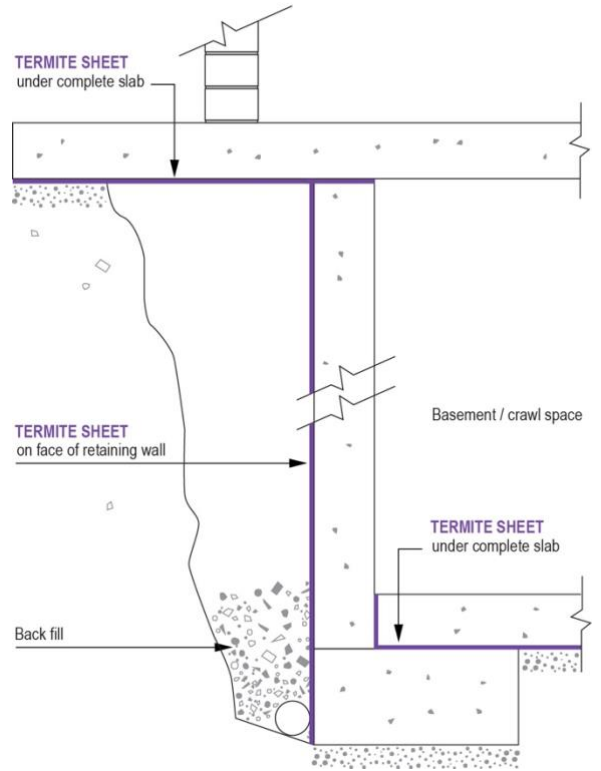

**TERMITE PROTECTION SYSTEM FOR RETAINING WALL**

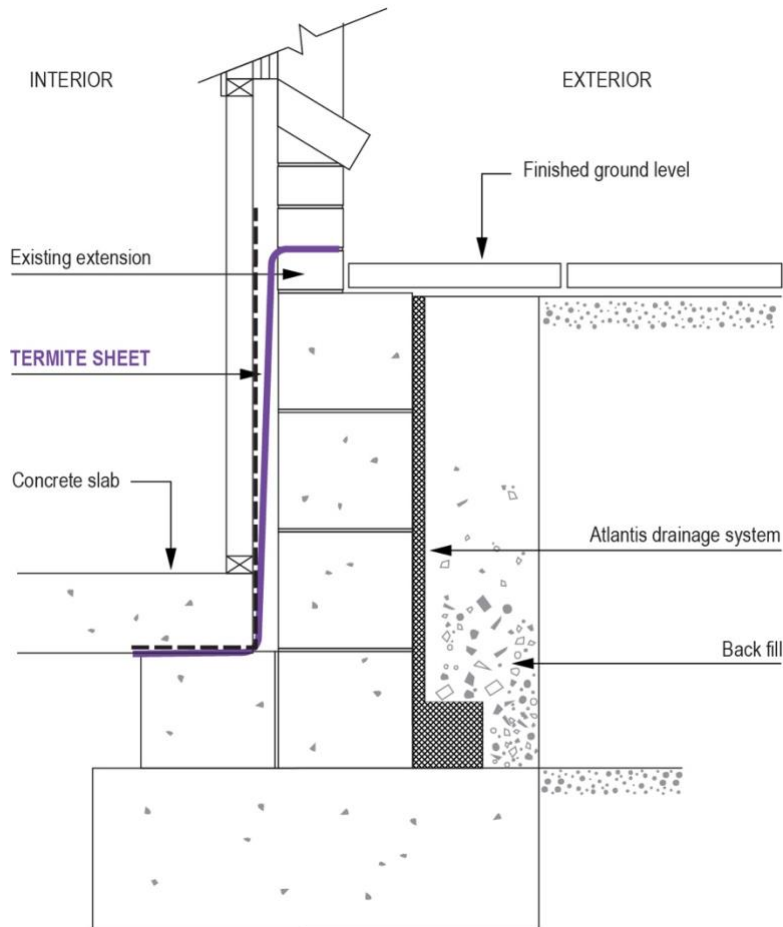

## Construction Joints

TRITHOR Termite Protection protects all types of construction joints. A minimum 250 mm or 300 mm wide strip of TRITHOR Termite Protection is installed under the joint and taped to the moisture membrane with an approved cloth tape prior to pouring the concrete.

The exception to this is for DOWEL JOINT – OPTION B below, where the requirement is a minimum width of 150 mm, folded in two, to give a width in the joint of 75 mm.

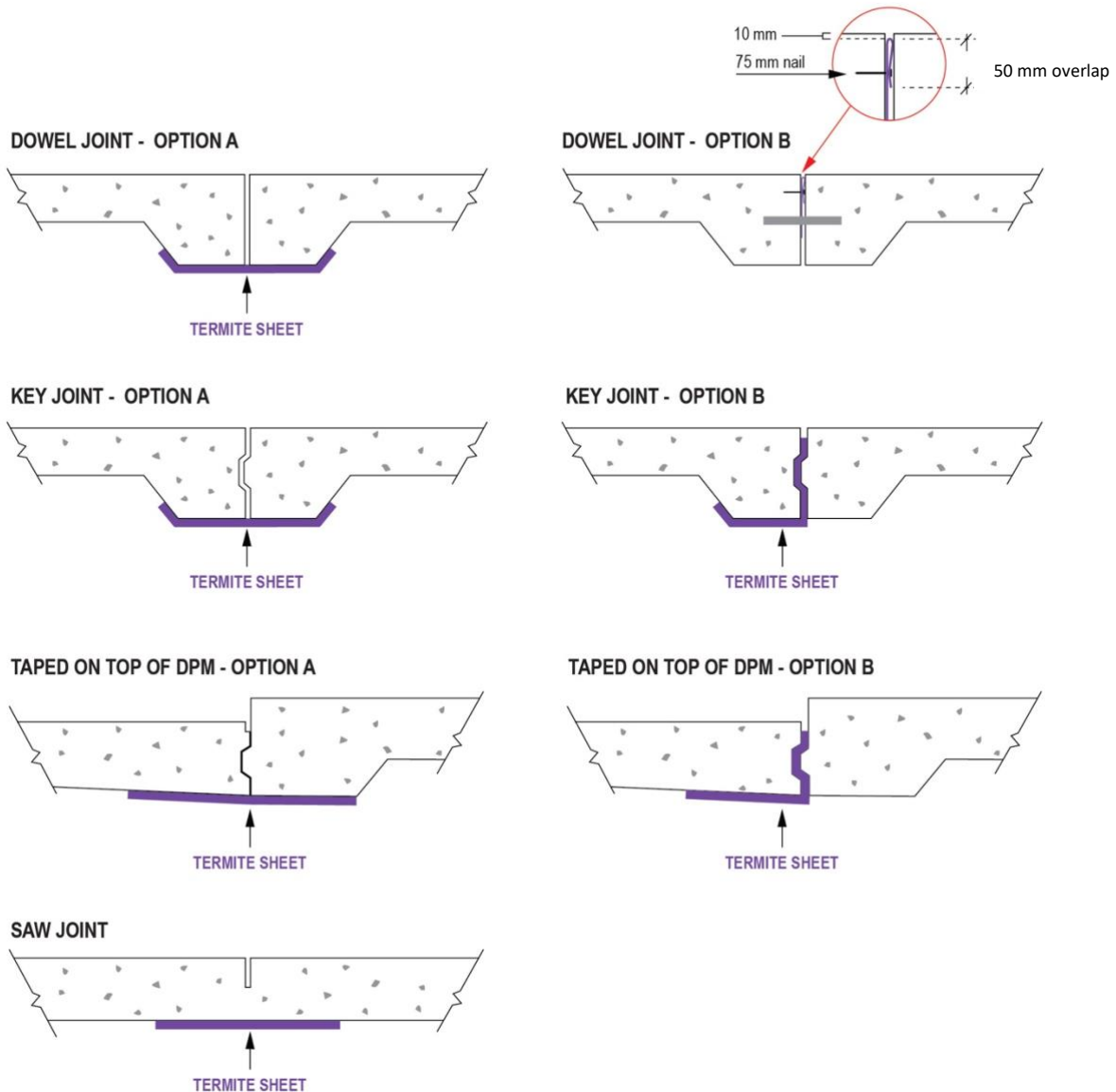



### Access Ramps

For access ramps, the TRITHOR is applied to the vertical face of the concrete slab prior to pouring the cement for the ramp.

A minimum strip of 250 mm wide TRITHOR is attached to the height of the slab and extended down to the footing and then taken horizontally under the ramp.

### Timber Flooring

The TRITHOR system is also used to protect timber floors when placed on concrete as illustrated here, or for pier construction. Note: This detail is only required when it cannot be confirmed the slab has been poured in accordance with AS2870.

**TERMITE PROTECTION SYSTEM PROTECTING WOODEN FLOOR ON CONCRETE SLAB**  
(TO BE USED WHEN SLAB NOT POURED IN ACCORDANCE WITH AS 2780)

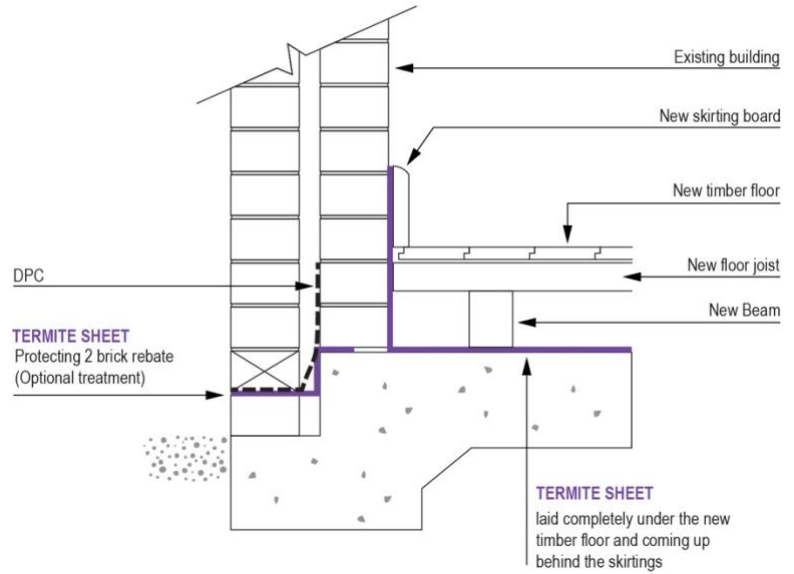

### Doors and Windows

Special attention to detail is required when installing TRITHOR for placement of doors or windows. It is recommended that the TRITHOR be glued to the concrete slab under the full length of

the window when there is no compression on the TRITHOR sheet. Nailing at 150 mm intervals is also recommended.

**TERMITE PROTECTION SYSTEM FOR DOOR OR WINDOW OPENING**

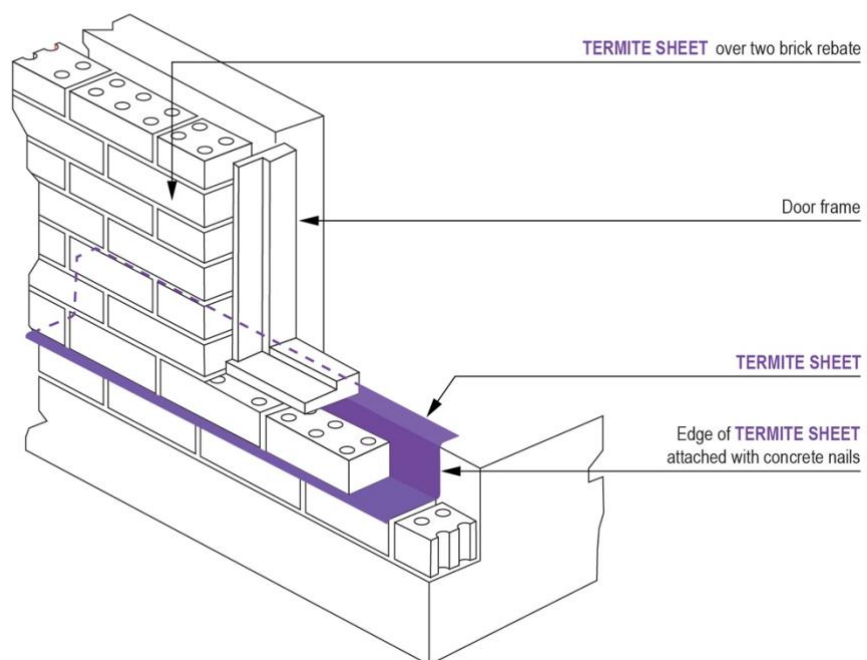

### Suspended Floors

TRITHOR Termite Protection is installed along the curtain walls.

For piers it may optionally be glued beneath a metal ant cap and then placed on the pier. **N.B.** Metal ant caps are not required, this is simply an optional fitting method.

TRITHOR may be installed directly on the piers.

TRITHOR must be cut to fully overlap the walls, piers, engaged piers and/or supports, so that it overhangs by 40 mm. TRITHOR should be nailed and glued in place as appropriate. Position exactly as an ant cap/ shield in Section 5 of AS 3660.1.

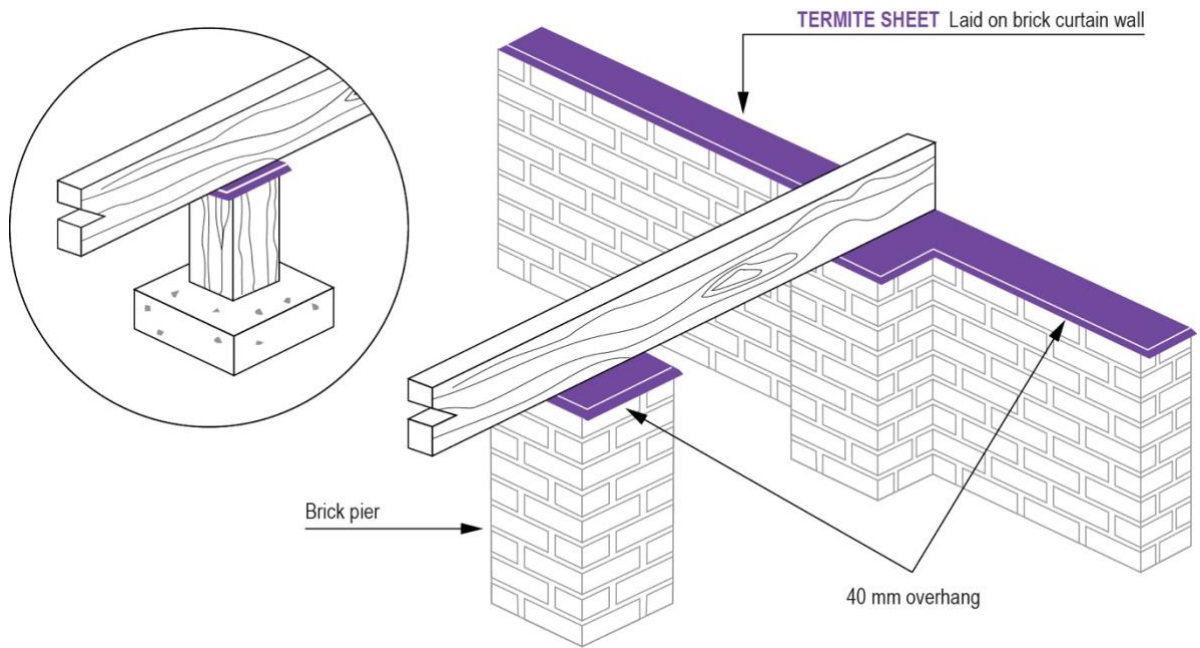

### Demountable Mining Houses

These houses are pre-constructed on their concrete slabs and transported to mining towns. This occurs most commonly in WA. The houses are assembled on site and the two slabs are pushed as

close together as possible. The below design covers this, subject to any overlaps being a minimum of 50 - 75 mm and nail centres being placed at 150 mm. TRITHOR is also glued to the slab. The yellow layer needs to face out.

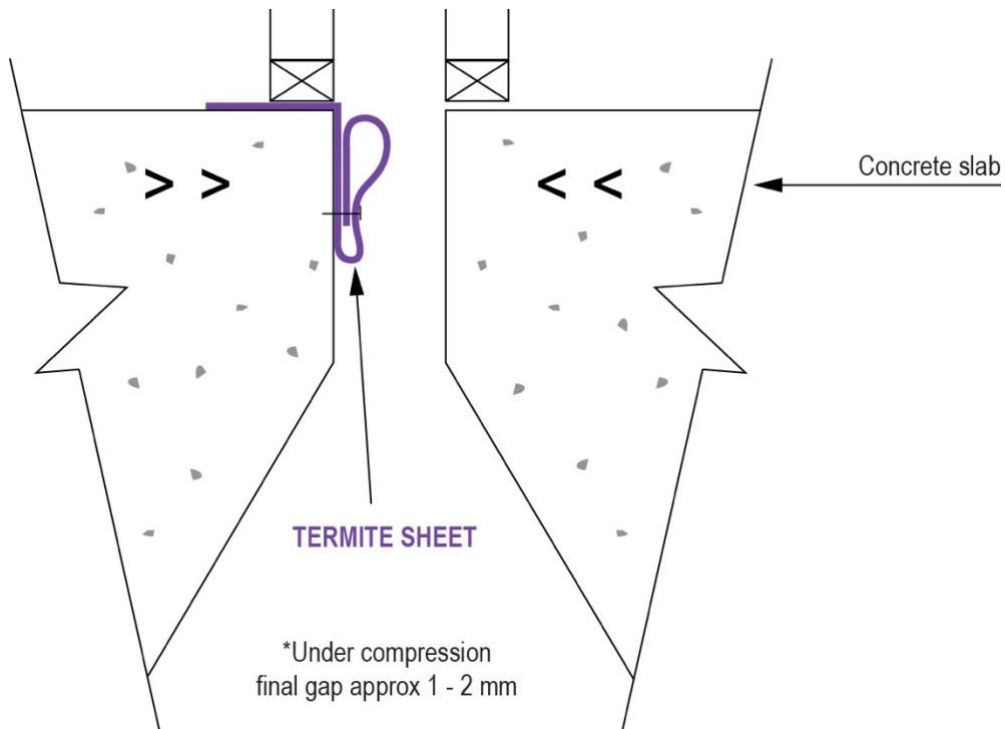

Other Systems

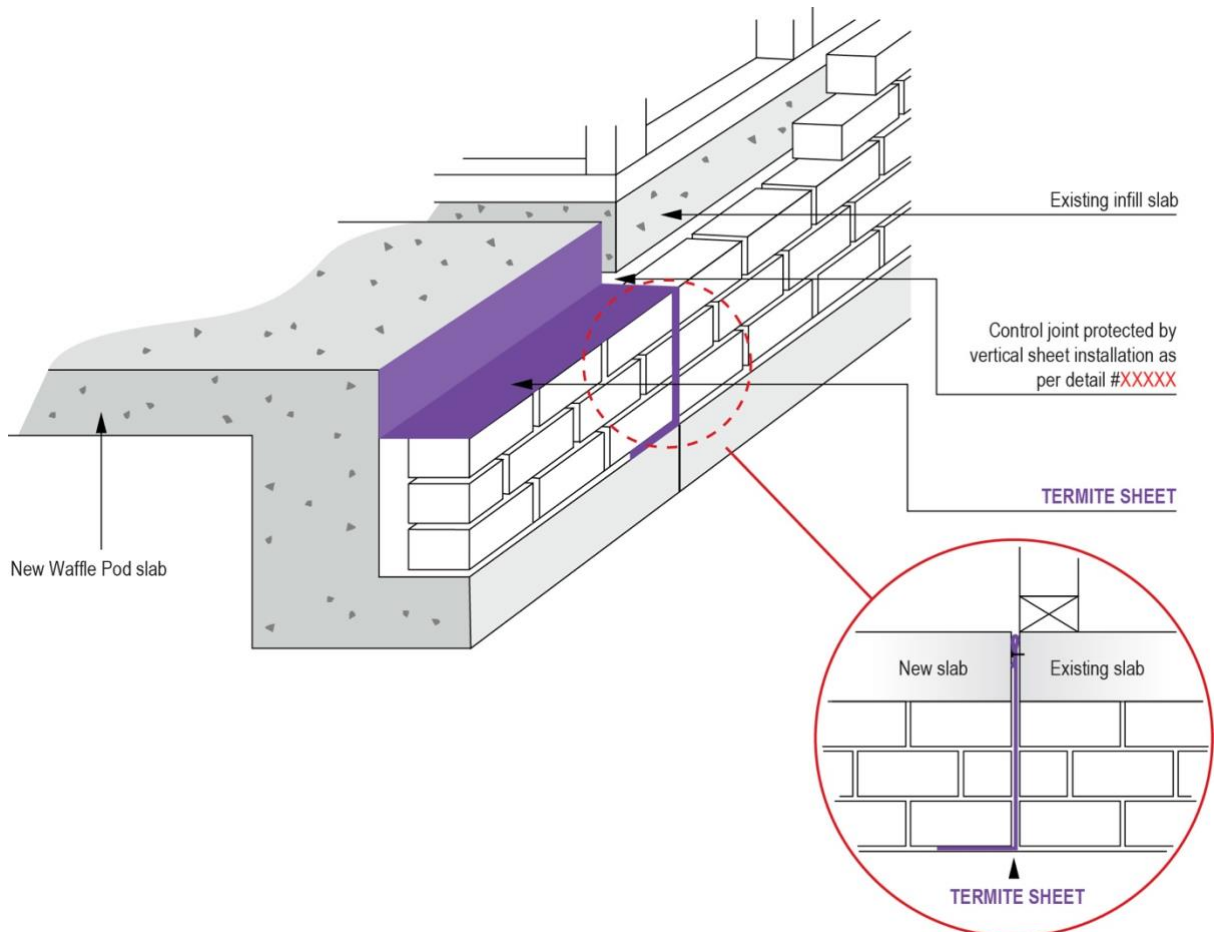
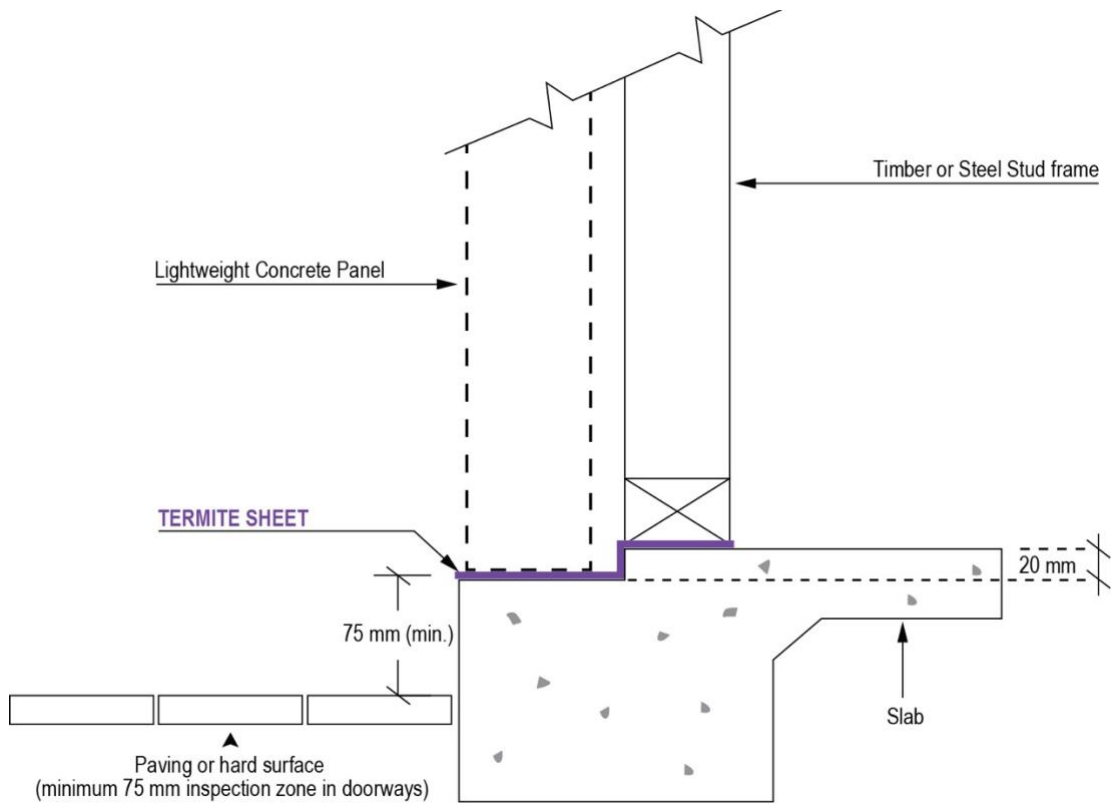

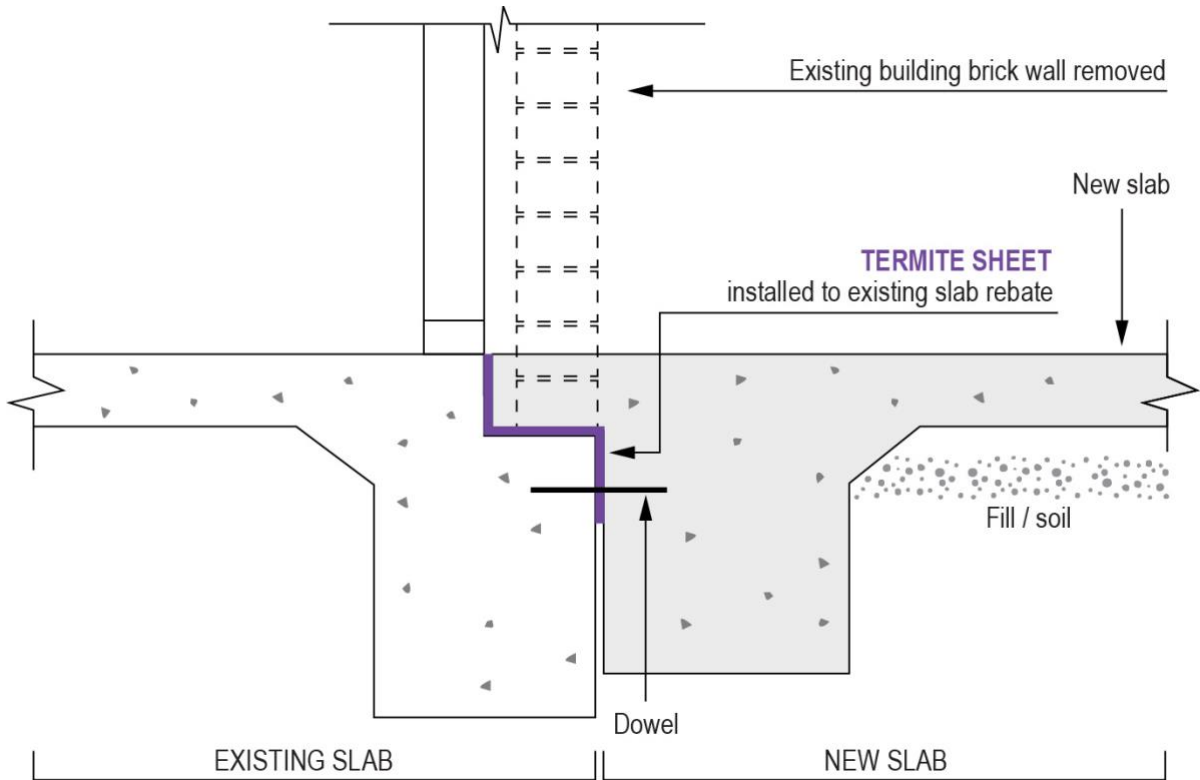

### LIGHTWEIGHT CONCRETE PANEL DETAIL

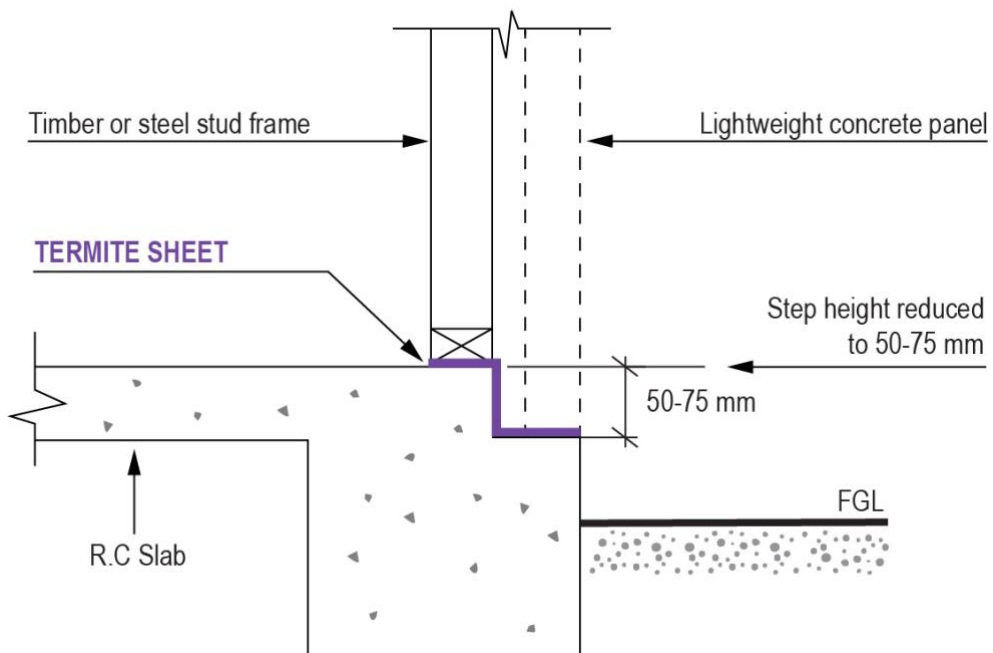

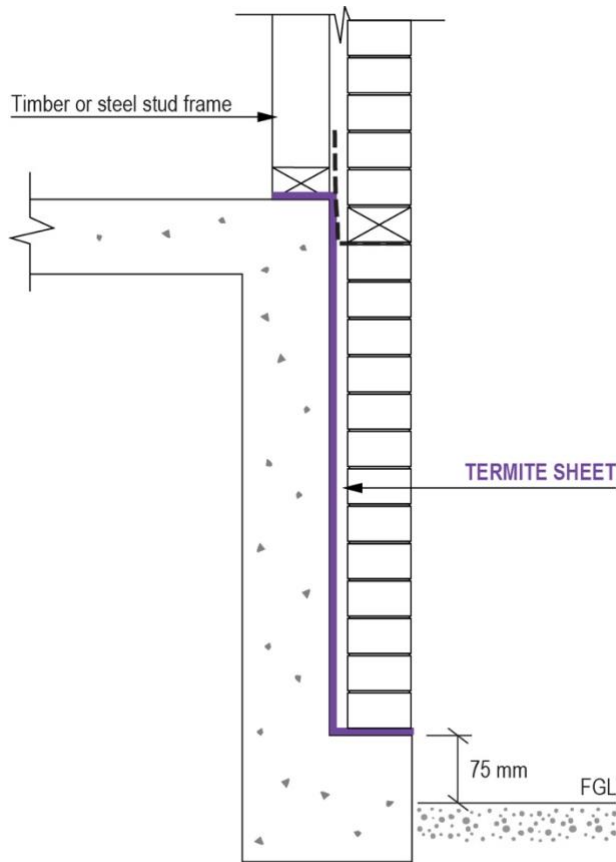

**DEB DROP EDGE BEAM**

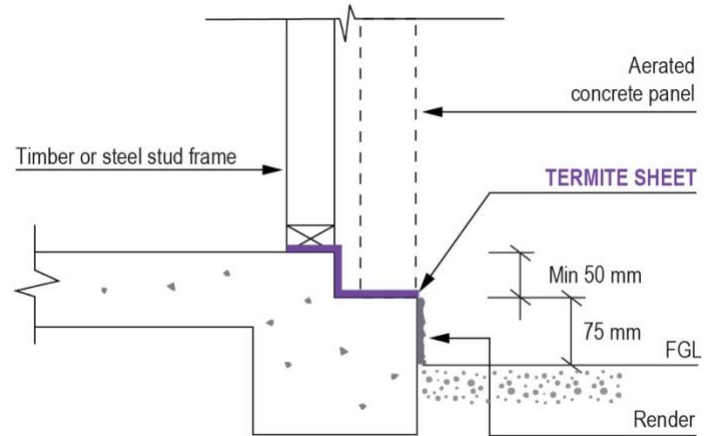

## TERMITE SHEET PROTECTION SYSTEM FC SHEET WEATHERBOARD DETAIL

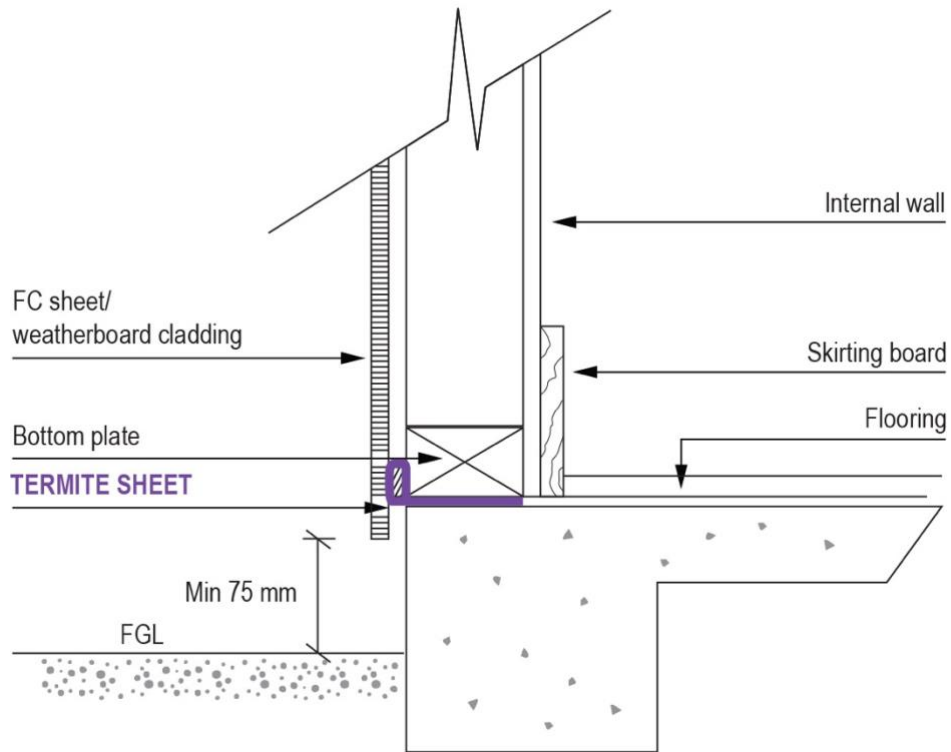

The small piece of wood shown above is a baton that should be placed to allow for airflow up the cavity between the cladding and the wall frame. Many builders do not use this, although it is recommended. The installation will be compliant if it is not placed. The TRITHOR should be sandwiched between the cladding and the concrete and folded with the yellow side in contact with the concrete and cladding.

### GARAGE ATTACHMENTS

OPTION 1



OPTION 2

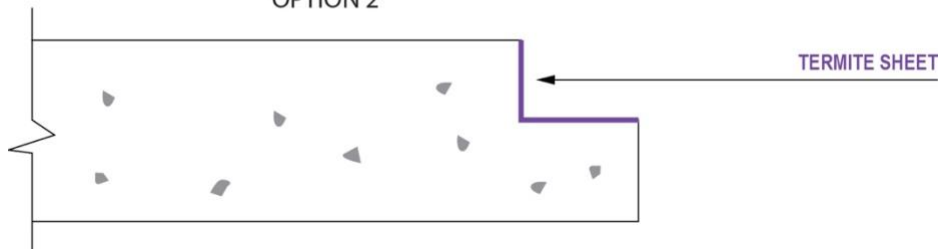

### HIGH PAVING / DRIVEWAY / PATH

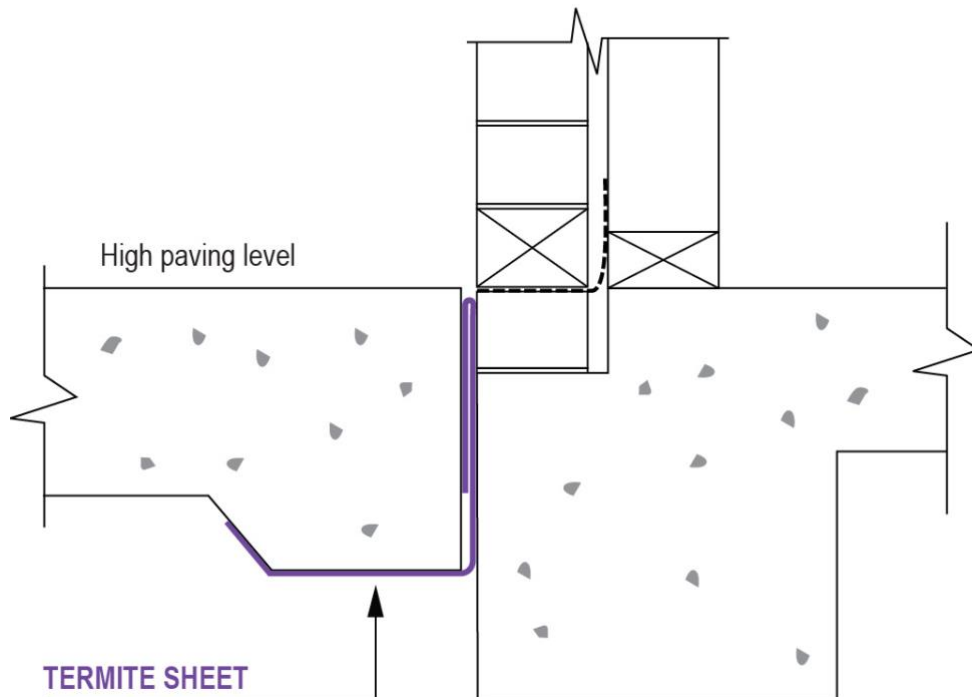



TERMITE SHEET PROTECTING A ONE BRICK REBATE ALFRESCO / PATIO

Sheet extends 25 mm past the edge of the brickwork.  
 Tiles are placed on a sand/ cement bed or by direct fixing.

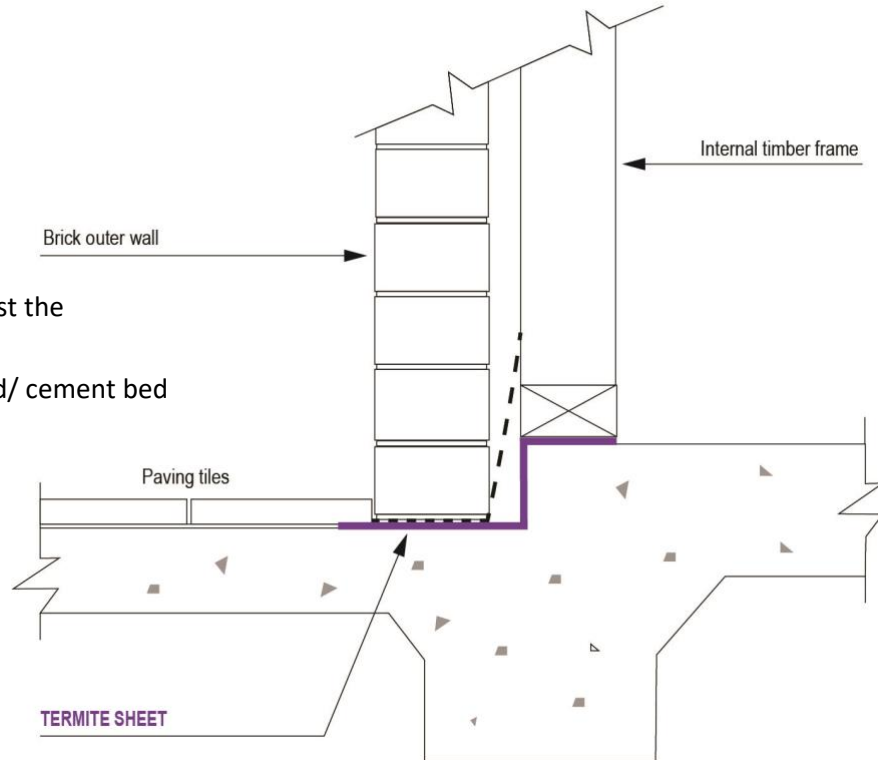

ZERO LOT LINE TERMITE PROTECTION FOR SINGLE LEAF WALLS, USING TERMITE SHEET

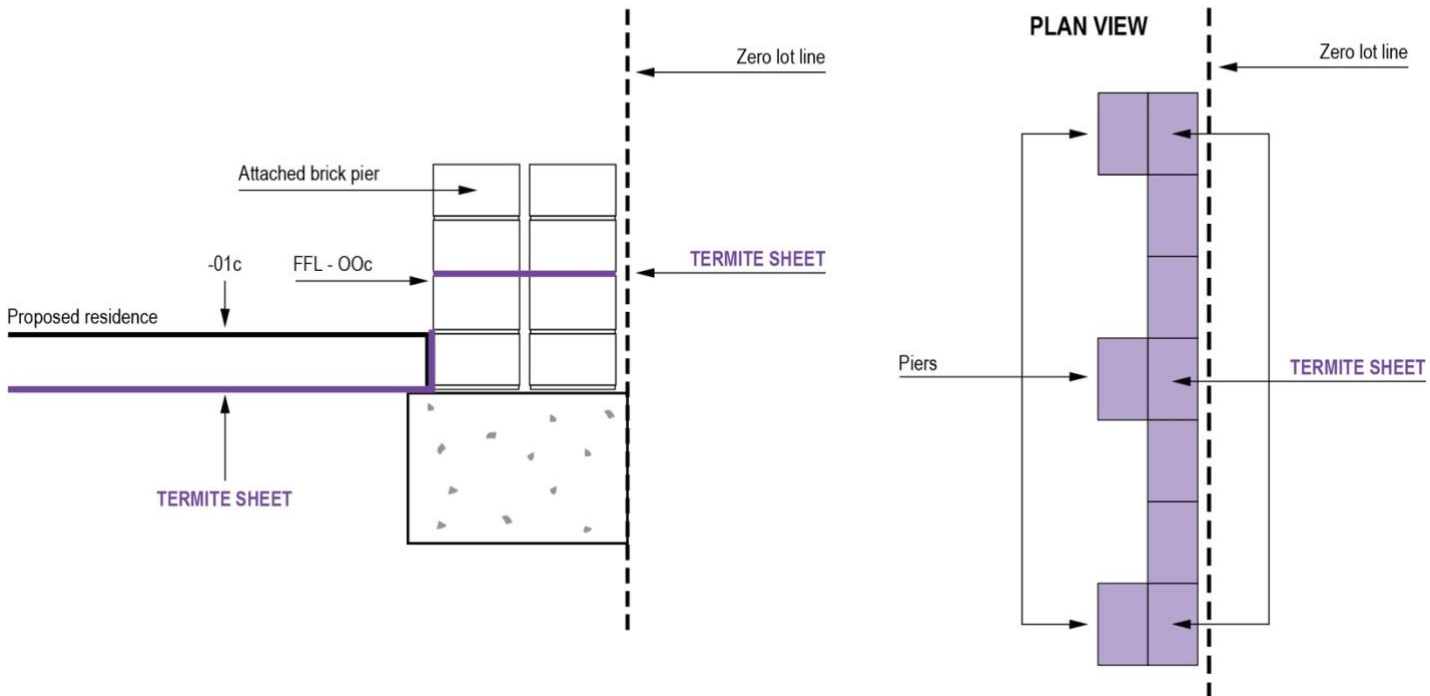

### Isolated Pier/ Column

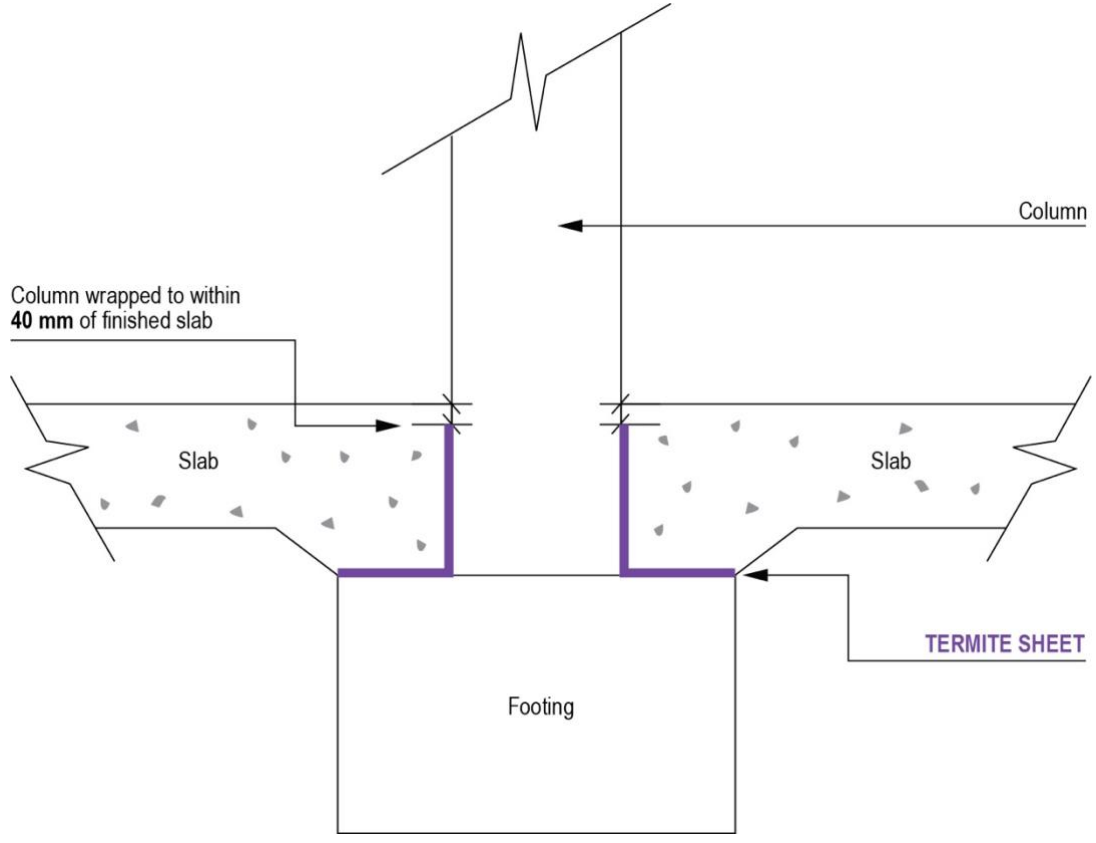

### TERMITE SHEET INSTALLATION TO BRICK PIERS

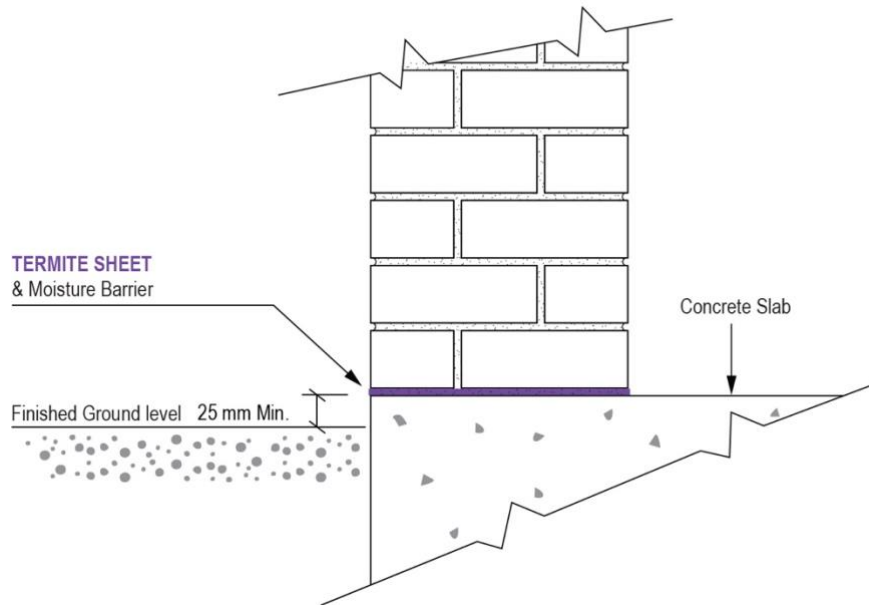

The minimum Inspection Zone in this situation is 25 mm when it abuts a hard surface, otherwise it is 75 mm minimum.

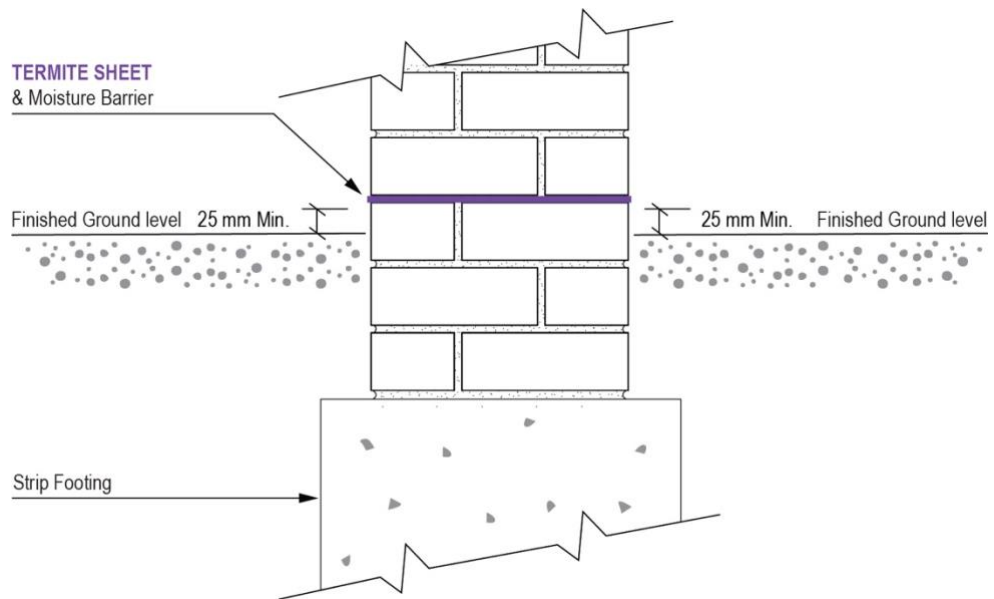

The minimum Inspection Zone in this situation is 25 mm when it abuts a hard surface, otherwise it is 75 mm minimum.

**TERMITE SHEET PERIMETER INSTALLATION 30 MM REBATE**

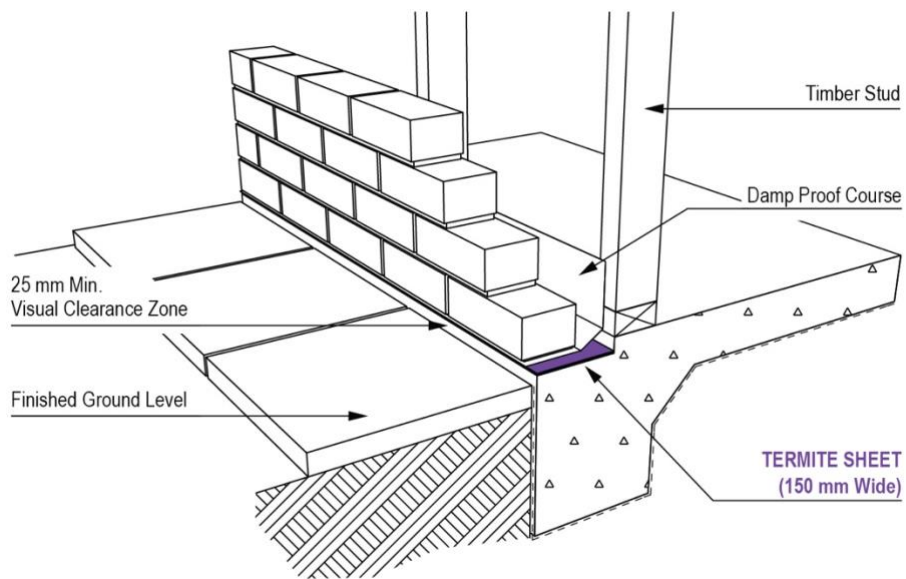
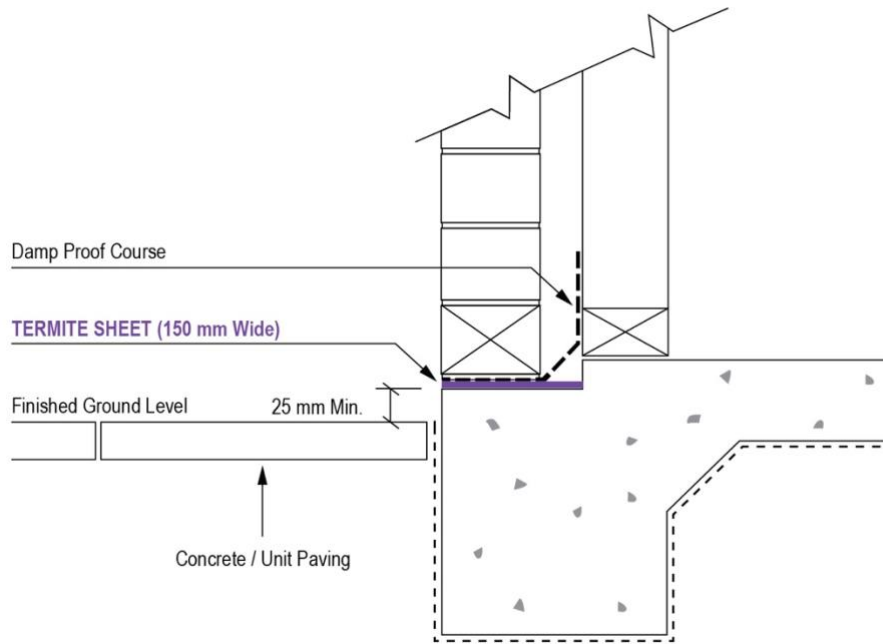

The minimum Inspection Zone in this situation is 25 mm when it abuts a hard surface, otherwise it is 75 mm minimum.

## Essential Equipment

1. TRITHOR Cutting Tool, for cutting TRITHOR.
2. Wiltshire Stay-Sharp Scissors (or similar).
3. 3M 8979 Performance Plus Duct Tape (preferred) or Tessa 4688 Black Cloth Tape for joins.
4. **TRITHOR MAXX Contact Adhesive Spray Termiticide – Aerosol**  
If unavailable:  
3M Multi-purpose Adhesive, 3M Super 77 Spray Adhesive, or 3M Foam Fast 74 Spray Adhesive are acceptable alternatives.  
If these are also unavailable:  
Garrard's Pre-Con 10 Termite Barrier Adhesive.
5. 3M Holdfast 70 Spray Adhesive - Cylinder.
6. Cable Ties (approx. 400 mm) for sealing penetrations.
7. Hammer and concrete nails (20 mm).
8. Ramset Nail Gun (recommended) with 16-20 mm nails and  $\frac{3}{16} \times \frac{3}{4}$  Mudguard Washers through the Ramset Magnetic Washer Dispenser.

9. Tape Measure for accurate measurements.
10. Measure Wheel.

## Paperwork/ Warranty Process

The TRITHOR Approved Installer:

1. Installs TRITHOR Termite Protection.
2. Arranges for placement of AS 3660 Meter Box Stickers in the Electrical Meter Box and/ or inside a cupboard door in the kitchen.
3. Completes the Site Installation Report, with site diagram.
4. Completes the Certificate of Compliance.
5. Completes the Warranty documentation.
6. Provides the builder/ property owner with a Warranty Information Pack consisting of:
  - Termite Information Brochure.
  - Certificate of Installation.
  - Certificate of Compliance.
  - TRITHOR Warranty Activation form.
  - TRITHOR Termite Protection Warranty.