



NOVITHOR™

**THE PESTICIDE FREE
TERMITE PROTECTION SYSTEM**

INSTALLATION MANUAL

 **ECO-FRIENDLY**  **FLEXIBLE**  **TERMITE PROOFING SYSTEM**

**GUARANTEED TERMITE PROTECTION
FOR ANY BUILDING**

* Warranty is renewable each year for 50 years subject to a required annual inspection at your expense.
See Warranty document for complete details.



This Technical Manual details many methods by which NOVITHOR can be installed. However, it is NOT an exhaustive list of methods of installation. Other method of installation may be employed in different building design situations.

The most important perspective with respect to the successful installation of NOVITHOR is to ensure it is installed in accord with the principles of the Australian Standard AS 3660 *Termite management Part 1: New building work* and the National Construction Code (NCC)

Other applications are approved to deal with more complex building designs, and Ensysstex reserves the right to continually update the methods of installation.

Nothing contained in this Manual should be construed as overriding the requirements of the current version of the National Construction Code. The requirements of the NCC ALWAYS take precedence over this Manual.

If there is any doubt, please contact Ensysstex directly.

Similarly, the requirements of the manufacturer of a building component must be followed. This Manual may not always be compliant with the requirements of a specific product or manufacturer.

If there is any doubt, please contact Ensysstex directly.

KEY BENEFITS	4
PESTICIDE FREE - TERMITE PROTECTION SYSTEM.....	4
WHAT IS NOVITHOR?	4
COMPLIANCE.....	5
STATEMENT OF QUALITY.....	5
ABOUT TERMITES	6
INSTALLATION - GENERAL	7
AUTHORISED INSTALLERS	7
GENERAL PROCEDURES	7
BUILDER'S RESPONSIBILITY	7
TERMITE INSPECTIONS.....	7
INSPECTION ZONES	7
ANNUAL INSPECTIONS.....	7
NOVITHOR TERMITE PROOF CEMENTITIOUS PARGE	8
BENEFITS	8
APPLICATION DIRECTIONS.....	10
.....	25
NOVITHOR TERMITE PROOFING RESIN	28
BENEFITS	28
APPLICATION DIRECTIONS.....	28
INSTALLATION VIDEO LINK	28
NOVITHOR TERMITE PROOF FLEX-GEL	31
BENEFITS	31
APPLICATION DIRECTIONS.....	31
SPECIAL INSTALLATION DETAILS.....	46
NOVITHOR TERMITE PROOF COLLARS.....	53
INSTALLATION.....	53
ESSENTIAL EQUIPMENT.....	56
ESSENTIAL INSTALLATION EQUIPMENT.....	56
ESSENTIAL SAFETY EQUIPMENT	56

™ Trademarks of Ensystem, Inc. used by licence to Ensystem Australasia Pty. Ltd.

Key Benefits

Pesticide Free - Termite Protection System

Tough. NOVITHOR Termite Protection System is exceptionally tough and will not be damaged by normal building work practices.

No Registration Requirements with the Australian Pesticides and Veterinary Medicines Authority (APVMA).

Durable for 50 years.

BCA Compliant. NOVITHOR Termite Protection System complies with the relevant requirements of the Building Code of Australia.

Environmentally friendly. Pesticide free.

User-friendly and flexible to install and doesn't impinge on any other trades.

Suits all building designs.

Manufacturer's Warranty.

What is NOVITHOR?

NOVITHOR Termite Protection System consists of;

1. NOVITHOR Termite Proof Cementitious Parge.
2. NOVITHOR Termite Proofing Resin.
3. NOVITHOR Termite Proof Flexi-Gel.
4. NOVITHOR Termite Proof Collars.

NOVITHOR Termite Protection System is a flexible termite protection system which can be used as part of a complete termite protection system in association with other approved systems.

It is particularly used with a concrete slab, poured, and cured in accord with the requirements of AS 2870: *Residential slabs and footings - Construction* and AS 3600: *Concrete structures*.

The slab in this case forms part of the termite protection system with NOVITHOR Termite Protection System protecting the high-risk termite penetration areas. It is applied in a range of widths to suit the particular building design.

It is also used for bearer and joist constructions and piers.

Compliance

NOVITHOR Termite Protection System is approved as an alternative solution in accord with the Building Code of Australia (BCA). The approved Assessment Method is that independent scientific evidence has been produced to prove that the NOVITHOR Termite Protection System meets the Performance Requirements of the Australian Standards AS 3660 Series - Termite management.

Evidence of this is contained within reports provided in **CSIRO Entomology, CSIRO Engineering, Agrisearch and Newcastle University Reports** and through the Australian Building Codes Board **CodeMark Accreditation**.



These evaluations included documentary evidence produced by CSIRO Entomology, CSIRO Engineering Newcastle University and Agrisearch Laboratories. These reports prove conclusively that NOVITHOR Termite Protection System may be used in accord with, and meet, the requirements of:

AS 3660.1.2014 Termite Management - Part 1: New building work;

AS 3660.3.2014 Termite Management – Part 3: Assessment criteria for termite management systems;

AS 2904.19957 Damp Proof Course

AS 3700.2011 Masonry Structures

AS 2870.2011 Residential slabs and footings - Construction

AS 3600-2018 Concrete structures

Independent trials conducted in accordance with the requirements of the Australian Standard AS 3660.3 *Termite management Part 3 Assessment criteria for termite management systems*; and other tests show that NOVITHOR Termite Protection System should remain as an effective termite measure for 50 years.

NOVITHOR Termite Protection System meets the performance criteria of section 1 Clause 1.3 of AS 3660 *Termite management Part 1, New building work* in accordance to AS 3660 *Termite management Part 3 Assessment criteria for termite management systems*.

NOVITHOR Termite Protection System also meets the Deemed-to-Satisfy Provision(s) Volume 1 BCA 2022: B1D4(i) Termite Risk Management and Volume 2 BCA 2022: H1D3(3) Termite Management Systems.

Statement of Quality

The NOVITHOR Termite Protection System, has been designed to achieve a service life of 50 years during which period the NOVITHOR Termite Protection System, including its constituent components, is expected to maintain efficacy and function as a physical termite protection system in accordance with AS 3660.1.

The NOVITHOR Termite Protection System has been designed in accordance with a quality management system that incorporates a set of rules for the design, manufacture, installation, and maintenance of all elements of the system;

The components used in the manufacture of the NOVITHOR Termite Protection System have been selected for their intended purpose and are expected to operate in accordance with their specification for the duration of the design life of the NOVITHOR Termite Protection System.

About Termites

No property in mainland Australia is safe from termites. Termites are the cause of the greatest economic losses of timber in service in Australia. Independent data compiled by State Forests indicates that 1 in every 5 Australian homes is attacked by termites at some stage in its life. Australia's subterranean termite species (white ants) are the most destructive timber pests in the world. In fact, it can take "as little as 3 months for a termite colony to severely damage the timber in a home".

How Termites Attack Homes. The most destructive species live in large underground nests containing more than a million timber destroying insects. The problem arises when a nest matures near a home. Homes tend to provide natural shelter and food for the termites. The gallery system of a single colony may exploit food sources over as much as one hectare, with individual galleries extending up to 75 metres to enter homes, where there is a smorgasbord of timber to feast upon. Even concrete slabs do not act as a barrier; termites can penetrate through cracks in the slab to gain access. They also build mud tubes around the slab to gain access to above ground timbers.

Termite Damage. Once in contact with timber, termites excavate it, often leaving only a thin veneer on the outside. If left undiscovered, the economically important species can cause many thousands of dollars damage and cost two to five thousand dollars (or more) to treat.

Subterranean Termite Ecology. Termites are social insects usually living in large underground nests. Nests may be in trees or in rare instances they may be in above ground areas within the property. They tunnel underground to enter the building and then remain hidden within the timber making it difficult to locate their presence. Where timbers are concealed, as in most modern homes, it makes it more difficult to locate their presence. Especially if gardens have been built up around the home and termite protection systems are either not in place or poorly maintained.

There are about 3,000 species of termites found in the world with about 300 species native to Australia. All termites eat some form of plant cellulose. Most termites simply eat humus in the soil, or grass and leaves. Very few eat wood, and only a small number of these eat sound wood (i.e., wood that has not been decayed by fungus). Some 20 or more species cause serious economic loss to Australian homes.

Termite Biology. Termites or "white ants" are social insects that work and live together in groups called colonies. Each colony contains several castes which differ in body shape, behaviour and tasks performed.



The **king and queen** mate and control the entire colony. In most species that causes economic loss to Australian homes, the queen becomes physogastric. This means she has a grossly enlarged abdomen for the purpose of laying millions of eggs. She is essentially an egg laying machine. These eggs hatch into the nymphal stage and through a series of moults develop into one of the adult castes.

The **worker** caste has the largest number of individuals within the colony and is responsible for building the nest, tending eggs and young termites, gathering food, and feeding those castes that are unable to feed themselves. Worker termites are wingless, blind and do not reproduce. Workers perform almost all the tasks in the colony except for defence and reproduction.

The **soldier** caste can be distinguished from other castes by the head. The head of the soldier caste is large, dark and has either mandibles or a 'nasute' (pointed) protuberance. Soldier termites defend the colony against predators such as ants and are also unable to reproduce.



The **winged reproductive** caste are the potential future kings and queens of new colonies. This caste has eyes and wings, and usually leaves the parent colony in large swarms. They do not fly very far before shedding their wings.

Installation - General

Authorised Installers

For CodeMark installations, NOVITHOR Termite Protection System may only be installed by NOVITHOR Authorised Installers who have been trained by Ensystex to help ensure installations are done correctly and that systems comply with the requirements of the Australian Standard Series AS 3660 *Termite management* and the Australian Environmental Pest Managers Association *AEPMA Industry Code of Best Practice for Termite Management during Constructions*.

NOVITHOR Authorised Installers must demonstrate their understanding of, and compliance with, the procedures and requirements of this Installation Manual. Any breach of, or deviation from, the required procedures may result in the termination of their Authorisation. Only appropriately trained and licensed pest management professionals can qualify as NOVITHOR Termite Security Authorised Installers. The NOVITHOR Termite Protection System Authorised Installer must nominate trained installers who will be operating under their Licence.

Licenses may be cancelled, and supply stopped to any company that acts fraudulently or demonstrates consistently poor-quality workmanship.

General Procedures

It is the responsibility of the NOVITHOR Termite Protection System Authorised Installer to liaise with the Builder and ensure that the installation procedures are correctly performed so that the completed NOVITHOR Termite Protection System can be certified by the NOVITHOR Termite Protection System Authorised Installer to comply with the Ensystex Warranty Program.

Builder's Responsibility

Builders must ensure that:

1. The under-slab soil substrate is levelled.
2. All service pipe penetrations are installed in their final position.
3. they are aware of the placement requirements for NOVITHOR Termite Protection System.
4. once installed, NOVITHOR Termite Protection System must not be moved without consulting with the NOVITHOR Termite Protection System Authorised Installer.

5. They inform the NOVITHOR Termite Protection System Authorised Installer of any damage to, disturbance of, or misalignment of the NOVITHOR Termite Protection System prior to the pouring of the concrete slab.

Termite Inspections

Inspection Zones

The Australian Standard AS 3660.1 Termite management – New building work, refers to a 75 mm inspection zone between the exposed edge of a termite protection system in the outer wall of a building and the grade level beneath.

The purpose of this inspection zone is to ensure that sufficient un-occluded surface exists to allow easy identification of termite mud-tubes up the outer wall of the structure during the inspection process. It was decided at the time by the Standards Committee that a distance of 75 mm (the depth of one standard building brick) would allow for changing grade levels due to gardening activities in adjacent soil, the depth of growing grass and so on, while still leaving sufficient un-occluded surface to allow for efficient inspection.

Where the grade is fixed and unchanging against the wall surface, such as in the case of concrete or paved pathways, patios, and driveways, this inspection zone may be reduced. This is particularly important where step-downs in doorways and windows occur.

With installations of NOVITHOR Termite Protection System, where hard surfaces such as concrete or paving exist, a minimum distance of 25 mm should exist between the outer exposed edge of the termite protection system and the top surface of the concrete or paving. This distance is adequate to allow for identification of termite mud-tubes by those trained to do so, or by observant property owners.

Annual Inspections

All termite management systems require at least an annual inspection by a professional timber pest inspector in accord with the requirements of the Australian Standard Series AS 3660 *Termite management*. These inspections are integral to good termite management.

For details of appropriate inspection standards see Section 12.1 of the *AEPMA Industry Code of Best Practice for Termite Management*.

NOVITHOR Termite Proof Cementitious Parge

Benefits

1. Has the unique ability to become part of the matrix of masonry surfaces.
2. Does not leach through products when over coating is required e.g., water proofing membranes, painting systems, cement renders, etc.
3. Has high bond strength to a wide range of building products.
4. Has an M4 mortar rating (high strength grout classification).
5. Does not contain any termiticides or poisons.
6. Mixed on site and applied in a two-coat application by soft broom, brush, or trowel.
7. Cost effective termite protection for large surface areas.

CSIRO Approved for Damp-proofing

NOVITHOR Termite Proof Cementitious Parge has been tested in compliance with AS/NZS 4347.1:1995 Australian/New Zealand Standard: Damp-proof courses and flashings. See Test Report 4591A from CSIRO Materials Science & Engineering, 37 Graham Road, Highett, Victoria 3190.

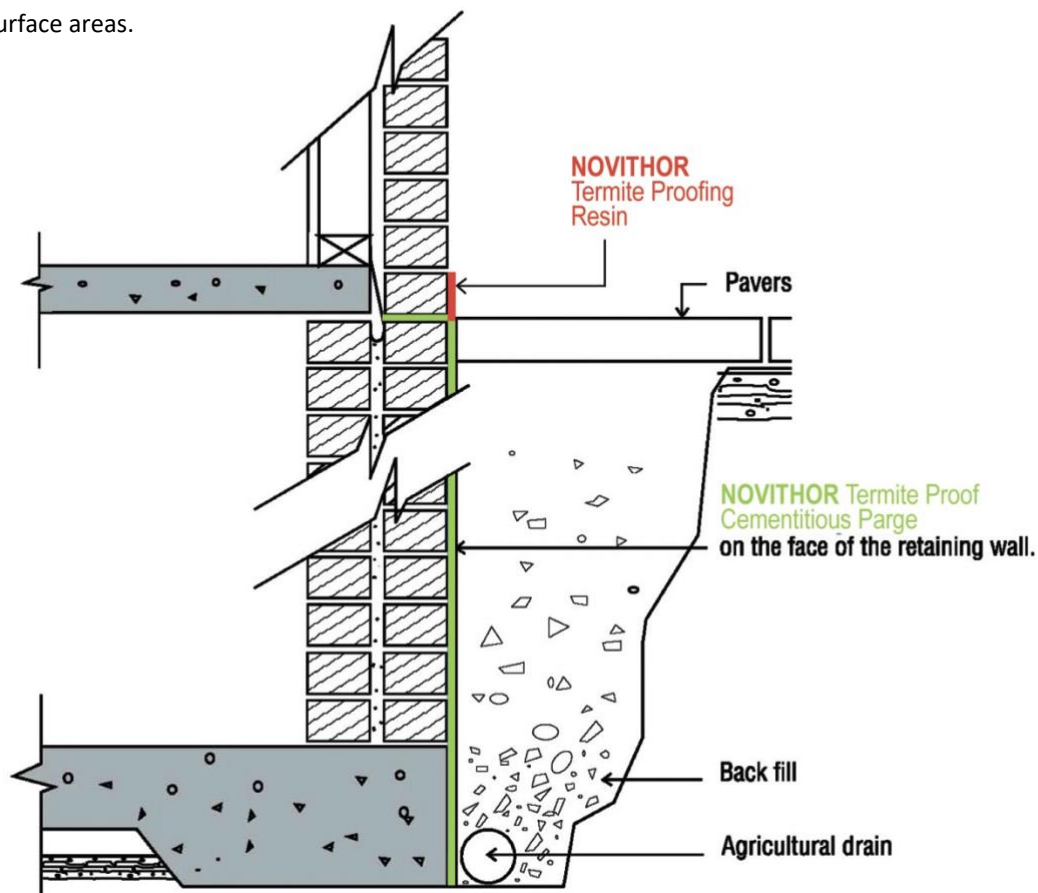

TERMITE PROTECTION SYSTEM FOR EXTERIOR RETAINING WALL AND FACE BRICKWORK

Description

NOVITHOR Termite Proof Cementitious Parge is a ready-to-use pumpable, natural aggregate, general purpose grout which undergoes controlled expansion in the plastic state. It is a Class 'A' grout as defined by SAA MP20 – Part 3, 1977.

There are two components to NOVITHOR Termite Proof Cementitious Parge, NOVITHOR TPC Powder and NOVITHOR TPC Liquid. They are generally mixed at a rate of 4 parts NOVITHOR TPC Powder to one-part NOVITHOR TPC Liquid.

NOVITHOR Termite Proof Cementitious Parge is applied to a minimum thickness of 4 mm. Where the product is applied as a coating this will require a two-coat application. When applied into a recess such as a penetration or construction joint the 4 mm depth can usually be achieved with a single application.

Uses

- As a physical termite protection system and damp-proof course;
- As a perimeter termite protection system in knock out block work.
- As a perimeter termite protection system in cavity brick construction.
- When applied to brick or core filled block work used in retaining walls.
- As a continuous termite protection system in bearer and joist construction.
- Applied to Hebel or other panelling systems.
- As a repair mortar for concrete repairs.
- As a high strength grout in tilt panel construction.
- On the top of reinforced concrete slabs around pipe penetrations.
- Over concrete rebates as a damp-proof barrier.
- As a mortar or render.

Recommended For

All general-purpose grouting operations with clearance of 12-15 mm or more including:

- Column bases, in-fill grout for cavity block walls.
- In caulking of joints and pipes.
- Between pre-cast panels and other joints where total load-bearing is not required.
- Underpinning where a grout similar in appearance to concrete is required.

Features

- Low liquid/cement ratio reduces drying shrinkage and increases durability.
- May be damp packed without slumping.
- Complete void filling resulting from controlled fluid-phase expansion.
- Non staining cement, similar in appearance to plain concrete.
- No added chlorides.

Performance Data

The strength of the cement is often the determining factor in deciding when loads can be put on structural members or machinery that has been grouted. The strength of the cement is dependent on the amount of NOVITHOR TPC Liquid added, temperature (ambient and grout), curing and age of the hardened cement.

Typical compressive strength of NOVITHOR Termite Proof Cementitious Parge in place at 20oC is:

Compressive Strength (MPa):

Age	Consistency		
	Damp	Plastic	Flowable
1 day	30	22	18
3 days	50	39	36
7 days	55	44	41
28	66	55	50

(Tested in accordance with AS 2073-Part 10, 1977 using 5

0 mm cubes, moist cured and restrained during setting)

Flexural Strength (MPa):

Age	Consistency		
	Damp	Plastic	Flowable
7 days	10	7-5	7
28	11	9.5	9

Tested as 160 mm x 40 mm x 40 mm prisms.

Setting Times and Bleed:

Temp. @ 23°C	Consistency		
	Damp	Plastic	Flowable
Initial Set	3:30	5:15	6:05
Final Set	4:10	6:45	7:45
Bleed (%)	0	0	0.6

Note: The data shown is based on controlled laboratory tests. Reasonable variations from the results can be expected in practice.

Application Directions

Preparation

The foundations should be clean, well roughened, and pre-saturated with water. Eliminate external sources of vibration until the grout hardens.

NOVITHOR TPC Liquid

20 kg of NOVITHOR TPC Powder mixed with 5 litres of NOVITHOR TPC Liquid yields 11.0 litres (0.011m³).

The actual amount of NOVITHOR TPC Liquid used depends on the desired consistency for the job and temperature (both ambient and grout). For any given consistency more liquid will be required at high temperatures and less at low temperatures. As a guide, 20 kg of NOVITHOR TPC Powder mixed at 20° C requires the following amount of liquid to achieve the consistency indicated:

Consistency	Litres per 20 kg bag
Damp Packed	2.4
Plastic	3.75
Flowable	5.0

Damp packed is used for tilt slab panel applications.

Plastic is used for repairing holes in mortar joints, and concrete repairs.

Flowable is used for retaining walls and pipe penetrations.

A little bit of water may be added if the mixture needs to be made a little more flowable, e.g., to reactivate the product if it is starting to dry out.

Note: DO NOT USE NOVITHOR TPC LIQUID IN AN AMOUNT OR AT A TEMPERATURE THAT WILL CAUSE THE MIXED CEMENTITIOUS PARGE TO BLEED EXCESSIVELY OR SEPARATE.

Mixing

For large quantities use a paddle type mortar mixer.

For smaller quantities, mix in a 20-25 litre bucket using a heavy-duty electric drill fitted with a helical paddle bit (Jiffy).

When using a mortar mixer, add about 70% of the required mixing liquid before adding any NOVITHOR TPC Powder. Add only as much NOVITHOR TPC Liquid as necessary to provide required consistency. Too much

NOVITHOR TPC Liquid may adversely affect expansion characteristics and strength development. Mix until parge appears homogeneous, about 2 minutes.

When using a helical mixer, add all the required NOVITHOR TPC Liquid before adding any NOVITHOR TPC Powder. Mix for 1 - 2 minutes. Do not use NOVITHOR TPC Powder from damaged containers.

Placement

Place NOVITHOR Termite Proof Cementitious Parge within 30 minutes of mixing. Place by hand and ram (damp pack) or rod into place (plastic).

NOVITHOR Termite Proof Cementitious Parge may be placed at a flowable consistency by pouring from one side only into a formed header box. Avoid entrapping air.

To facilitate NOVITHOR Termite Proof Cementitious Parge movement, gently strap or rod the NOVITHOR Termite Proof Cementitious Parge. **A minimum thickness of 4mm is required.**

Shelf Life

NOVITHOR TPC Powder has a shelf life of approximately 24 months when stored in a cool dry environment. The expiry date is printed on the container.

Precautions

The Cementitious material in NOVITHOR TPC Powder may cause irritation, avoid contact with eyes and prolonged contact with skin. In case of contact with eyes, immediately flush with water for at least 15 minutes. Call a physician. Wash skin thoroughly after handling product. Keep product out of reach of children.

Read the MSDS before use.

Mixing on site



Figure 2 Mixing on site

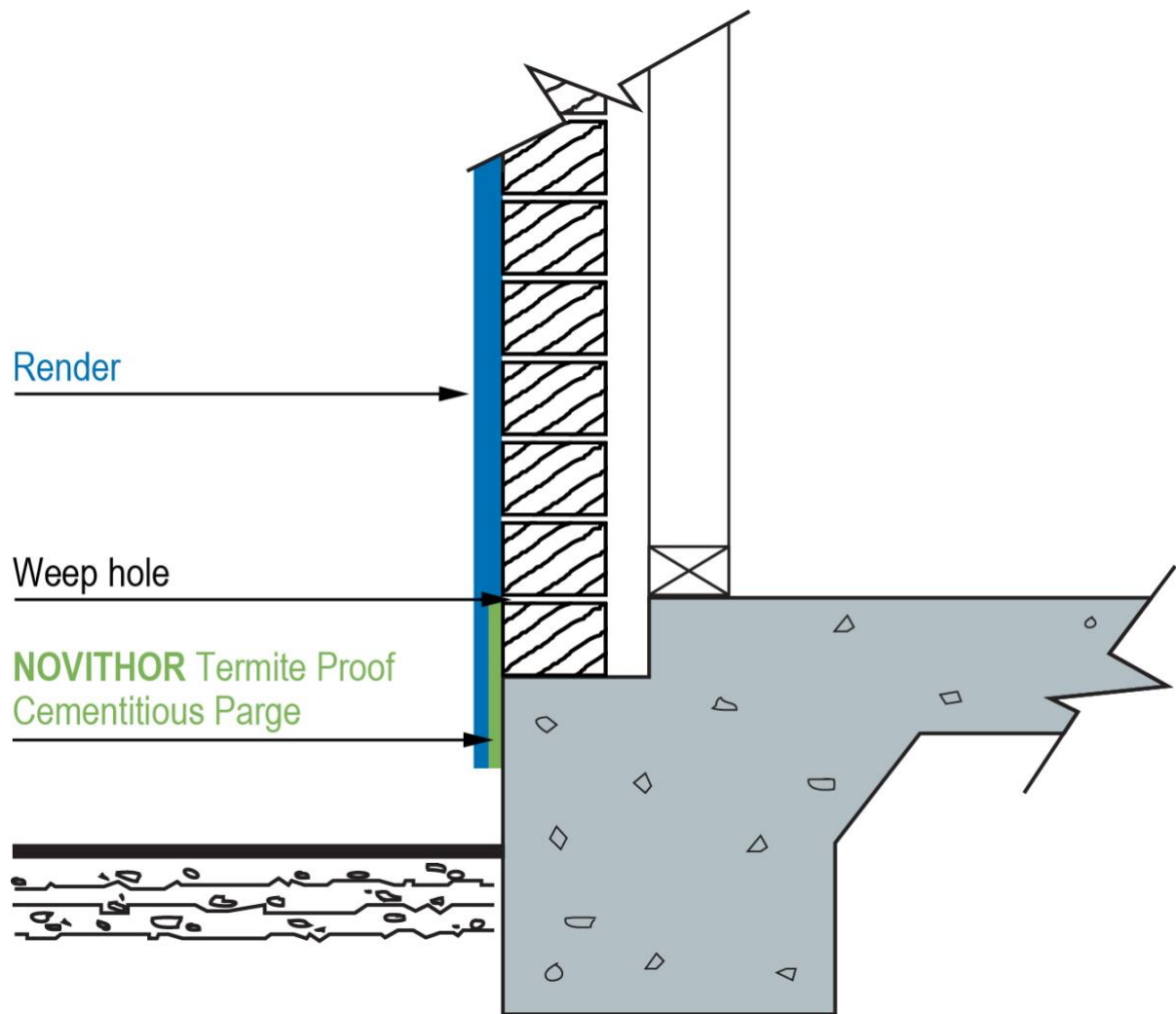

A strike line is essential for all renders in accord with the requirements of the NCC Building Code of Australia.

Application to Retaining Wall

1st Coat



Figure 3 Ensure block work has been wet down with water before applying the first coat of NOVITHOR Cementitious Parge using a soft broom. (This will ensure product penetration and adhesion to block work.)



Figure 4 First coat is left to dry.

2nd Coat



Figure 5 Second coat applied after the first coat application is touch dry. The final minimum thickness must be 4 mm.

TERMITE PROTECTION SYSTEM FOR RETAINING WALL

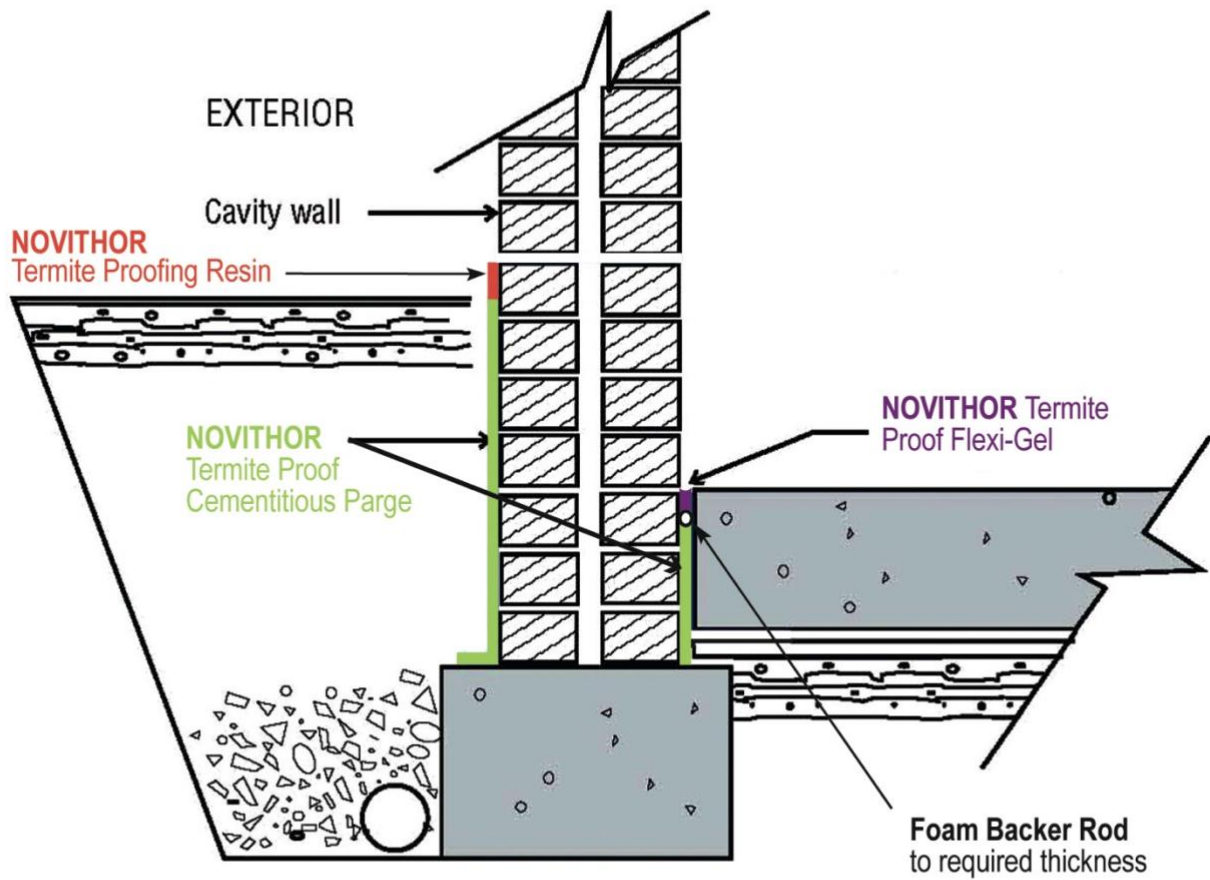

Figure 6

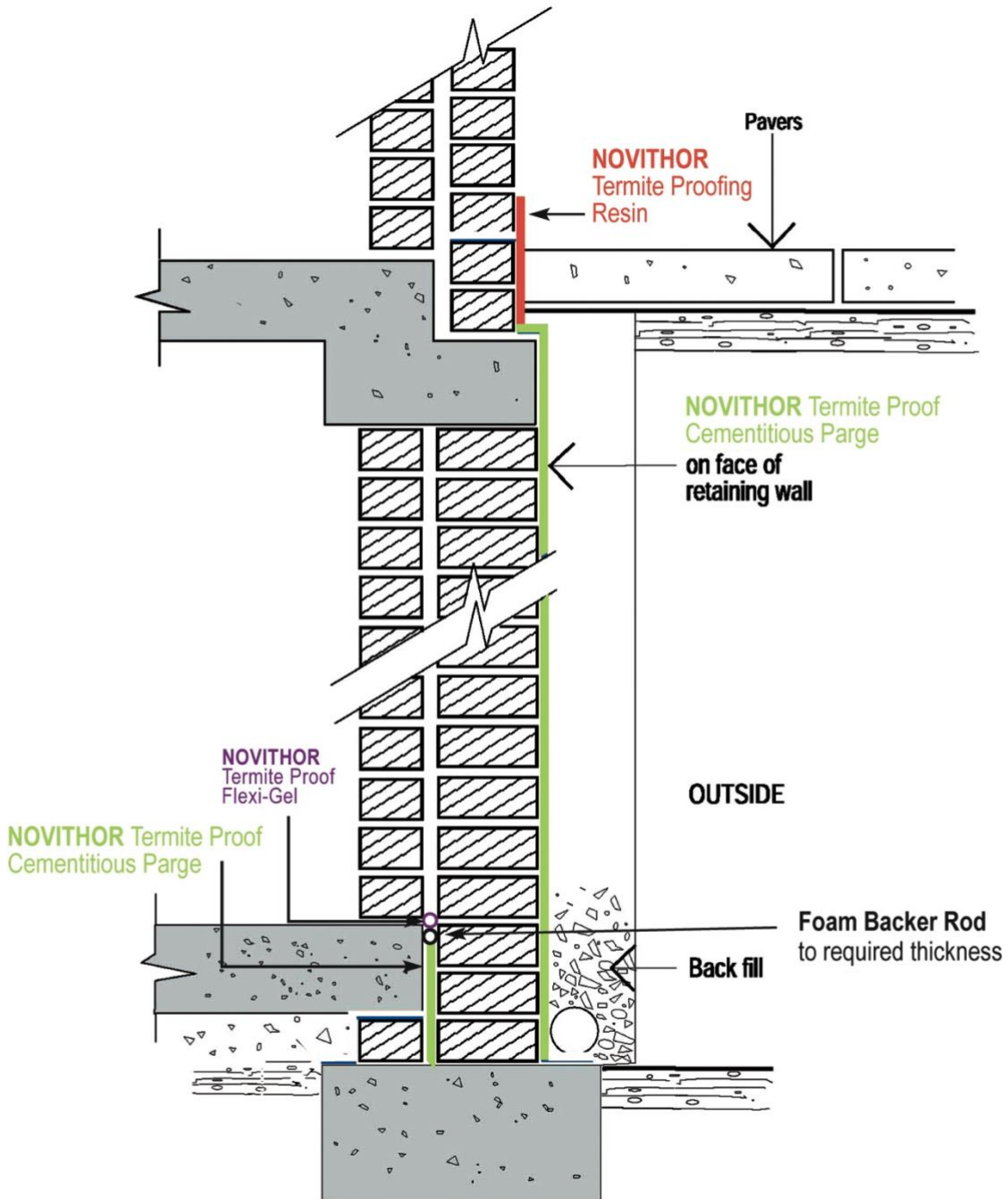

Figure 7

TERMITE PROTECTION SYSTEM FOR RETAINING WALL

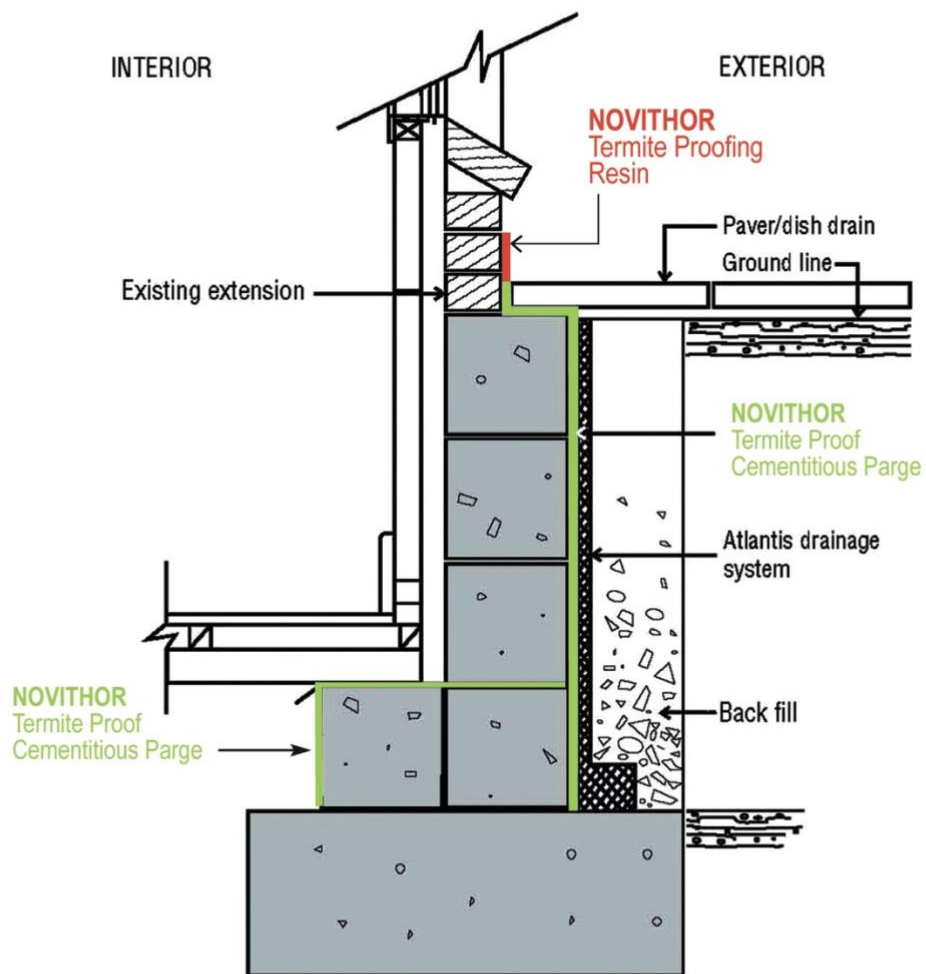

Figure 8

Construction Joints & Pipe Penetrations



Figure 9 NOVITHOR Cementitious Parge over cold joint in RC retaining wall.



Figure 12 NOVITHOR Cementitious Parge over cold joint between old and new concrete and around pipe penetrations.



Figure 10 NOVITHOR Cementitious Parge over cold joint between concrete slab and footing plinth.

PENETRATION

ON SLAB

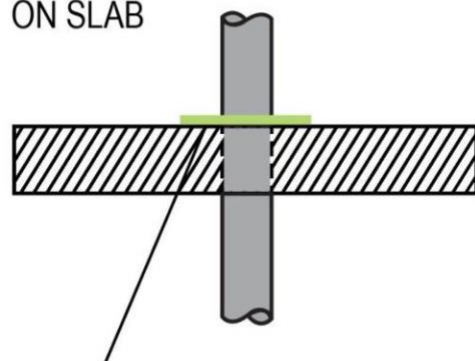

NOVITHOR TERMITE PROOF CEMENTITIOUS PARGE PENETRATION BARRIER TO TOP OF CONCRETE SLAB

Figure 13



Figure 11 NOVITHOR Cementitious Parge over cold joint between concrete slab and concrete block. Refer page 27.

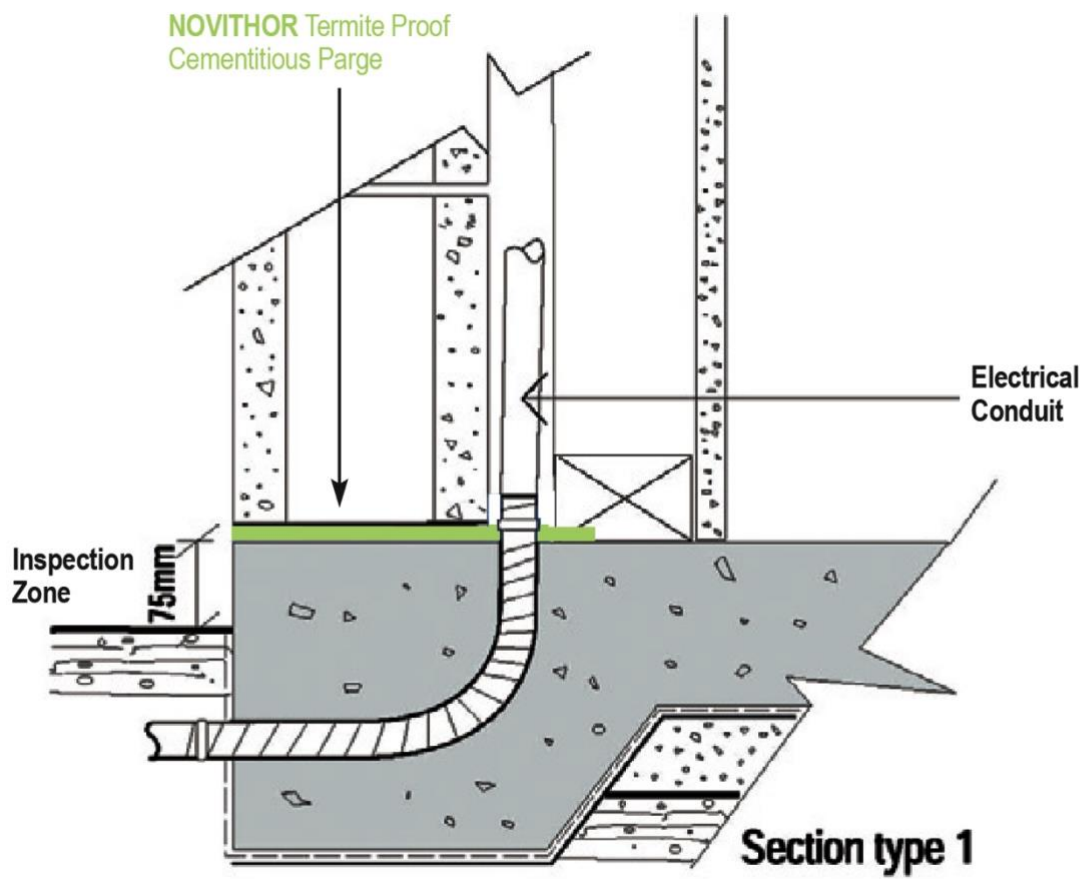

Figure 14



Figure 15 Using a rotary hammer drill with a flat chisel bit, chip out a recess in the slab approx. 5 mm deep.



Figure 18 Wipe pipe and surrounding slab clean using a wet rag.



Figure 16 Clean any excess concrete from the edge of the pipe using coarse sandpaper.



Figure 19 mix TPC Powder and TPC Liquid to a wet consistency to flow into the recess around the pipe.



Figure 17 Brush dirt and loose concrete from the base of the pipe and surrounding slab area.



Figure 20 Apply Parge to base of pipe with a soft brush & ensure recess is full with no gaps and extends 50 mm.



Figure 20A Completed pipe

Alternatively, where it is expected that the pipes will be cut by later trades, the following method may be employed. In this case the NOVITHOR Installer cuts the pipes prior to applying the NOVITHOR Termite Protection. This ensures the NOVITHOR Termite Protection is not later damaged. This method is illustrated in Figures 20B – 20K below.

Figures 20A – 20C Use a 4¼ inch battery powered angle grinder with a diamond blade wheel to cut the pipe flush with the concrete.



Figures 20D – 20F Then grind down around the pipe into the concrete to create a 4 mm deep trench around the pipe that is feathered to the outer edge of the trench.



Figure 20G Clean away all dust and debris to leave a smooth finish. Wash concrete with clean water.



Figures 20J The pipe penetration is now fully protected and should not be damaged by later trades.



Figures 20H – 20I Apply the NOVITHOR Cementitious Parge so as to fill the trench and ensure it is flush against the exposed walls of the pipe penetration.



This process should not take more than two minutes for a typical 100 mm penetration pipe.

NOVITHOR TERMITE PROOF CEMENTITIOUS PARGE
TERMITE BARRIER FOR PIPE CLUSTER

NOVITHOR TERMITE PROOF CEMENTITIOUS PARGE TO BE FILLED INTO THE PREPARED RECESS 4mm DEEP AND THE EDGE OF THE **NOVITHOR TERMITE PROOF CEMENTITIOUS PARGE** SHALL BE MIN 50mm FROM THE EDGE OF PIPES ON ALL SIDES

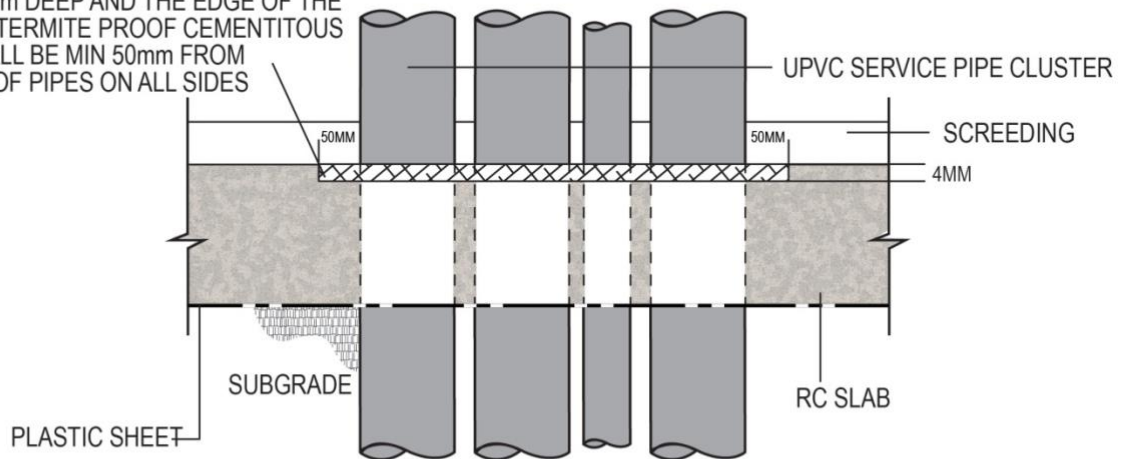

NOVITHOR TERMITE PROOF CEMENTITIOUS PARGE
TERMITE BARRIER FOR PIPE CLUSTER

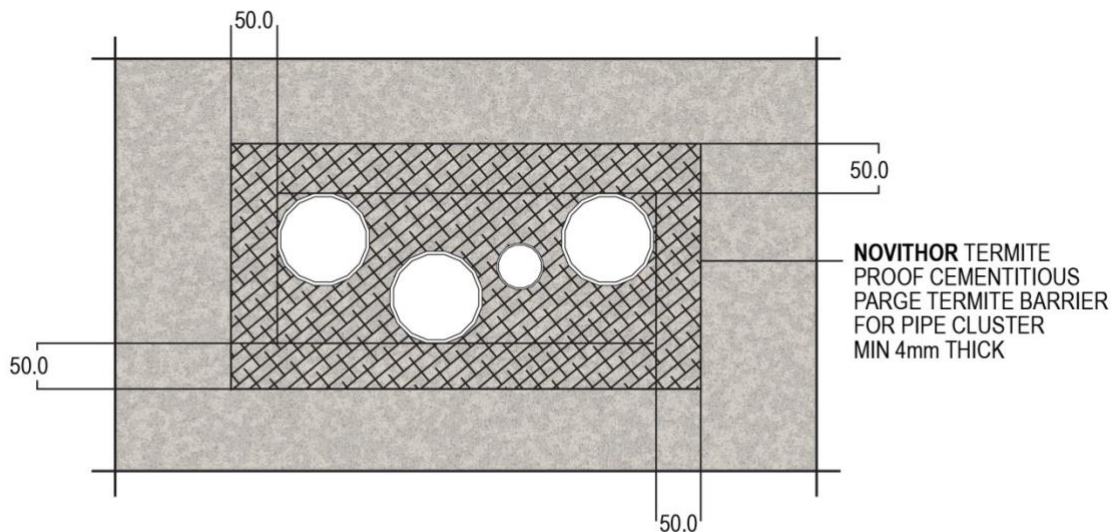

Figure 21

Multiple Penetrations

For multiple penetrations treat as shown below.



Figure 18 Remove loose dirt from around pipe and concrete.



Figure 21 Ensure joint between pipe and concrete is fully covered.



Figure 19 Apply NOVITHOR Cementitious Pargolite with soft bristled brush.



Figure 22 Ensure joint between pipe and concrete is fully covered. Cover cold joint between slab and RC column.



Figure 20B Apply NOVITHOR Cementitious Pargolite with soft bristled brush.



Tilt Panels



Figure 24 Tilt panel slab placed by builder.



Figure 25 Tilt slab panel to be grouted with NOVITHOR Cementitious Parge.



Figure 26 NOVITHOR Cementitious Parge positioned below tilt panel and on concrete slab.

Hebel Power Panels



Figure 27 NOVITHOR Cementitious Parge applied over CSL Hebel and concrete slab edge.



Figure 28 NOVITHOR Cementitious Parge applied over CSR Hebel and concrete slab edge.



Figure 29 NOVITHOR Cementitious Parge applied over CSR Hebel and concrete slab edge.



Figure 31 Example of NOVITHOR Cementitious Parge applied as grouting between tilt slab panel and concrete slab.



Figure 30 NOVITHOR Cementitious Parge applied over CSR Hebel and concrete slab edge.

Capping Retaining Wall



Figure 32 NOVITHOR Cementitious Parge capping RC block wall



Figure 33 NOVITHOR Cementitious Parge extending 75 mm down RC block wall to create a minimum 75 mm inspection zone.

Figure 35

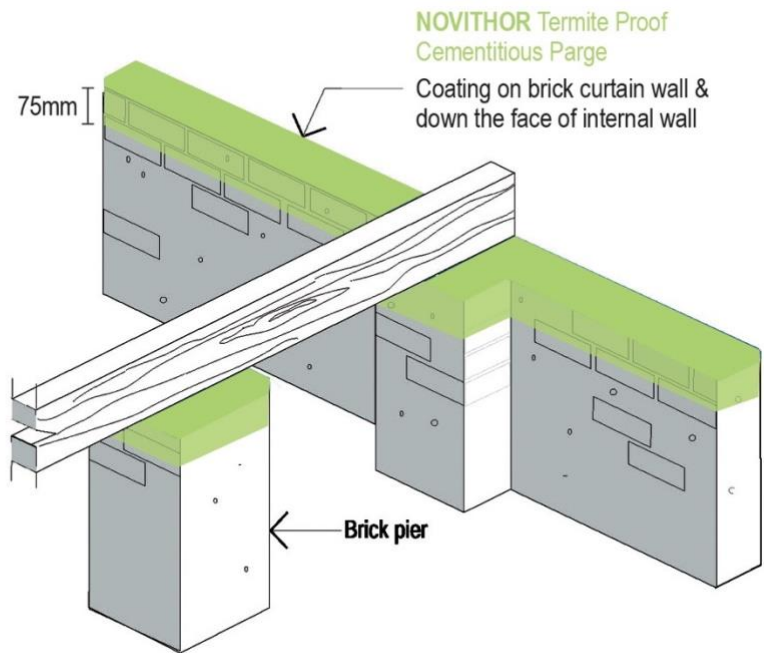
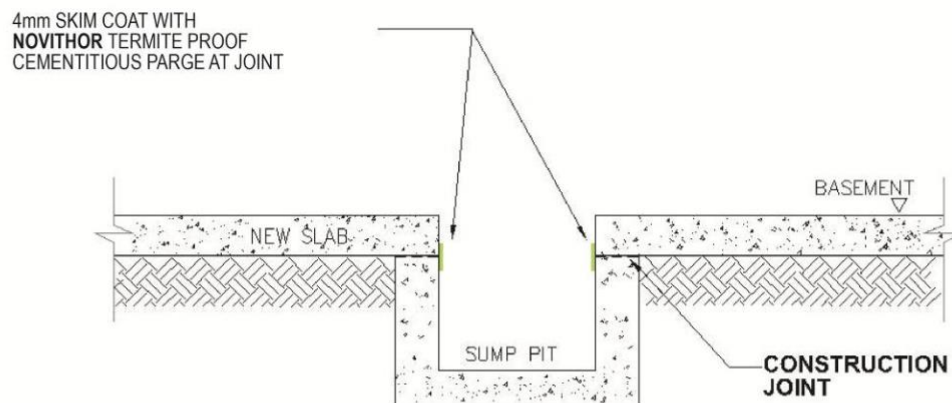

Figure 34



TYPICAL SUMP PIT DETAIL FOR BASEMENT CARPARK

SCALE : N.T.S

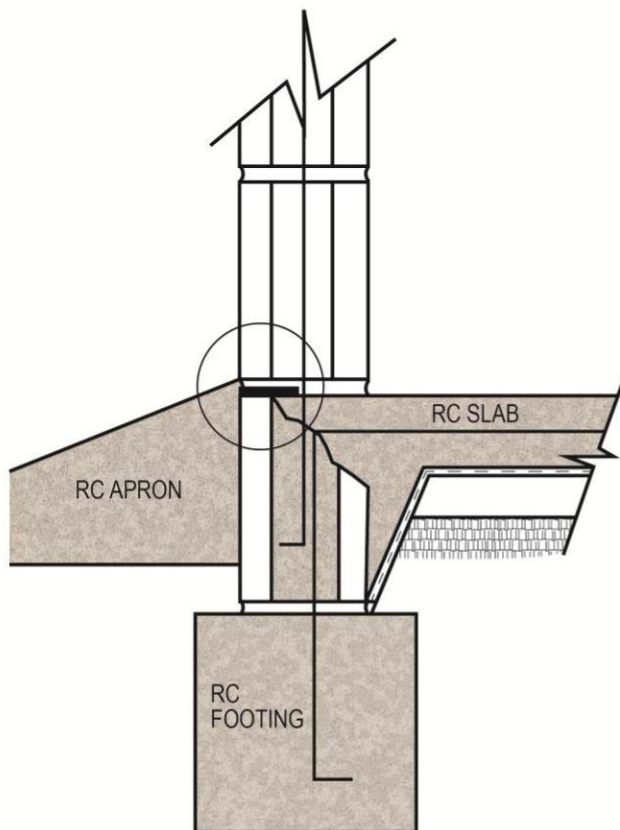
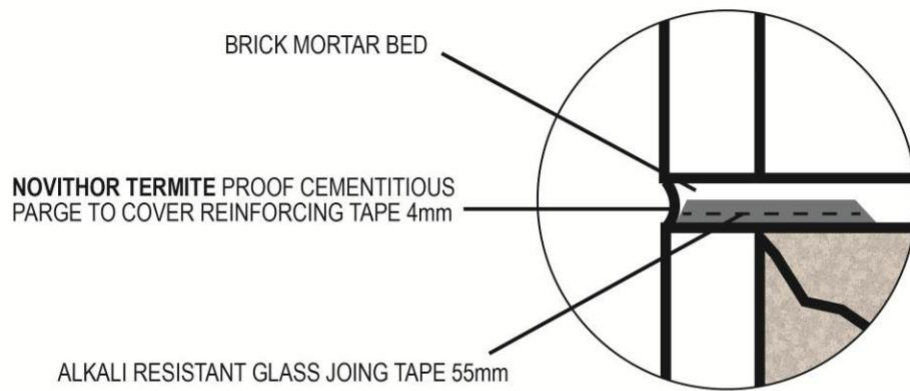

Figure 36

NOVITHOR Termite Proofing Resin

NOVITHOR Termite Proofing Resin is a termite proofing liquid designed to create a physical termite protection system against the ingress of subterranean termites by being applied to mortar or render. It soaks into the mortar joints, hardens the mortar, and stops attack by termites either pulling at the grains of sand and/ or by stopping the reaction of the formic acid with the cement in the mortar that termites produce, thus weakening the cement so the grains of sand can be extracted. On its own, NOVITHOR Termite Proofing Resin is not termite resistant, it works with the mortar.

NOVITHOR Termite Proofing Resin is a unique combination of silicones and acrylic glazing liquid. Surfaces treated also resist efflorescence and salt staining and are not only water repellent but sealed to resist penetration of rainwater under wind pressure.

It will also highlight the natural colour of masonry.

NOVITHOR Termite Proofing Resin is used externally or internally and meets the requirements of Australian Standards AS 3660.1 2000 and AS 3660.3.

Benefits

- Easily applied by brush or low-pressure spray.
- Dries clear and enhances the natural colour of masonry surfaces.
- Prevents termite's formic acid reacting with mortar.
- It is identified by traceable elements.
- Easy two coat application.
- Minimum 50-year life expectancy.
- Suitable for post and pre-construction applications.
- Reduces/stops efflorescence in treated brickwork.
- Reduces water absorption in treated brickwork.
- Hardens brickwork, mortar and render by its unique ability to penetrate and interface as part of the matrix of the masonry.
- Water proofing membranes may be applied directly over NOVITHOR Termite Proofing Resin treated retaining walls.
- May be applied to internal masonry surfaces.
- Ideal for zero allotment buildings.

Application Directions

Surfaces Concrete and Masonry Walls

Substrates Concrete, cement renders brickwork

NOVITHOR Termite Proofing Resin is applied to the lower courses of brickwork from the footing or slab edge until 75 mm above finished ground level.

NOVITHOR Termite Proofing Resin is applied to render extending from the footing or slab edge until 75 mm above finished ground level.

VERY IMPORTANT

Before applying NOVITHOR Termite Proofing Resin ensure ALL surfaces have been thoroughly cleaned and mortar stains have been removed with acid wash.

PRECAUTIONS

As all substrates are different, always apply to a small sample area first, to confirm suitable preparation, penetration, and effect.

NOVITHOR Termite Proofing Resin is flammable.
NO SMOKING. NO NAKED FLAMES.



Observe all usual precautions with solvents. Use only under well ventilated conditions.

To clean brushes and equipment use lacquer thinners of DUCO type.

Rendered building

NOVITHOR Resin must be applied prior to rendering to ensure effective, long-term proofing of the building.

It is a requirement of the *NCC Building Code of Australia* to provide a strike line for rendered buildings. This also serves to provide a visual inspection zone for the NOVITHOR Resin coated brick underneath the rendered surface and provides a guide for future visual inspections to show that the inspection zone has not been concealed, bridged, or breached.

Installation Video Link

Please see:

<http://novithor.com/images/Novithor-SD-540.mp4>

VERY IMPORTANT:
All holes in mortar joints where NOVITHOR Termite Proofing Resin is must be filled with matching mortar.

It is recommended that mortar joints on new buildings be ironed or struck in areas to be treated with NOVITHOR Termite Proofing Resin.

Apply NOVITHOR Termite Proofing Resin on a day where weather is to be fine, **do not apply in wet conditions.**

When surfaces are thoroughly dry, apply NOVITHOR Termite Proofing Resin with brush or low-pressure spray.

Apply NOVITHOR Termite Proofing Resin to brickwork ensuring mortar joints are flood coated from footing to 75 mm above finished ground level.

Apply NOVITHOR Termite Proofing Resin to render ensuring surface of render is flood coated from footing to 75 mm above finished ground level.

Coverage

Quantities below will allow for a two-coat application.

Brickwork	1 Litre per 2 sq. metres
Concrete & cement render	1 Litre per 2 sq. meters
Concrete block	1 Litre per 2 sq. meters

Note: NOVITHOR Termite Proofing Resin is only to be applied as supplied, do not dilute.

Shake or stir drum well before applying NOVITHOR Termite Proofing Resin to masonry surfaces.

Cleaning Equipment

To clean brushes and spray equipment use lacquer thinners of DUCO type e.g. (Xylene) and then flush with clean tap water.



Figure 37 NOVITHOR Resin being applied to mortar joints in retaining wall.



Figure 38 NOVITHOR Resin applied to rendered wall.



Figure 39 Applied to face bricks work. 1st coat focus on mortar joints; 2nd coat cover brick face to blend any runs.



Figure 40 Resin being applied to rendered wall.



Figure 41 NOVITHOR Resin being applied to mortar joints in retaining wall.

NOVITHOR Termite Proofing Resin V-Joint Application

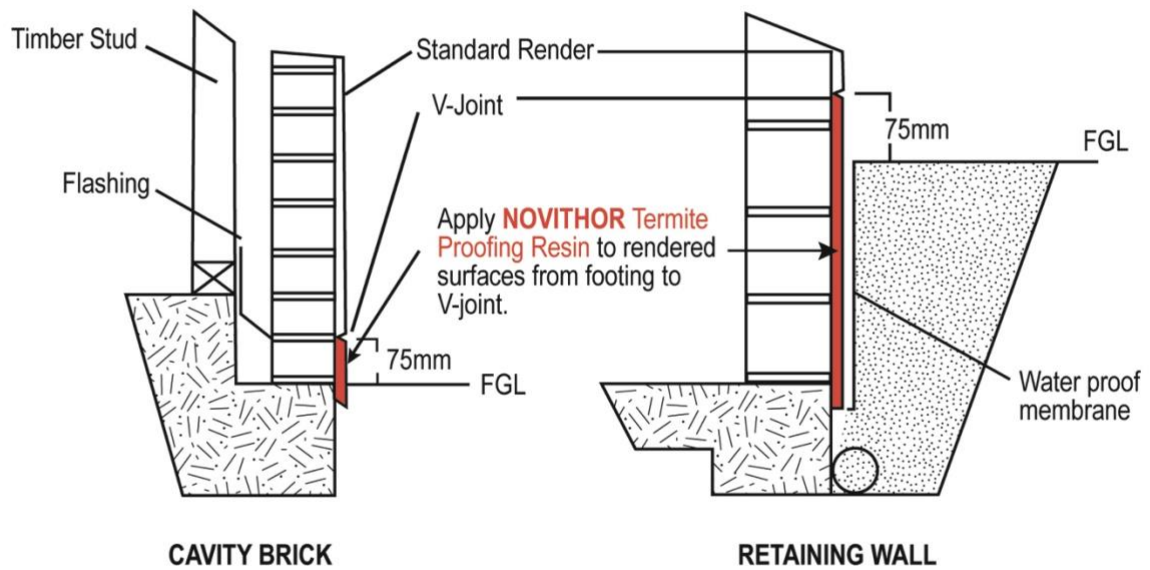

Figure 42

NOVITHOR Termite Proofing Resin

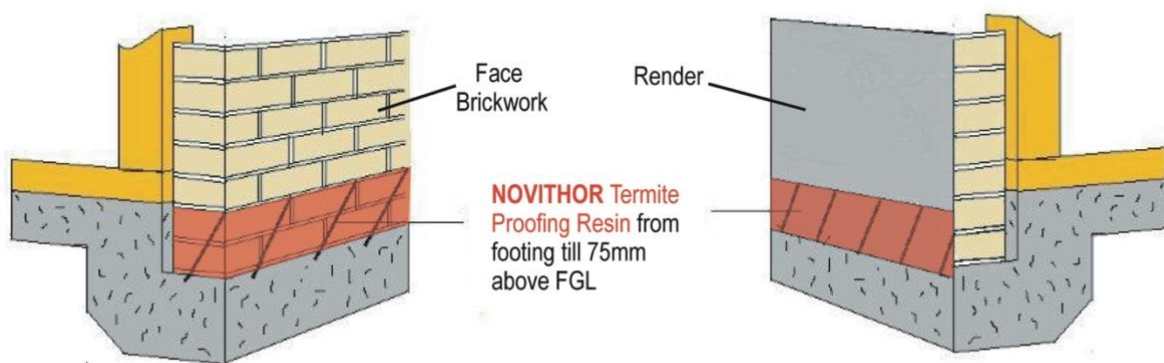

Figure 43

NOVITHOR Termite Proof Flex-Gel

is a Neutral cure, 100% gel rubber sealant and glue based on silicone. It cures at room temperature to provide excellent resistance to termites, weathering, ultraviolet radiation, vibration, moisture, ozone, temperature extremes, airborne pollutants, and many cleaning detergents and solvents. It is grey in colour and non-slumping.

Benefits

- Resists the growth of mould and mildew
- Superior adhesion to a wide range of building materials including concrete and brickwork
- Long life reliability and low maintenance at temperatures from -50°C (-58°F) to +150°C (+302°F)
- Can be packed and applied in any season
- Can be applied in vertical and overhead joints

Uses

NOVITHOR Termite Proof Flex-Gel is a high-performance neutral cure gel sealant and adhesive specifically formulated for indoor/outdoor or confined space applications. It is used for sealing applications on zincalume, galvanized iron, anodized aluminium, coated steel products, concrete, brick veneer, aerated concrete (AAC) & rigid PVC. It is suitable for sanitary applications due to the presence of a mould inhibitor.

Typical Properties

NB These values are not intended for use in preparing specifications. Please contact the Ensystem office prior to writing specifications on this product.

Parameter	Unit	Value
As supplied - tested at 250C, 50% relative humidity		
Flow, sag, or slump	mm	Nil
Working time	minutes	10
Surface cure time	minutes	35
Specific gravity	g/mL	1.03
As cured - tested at 250C, 50% relative humidity		
Hardness, shore A	Points	20
Ultimate tensile strength	MPA	>1.1
Ultimate elongation	%	>300
Modulus at 100%	MPA	0.5
Movement capability	%	25

Application Directions

1. Correct joint design reduces stress on the sealant, enables optimum movement capability, assists sealant application, and reduces the potential for sealant splitting and voiding.
2. Guidelines are:
 - a. Minimum joint width - 2 mm.
 - b. Minimum joint depth - 6 mm.

For larger joints, the width of the joint should be greater than the sealant depth. Avoid 3-sided adhesion; Apply backer rod or bond breaker tape in the base of the joint to ensure the sealant is only bonded to the sides of the joint.

3. Clean all joint surfaces. Surfaces must be clean, dry, and sound. Remove loose debris and/or old sealant.

General Recommendations

For non-porous surfaces: Solvent wipe the joint surfaces using a non-oily solvent such as methyl ethyl ketone, white spirits, or mineral turpentine on a clean white lint-free cloth to remove any oils or contaminants. Immediately wipe with a second dry cloth to remove any traces of solvent and contamination.

For porous surfaces: Wire brush or abrade the surfaces to remove loose debris, old paint, and other contaminants. Remove dust with an oil-free compressed air blast and/or high-pressure water blast. Allow to dry before sealing. If necessary, solvent wash and dry.

Priming. A primer may be needed for optimum adhesion to some substrates based on in-situ testing.

Install backing material. A backer rod (e.g., closed-cell polyethylene or open-cell polyurethane foam) or similar material (e.g., low tack polyethylene tape for shallow joints) can be used in the base of the joint to control sealant depth and avoid 3-sided adhesion by preventing adhesion to the base of the joint.

Mask adjacent surfaces with masking tape. This will ensure a clean, neat appearance and reduce clean up by protecting surrounding areas from excess sealant.

Apply sealant. Dispensing equipment is required. Please contact Ensystem for purchase. Apply sealant into the base of the joint so that it completely fills the joint, wetting both sides.

Tool joint/remove masking tape. Tool the surface of the joint before the sealant forms a skin to provide a smooth even finish and to ensure the sealant adheres to the sides of the joint. Do not use soap or water as tooling aids. Remove masking tape immediately after tooling and before the sealant skins. After a skin has formed, do not disturb the joint for 24 hours. Avoid contact with cleaning agents and solvents (e.g., bleach) whilst sealant is curing. Uncured sealant can best be cleaned from tools using commercial solvents such as xylene, toluene, methyl ethyl ketone, or mineral turpentine.

Observe proper precautions when using flammable solvents. On porous surfaces, allow sealant to cure before removing by abrasion. Cured sealant is not soluble and must be trimmed with a blade. Avoid undercutting the seal.

Safe-handling

Before use, read product Material Safety Data Sheet and container label.

Useable Life and Storage

When stored at or below 30°C in the original unopened containers, this product has a useable life of 36 months from the date of manufacture.

Packaging

NOVITHOR Termite Proof Flex-Gel is supplied in a 300 g cartridge tube.

Limitations

- Do not use for structural glazing.
- Not recommended for continuous water immersion.
- Not recommended for polycarbonate plastic sheeting
- Paint will not adhere well to the sealant. Paint before applying sealant and ensure paint is thoroughly dry (particularly enamel or solvent based paints).
- Do not apply in contact with materials that bleed plasticisers, solvents or release by-products that may inhibit cure, affect adhesion, or discolour the sealant(e.g., bituminous adhesives and coatings).
- Do not clean or treat the sealant with materials, solvents, or cleaning agents that may affect or discolour the sealant, particularly during sealant cure.
- Do not use when substrate surface temperature exceeds 50°C.
- Do not use as a penetration fire stop sealing system.
- Do not apply to surfaces in direct contact with food or drinking water.
- Do not use on the reflective coatings on mirrors.

Warranty Information - Please Read Carefully

The information contained herein is offered in good faith and is believed to be accurate. However, because conditions and methods of use of our products are beyond our control, this information should not be used in substitution for customer's own tests to ensure that the product is effective and satisfactory for the intended end use.

Construction Joints

NOVITHOR Termite Proof Flex-Gel's high modulus elasticity and bond strength make its application ideal to a wide range of building products, including concrete, masonry, steel, aluminium, PVC, and galvanised steel.

Ultraviolet stability ensures the longevity of the gel. It is perfect for termite proofing construction joints and saw cuts in concrete, control joints in masonry walls, electrical conduits, joining galvanized ant caps, PVC pipes and in tilt panel construction.



Figure 44 NOVITHOR Flexi-Gel in control joint.



Figure 46 NOVITHOR Flexi-Gel between footing and garage floor in-fill slab.



Figure 45 NOVITHOR Flexi-Gel in joint between wall and pavement/ concrete apron.



Figure 47 NOVITHOR Flexi-Gel between footing and garage floor in-fill slab.

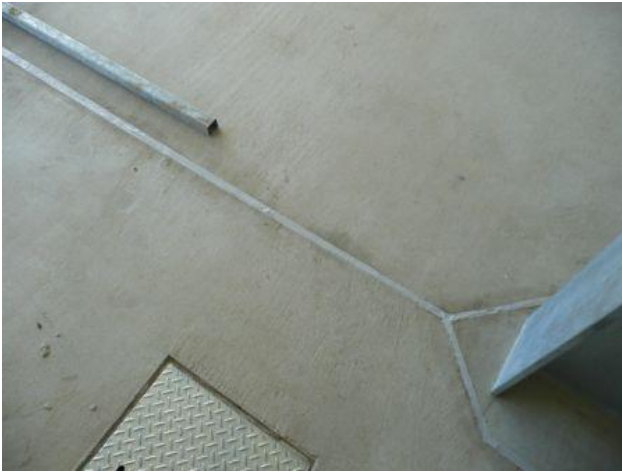

Figure 48 NOVITHOR Flexi-Gel protecting construction joint.



Figure 49 NOVITHOR Flexi-Gel around core drilled pipe.



Figure 50 NOVITHOR Flexi-Gel around column.

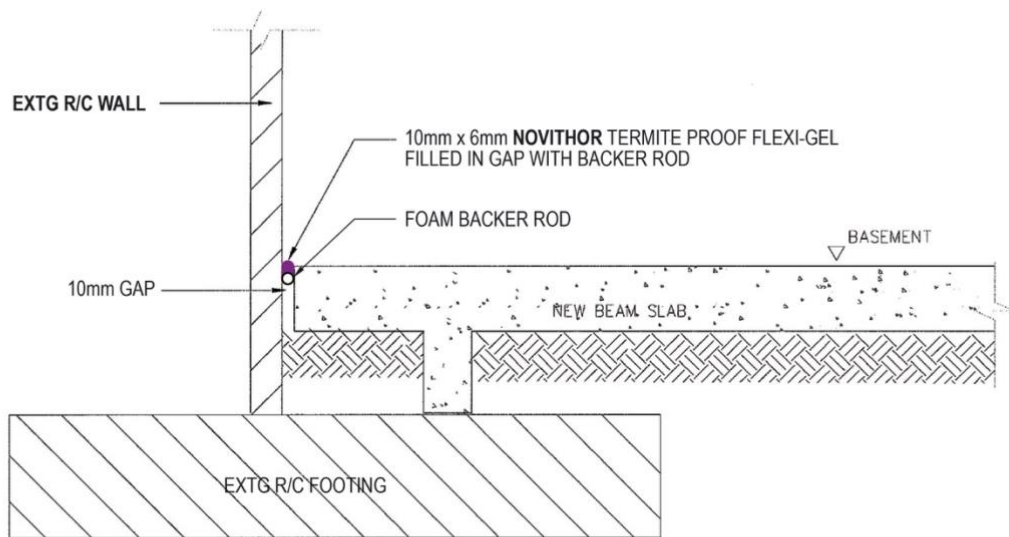

SECTION E-E

SCALE N.T.S.

Figure 51

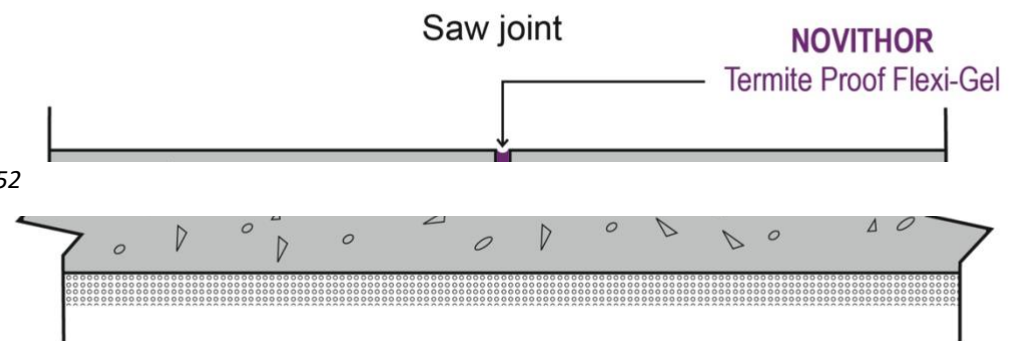
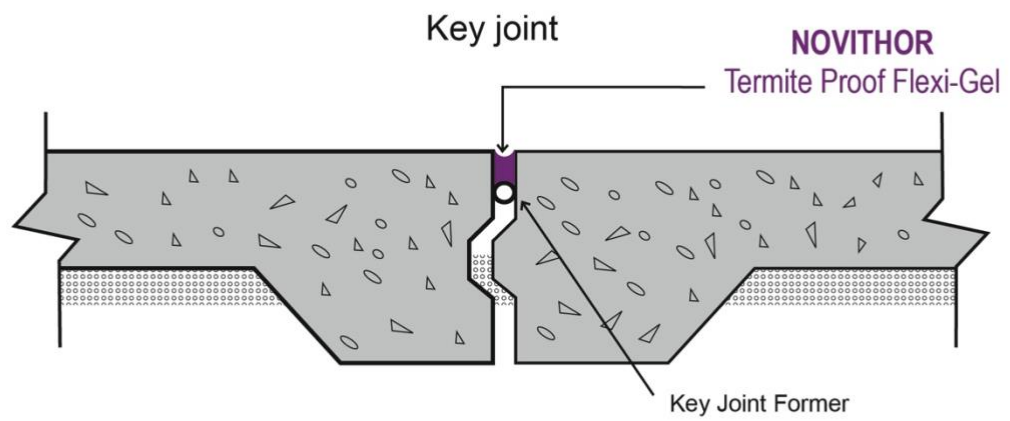
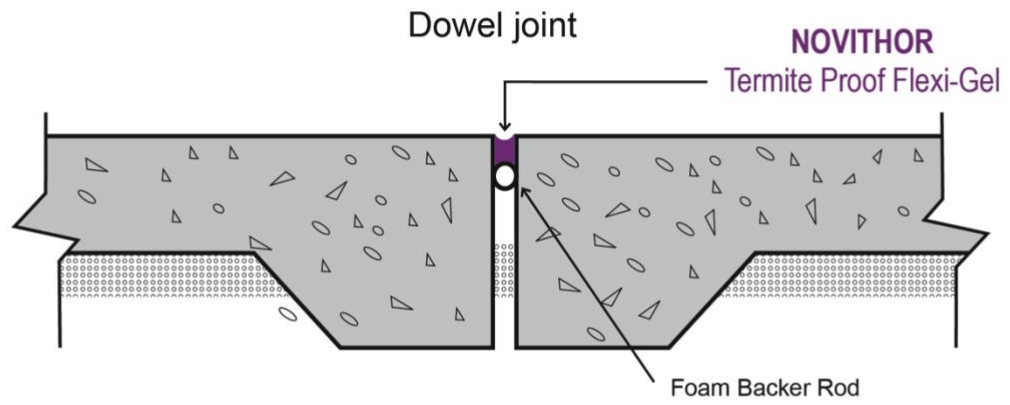

Figure 52

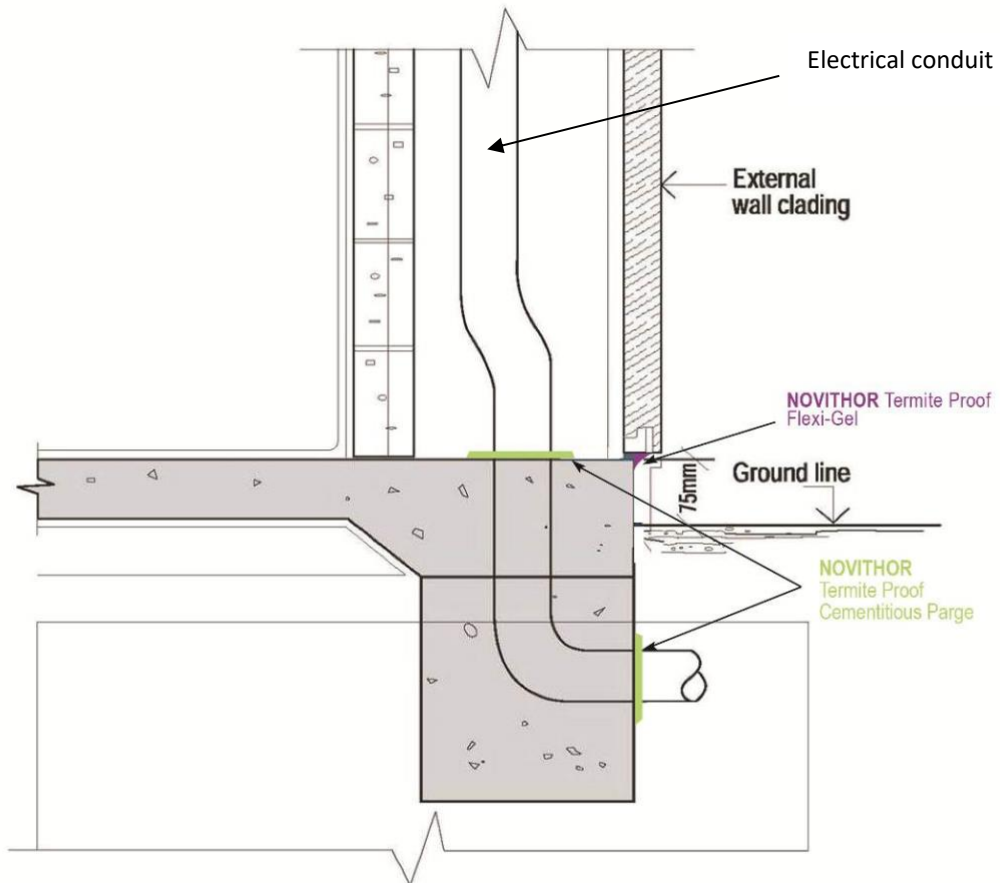
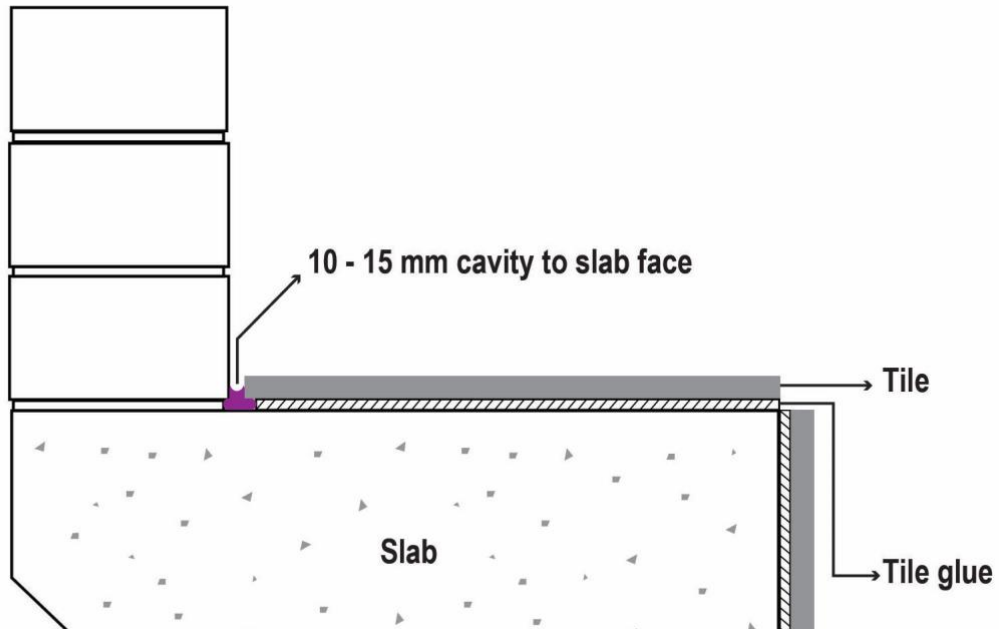

Figure 53

SIDE VIEW



TOP VIEW

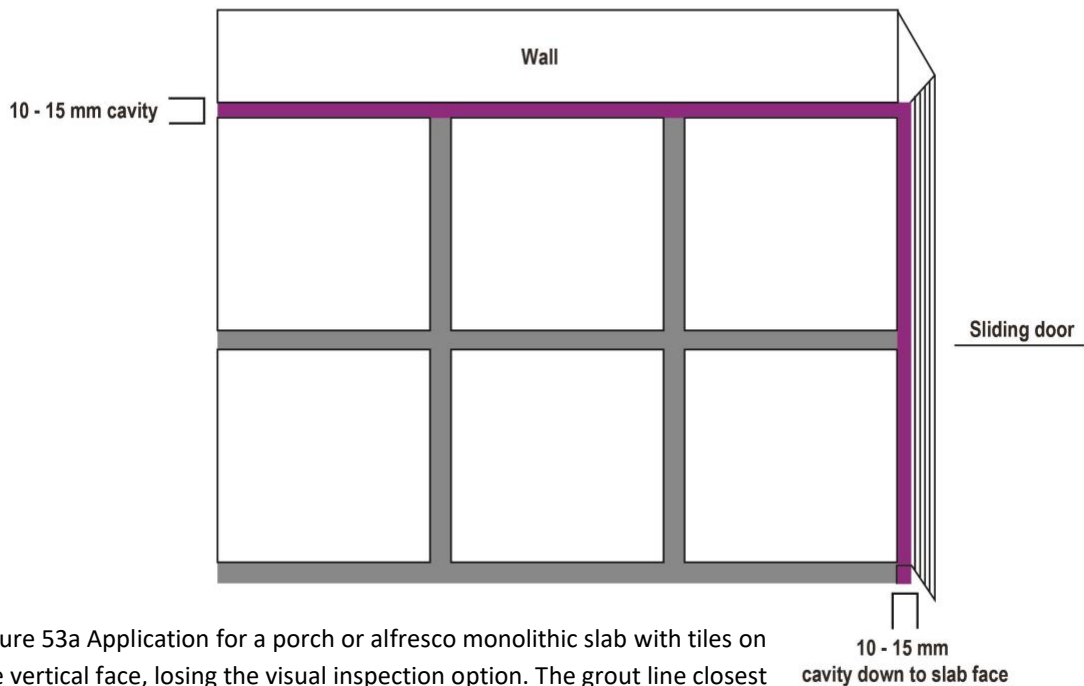

Figure 53a Application for a porch or alfresco monolithic slab with tiles on the vertical face, losing the visual inspection option. The grout line closest to the wall of the house must be cleaned out and replaced with a bead of NOVITHOR Flexi-gel at the slab level next to the last tile.

The successful performance of a building exterior is frequently defined by its ability to keep termites and the elements outside, away from the building's occupants. One of the critical links to ensuring a termite proof building is the joint sealant. Building joints can be sealed effectively by following a few simple guidelines for design in workable joints, selecting the correct termite proof sealant, performing appropriate surface preparation, and performing quality checks to ensure proper performance.

Joint Movement

Regardless of the size and height of structures, joint movement inevitably occurs from various factors such as changes in temperature, seismic movement, elastic frame shortening, creep, live loads, concrete shrinkage, moisture induced movements and design errors. Therefore, each joint should be designed to absorb these movements, using the correct sealant.

When movement is caused by temperature change, the degree of joint movement for each material should be considered since all materials have their own coefficient of linear thermal expansion (CTE). Joint movement caused by thermal expansion can be calculated by the following equation:

$$\text{Movement (Mt)} = \text{CTE} \times \text{Temp. Change} \times \text{Length of Material}$$

Average Coefficients of Linear Thermal Expansion for Building Materials - Reference ASTM C-1193

Material	mm/mm/°C x 10 ⁻⁶	in/in/°F x 10 ⁻⁶
Glass	9.0	5.0
Aluminium	23.2-23.8	12.9-13.2
Granite	5.0-11.0	2.8-6.1
Marble	6.7-22.1	3.7-12.3
Concrete	9.0-12.6	5.0-6.0
Stainless Steel	10.4-17.3	5.8-9.6
Acrylic	74.0	41.0
Polycarbonate	68.4	38.0

Note: The coefficient of expansion for natural materials (brick, stone, wood, etc.) or fabrications of natural materials can be highly variable. If a specific material is contemplated, then the coefficient for that material should be established and used rather than an average value. Moisture induced movement of brick masonry will cause the brick to swell and reduce joint sizes over the life of the project.

Joint Types

From a functional point of view, joints for construction can be put into two classes depending on the degree of movement.

Working Joints

Working joint are joints in which the shape and size of the sealant joint changes dramatically when movement occurs. Usually, a working joint occurs on the building envelope when different materials abut each other, or joints are designed to allow thermal expansion of materials. Typical examples of working joints include Control Joints, Expansion Joints, Lap Joints, Butt Joints, and Stack Joints.

Fixed Joints

Fixed Joints are joints which are mechanically fixed to prohibit movement. Movement is generally less than 10% of joint width. These joints are typically designed as air and/or water seals in curtain walls.

Joint Design

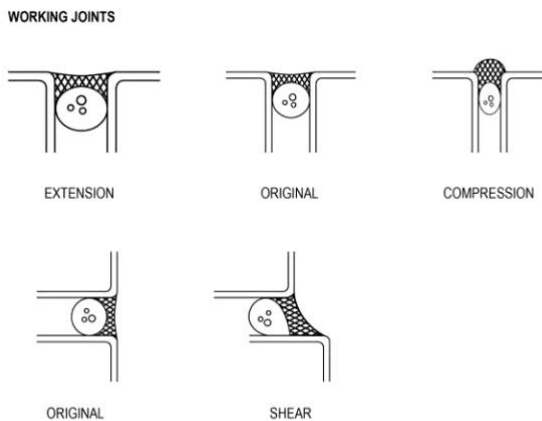

Figure 54 – Working Joints Applications

NOVITHOR Termite Proof Flex-Gel has been designed to perform when installed in compliance with accepted termite sealing procedures.

A few underlying principles are critical to consider in all joint designs using termite proof silicone sealants.

In all cases, a minimum depth of 6 mm sealant/ substrate bond is necessary to ensure adequate adhesion.

A minimum width of 6 mm is necessary to ensure that sealant applied from a caulking gun will flow into the joints. **Note:** In some cases where the sealant is used simply as a non-moving bedding compound and is applied to one substrate before both substrates are pressed together, thinner joint dimensions are acceptable.

NOVITHOR Termite Proof Flex-Gel requires atmospheric moisture to fully cure. Therefore, the sealant joint must be designed to ensure that the sealant is not isolated from air.

Moving Joint Considerations

When designing moving joints, the following points need consideration:

A minimum 6 mm joint width is recommended. Wider joints accommodate more movement than narrow joints.

Three-sided adhesion limits the amount of movement that a joint can accept without inducing a tear. Three-sided adhesion can be eliminated by the addition of a bond breaker tape or backer rod. With three-sided adhesion, no more than +/-15 per cent movement can be accommodated.

A thin sealant joint (6 mm +/- 3 mm) will accommodate more movement than a thick joint. Optimum performance is observed when the joints are shaped like an hourglass.

As a practical matter, as the sealant joint width becomes larger than 25 mm, the depth should be held at approximately 9 - 12 mm. There is no need for greater sealant depth with NOVITHOR Termite Proof Flex-Gel.

$$\text{Minimum Joint Width} = 100 \div X (Mt + MI) + T$$

X = Sealant Movement Capacity (%)

Mt = Movement due to thermal expansion

MI = Movement due to Live loading

T = Construction Tolerance

E.g., A horizontal joint between an aluminium curtain wall and a concrete panel with a thermal movement of 8 mm, a live load movement of 6 mm, a construction tolerance of 6 mm and 25 % movement capacity sealant would be:

$$\text{Width} = 100 \div 25 \times (8 + 6) + 6$$

$$\text{Width} = 62 \text{ mm}$$

Joint movement in Shear

When joints move in shear, greater joint movement can be accommodated since actual movement on the sealant is less. The joint width required (A) for joint movement (B), is as calculated below, or the allowable movement (B) for a particular joint width dimension (A), can be calculated using Pythagoras' Theorem. The new joint width after movement (C) is limited by the movement capability of the sealant in shear in a termite proof joint configuration. The calculation is as follows:

$$A^2 + B^2 = C^2 \text{ where}$$

A = original joint width

B = joint movement

C = new joint width after joint movement

Movement During Cure

NOVITHOR Termite Proof Flex-Gel cures by reacting with atmospheric moisture. Joint movement during cure can cause unsightly aesthetics due to joint deformation e.g., wrinkling. Premature adhesion loss can also occur because the adhesive characteristics of the sealant are obtained after the sealant has cured. Adhesion loss due to movement during cure can be minimized by the use of a primer. Primers can decrease the adhesion cure time lag. 'Wrinkling' can be minimized by following these guidelines:

Use open cell polyurethane backer rod

Seal when the joint surface is cool and will experience minimum temperature changes, typically in the late afternoon or early evening.

Place no more than 6 mm of sealant over the backer rod at the centre.

These suggestions should help minimize wrinkling, but may not eliminate it, as all sealants are prone to this aesthetic issue.

Backer Materials

A backer rod is the typical backer material for most termite proof joints. The role of a backer rod is to allow NOVITHOR Termite Proof Flex-Gel to be installed and tooled to a proper joint profile. Once it cures, the backer material must not restrict the movement of the sealant or cause *3-sided adhesion*. To provide sufficient backpressure during sealant installation, the backer rod should be sized 25 % larger than the joint opening. Sizing differs among backer rod types; refer to manufacturer's recommendations.

Generally, three common backer rod types can be used with NOVITHOR Termite Proof Flex-Gel:

- Open cell polyurethane
- Closed cell polyethylene
- Non-gassing polyolefin

Each backer rod type has demonstrated successful performance with NOVITHOR Termite Proof Flex-Gel. When selecting a backer rod, consider the following:

1. **Open cell polyurethane backer rods** allow the NOVITHOR Termite Proof Flex-Gel to cure through the backer rod, which is beneficial when fast sealant cure is desired. It can absorb water, which may have a detrimental effect in certain joint types.
2. **Closed cell polyethylene backer rods** may outgas if punctured during installation, requiring them to be left for 20 minutes before application.
3. **Other back-up materials** such as expanding foam tapes or glazing gaskets should be reviewed or tested for compatibility prior to use.

When a backer rod cannot be positioned in a joint opening, Teflon or polyethylene tape should be used to prevent *3-sided adhesion*.

EIFS Consideration

Exterior Insulation and Finish Systems (EIFS) are a new and growing segment of the exterior cladding market. EIFS offer unique challenges due to their composition. NOVITHOR Termite Proof Flex-Gel has a demonstrated history of success when used with Exterior Insulation and Finish Systems. NOVITHOR Termite Proof Flex-Gel offers unique benefits over organic sealants when used with EIFS.

Termite proof Design

Examples of a variety of termite proof joints follow with a review of joint type for key points and concerns.

Conventional Moving Termite Seal

GOOD JOINT DESIGN

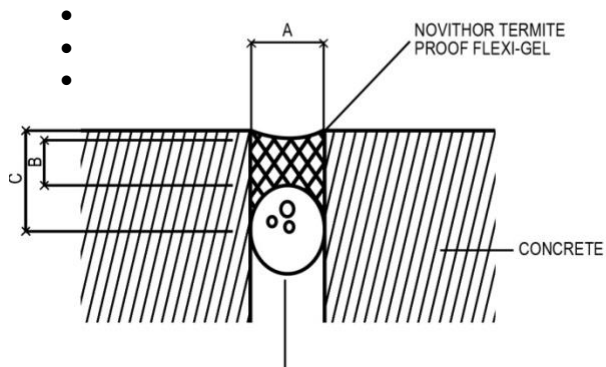

POOR JOINT DESIGN

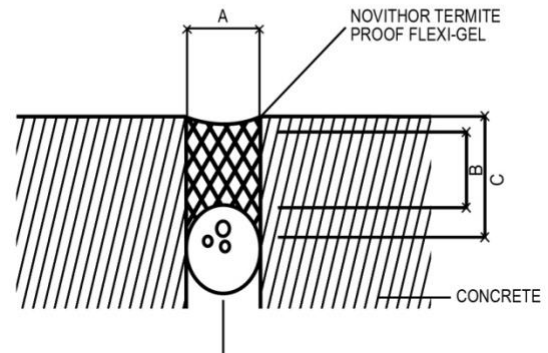

Figure 55

Good Joint Design

Dimension A must be at least 6 mm

Dimension B must be at least 3 mm

Dimension C must be at least 6 mm

Joint surface should be tooled.

Dimension B suggested maximum = 12 mm

Joints wider than 50 mm may slump slightly; therefore, double application techniques of the NOVITHOR Termite Proof Flex-Gel may be required.

Poor Joint Design

A deep sealant joint will not have the same movement capability as a properly designed joint.

Slow cure due to excessive sealant depth.

Moving Corner Joints (Filletts)

GOOD JOINT DESIGN

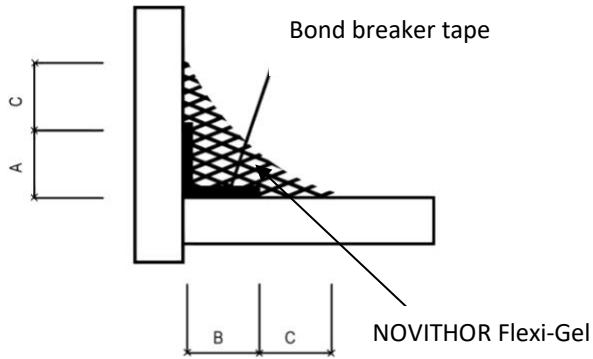

POOR JOINT DESIGN

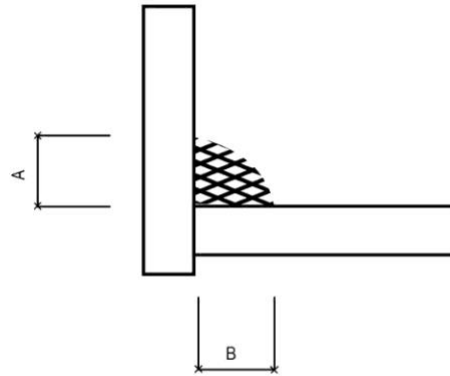

Figure 56

Good Joint Design

Dimension A and B must be at least 6 mm.

A bond breaker tape or backer rod must be present if joint movement is anticipated.

Joint must be tooled flat or slightly concave.

Dimension C must be at least 6 mm.

Figure 57

Poor Joint Design

Dimension A or B less than 6 mm.

Joint not properly tooled.

No bond breaker material; therefore, the joint will not accept movement.

Remedial Joints

GOOD JOINT DESIGN

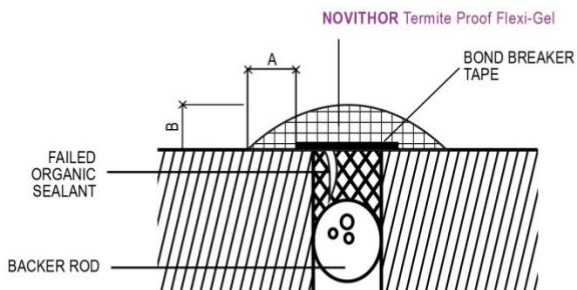
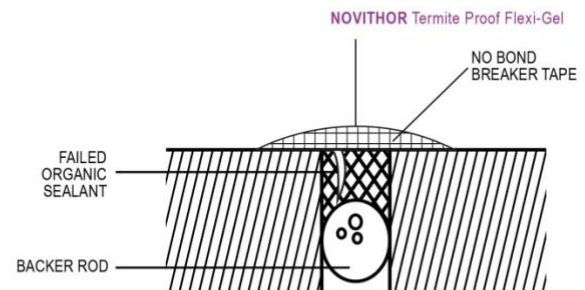

Figure 58

POOR JOINT DESIGN



Good Joint Design

Dimension A must be at least 6 mm.

Dimension B must be at least 3 mm.

Bond breaker tape must be used to isolate fresh sealant from failed organic weather seal and to allow joint movement.

Poor Joint Design

Dimension A less than 6 mm increases difficulty in obtaining adhesion and increases the likelihood for voids.

Dimension B less than 3 mm increases the likelihood of pinholes or voids in tooling; poor cohesive integrity.

No bond breaker material; therefore, the joint will not accept movement.

Movement Control Joints

Expansion joints (closing control and articulation joints) shall be clean and free from any hard or incompressible material for the full width and depth of the joint (before a backing rod and NOVITHOR Termite Proof Flex-Gel is inserted to prevent access of subterranean termites.

Garage Driveways / External Patio's

These areas are able to be treated by means of NOVITHOR Termite Proof Flex-Gel as a control joint.

Wall & Floor / Pipe Penetrations for Services

- a) Wall penetrations are to be treated with either, NOVITHOR Termite Proof Flex-Gel or NOVITHOR Termite Proof Cementitious Parge
- b) Floor penetrations are to be treated with either, NOVITHOR Termite Proof Flexi-Gel or NOVITHOR Termite Proof Cementitious Parge (as shown in this installation manual).

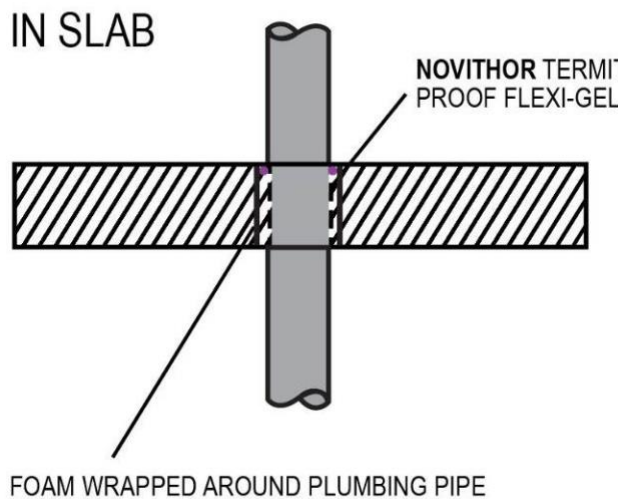

Figure 59

Estimating Sheet

A guide to NOVITHOR Termite Proof Flex-Gel quantities (for fillet work multiply metre runs per cartridge by two).

Joint size in mm	Litre NTPG	Metre run
	per metre	per 300 g cartridge
5 x 5	0.025	12.4
5 x 10	0.50	6.2
5 x 15	0.075	4.2
10 x 10	0.100	3.1
10 x 15	0.150	2
10 x 20	0.200	1.55
10 x 25	0.250	1.24
15 x 10	0.150	2.06
15 x 15	0.225	1.35
15 x 20	0.300	1.04
15 x 25	0.375	0.82
15 x 30	0.450	0.69
15 x 40	0.600	0.51
20 x 10	0.200	1.55
20 x 15	0.050	1.04
20 x 20	0.400	0.78
25 x 12	0.300	1.00
25 x 15	0.380	0.81
25 x 20	0.500	0.62
25 x 25	0.630	0.5
30 x 15	0.450	0.69
30 x 20	0.600	0.51
30 x 25	0.750	0.42
40 x 20	0.800	0.39
40 x 25	1.000	0.31
40 x 30	1.200	0.26

METHODS OF FLOOR SLAB POURING

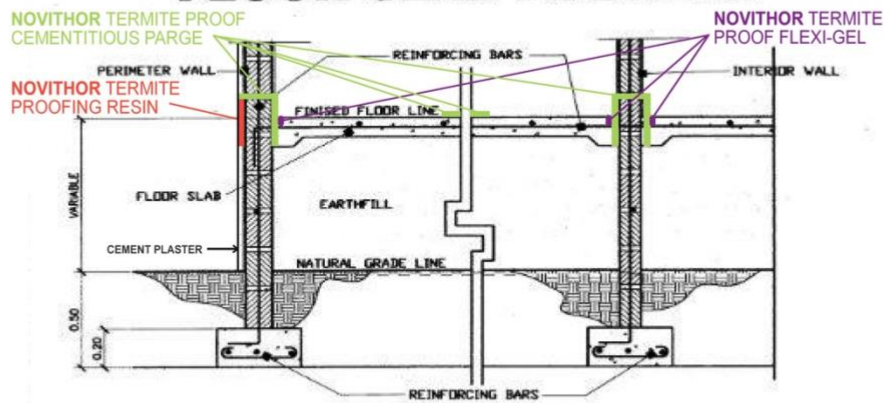

POURING BY SECTION/ AREA

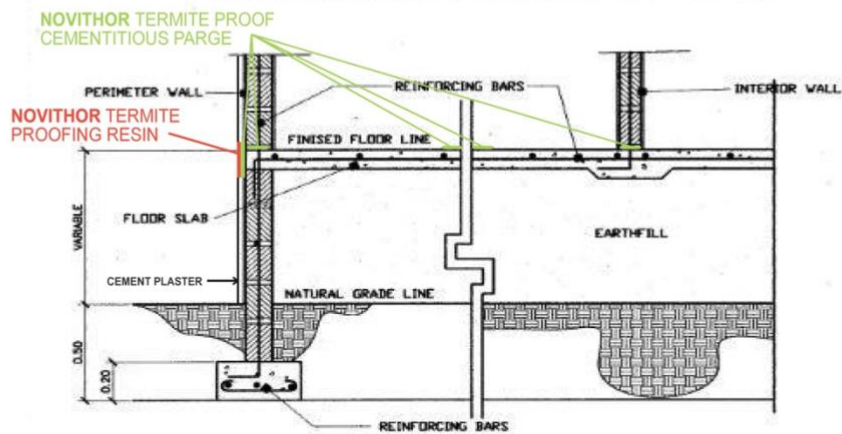

MONOLITHIC POURING

LEGEND

- NOVITHOR TERMITE PROOFING RESIN
- NOVITHOR TERMITE PROOF CEMENTITIOUS PARGE
- NOVITHOR TERMITE PROOF FLEXI-GEL

Figure 60

Special Installation Details

Figure 66

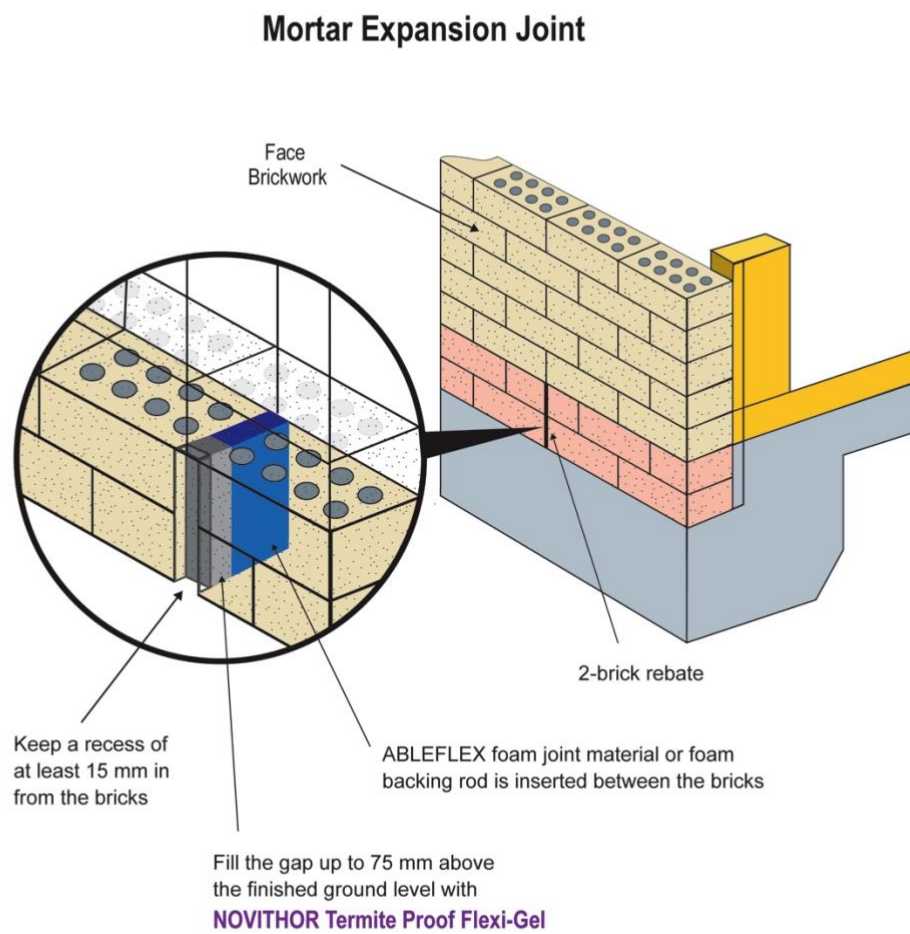

Garage Doors – QLD

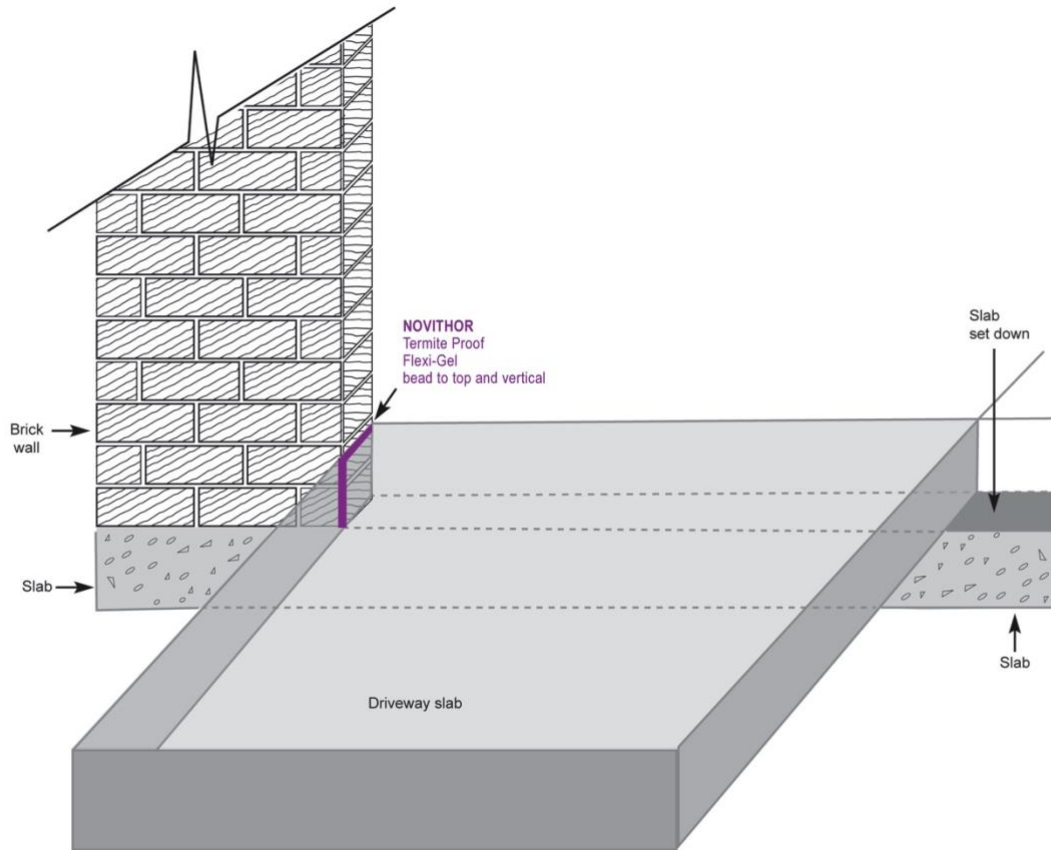

Figure 67

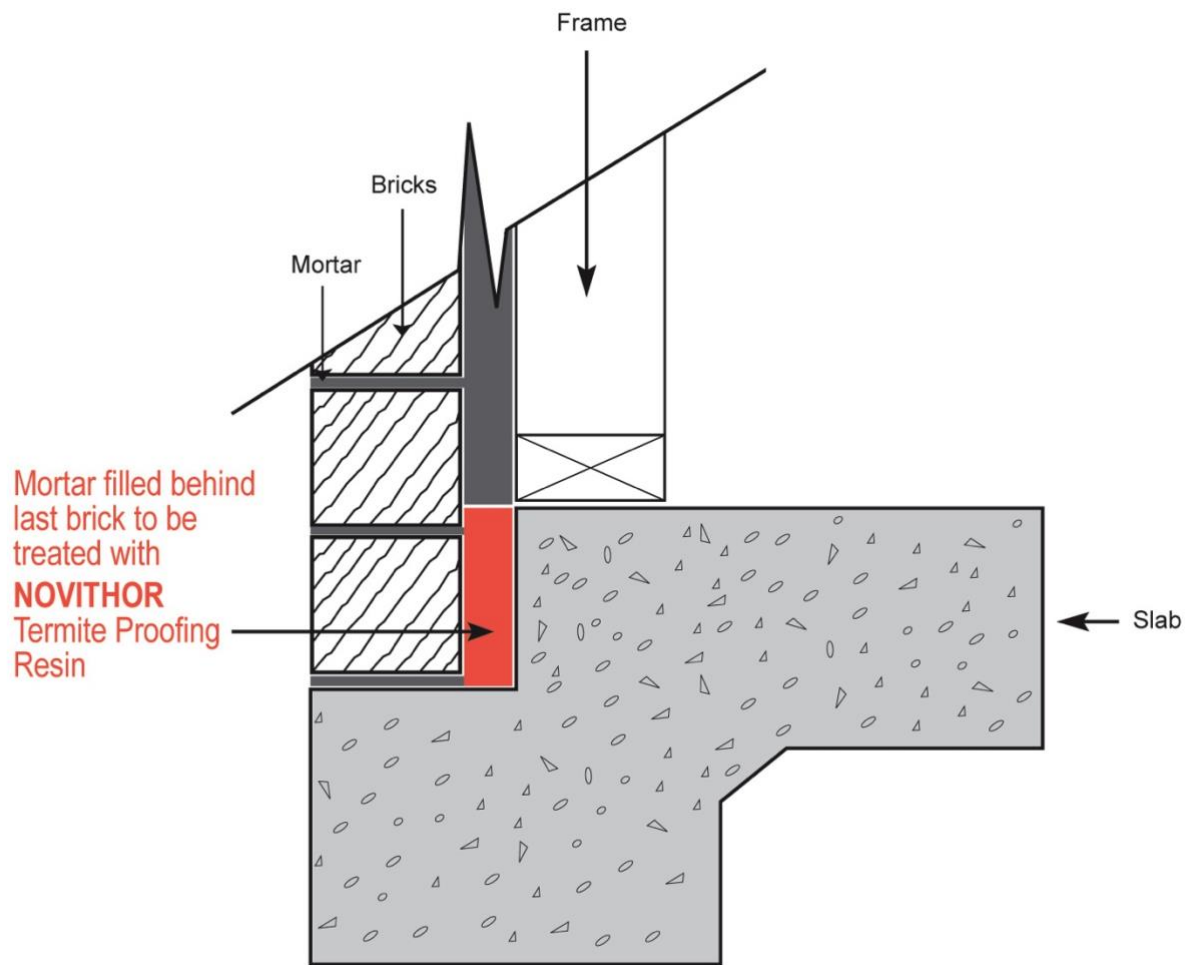

Figure 68

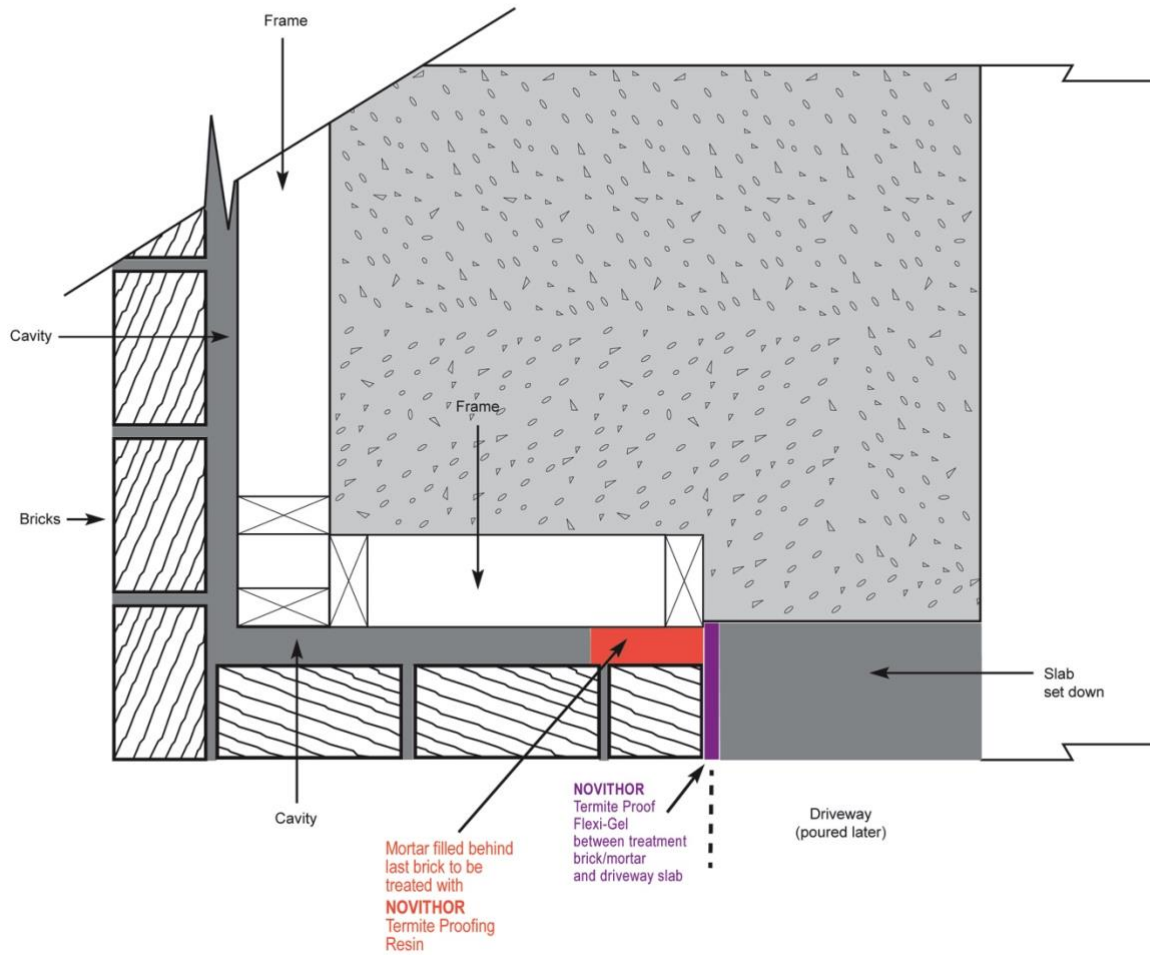

Figure 69

Garage with timber door jamb overhanging the driveway entry

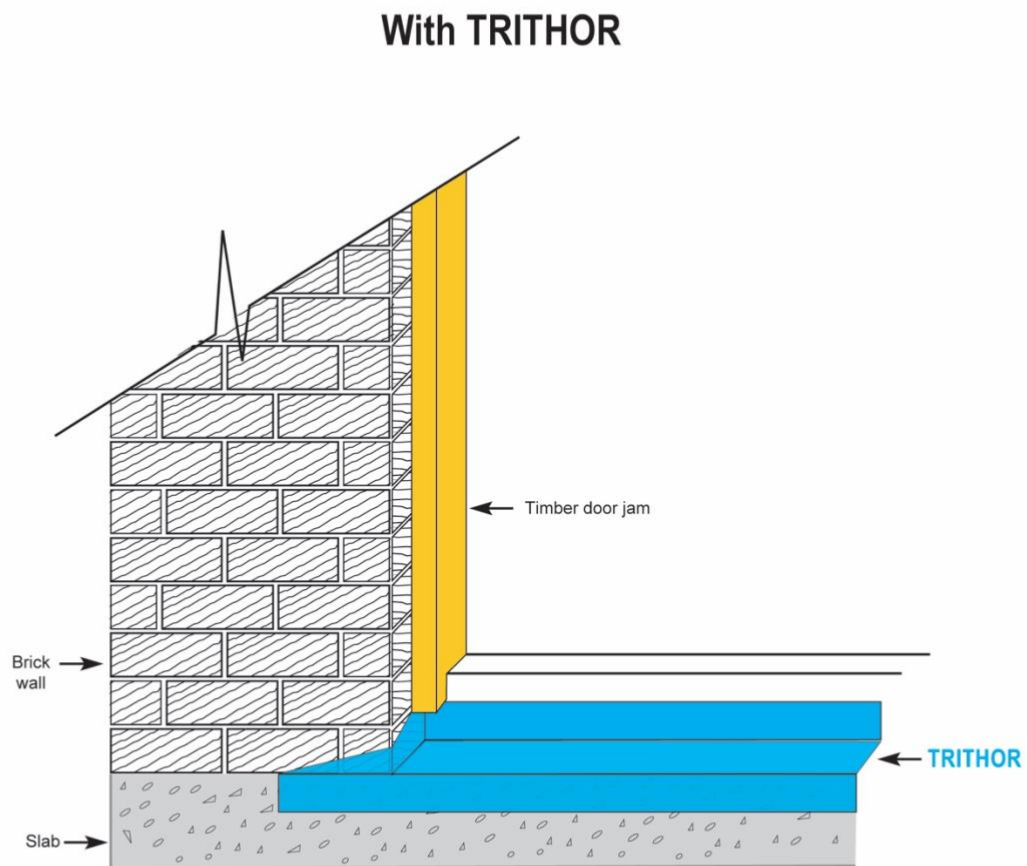

Figure 70

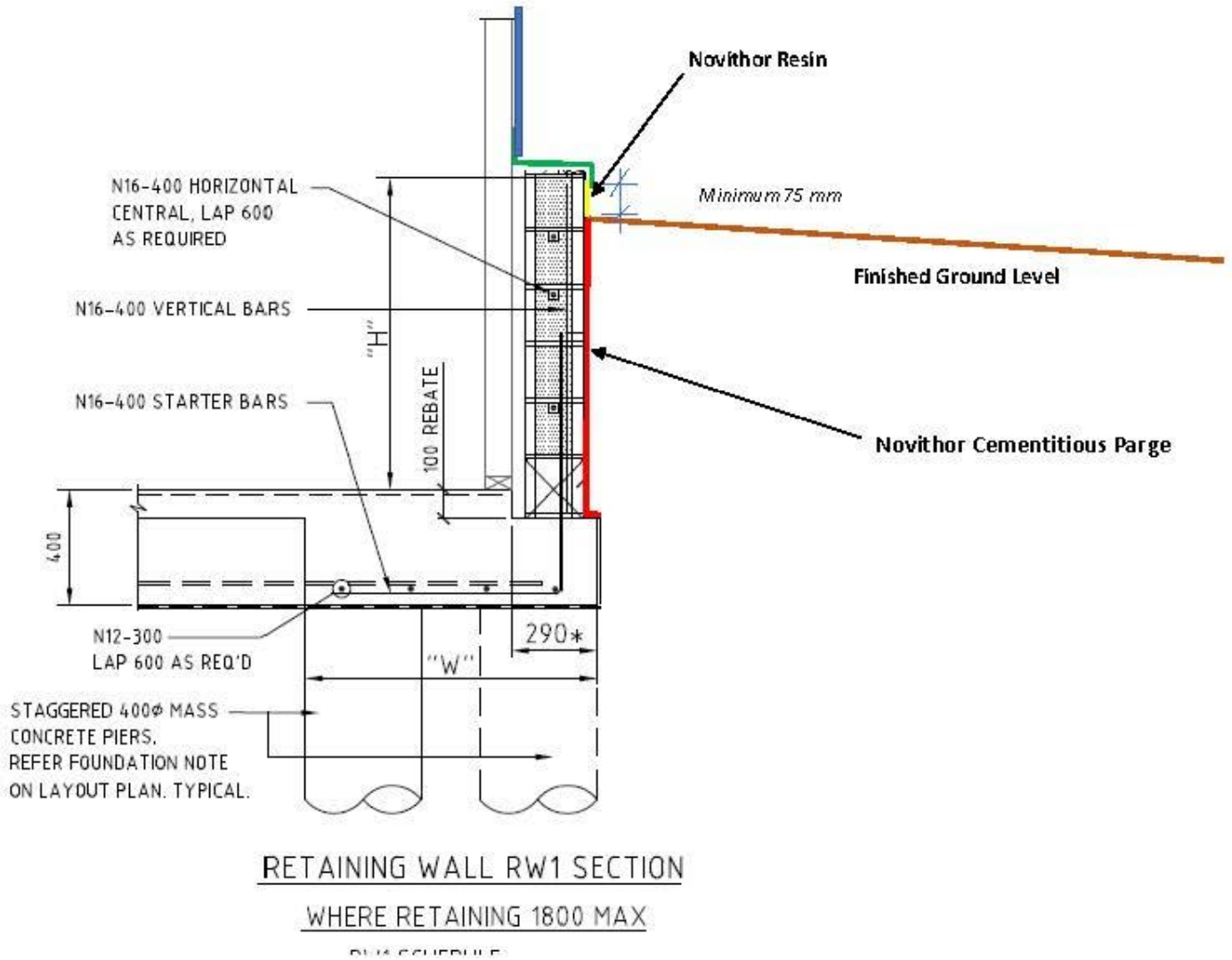

Figure 70 A

NOVITHOR Termite Proof Collars

NOVITHOR Termite Proof Collars provide the premium solution for pesticide free protection of pipe penetrations in new buildings. NOVITHOR Termite Proof Collars are made out of Ultra Marine Grade Aluminium, which is robust and able to withstand the harshest treatment and environments.

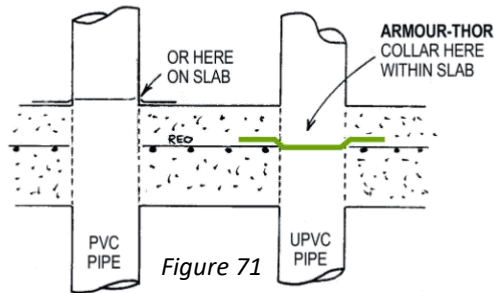

Figure 71

NOVITHOR Termite Proof Collars are used as a physical termite barrier around plumbing pipes and electrical conduits that penetrate through reinforced concrete slabs. They come in the following sizes and can be adapted to suit an even wider range of pipe sizes.

100 mm	43 mm
82 mm	19 mm
56 mm	12 mm

Since the Collars for pipe penetrations are made from Flex-temper aluminium they can be moulded into various shapes and can fit the tightest of situations e.g., two pipes side by side.

The internal flange on Collars is able to be cut and expanded to enable it to be fitted over flanged ends of pipes, once fitted over the flange, the collar is pressed back into its original shape and fastened onto the pipe with Termite Proof Flex-Gel.



Figure 72

Installation

In-Slab Fixing

1. Select the correct sized NOVITHOR Termite Proof Collar, ensuring a neat fit is achieved, with the internal flange extension facing down.
2. The Collar is positioned at the height of the chaired steel reinforcement.
3. Seal between pipe and the Collar with NOVITHOR Termite Proof Flex-Gel. Ensure all surfaces are clean and allow adequate time for the Flex-Gel to cure before proceeding with the concrete pour.



Figure 73



Figure 74



Figure 75

On-Slab Fixing

1. Select the correct sized Collar. Ensure a neat fit is achieved with the internal flange extension facing upwards.
2. Ensure the concrete is sound, free of dust and any curing compounds.
3. Wipe clean all surfaces with methylated spirits.
4. Apply NOVITHOR Termite Proof Flex-Gel to the base of the pipe, the internal edge and underneath of the Collar.



Figure 76



Figure 77

Electrical Conduits

Use NOVITHOR Termite Proof Collars around all electrical conduits penetrating the slab.



Figure 78

Horizontal Penetrations

A horizontal penetration is a right-angle insertion into the slab. It usually occurs where a service penetration goes through an edge beam or structural beam. This may allow concealed termite entry through any hollow building materials holding the service penetrations in place (e.g., copper or PVC pipe). All such hollow structures must be replaced or removed before installing NOVITHOR Termite Proof Collars.

Multiple Penetrations

This is where there are several service penetrations that are close to each other. Often these consist of different pipe sizes. NOVITHOR Termite Proof Cementitious Parge may also be used in these cases. Treat each penetration separately. (See next page for details.)

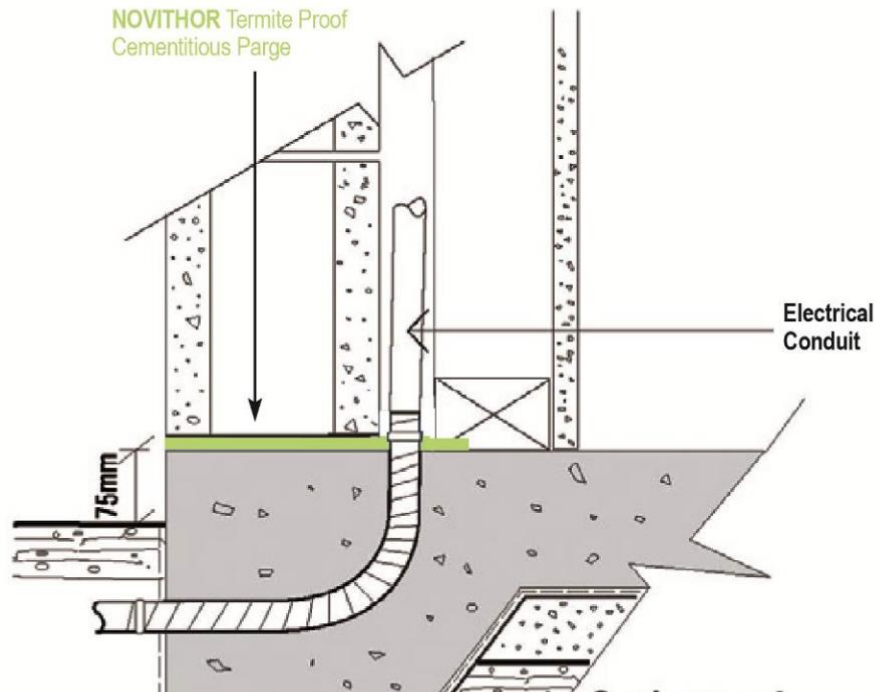

Figure 78

on type 1

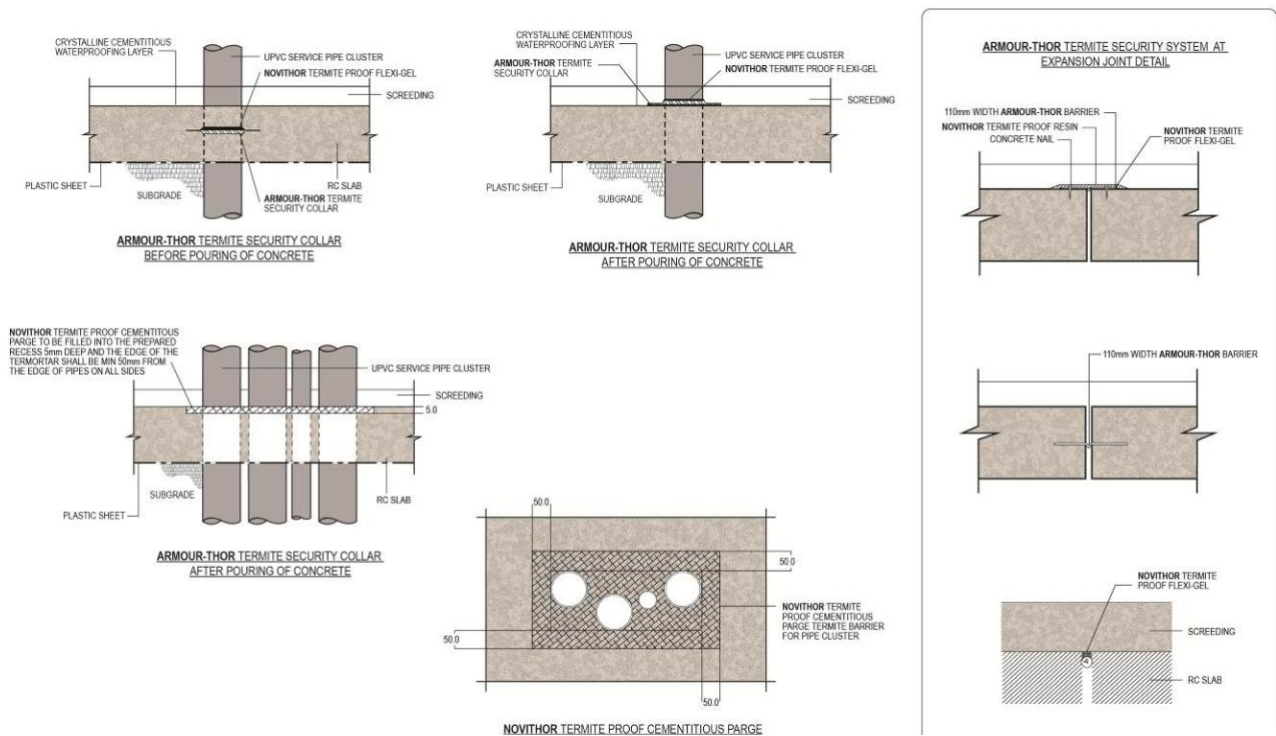

Figure 79

Essential Equipment

Essential Installation Equipment

- ◆ 5 L Stainless Steel Sprayer with Multi-nozzle and 50 cm wand. NB Filters should be removed
- ◆ Xylene for clean-up of NOVITHOR Resin
- ◆ Solvent-safe Funnel
- ◆ 13 mm Backing Rod for vertical brick joints with no foam in them
- ◆ Trim knife to cut back foam when present in vertical brick joints
- ◆ Small square mouth shovel to clean up dropped materials covering the bottom mortar bed if needed
- ◆ Small shifters to dismantle sprayer assembly for cleaning
- ◆ Coarse bristle brush and banister brush to clean any laitance off the concrete substrate
- ◆ Heavy duty applicator/gel gun or sausage gun with trigger to squeeze/push Termite Proof Flex-Gel out of the tube
- ◆ Two putty knives with blades approx. 30-40 mm wide
- ◆ Brick layers trowel
- ◆ 30 m tape measure
- ◆ Hammer and bolster
- ◆ Battery power drill with paddle mixer for mixing NOVITHOR Cementitious Parge
- ◆ Hand towelling or waste rags
- ◆ Plastic buckets
- ◆ Soft bristled broom.
- ◆ Tin snips, straight, left, and right cutting types to cut aluminium.
- ◆ Water should be available on site – if not, provide your own
- ◆ NOVITHOR Meter box stickers

Essential Safety Equipment

- ◆ Hardhat
- ◆ Safety glasses
- ◆ Chemical resistant gloves
- ◆ Hearing protection
- ◆ Overalls
- ◆ Safety boots
- ◆ Portable Eye Wash