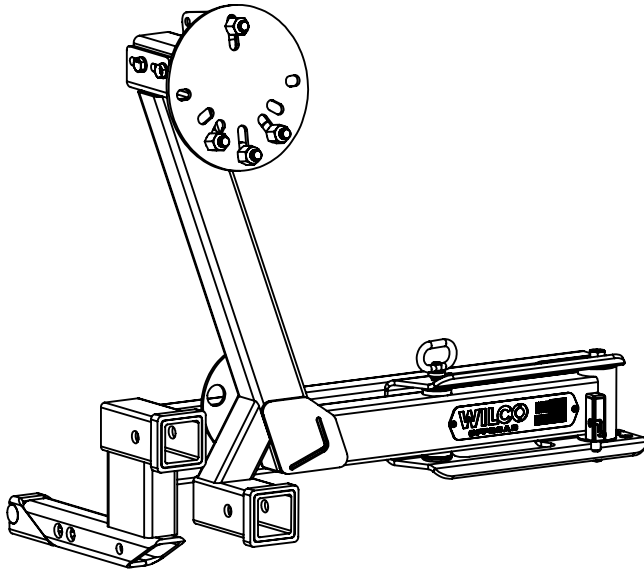

Hitchgate Switch**INSTALLATION GUIDE****Tool List**

- Box wrench set
- Socket set

**Parts List**

1. 1/2-13 x 5 1/2" Bolt	1	10. 1/2-sm Flat washer	3
2. 1/2-13 Ny-Lock nut	1	11. 1/2-md Flat washer	2
3. 1/4 x 3/4 Screw	1	12. M12 Bracket	1
4. 1/4 Flat washer	2	13. 1/4 x 7/8 bolt	2
5. Latch Pin w cable	1	14. 1/4 Ny-loc nut	2
6. 12mm x 40mm Bolt	3	15. 10mm x 100 bolt	2
7. 12mm Lug-Nut	4	16. 10mm flat washers	4
8. Delrin Washer	2	17. 10mm Ny-lock nuts	2
9. Poly-Bushing	2		

Parts assembled with product

1. TireGate Sticker	2	5. 1/2 Loc-washer	1
2. 3" Cap Plug	1	6. Rubber Bumper	2
3. 1/2 x 4" Full Thread	1	7. Wedge Lock	1
4. 1/2 Flat washer	1		

Hitchgate Switch™**Installation Instructions****UHG4100****WARNING**

THE HITCHGATE MUST ONLY BE INSTALLED IN A CLASS III or CLASS V 2" HITCH ASSEMBLY.

Tow vehicles maximum trailer rating may be less then the HITCHGATE's rating, see vehicles owner's guide for maximum towing and tongue weight.

By installing this product you will reduce your vehicles available tongue weight by the weight of the HITCHGATE SWITCH and added weight for example: If the weight of the HITCHGATE SWITCH and your tire weights 200lbs you would reduce your available tongue weight by 200lbs. Refer to your vehicles owners guide and tow hitch for maximum tongue weight and reduce by 200lbs (example: Maximum trailer hitch tongue wt 500 lbs – 200 lbs = 300 lbs maximum trailer hitch tongue weight available after installing this product)

1. **Make sure vehicle is turned off and the emergency brake is set before installing this product.**
2. Remove hitch pin and ball mount.
3. Liberally grease the bolt and anti-rocking wedge-lock on the end of the receiver insert. See Figure 1.
4. Insert The HitchGate wedge-lock assembly into the vehicles receiver pushing it to its maximum depth.
5. Align the HitchGate's hitch pin holes with the receiver's using the hitch pin. See Figure 1. Remove the hitch pin.
6. Tighten the anti-rocking wedge lock using a 3/4" socket and a 12" long extension inserted through the lower 2" tube.
Tighten to approx. 75 ft/lbs. **(See Figure 2.)**

WARNING

THE ANTI-ROCKING WEDGE LOCK IS ONLY TO CONTROL ANY ROCKING MOTION THE HITCHGATE WOULD HAVE WHILE THE VEHICLE IS IN MOTION. THIS IS NOT A SAFETY DEVICE. A HITCH PIN MUST BE INSTALLED SECURING THE HITCHGATE TO THE VEHICLE'S RECEIVER AT ALL TIMES.

7. Reinsert the vehicle's receiver hitch pin.
8. Insert the tire mount swing arm into the HitchGate frame and insert the latch pin through the frame's tabs and the polyurethane bushing. **(See Figure 3.)**
9. Place a black plastic thrust washer on the top and the bottom of the round metal bushing. Grease and then insert the 1/2-13x5 1/2" bolt with 1/2" flat washers on the top and bottom through the bushing and tighten snug. **(See figure 3.)**
10. Pull the latch pin and test the swing of the HitchGate. If it swings too easily, tighten the pivot bolt as necessary. If it takes too much effort to make it swing, loosen the pivot bolt as necessary. (Approx. 35 ft/lbs)
11. Attach the latch pin lanyard to the HitchGate using the supplied hardware. See Figure 4.

Installing the upper lug bracket

12. Mount the M10 Bracket to the top of the Hitchgate Arm.
13. Install the bracket using the 2 – 1/4x20 bolts just snug for now. This will allow you to align the remaining wheel bolts when you mount the tire for the first time.
14. Mount the wheel /tire to the HitchGate tire mount using the supplied hardware. Use a minimum of 3 lug bolts at all times. Full size trucks and SUV's use 4 total lugs.
15. Snug all of the lugs and tighten the 2- 1/4x20 upper bracket bolts to 28 ft lbs.
16. Torque all of the lugs to 75 ft lbs.

Installing the wheel plate to arm assm,

17. Secure the 2 -10mm bolts with washers on each end and torque to 35 ft lbs see **(Figure 1A)**

WARNING

- **THE MAXIMUM SPARE TIRE WEIGHT ON THE HITCHGATE MUST NOT EXCEED 150LBS.**
- **THTE MAXIMUM CARRYING WEIGHT WITH ACCESSORIES IS 150LBS**

WARNING

- **THE WHEEL/TIRE MUST BE SECURED TO THE HITCHGATE WITH THE SAFETY CABLE AT ALL TIMES.**
- **AFTER DRIVING THE VEHICLE 25 MILES RE-TORQUE THE WHEEL LUGS TO 75 FT LBS.**
- **CHECK THE LUGS DURING YOUR SCHEDULED OIL CHANGES.**

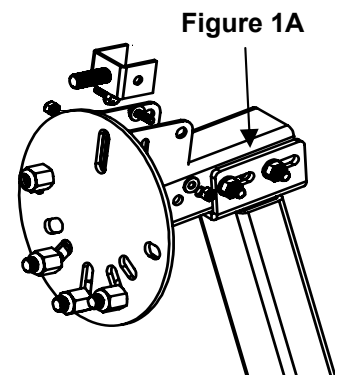

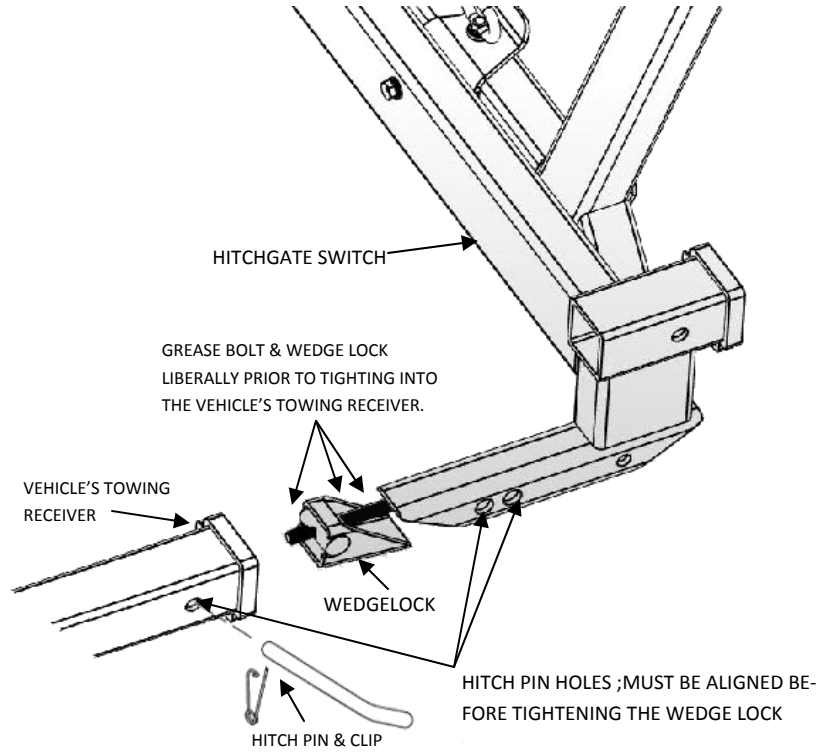

Figure 1. Grease wedge-lock before inserting into receiver.

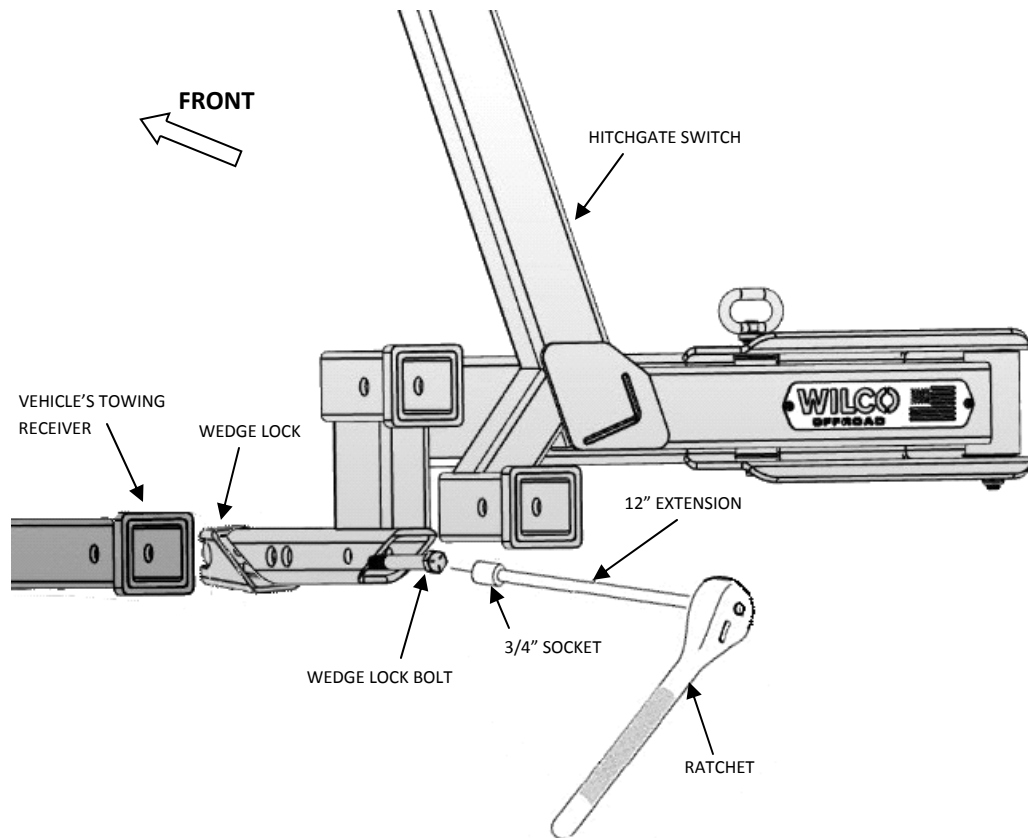

Figure 2. Tighten the wedge-lock bolt to 75 ft/lbs.

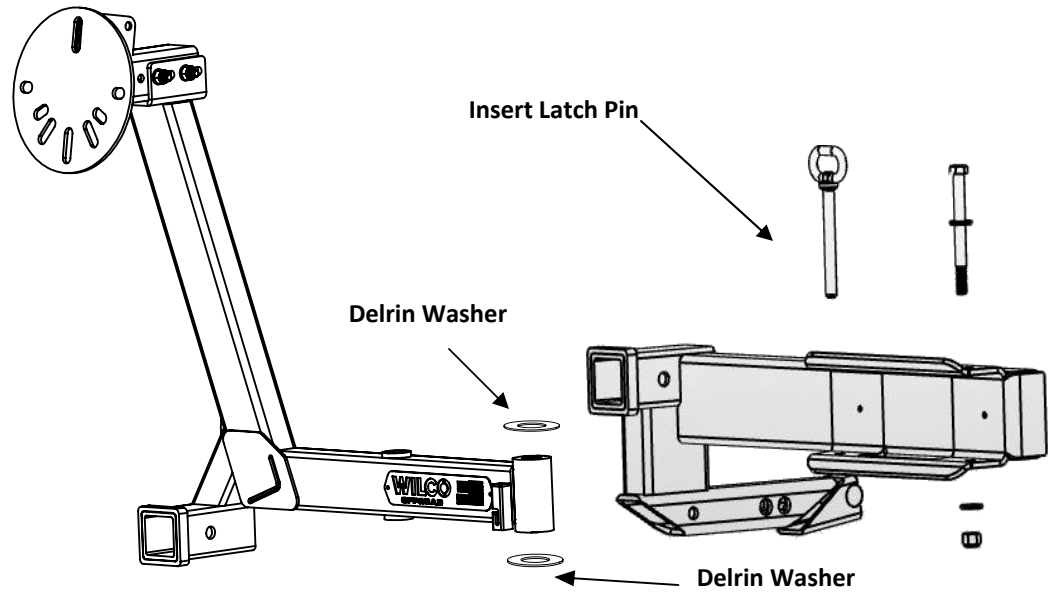

Figure 3. Mounting HitchGate Swing Arm to Receiver Arm

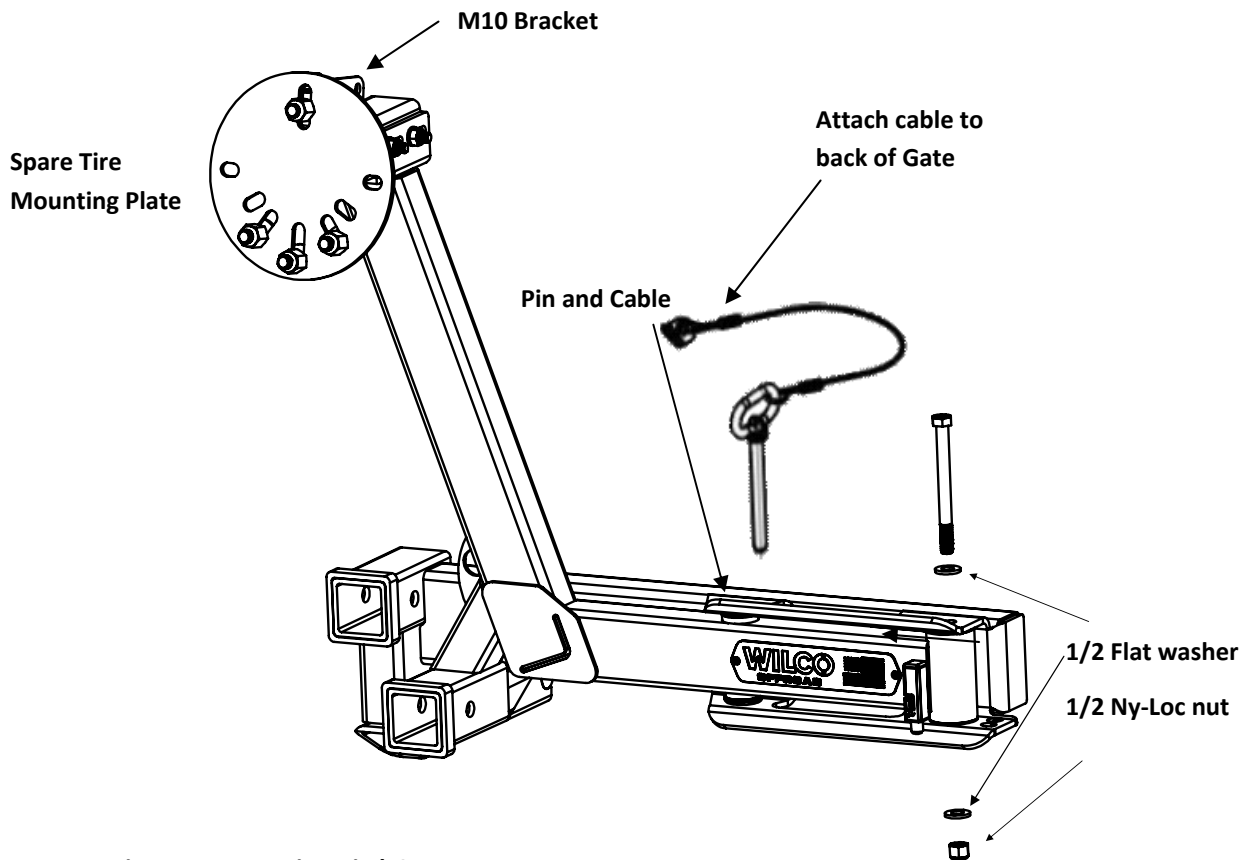

Figure 4. Mounting HitchGate