

ADV CHASE RACK INSTRUCTIONS

Tool List

- Metric Socket Set
- Metric Wrench Set
- 4mm Allen Wrench
- Heavy Blanket / Towel

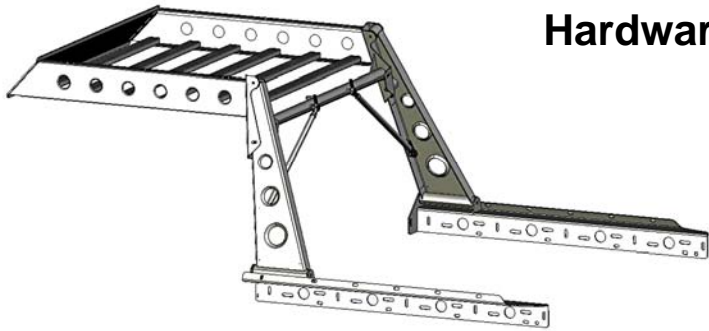

Hardware

RISER HARDWARE

- 1. 1/2-13x12" 2
- 2. 1/2" Washer 4
- 3. 1/2-13" Nylock nut 2

CROSS BARS

- 9. 3/8 x 1.5" Carriage Bolt 12
- 10. 3/8-16 Nylock nut 10
- 11. 3/8" Washers 26

OUTRIGGER HARDWARE

- 4. 10mm-1.5 x 110mm 2
- 5. 10mm-1.5 x 90mm 6
- 6. 10mm-1.5 x 50mm 2
- 7. 10mm-Washers 20
- 8. 10mm-Nylock Nut 10

WIND FAIRING

- 12. 1/4 x 7/8" Bolt 4
- 13. 1/4" Washer 8
- 14. 1/4" Nylock Nut 4

Please read before starting installation:

- * Cover roof of vehicle with a protective blanket
- * Inspect all components and verify all hardware is correct, present, and free of damage.
- * Be mindful of scratching/damaging the powder coating while installing or using the rack, exposed metal will rust.
- * 2 person installation is recommended. If you are unsure of the installation process, we recommend professional installation at your local installer or shop.
- * Be aware that when installed, it will add additional height to your vehicle. Vehicles may no longer fit in garages, drive-thrus, or parking structures. Measure your vehicle's total height before attempting to enter one.
- * Wait to tighten bolts until the entire rack is assembled, then tighten from the top down to ensure proper alignment. Double

- 1. Bed Rail 2
- 2. Riser 2
- 3. Protective cloth
- 4. Outrigger 2
- 5. Height Adjustment Bolt 1
- 6. Rear Cross Tube 1
- 7. Cross Bars (Cargo Bars) 6
- 8. Wind Faring 1
- 9. Threaded bump stop 2
- 10. Bed Turnbuckles 2
- 11. Headache Heim Rod 2
- 12. Bed Mounting Clamps 4
- 13. Cargo Track Mounts 6

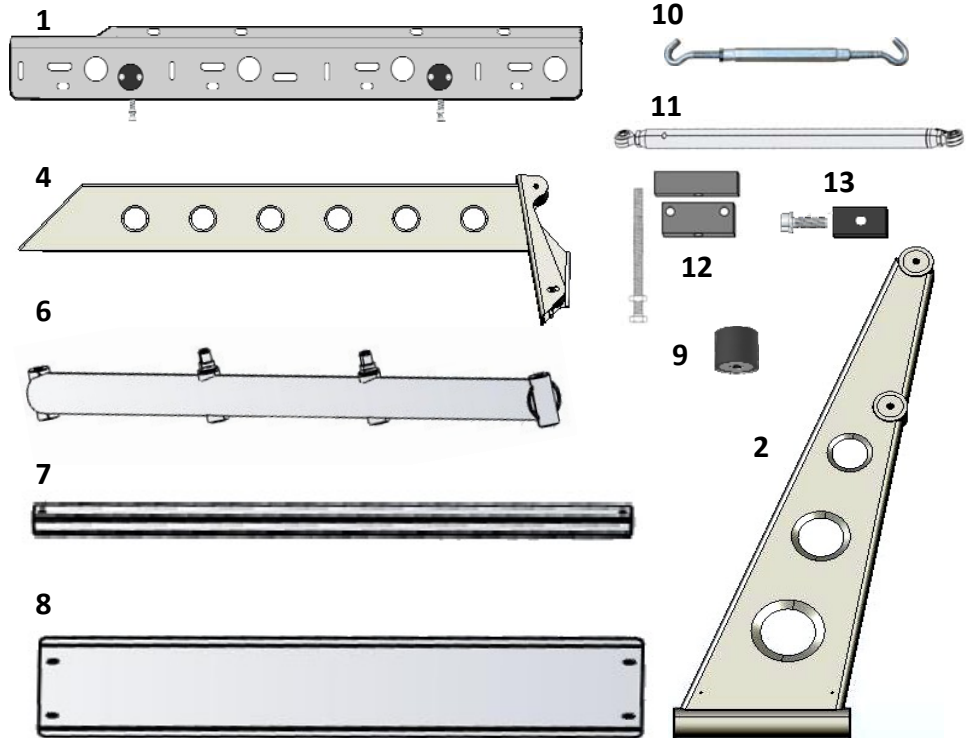

Step 1: Choose the type of install for your Bed Rails:

1. Install the ADV Bed Rail to the vehicles bed using either option 12 or 13 below, do not tighten at this time .

**OPTION 12 : Under
Bedrail Mounting**

- Threaded Clamp Block 4
- M10 x 100 Full Thread 4
- M10 std Nut 4
- 1/4 x 1" Allen Bolt 8
- Round Face Plate 4

OPTION 12 Universal Bed Clamp Kit

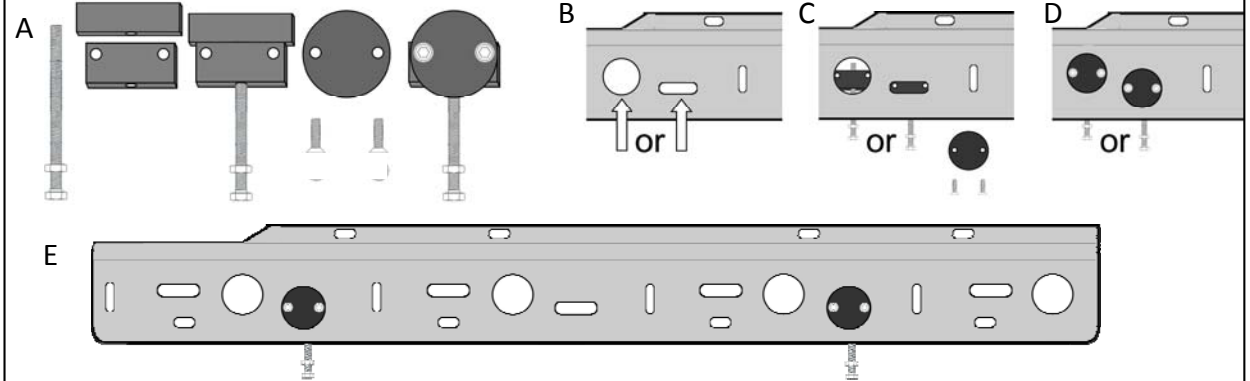

**OPTION 13 : Cargo
Track / Uni-Track
Mounting**

- Threaded Track Slider 6
- Flange Bolts M10-40 6

OPTION 13 Cargo Track Rail

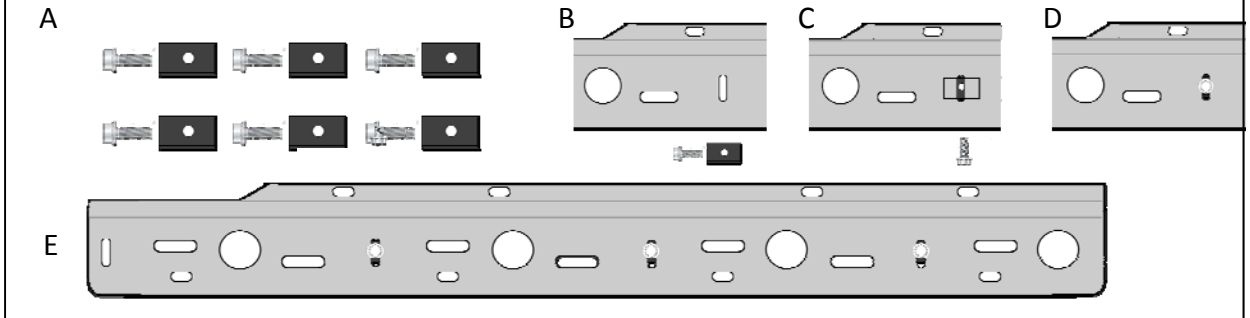

Step 2: Install RISERS

1. Using a 12" x 1/2" bolt, washers and Nylock nut
2. Assemble the Riser to the installed Bed Rail (Fig 2)
3. Lean Riser away from vehicle, tuck a protective cloth between Riser (#2) and Bed Rail (#1) to prevent damage to coating or truck.

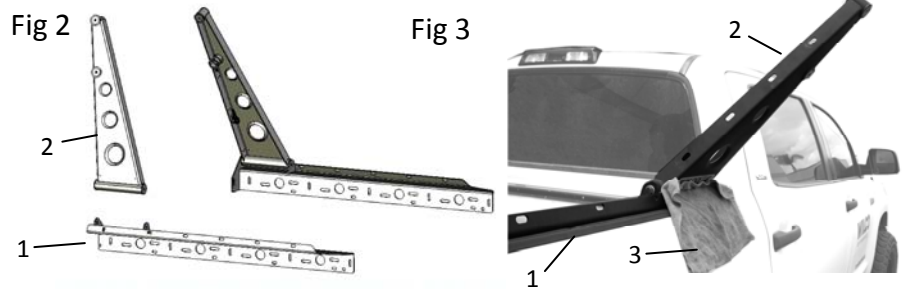

Step 3: Install OUTRIGGERS

1. Using M10X80mm bolts, attach the Outrigger (#4) to the Riser (#2) at the top bushing at 12 o'clock position. (Fig 4)
2. Rotate the Outrigger (#4) downward to line up with the lower bushing in the Riser (#2) and install M10 x 90mm bolt. (Fig 5)
3. The Outrigger (#4) is designed to be a snug fit to prevent rattling.
4. Install the m10 x 50mm bolt into the welded nut on the Riser (#2) to support the Outrigger (#4) at the desired Height.

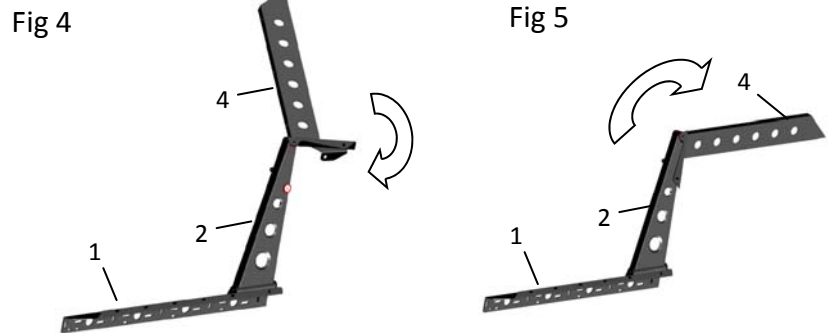

Step 4: Install Cross Tube and Bars:

1. Using 3/8" x 1.5" bolts, attach the Rear Cross Tube (#6) between the two Risers (#2) (Fig 6)
2. Install 3/8" carriage bolts UPWARD through the Outriggers (#4) though the Cross Bars (#7) secure with 3/8" Nylock nuts, Do not tighten yet. (Fig 7)
3. Install the Bump Stop (#9) to the furthest forward cross bar. Install a 3/8 x 1.5" Carriage bolt downward first through the Cross Bar (#7) through the Outrigger (#4) into the Threaded Bump Stop (#9) twist the Bump Stop to tighten the assembly together. (Fig 8)
4. **IMPORTANT:** The bump stops protect the Rack from striking the vehicle.

NOTE: Bump Stops should NOT be resting on the cab of the vehicle.

Fig 6

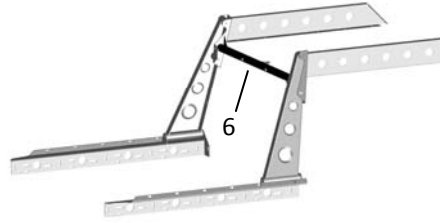

Fig 7

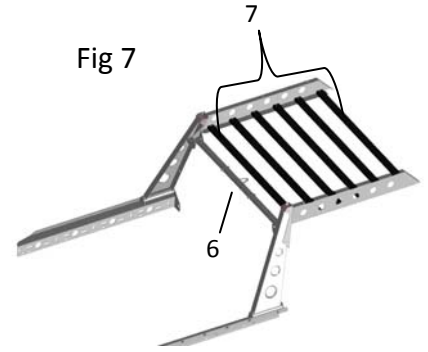
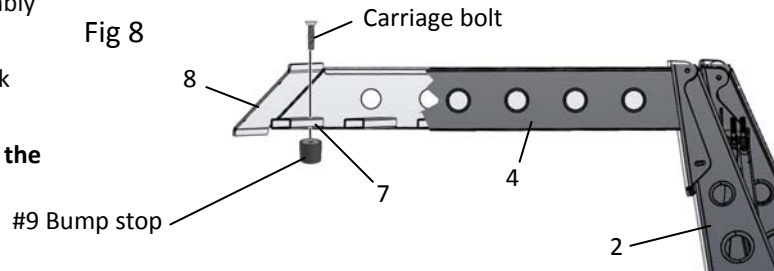

Fig 8



Step 5: Install Wind Faring:

1. Using 1/4" bolts, washers & nuts, fasten the wind-faring (#8) onto the front of the outriggers (#4) (Fig 9)

Fig 9

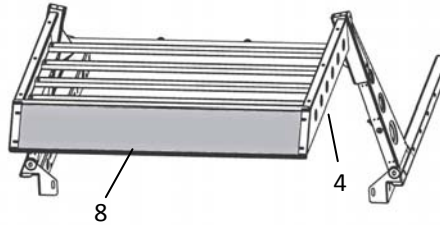
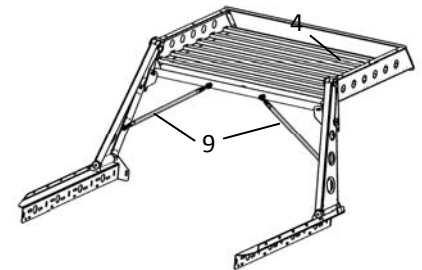

Fig 10



Step 6: Install Heim Rods:

1. Using m10 x 110 bolts, attach the Heim Rods (#9) to the welded Rear Cross Tube (#6)
2. Using m10x50mm bolts attach the other end of the Heim Rods to the Risers (#2)
3. Tighten Jam nuts on Heim Rods

Step 7: Install Bed Rail to Bed Turn Buckles:

1. Install the Turn Buckles (#10) to your existing bed anchor location.
2. Find a rear anchor location in your lower back corner truck bed and hook one end of the Turn Buckle (#10) to the anchor location. The other end to the Bed Rail (#1).
3. Adjust the Turn Buckle (#10) hand tight, then using a 5/8" wrench turn in an additional 1/2 turn to secure.
4. Tighten Jam nut once turn buckle is snug.

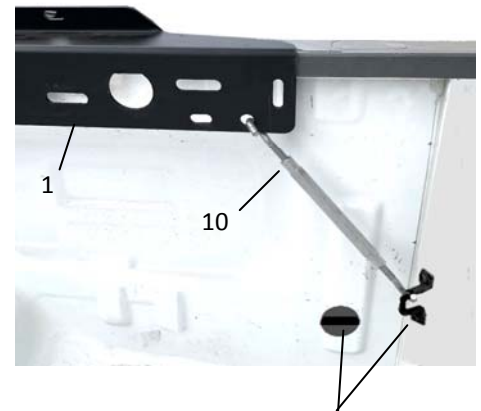

Existing bed anchors