

SEASONAL SCENES OF JAPAN

Gold fish

Assembly Instructions



By assembling all parts referring to the symbols on the parts sheet and the assembly instructions, a paper craft model faithfully reproducing the "Gold fish" is completed.

- **Assembly instructions: Ten A4-sized sheets.**
- **Paper craft: Six A4-sized sheets with 45 parts in all**

These **Assembly instructions** apply only to the "Gold fish."

Please download the parts sheets separately.

These Paper Craft parts are easier to work with when printed out on strong, thick paper (Paper Weight in gsm: 127.9gms ~ 157.0gms, Thickness: 0.18mm ~ 0.22mm)

Note: The copyright of this paper craft belongs to MUKOUYAMA KU-KAN.



This paper craft is intended for personal enjoyment. The contents of the Paper Crafts (net drawing and instructions and assembled finished model), including the designs, text, and images, may not be quoted, reproduced, used, copied, distributed, modified, or sold without the permission of the author. However, please refrain from posting or exhibiting paper crafts for commercial purposes, such as explaining how to make paper crafts to the general public, or posting videos or images of paper crafts. These terms and conditions are deemed to be agreed upon upon opening the file. You are also deemed to have agreed to the terms of use and violations of the MUKOUYAMA KU-KAN website.

1 To begin

■ Tools and materials needed

●Ruler ●Scissors ●Cutter knife ●Cutter mat (A4 size or larger) ●Stylus pen (for making folds) ●Pencil ●Tweezers ●Quick-drying wood glue (adhesive) ●Brush (for glue) ●Wipe cloth (to wipe off excess glue from the brush) ●Wipe cloth (to wipe off excess glue from brush) ●Hand towel to clean fingertips ●Acrylic board and weight (to ensure a level crimp) ●Aluminum rod(to round the paper) ●Containers (for temporary storage of parts) ●Memo blocks (to use as a palette for applying glue to brushes)

■ Items of Caution

*Take care when using sharp or pointed objects or when using bladed cutting tools. Place a heavy sheet of paper under the paper you want to cut.

*Use glue and other adhesives only in well-ventilated areas.

*When printing, use a slightly reduced font size. There may be differences in dimensions, depending on the type of printer used.

2 How to assemble

*Follow the working method and markings carefully.

*Cut carefully along the outer line with cutting blade, Exacto-knife or scissors.

One - point Advice

*Cut carefully with cutting blade, Exacto-knife or scissors.

*For folding parts, first use an awl or other pointed tool to make a light crease along the dotted or solid line. This will make the folds straight. Avoid making strong creases, as this will cause the paper to tear.

*As an adhesive, white wood glue is recommended. Avoid over application as this may cause the paper to wrinkle.

*Before beginning assembly, test adhesive amounts on extra paper.

Basic working method and markings

————— Solid lines

Fold along these lines.
The printed surface should be on the outside of the folded shape.

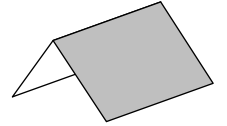

----- Broken lines

Fold along these lines.
The printed surface should be on the inside of the folded shape.

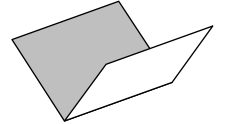

----- Dotted line

Cut along these lines.

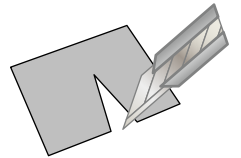

Do not fold or cut the parts marked X.

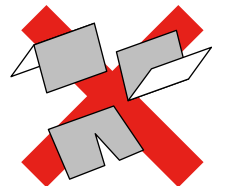

Cut out parts marked with an asterisk(*).

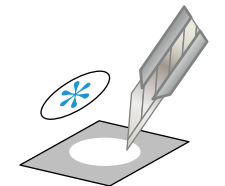

Red dots are the reference positions for gluing surfaces.

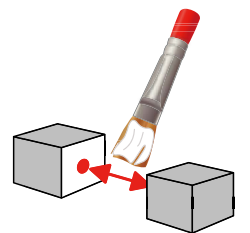

*Please refer to the MUKOUYAMA KU-KAN website TECHNICAL for details on the crafting method.

3 Assembly

Please refer to the "Basic working method and markings" symbol chart on Page 2 to assemble each part.

Indication of Working Methods

Fold or Curve Glue

Goldfish

1. Assembly of Head Fold each relevant part according to the assembly symbols.
Please use the ● dots on each component as reference when gluing surfaces.

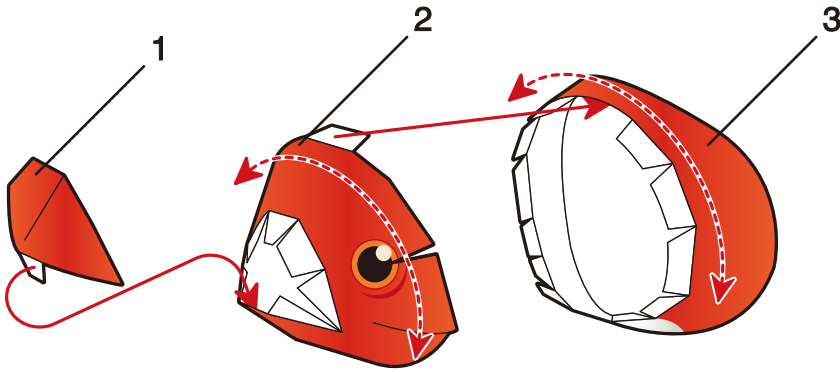

Reference photo



2. Assembly of Body1 Assemble according to steps ① through ④ .

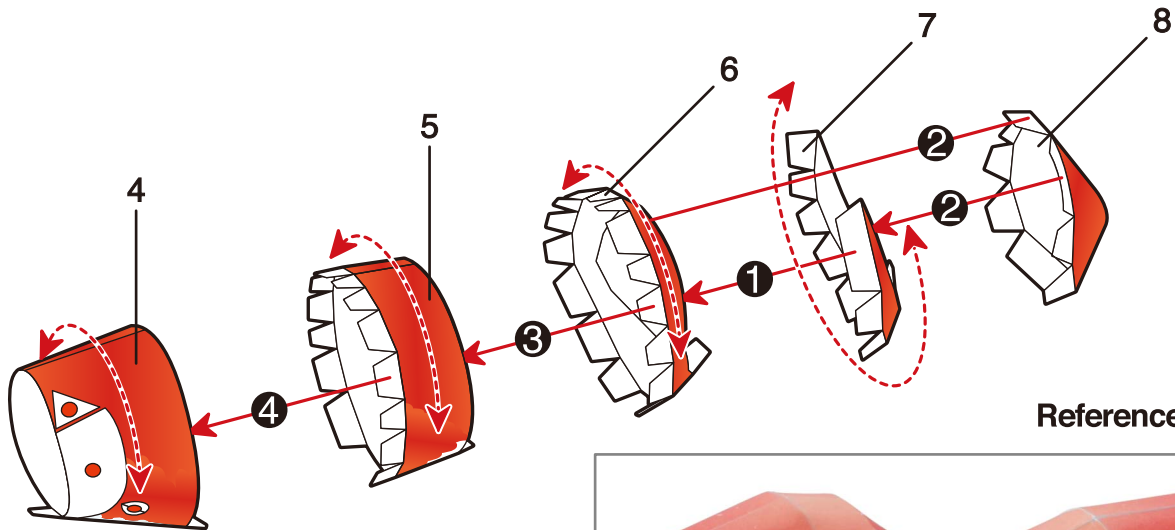

Reference photo



3 Assembly

Please refer to the "Basic working method and markings" symbol chart on Page 2 to assemble each part.

Indication of Working Methods  Fold or Curve  Glue

Goldfish

3.Assembly of Body2 Fold each relevant part according to the assembly symbols.
Please use the ● dots on each component as reference when gluing surfaces.

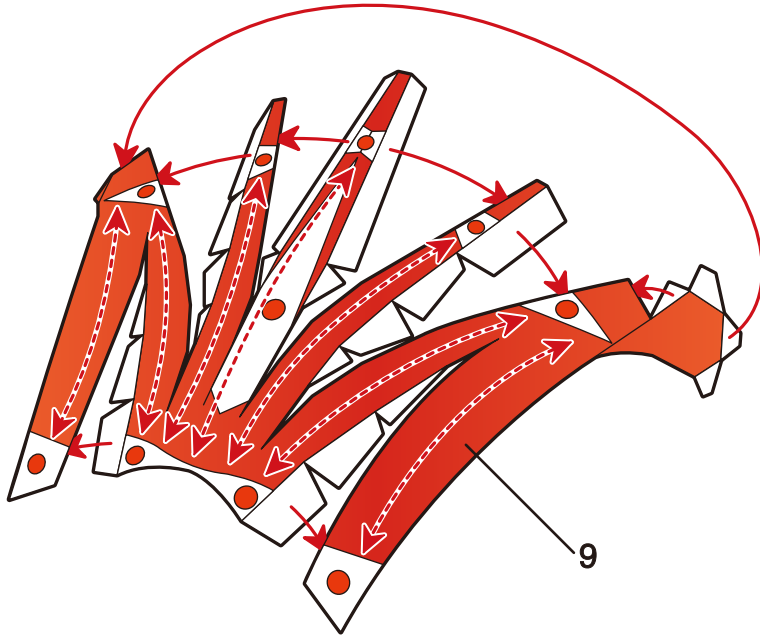

Reference photo



4.Assembly of Flippers1

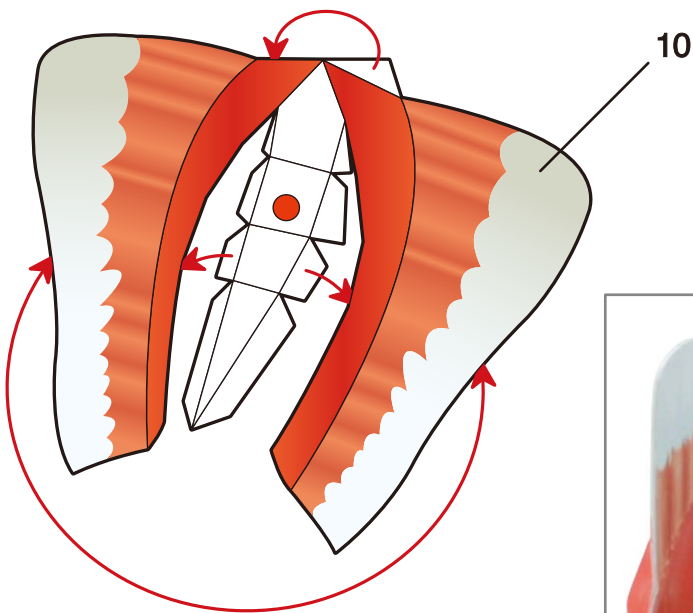

Reference photo



3 Assembly

Please refer to the "Basic working method and markings" symbol chart on Page 2 to assemble each part.

Indication of Working Methods

 Fold or Curve  Glue

Goldfish

5. Assembly of Flippers2~4

Fold each relevant part according to the assembly symbols. Please use the ● dots on each component as reference when gluing surfaces.

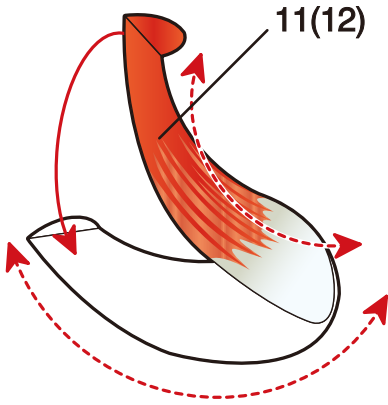

Reference photo

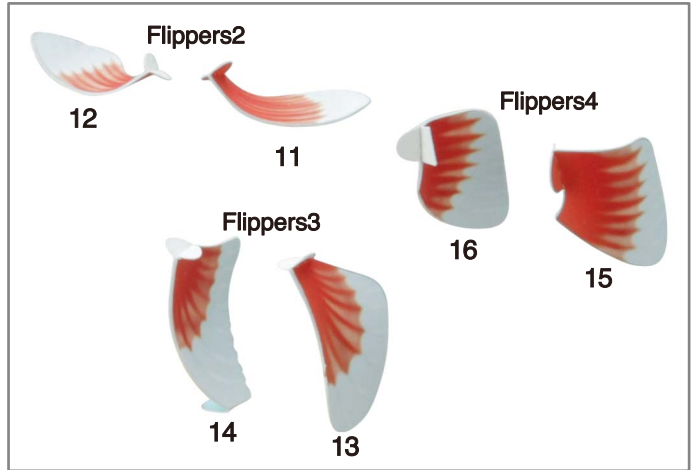

6. Assembly of Flippers5

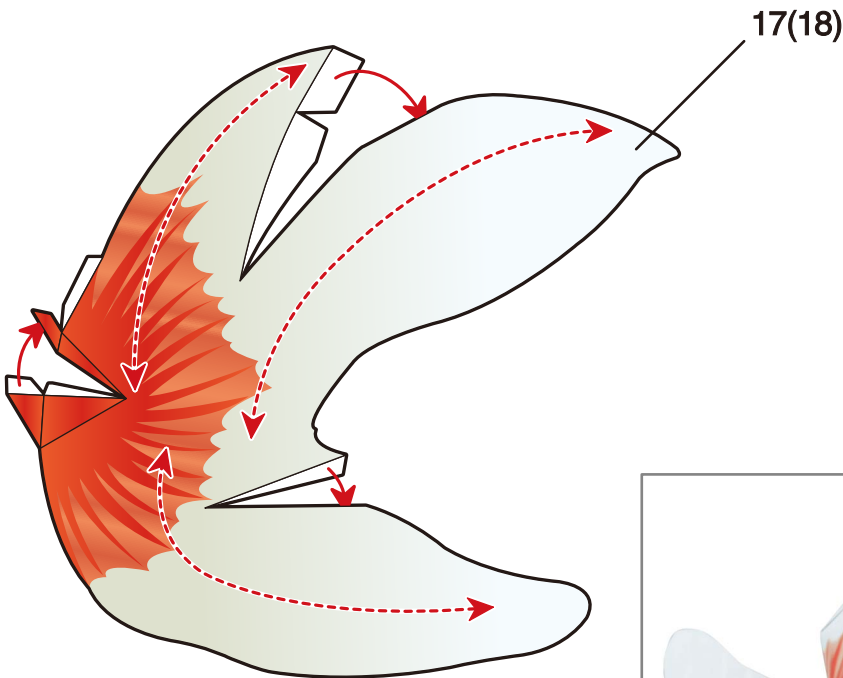

Reference photo



3 Assembly

Please refer to the "Basic working method and markings" symbol chart on Page 2 to assemble each part.

Indication of Working Methods  Fold or Curve  Glue

Goldfish

7. Assembly of Goldfish

Fold each relevant part according to the assembly symbols.

Please use the ● dots on each component as reference when gluing surfaces.

Assemble according to steps ① through ⑥ .

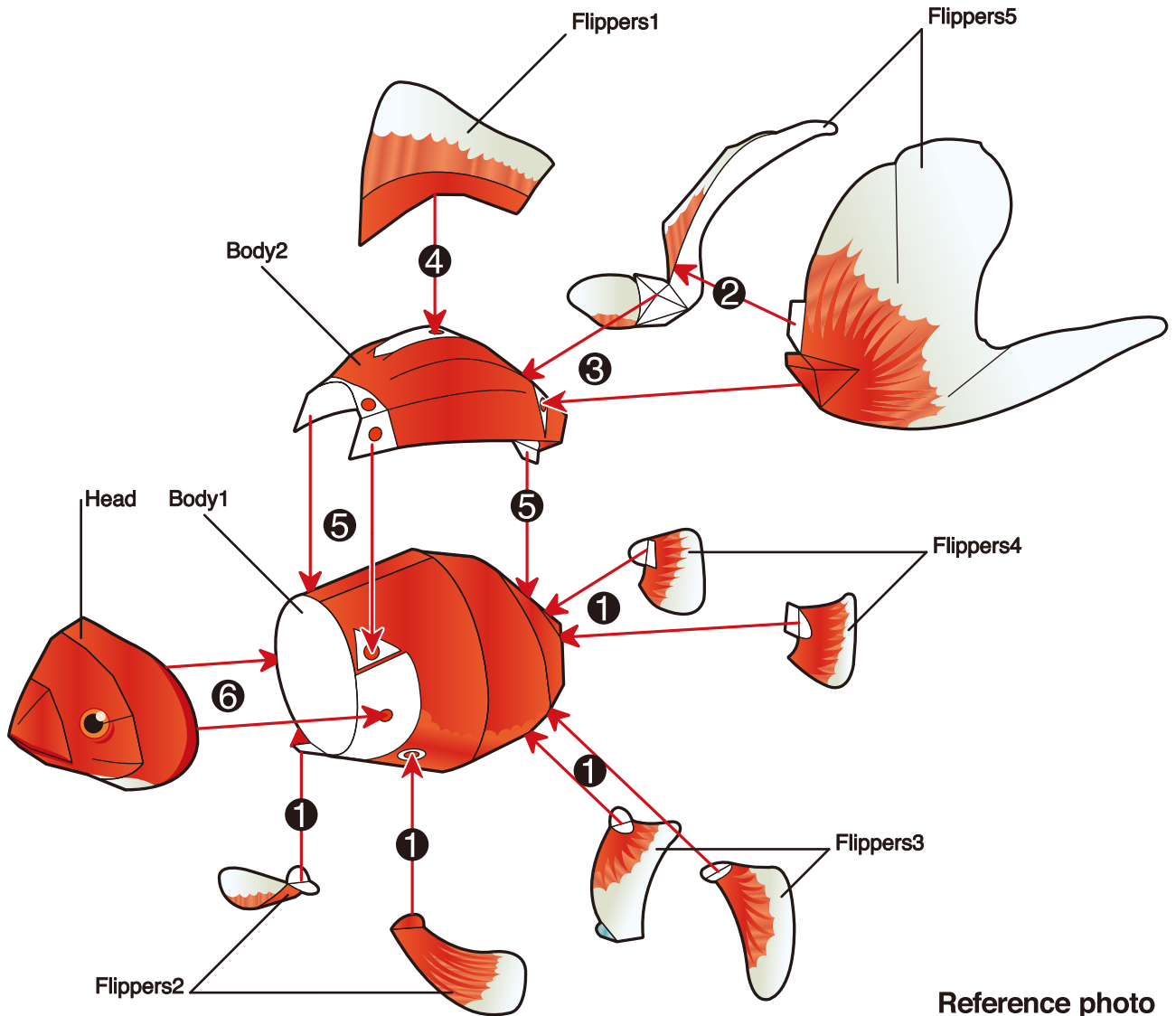

Reference photo



3 Assembly

Please refer to the "Basic working method and markings" symbol chart on Page 2 to assemble each part.

Indication of Working Methods



Fold or Curve



Glue

Goldfish

8. Assembly of Water Plant

Fold each relevant part according to the assembly symbols.

Please use the ● dots on each component as reference when gluing surfaces.

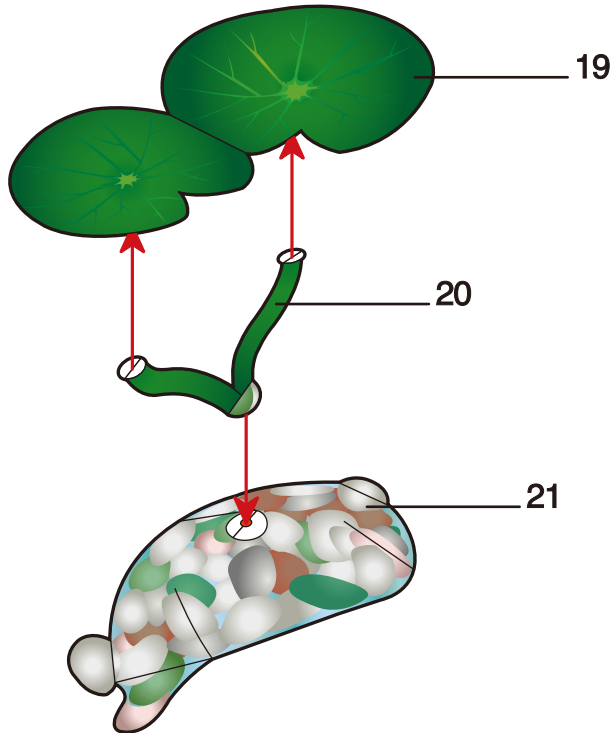

Reference photo



9. Assembly of Basin1

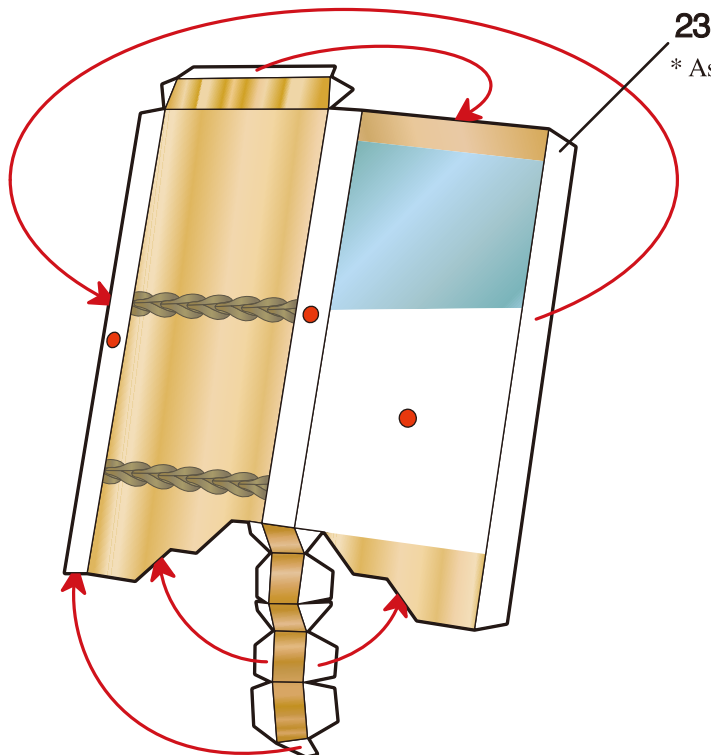

23

* Assemble items 24 to 41 in the same manner.

Reference photo



23

22

3 Assembly

Please refer to the "Basic working method and markings" symbol chart on Page 2 to assemble each part.

Indication of Working Methods  Fold or Curve  Glue

Goldfish

10. Assembly of Basin²

Fold each relevant part according to the assembly symbols.

Please use the ● dots on each component as reference when gluing surfaces.

Assemble according to steps ① through ③ .

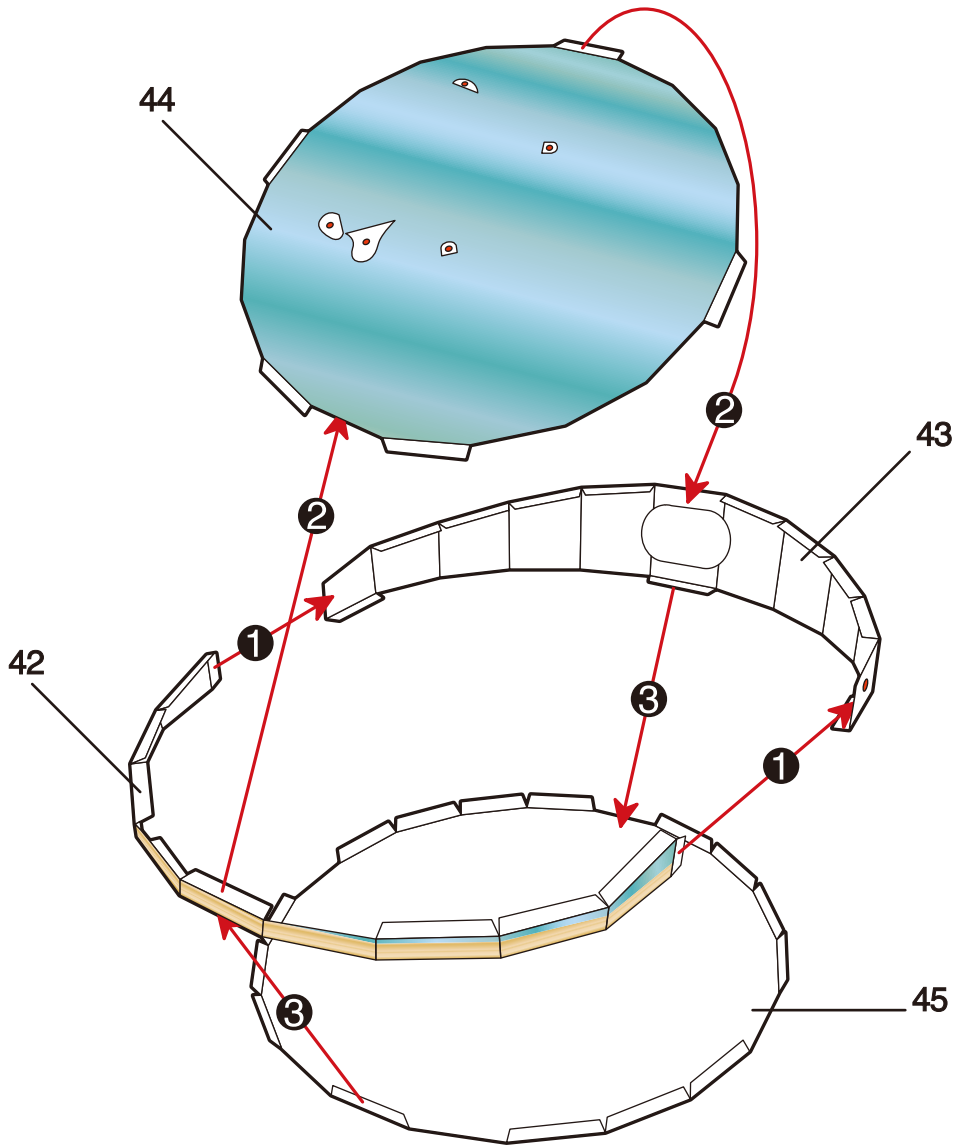

Reference photo



4 Completion

Connect each of previously assembled parts in order. Indication of Working Methods ---→ Fold or Curve → Glue

Goldfish

11. Finish Please use the ● dots on each component as reference when gluing surfaces.

Assemble according to steps ① through ⑥ .

Procedure

- | | |
|-----------------------------------|------------------------------------|
| ① Glue Goldfish to Basin 2. | ④ Glue Basin 1 to Basin 2. |
| ② Glue Water Plant to Basin 2. | ⑤ Glue the Water Plant to Basin 1. |
| ③ Glue parts of Basin 1 together. | ⑥ Glue to Basin 2 if desired. |

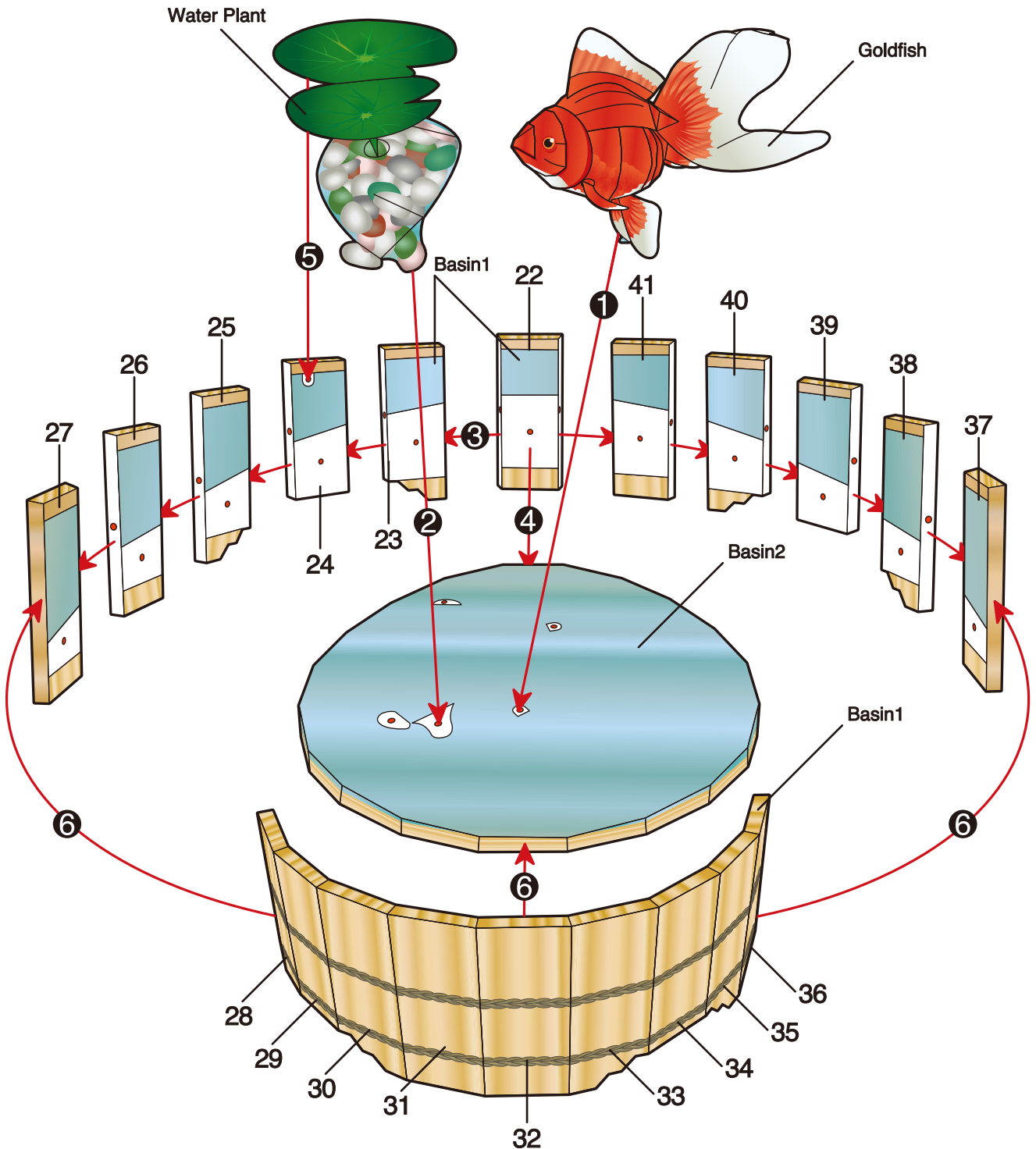

5 Assembled Model

Here are pictures of the completed models. Please refer to them when assembling.

