



TM-10K

10,000 LBS. CAPACITY WINCH

Installation & Operator's Manual

SAFETY WARNINGS

LEARN THE USAGE OF YOUR TM WINCH:

Once the winch has been properly installed, take the opportunity to practice using it, ensuring you become familiar with ALL OPERATIONS. It's recommended to periodically inspect the winch installation to confirm that all bolts remain securely fastened. Before engaging the winch, carefully examine all components for any signs of damage to ensure optimal performance.

MAINTAIN A CLEAR WINCHING AREA:

During winching operations, it's crucial to ensure that no individuals are present in the immediate vicinity. Crossing over a taut synthetic rope, or allowing others to do so, is strictly prohibited. Due to the potential hazard of synthetic rope breakage, maintain a safe distance from any potential path. A snapped synthetic rope can cause serious harm or even death. Always maintain a stable stance and equilibrium. Avoid reaching over or across the winch, as well as pulling synthetic rope, while the winch is active.

FREQUENT INSPECTION OF SYNTHETIC ROPE AND EQUIPMENT:

Regularly assess the condition of the synthetic rope for any signs of damage that could compromise its breaking strength. If you detect a frayed steel cable or synthetic rope with broken strands, replace it promptly. Always substitute with a synthetic rope that is rated to withstand the load capacity of the winch. Any replacement must precisely match the strength, quality, lay, and stranding of the original Mile Marker steel cable or synthetic rope.

OBSERVE WORKING AREA CONDITIONS:

Ensure proper illumination of the working area. Avoid using the winch in the presence of flammable gases or liquids.

KEEP CHILDREN AT A DISTANCE:

For safety reasons, keep children away from the working area and prohibit them from operating the winch.

ADHERE TO APPROPRIATE ATTIRE:

Avoid wearing loose clothing or jewelry that could become entangled in moving parts. When operating the winch, only use protective, electrically non-conductive clothing and non-skid footwear. Wear a secure hair covering to confine long hair.

UTILIZE GLOVES:

When handling or rewinding the synthetic rope, always wear protective gloves to prevent cuts.

CHECK THE DRUM:

Before winching, ensure there are at least 8 complete turns of synthetic rope left on the drum.

EXERCISE CAUTION WITH HANDS AND FINGERS:

Keep your hands and fingers clear of the synthetic rope, and hook while operating the winch. Never insert your finger through the hook while reeling in the last few feet, as it could lead to severe injury. Avoid guiding a tensioned synthetic rope onto the drum using your hand.

AVOID HOOKING THE ROPE ON ITSELF:

Refrain from hooking the synthetic rope back onto itself, as this places excessive strain on individual strands, weakening the entire rope.

LIMIT PULLING DURATION:

The winch is designed for intermittent use and should not be used for constant duty applications. Avoid pulling at or near the rated load for more than one minute. If the motor becomes overly hot to the touch, allow it to cool before resuming use. If the motor stalls, immediately cut off power.

PREVENT OVERLOADING:

Always operate the winch within its rated capacity for safety and optimal performance. Do not attempt to exceed its capacity by using inappropriate attachments.

AVOID EXTREME ANGLES DURING PULLS:

To prevent bunching of the synthetic rope on one end of the drum, avoid continuous pulls from extreme angles. The rope should remain as straight as possible in relation to the direction of the object being pulled. No more than 15 degrees up and down and 45 degrees left and right.

USE THE WINCH WITH THE FAIRLEAD:

To prevent operator injury and potential winch damage, ensure the fairlead is properly installed before operating the winch.

STAY ATTENTIVE:

Remain focused on your actions and utilize common sense. Refrain from operating the winch when fatigued, stressed, or under the influence of drugs, alcohol, or medication.

DISCONNECT HAND REMOTE:

When not in use, unplug the hand remote to prevent unintended activation.

REPLACEMENT PARTS AND ACCESSORIES:

During maintenance, only use identical replacement parts to avoid voiding the warranty. Approved accessories can be obtained from your local distributor.

CLUTCH OPERATION:

Do not force the clutch. Rotate the drum to align gears for free spooling

SAFETY GUIDELINES FOR OPERATING YOUR WINCH

- Keep hands and body away from the roller or hawse fairlead (intake slot for synthetic rope) while the winch is in operation.
- Ensure the vehicle is securely positioned before using the winch.
- Never exceed the winch's load weight capacity.
- Confirm that the winch is securely bolted to a structure or vehicle capable of handling the intended load.
- Always use appropriate couplings when connecting the winch steel cable/synthetic rope hook to the load.
- Avoid lifting items vertically; the winch is designed for horizontal use only.
- Never overload the winch; it performs optimally within its intended load range.
- Do not attempt to lift people or hoist loads over individuals.
- Keep clear of the area between the winch and the load while operating.
- Avoid applying a load to the winch when the synthetic rope is fully extended. Maintain a minimum of 8 wraps of synthetic rope on the drum.
- After moving an item with the winch, ensure the item is properly secured. Do not rely on the winch to hold it for extended periods.
- Prior to use, inspect the winch for any effects from exposure to weather, chemicals, salts, and rust.
- Do not fully extend the synthetic rope while under load. Always maintain 8 wraps of synthetic rope around the winch drum.
- Do not operate the winch if the synthetic rope shows signs of weakening, knots, or kinks.
- Avoid crossing over or under the synthetic rope while it is in the process of loading.
- Never move a vehicle with the synthetic rope extended and attached to a load for pulling purposes, as this could result in damage to winch and rope.
- Always respool the synthetic rope properly to ensure safe and effective future use.

GETTING STARTED

Winch Mounting

NOTE: Mile Marker emphasizes the utilization of its proprietary mounting systems to facilitate the correct installation of the winch, thereby ensuring the realization of its peak performance capabilities. If a non-Mile Marker mounting system is opted for, it is imperative to conduct a thorough evaluation of the chosen mounting platform's structural robustness. This evaluation aims to ascertain its capacity to effectively withstand the maximum rated load of the winch.

To meet these stringent requirements, Mile Marker advocates for the implementation of mounting platforms crafted from durable materials such as steel plates. These plates should possess a minimum thickness of 0.25 inches with reinforcement bends, guaranteeing the requisite strength and stability for the mounting platform. Adhering rigorously to these guidelines serves as an assurance of the winching system's reliability and resilience, even when subjected to demanding operational scenarios.

For optimal performance and safety, it is essential to affix the Mile Marker winch onto a robust section of the vehicle (either the front or rear), ensuring uniform distribution of the entire rated load.

CAUTION: It is of paramount importance that the mounting surface is perfectly level, and the winch is installed in a manner that ensures the correct alignment of its three key sections: the gear housing end, the drum, and the motor end.

1. When deemed necessary, create four mounting holes with a diameter of 10mm, arranged in a pattern of 6" x 4.5".
2. Secure the winch body onto the mounting platform by utilizing the provided four screws, along with washers and spring washers. Refer to the parts breakdown and assembly instructions specific to each winch model.
3. Apply a torque of approximately 35 ft-lb (47.5 N-m) to tighten the capscrews securely.
4. All Mile Marker mounting systems are outfitted with pre-drilled fairlead holes. In the case of employing an alternative mounting platform, it is imperative to drill two holes to accommodate the installation of the roller fairlead. Position these holes so that the fairlead opening aligns from the circumference of the drum to the extremity of the maximum allowable layers on the drum, following the direction in which the rope is wound.
5. When substituting the cap screws or when necessitating longer bolts, ensure the utilization of bolts with a grade of 8 or higher.

CLOCKING INSTRUCTIONS

Winch gear housing can be clocked in 8 positions, enabling the user to position the clutch lever at 8 equidistant locations (0°, 45°, 90°360°). (Fig. 1-1)

1. Remove gear housing from tie bars (Fig. 1-2)
2. Remove the 8 bolts in the gear housing leg (Fig. 1-3)
3. Separate leg and gear housing. A slight tap with a hammer might be needed (Fig. 1-4)
4. Place gear housing leg in the angle desired and screw in bolts (Fig. 1-5) Torque to spec
5. Properly slide drive shaft in the gear housing and line drum into drive gear (Fig. 1-6)
6. Re-attach tie bars to gear housing leg by using the same process as step 1, in reverse order (Fig. 1-2)

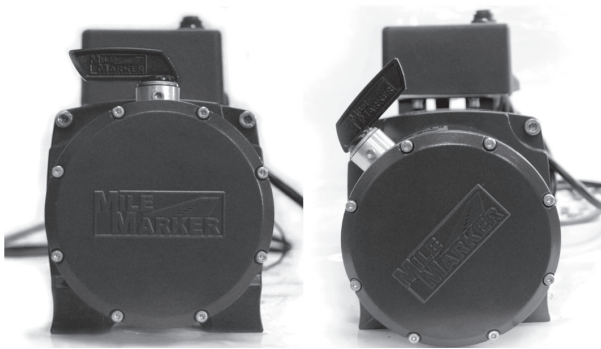

Fig. 1-1



Fig. 1-2

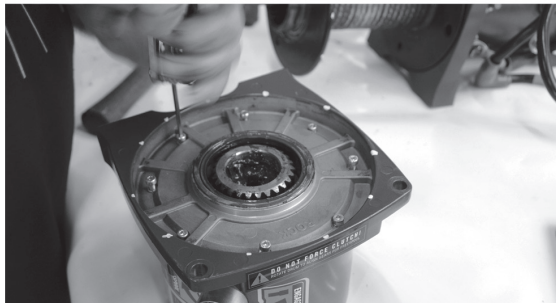

Fig. 1-3



Fig. 1-4

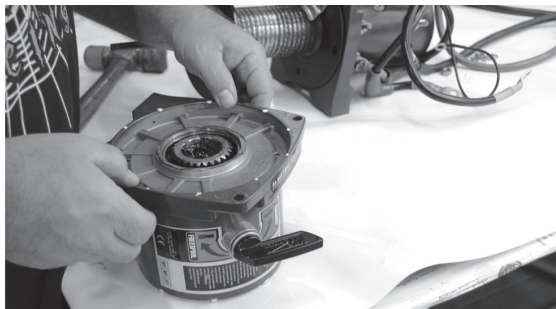

Fig. 1-5

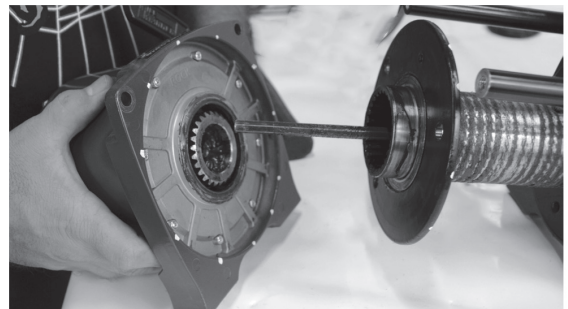

Fig. 1-6

CONTROL BOX INSTALLATION

NOTE: For best results, Mile Marker recommends mounting the control box to the winch, either over the motor or over the tie bars. If you choose to mount the control box within your vehicle, ensure that the location does not interfere with any moving or functioning parts of your vehicle and that electrical cables with similar specifications to Mile Marker's are used.

Tools Required for Control Box Installation

1. Wrenches: 14mm, 10mm, metric Allen wrench set, pair of snips
2. General hand tools

Mounting Control Box on Motor

If you choose to mount your control box on the winch motor, please follow the following steps

1. Mount the control box to mounting brackets using 10 mm wrench (Fig 2-2 & 2-3)
2. With mounting bracket attached to control box, locate the mounting points on the side of the motor die casting (Fig. 2-4)
3. With the control box placed on the motor, screw in the bolts to the mounting points (Fig. 2-5)
4. Attach the Tie Wrap around the small bracket to hold it down and clip the excess length (Fig. 2-6 & 2-7)



Fig. 2-1



Fig. 2-2

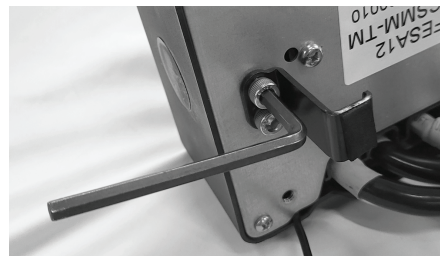

Fig. 2-3

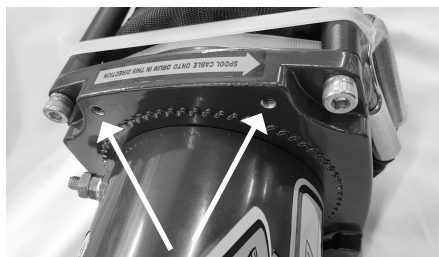

Fig. 2-4



Fig. 2-5



Fig. 2-6



Fig. 2-7

WIRING INSTRUCTIONS

Wiring the Control Box

1. Slip the boots onto pertinent cables and make electrical connection in accordance with the schematic on following page. Slide the boots onto all the electrical connections made (Fig. 2-12 through 2-14).
2. Run battery power cables carefully under hood of vehicle, avoiding interference with moving parts and abrasion points which could potentially cause electrical short.
3. Attach BLACK Cable to NEGATIVE Battery Terminal (-), followed by RED Cable to POSITIVE Battery Terminal (+) (Fig. 2-14). Refer to Winch Operation on page 8 of this manual for proper functioning; if drum rotates in the incorrect direction when "IN" button is pressed, green and yellow motor cables need to be switched.

CAUTION: Cover all exposed electrical connections with insulation boots to avoid electrical short. Battery cables should not be drawn taut; leave some slack for cable movement. Ensure all connections are routed properly and do not interfere with the vehicular components, as this could damage cable or cause electrical short. Long battery cable runs may have significant voltage drops that may cause the winch motor to not operate.

DO NOT CONNECT POWER CABLES TO BATTERY UNTIL FINAL STEP OF INSTALLATION

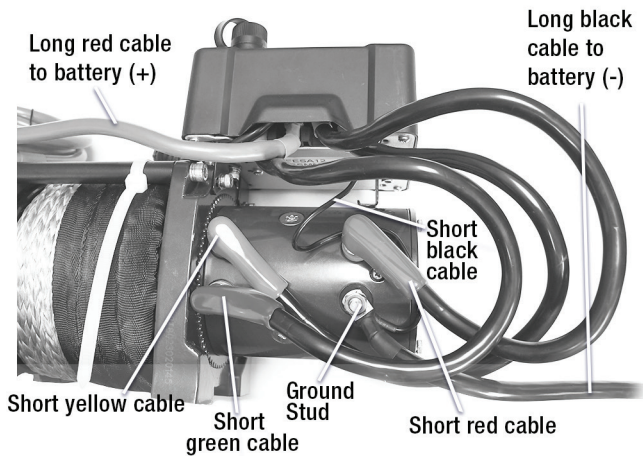

Fig. 2-12

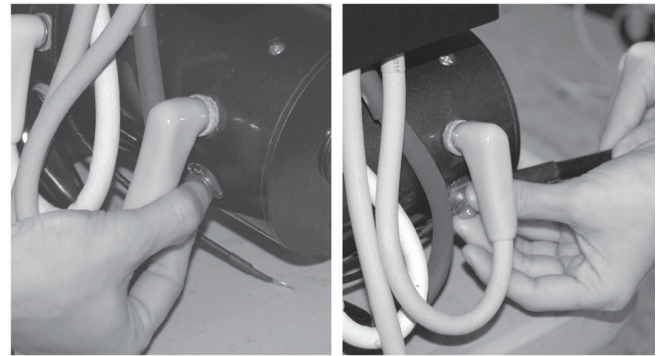

Fig. 2-13

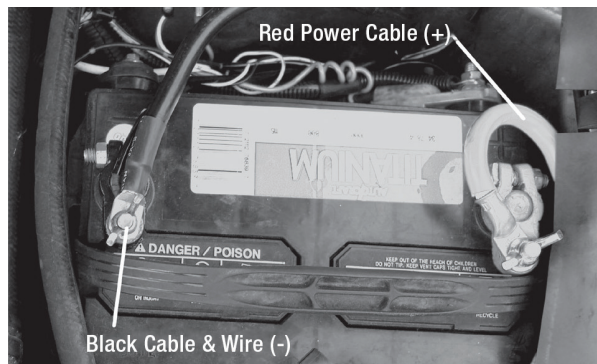
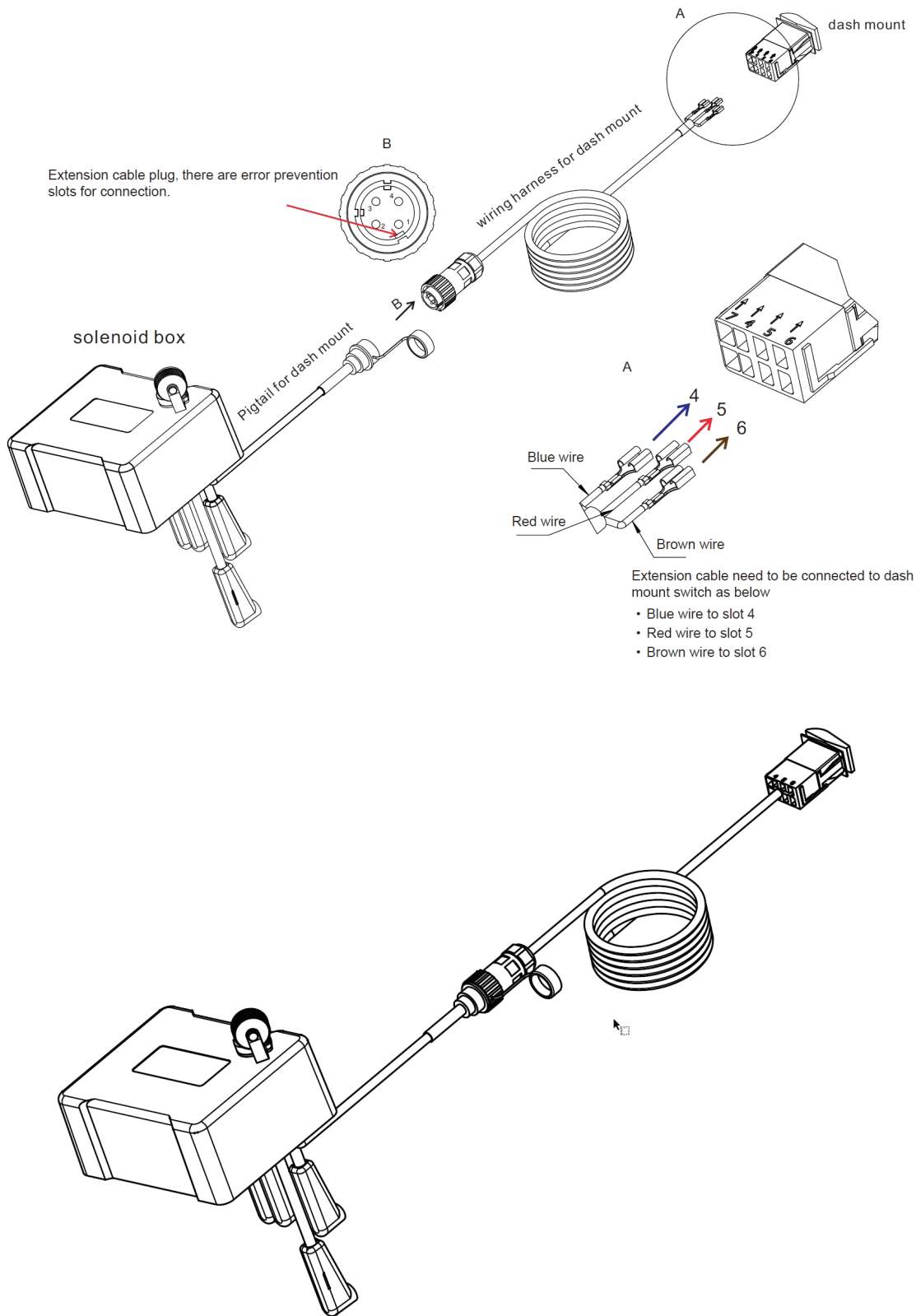

Fig. 2-14

Dash Mount Plug In and Connection to Control Box



WINCH OPERATION

Operational Instructions

1. Disengage the clutch by moving the Clutch Lever to Disengage Position (or Freespool mode) (Fig. 3-1)
2. Free Spool the cable and connect to the desired anchor point (self recovery) or vehicle being recovered
3. Fully Engage the clutch by moving the Clutch Lever to Engage Position (Fig. 3-1)
4. Lift the protective boot covering the hand control plug-in. Insert the hand control plug
5. Start winching IN (Fig. 3-2) to remove the slack on the cable, ensuring that the cable is winding onto the drum properly (with out any overlapping or gaps). Never disengage the clutch while the cable is under load.
6. When finished winching, let off the load by winching OUT (Fig. 3-2). With adequate slack created, unhook the cable and rewind the cable onto the drum.

NOTE: Mile Marker recommends a fully charged, 12V battery with a minimum of 650 cold-cranking amperes. Recommended: keep engine running during winch operation to continuously charge battery.

NOTE: All Mile Marker winches are equipped with a clutch lever that engages/disengages the clutch. When engaged, the clutch will couple the gear train and the winch drum to lock the winch. When disengaged, the clutch de-couples the gear train from the winch drum, enabling the drum to rotate independently or free spool.

CAUTION: Before using your new Mile Marker electric winch, rewind the entire steel cable/synthetic rope on the drum under a load of at least 500 lbs (227 kg) starting with at least 5 wraps of steel cable, or 10 wraps of synthetic rope on the initial layer. Failure to do so will result in the outer wraps pressing against the inner wraps, damaging the steel cable/synthetic rope. Always have at least 5 wraps of steel cable, or 10 wraps of synthetic rope on the winch drum BEFORE winching and make sure the clutch is fully engaged or fully disengaged to avoid any injuries or damages. Electric winches are for intermittent use only. Never run the winch for more than 1 minute at maximum rated load and wait until the motor cools down before resuming winch operations. To reduce the load on a winch motor, the use of a snatch block is recommended (see pages 9 and 10, Winching Tips & Techniques for snatch block usage). This winch model also features an automatic load holding brake, so never run the winch against the brake ("OUT" on the hand control) for more than 10 seconds. Failure to do so might result in damage to the brake and motor. Always stay clear of the loaded winch steel cable/synthetic rope.

ENGAGED



Fig. 3-1

DISENGAGED

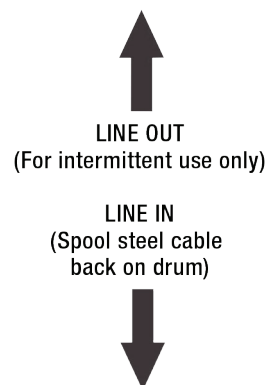

Fig. 3-2



WINCHING TIPS & TECHNIQUES

Winching Tips and Use of a Snatch Block

- Use tow hooks, recovery eyes or a clevis mount for attachment of a tow strap or winch steel cable/synthetic rope.
Warning: Do not use a ball and/or ball mount as an anchor point for tow strap or winch steel cable/synthetic rope. Severe personal injury or death could occur.
- Always heed all winch manufacturer's recommendations, cautions, and warnings.
- Attach return steel cable/synthetic rope to tow hook or recovery eye when using a snatch block. Always use a clevis to secure snatch block to strap, or severe damage could occur to persons and vehicle.
CAUTION: Do not attach return steel cable/synthetic rope to winch mount. This may overload winch mount and/or front receiver.

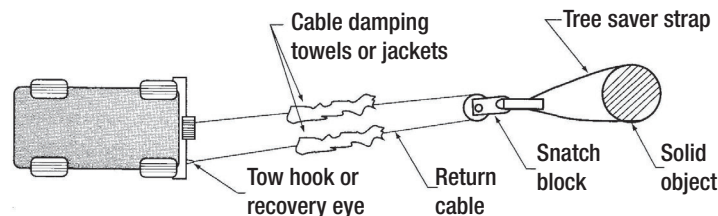

Rating

For maximum line pull rating, winch cable direction must not exceed:

1. 15° angle up or down from horizontal (see image to right)
2. 45° angle left or right from straight ahead (see image to right)

Caution: Exceeding the maximum line pull rating may overload winch, winch mount, and/or front mounted receiver.

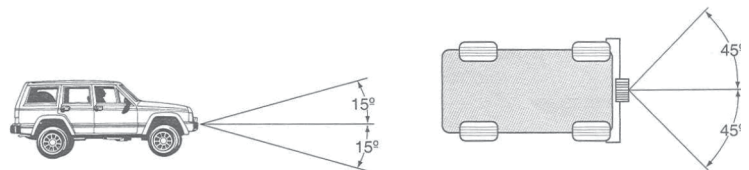

Safety Tips

- DO NOT DISENGAGE CLUTCH LEVER WHEN THERE IS A LOAD ON THE WINCH. Mile Marker electric winches utilize an automatic load holding brake, therefore no adjustment to clutch is needed to maintain load.
- Store the remote control cord in a safe place when not in use to prevent use by children or other unauthorized persons who could injure themselves or others or damage the controls
- Do not operate winch under the influence of drugs, alcohol, or medication
- Isolate winch before putting hands in or around the roller/hawse fairlead or drum
- DO NOT OVERLOAD YOUR WINCH. Do not maintain power to the winch if the drum stops. Overloads can damage the vehicle, winch or winch steel cable/synthetic rope and create unstable operating conditions.
- It is recommended to lay a dampener over the steel cable/synthetic rope about halfway along to the hook attachment. If a steel cable/synthetic rope failure should occur, the weight of the dampener will help prevent the broken steel cable/synthetic rope from whipping. Remember to move the dampener as winching proceeds, but halt winching when doing so. Partially raising the hood of the vehicle will also give a measure of protection to its occupants from broken steel cable/synthetic rope, consistent with sufficient forward visibility for the operator.

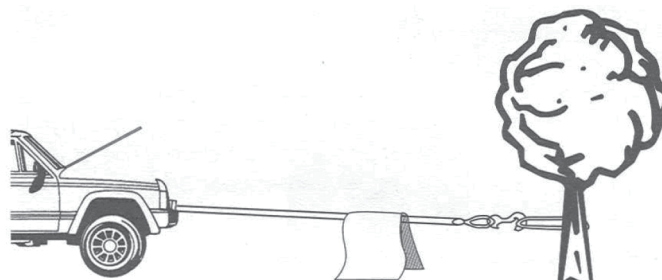

Self Recovery

1. Always attempt to get the synthetic rope as straight as possible to the direction of the vehicle. It is acceptable to start a pull at an angle if it is obvious that the vehicle will turn towards the hook anchoring point. Turning the steering wheel will assist the process. It is recommended that the driver is in the vehicle.
2. Make sure hand brake and foot brake are free and that the transmission is in neutral
3. When the driver's attempt to regain vehicle traction is successful, he or she should be careful not to overrun the cable and risk the possibility of it being trapped under the vehicle
4. DO NOT move your vehicle in reverse to assist the winch. The combination of the winch and vehicle pulling together could overload the cable and winch itself.
5. DO NOT connect synthetic rope or hook back to winch mount

Use of a Pulley Block or Snatch Block

Vehicle self recovery using the pulley block attached to the anchor point for direct pull. In this instance the vehicle becomes the "load" and the actual pulling power on the vehicle will be double at half winch steel cable/synthetic rope speed. Do not connect steel cable/synthetic rope or hook back to winch mount.

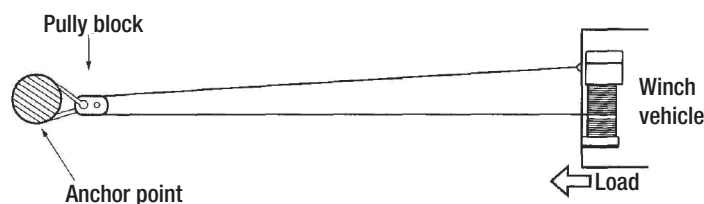

Direct pull on load using the winch vehicles as the anchor with pulley block attached to the load. The most important aid to successful winching is the pulley block, which can be used to increase the pulling power of the winch of for indirect pulls. Pulley blocks can be used in two modes. First mode is attached to the load and second is secured to an anchor point.

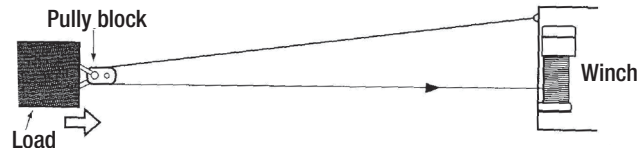

Indirect pull necessitated by obstructions or soft ground. Attach pulley block to load using a suitable anchor point.

NOTE: The angled direction taken by the load and subsequent angle of synthetic rope feed back on the winch drum (extreme example shown). There may be unavoidable circumstances requiring this mode, though in general it is not recommended unless applied in stages by moving the anchor point or vehicle to avoid the sharp angled rewind on the winch drum. The actual load pulling power and synthetic rope speed will depreciate with any increased angle between the synthetic ropes. The anchor point, when used must be secure, using a tree, another vehicle or any firm structure to which a pulley block can be used to your advantage.

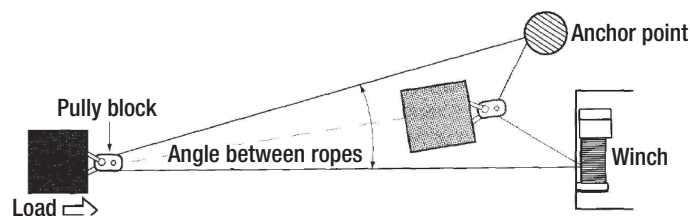

Use of a Nylon Sling and Shackle

The safe working load of the nylon sling is based on the use of both eye ends. Do not use the cable or hook to connect directly to the nylon sling. A shackle should always be used when attaching winch hooks to nylon slings. NOTE: The shackle must pass through both eyes of the sling.

WINCH MAINTENANCE

- All moving parts within the electric winch have been lubricated using high temperature lithium grease at the factory. No further internal lubrication is required for the life of the winch.
- Clean and examine entire synthetic rope for damage.
- Electrical connections may corrode over a period of time due to environmental changes. This may result in reduced performance of the winch or even possible electrical shorting. Hence, always clean the electrical connections before and after using the winch.
- After every use of the winch, inspect the synthetic rope for damages such as kinks, broken strands etc. When damaged, replace the synthetic rope immediately.

To secure the rope effectively on a Mile Marker winch drum, you should follow a precise procedure.

1. **Passing the Rope Through the Drum:** Start by passing the rope through the opening within the winch drum. This initial step ensures that the rope is properly threaded through the drum.
2. **Pulling X Amount of Rope:** Pull a specific length of rope through the drum, approximately 3/4 the length of the drum. The exact length, denoted as 'X,' will depend on your specific winch and the application. This step is crucial for having the right amount of rope on the drum.
3. **Locking the Rope:** To secure the rope in place, lay it over itself on the drum. This creates a locking mechanism that prevents the rope from slipping or unraveling during operation. Ensure that the rope is tightly wound over itself.
4. **Using Tape for Additional Security:** Consider using tape to further secure the rope on the drum. This can provide extra stability and prevent any unintended movement of the rope during winching operations.
5. **Maintaining a Minimum of 8 Wraps:** Before applying a heavy load, make sure that you have a minimum of 8 wraps of rope on the drum. This ensures that the rope is securely anchored and can handle the load without any slippage or issues.

By following these precise steps, you can ensure that the rope is securely spooled on the Mile Marker winch drum, providing reliable and safe winching operations.

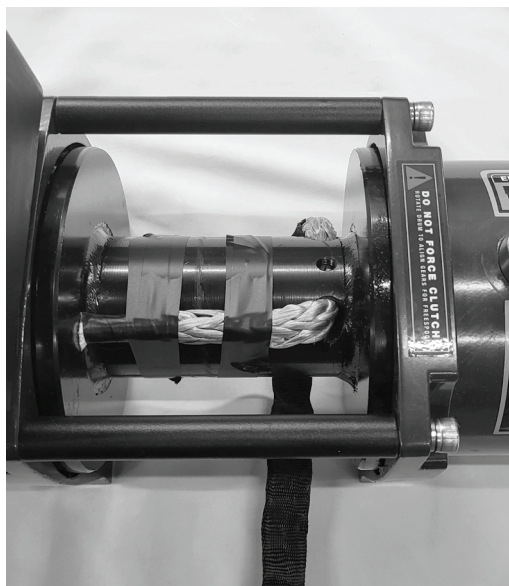

Security rope on drum

TROUBLESHOOTING

Symptom	Possible Cause	Suggested Remedy
Motor does not turn on	Safety switch is OFF	Turn safety switch ON
	Switch assembly not connected properly	Insert switch assembly firmly to the connector
	Loose battery cable	Tighten nuts on cable connectors
	- Connection - Solenoid malfunctioning	Tap solenoid to free contact, applying 12 volts to coil terminal directly. An audible clicking will occur when activating.
	Defective switch assembly	Replace switch assembly
	Defective motor	Check for voltage at armature port with switch pressed. If voltage is present, replace motor.
	Water has entered motor	Drain and dry. Run in short bursts without load until completely dry.
Motor runs too hot	Long period of operation	Let winch cool down periodically
Motor runs slowly or without normal power	Battery runs down	Recharge battery by running vehicle engine
	Insufficient current or voltage	Clean, tighten or replace the connector
Motor runs but cable drum does not turn	Clutch not engaged	Turn clutch gear to IN/ENGAGED position - if that does not work, ask a qualified technician to check and repair
Motor runs in one direction only	Defective or stuck solenoid	Tap solenoid to free contacts. Repair or replace solenoid.
	Defective switch assembly	Replace switch assembly

PARTS BREAKDOWN & ASSEMBLY

TM-10K

ITEM	QTY	PART#	DESCRIPTION	ITEM	QTY	PART#	DESCRIPTION
1	1	77-50141W-01	Dry Bearing	27	1	77-50141W-27	Thrust Washer
2	16	77-50141W-02	Screw M4 x 12	28	1	TM-10K-28	Brake/Shaft Assembly
3	16	77-50141W-03	Spring Washer M4	29	2	TM-10K-29	Tie Bar
4	1	77-50141W-04	End Bearing	30	1	77-50141W-30	Motor End
5	4	77-50141W-05	Spring Washer M8	31	1	TM-10K-31	Solenoid Assembly
6	4	77-50141W-06	Screw M8 x25	32	1	77-50141W-32	Solenoid Bracket 1
7	2	77-50141W-07	Gasket	33	1	77-50141W-33	Solenoid Bracket 2
8	1	77-50141W-08	Clutch Handle	34	1	TM-10K-34	Dashboard Switch Wire
9	1	77-50141W-09	Seal (3 pcs)	35	1	TM-10K-35	Dashboard Switch
10	1	77-50141W-10	Spring Washer	36	5	77-50141W-36	Washer M6
11	1	77-50141W-11	Gear Ring	37	5	77-50141W-37	Spring Washer M6
12	1	77-50141W-12	Retaining Screw	38	5	77-50141W-38	Screw M6 x 16
13	1	77-50141W-13	Gear Ring - input/intermediate	39	2	77-50141W-39	Washer M6
14	1	77-50141W-14	Gear Carrier Assembly - output	40	2	77-50141W-40	Spring Washer M6
15	1	77-50141W-15	Gear Carrier Assembly - intermediate	41	2	77-50141W-41	Screw M6 x 12
16	1	76-50251BW-16	Gear Carrier Assembly - input	42	1	76-50145-504	Negative Power Wire
17	1	76-50251BW-17	Gear - input sun	43	1	76-50140-39	Plastic Strap
18	1	77-50141W-18	Gear Bushing	44	2	77-50141W-44	Fairlead Nut
19	1	77-50141W-19	Gear Box Cover	45	2	77-50141W-45	Fairlead Bolt
20	2	77-50141W-20	Spacer	46	6	77-50141W-46	Washer M10
21	2	77-50141W-21	Ring	47	4	77-50141W-47	Spring Washer M10
22	2	77-50141W-22	Seal Ring	48	4	77-50141W-48	Screw M10 X 30
23	1	TM-10K-23	Drum Assembly	49	1	1951203-CB	Safety Hook
24	1	77-50141W-24	Screw	50	1	77-50141W-50	Switch Assembly
25	1	77-50141W-25	Cable Anchor	51	1	19-50042BTG	Hand Strap
26	1	77-50141W-26	Screw	52	1	19-52001-TM	** Hawse Fairlead
				53	1	19-52038-50	** Synthetic Rope

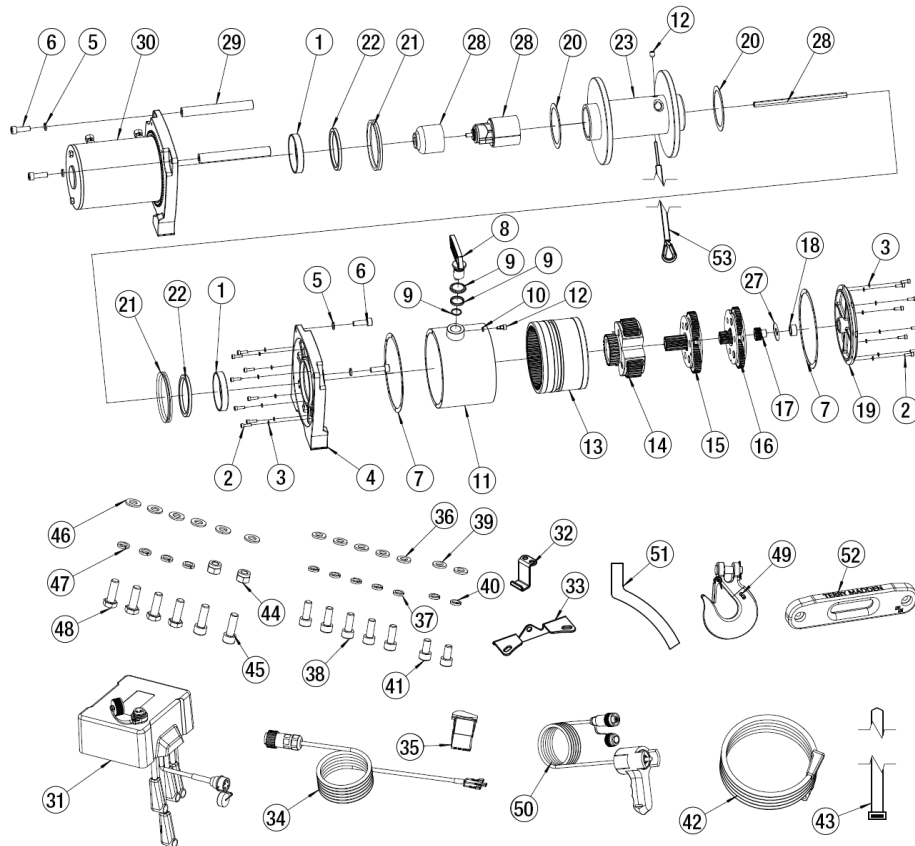

WARRANTY

Warranty registration must be submitted at MileMarker.com/warranty within 30 days of purchase by the end user. If you discover a hidden defect, Mile Marker Industries, Inc. will, as its option, repair or replace the product or necessary replacement parts at no charge to you, if you return it prepaid to Mile Marker Industries, Inc. at 2121 Blount Road Pompano Beach, FL 33069. If the product was purchased in the United States, the owner must contact our warranty department to get a Return Goods Authorization (RGA) number before returning the product. If the product was purchased outside the United States, the owner must return the product to the original place of purchase.

Mile Marker Industries, Inc. Electric Winch Limited Two Year Warranty

Mile Marker Industries offers a limited two year warranty to the original retail purchaser for each new Mile Marker electric winch, used as a recreational recovery winch only, against manufacturing defects in workmanship and materials on all mechanical components. Electrical components consisting of motors, solenoids, wiring, wire connectors and associated parts have a limited one year warranty. New cable assemblies are warranted against defects in workmanship and materials when received by the retail purchaser. There is no applicable warranty for cable assemblies after initial use. Excluded from this warranty are the finish of the winch and any condition Mile Marker determines to have been caused by misuse or abnormal use. Warranty registration must be submitted at milemarker.com/warranty within thirty days by the end user. Warranty submissions must reference winch serial number to be valid. Warranty will only be valid for the original purchaser of the winch and installed on the vehicle for which it was originally registered. The owner will be responsible for removing the winch and returning it to Mile Marker freight prepaid unless a determination is made that replacement parts can be sent out which will remedy the problem. Mile Marker will repair or replace any or all winch parts, which after inspection determines to be defective. If the product was purchased in the United States, the owner must contact our warranty department to get a Return Goods Authorization (RGA) number before returning the product. If the product was purchased outside the United States, the owner must return the product to the original place of purchase.

For full warranty and general warranty policies and procedures, please visit MileMarker.com/warranty.

 **WARNING:** This product contains chemicals known to the State of California to cause cancer and birth defects or other reproductive harm. For more information, go to www.P65Warnings.ca.gov.



Learn more



MILEMARKER.COM

INFO@MILEMARKER.COM

1-800-886-8647

2121 BLOUNT ROAD

POMPANO BEACH, FL 33069

