

 FOLDING MACHINES



SHEET METAL MACHINERY FOR LIFE

CIDAN
MACHINERY

SINCE 1907



Picture from early 1900s

CIDAN Machinery Sweden AB, better known under the former name Göteneds Mekaniska Verkstad AB in Sweden, has been manufacturing machines since 1907. During the 1940s, Göteneds began to design and manufacture high quality machines for sheet metal processing. This trend has continued throughout the years and has resulted in a number of patented solutions and designs, a development we are proud of and cherish. We continue to develop machines for the sheet metal fabricating industry and still offer our customers highly accurate, reliable and robust machines.

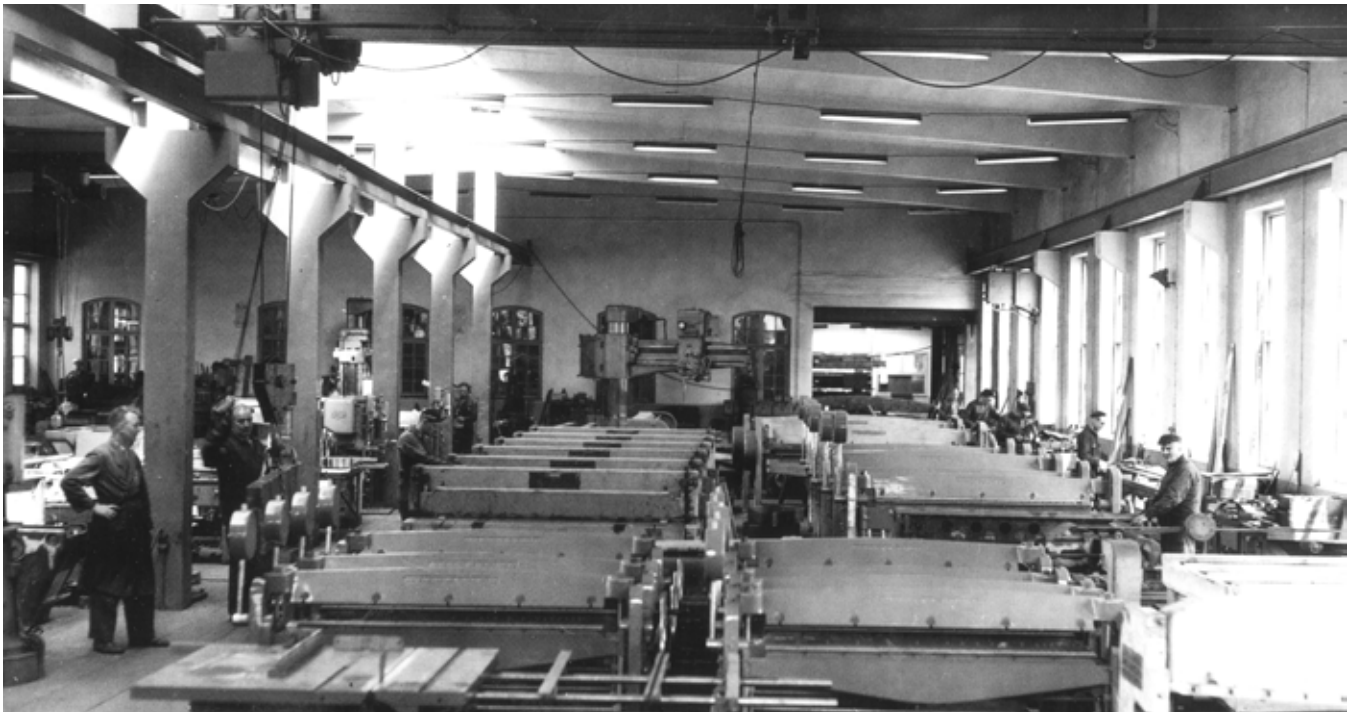

Picture from 1948

Despite CIDAN's worldwide reach and presence, all designs, concepts and machines are still being created in Götene, Sweden. While incorporating state of the art equipment and concepts the philosophy and core values remain the same as it did in 1907. Our machines are marketed under the brand names CIDAN and Göteneds. We have chosen to continue to sell machines under the name Göteneds in the Nordic countries, a name that since way back is strongly associated with quality and reliability. In the rest of the world our machines are sold under the brand name CIDAN.



A CIDAN folding machine offers a convenient, flexible and efficient way to bend sheet metal into various details. Below you will find some of the advantages the folding machine offers in comparison with other process methods.

ERGONOMICS

When using a folding machine the sheet is supported by the back gauge table and back gauge stops during the bending process. This will secure a safe working environment as the operator does not need to support the often heavy sheet during the bending process, which reduces the risk of work related injuries.

FAST SETUP

Our folding machines are equipped with a universal set of tools and flexible software to provide operators with the tools they need to eliminate long tool set-ups, and be the most efficient with their operating time. The ProLink X software even gives the ability for remote offline programming and machine to profile interfacing.

NO MARKS OR SCRATCHES

The bending process on a folder will not leave any marks even on sensitive material such as pre-painted material and stainless steel.

QUICK TOOL CHANGES

With the Combi beam you will be able to change between straight and box tools in a few seconds. The change is 100% controlled by the machine's software and will take place without any hands involved – all you have to do is to press the foot pedal.

LOW TOOLING COST

The bending process on a folder eliminates wearing of the tooling, therefore the tools purchased with the machine should last the life of the machine.

EASY AND LOGICAL PROGRAMMING

Through graphic programming and the process of drawing out your profile in the software, the machine will automatically calculate the parameters needed to successfully bend the part. Paired with our Automatic Folding Sequence parts are now programmed and produced more efficiently than before.



PROFITABLE PRODUCTION AND GOOD WORKING ENVIRONMENT

PRODUCT OVERVIEW



PIVOTAL p. 6



K15 p. 7



K25 p. 8



FORMA p. 9



PROLINO p. 10



PRO p. 11

Folding length m (")

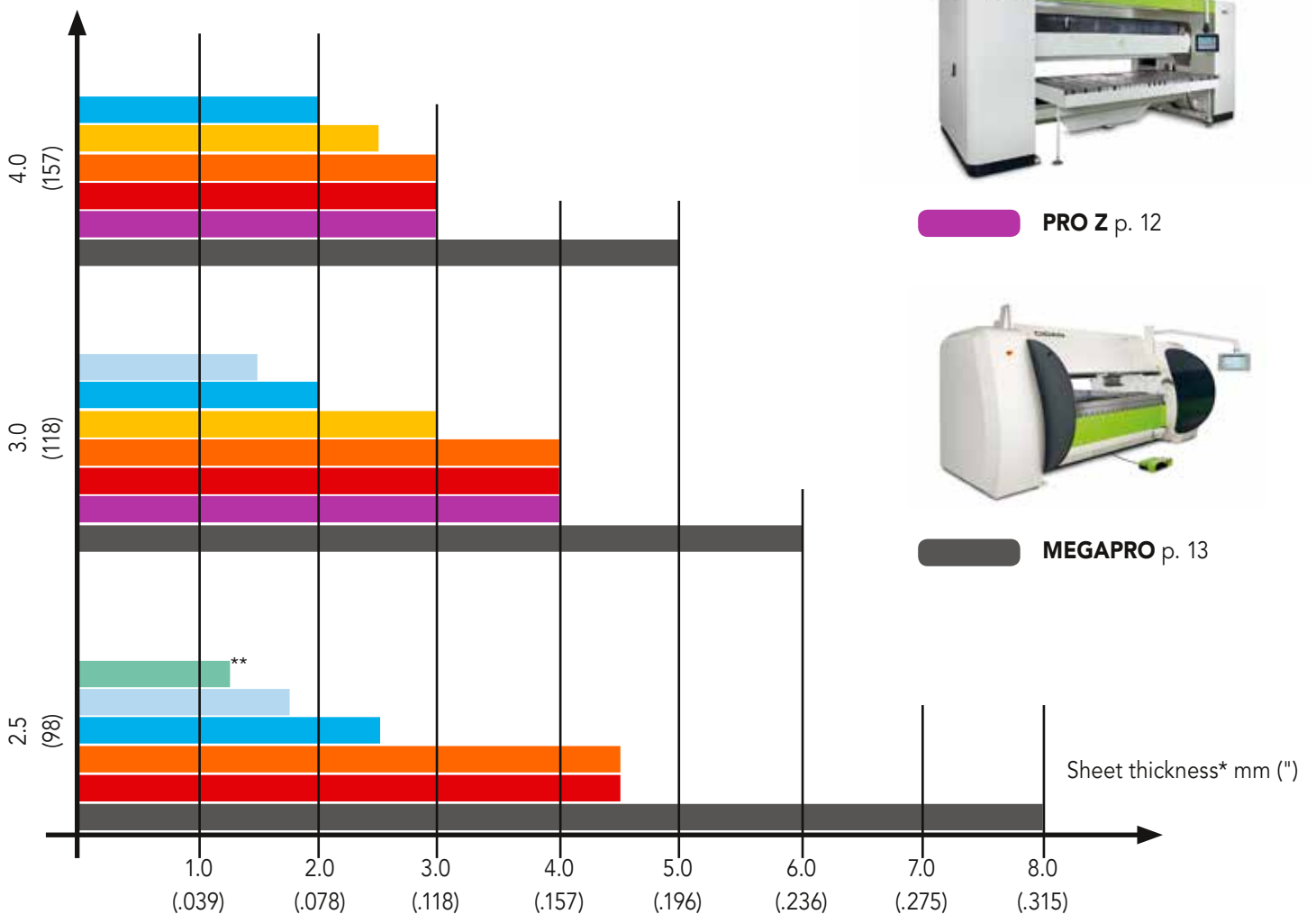

PRO Z p. 12



MEGAPRO p. 13

* At tensile strength 400 N/mm², ** PIVOTAL folding length 2.3 m (90)

OUR UNIQUE SOLUTIONS

COMBI BEAM TOOL CHANGER

The optional Combi beam offers a flexibility like no other tooling system. With a simple rotation of the upper beam you can switch between the straight rail and divided box tooling in a matter of seconds. This gives you the ability to form a larger variety of parts with little or no tool changing.

Advantages with Combi beam:

- Quick tool changes
- Large space around the tools
- Increased flexibility
- Same opening height regardless of tool selection



MULTIFOLD - MAXIMUM FLEXIBILITY

Divided tooling for maximum flexibility in every situation! With the optional Multifold execution the lower beam and folding beam tools are segmented. This caters to parts that have flanges facing downward into the machine. This allows the operator to bend weld tabs and parts with interrupted bend lines. Almost all of our models can be equipped with Multifold and an addition of height adjustable back gauge increases the benefit of Multifold, see below. Multifold requires high divided tools in the upper beam.

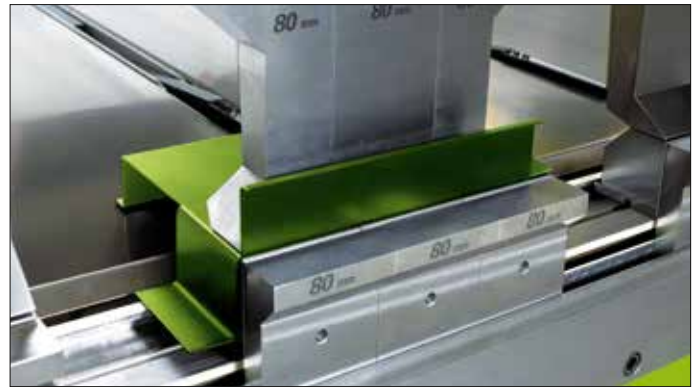

HEIGHT ADJUSTABLE BACK GAUGE

Our robust back gauge systems AGS and SBG can as option be supplied with height adjustment. This is perfect for gauging reverse z-flanges on the back gauge. Height adjustable back gauge requires multifold execution, see above.



Examples of folded parts

PIVOTAL 360°



CIDAN **PIVOTAL 360°** can produce details like no other machine. Now you can do closed profiles and narrower details with minimal number of joints. Just slide the folded part from the beam and merge only one seam. With traditional manufacturing methods, you must fold two profiles that needs to be welded together in two joints. Now closed details can be made of only one part and with one seam to achieve cost savings.

PIVOTAL is made in a sturdy all-welded steel construction with cast iron side frames for stability. Control system ProLink X, frequency control and 2.2 kW motor gives you a strong and easy-to-use machine, built for demanding conditions. PIVOTAL is equipped with the popular AGS back gauge for the best accuracy.

- Crowning adjustment as standard always gives perfect folding result
- Make closed profiles with only one seam
- Large freedom to design your profiles
- ProLink X control system with plenty of features
- 10 back gauge stops for both small and large parts across the bending length of the machine
- Divided lower beam rail as option

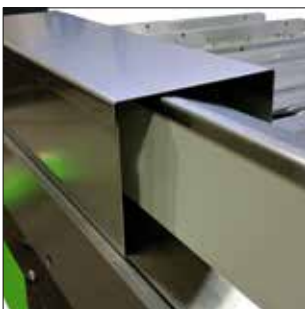

Fold the profile around the beam.



It is easy to produce a closed profile with only one seam.



Open the beam when the folding sequence is finished.

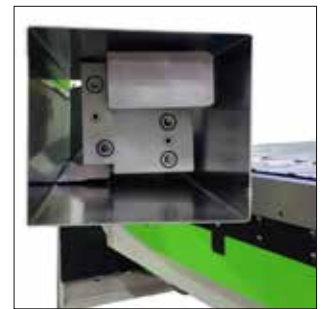

Slide the finished profile off the beam.

STANDARD RAILS

Straight rail 30°, folding beam rail 15 mm (.591"), folding beam rail 30 mm (1.18")

Model	Folding length	Folding capacity			Opening height	Outer dimensions****	Weight	Motor	
		Steel* mm (ga)	Stainless steel** mm (ga)	Aluminium*** mm (")				Clamping beam mm (")	kg (lbs)
PIVOTAL 360°	2300 (90)	1.25 (18)	0.80 (24)	1.90 (0.074)	135 (5.3)	3700 x 1700 x 2200 (146x67x87)	3600 (7.937)	1.5 (2)	2.2 (3)

Tensile strength *at 400 N/mm²-58000 lbf/in² (psi) - **at 600 N/mm²-87000 lbf/in² (psi) - ***at 200 N/mm²-29000 lbf/in² (psi) - ****With motorized back gauge AGS base unit



With CIDAN **K15** you can quickly and easily create the parts and profiles you need for your work. Just program the control system and then run. The compact folding beam moves quickly and you consistently stand near the machine without having to take a step back. First row stop fingers in spring steel provides unbeatable small gauging measure and eliminate risks for marks in the material, which is common by machines that have cut-outs in the rail. Folding rails with quick change tooling system ensures fast changes and you get three widths to choose from as standard. When you buy a CIDAN K15, you get a folding machine that is easy to program, fast to run and, of course, gives a really good folding result. Job satisfaction, pure and simple!

- Crowning adjustment as standard always gives perfect folding result
- Two folding beam rails with width 7/10 mm (0.28"/0.39") and 20 mm (0.79") as standard
- Fast, reliable and user-friendly
- Choose between two control systems, EasyLink or ProLink X, both with plenty of features
- Multiple back gauge stops for both small and large parts across the bending length of the machine



Generous space around the tools for increased flexibility.



Quick change of tooling (bayonet style) and adjustable crowning.



Compact folding beam, only 280 mm (11"), grants easy and ergonomic work at the machine.

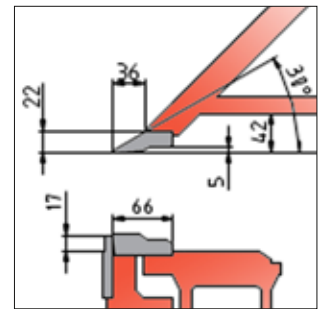

K15 with plenty of space behind the straight rail.

STANDARD RAILS

Straight rail 30°, double sided folding beam rail 7/10 mm (.275"/.394"), folding beam rail 20 mm (.787")

Model	Folding length	Folding capacity			Opening height	Outer dimensions****	Weight	Motor	
		Steel* mm (ga)	Stainless steel** mm (ga)	Aluminium*** mm (")				Clamping beam mm (")	Length x depth x height mm (")
K15-25	2550 (100)	1.75 (15)	1.10 (19)	2.60 (0.102)	115 (4.5)	3530 x 1595 x 1590 (139x63x63)	2055 (4.521)	0.75 (1)	1.1 (1.5)
K15-30	3100 (122)	1.50 (16)	0.90 (20)	2.20 (0.090)	115 (4.5)	4030 x 1595 x 1590 (159x63x63)	2370 (5.241)	0.75 (1)	1.1 (1.5)

Tensile strength *at 400 N/mm²-58000 lbf/in² (psi) – **at 600 N/mm²-87000 lbf/in² (psi) – ***at 200 N/mm²-29000 lbf/in² (psi) – ****With motorized back gauge EGS

K25



CIDAN **K25** is a versatile and strong folding machine. The cast iron side frames, twin drive of both folding beam and upper beam, and the eccentric clamping, all give you a trouble-free operation at a low maintenance cost. The optional Combi beam provides the ability to change tools in seconds. The user-friendly control systems EasyLink or ProLink X allows easy programming and use regardless if the operator is experienced or not. Equip your K25 with ProLink X and you will get a much faster machine thanks to the more powerful motor and higher gearing. With the CIDAN K25, you will get a reliable and efficient work horse, day after day, year after year.

- Sturdy construction
- Built for demanding conditions, 100% duty cycle
- Same opening height regardless of tooling (Combi beam)

- Versatile and flexible
- Variety of options available for added flexibility
- Generous space around the tools for increased flexibility



Generous space around the tools for increased flexibility.



Quick change tooling (bayonet style) and adjustable crowning.



Compact folding beam grants easy and ergonomic work at the machine.

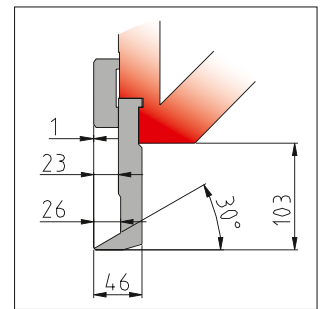

High divided tool 103 mm (4.0") together with combi beam.

STANDARD RAILS Straight rail 30°, double sided folding beam rail 7/10 mm (.275"/.394"), folding beam rail 20 mm (.787")
K25-40, double sided folding beam rail 10/15 mm (.394"/.591"), folding beam rail 30 mm (1.18")

Model	Folding length	Folding capacity			Opening height	Outer dimensions****	Weight	Motor	
		mm (")	Steel* mm (ga)	Stainless steel** mm (ga)				Aluminium*** mm (")	Clamping beam mm (")
K25-25	2550 (100)	2.50 (13)	1.60 (16)	3.70 (0.146)	135 (5.3)	3680 x 1694 x 1800 (145x67x71)	3500 (7.700)	1.5 (2)	1.5 (2)*****
K25-30	3100 (122)	2.00 (14)	1.20 (18)	3.00 (0.118)	135 (5.3)	4190 x 1694 x 1800 (165x67x71)	3685 (8.100)	1.5 (2)	1.5 (2)*****
K25-40	4050 (159)	2.00 (14)	1.20 (18)	3.00 (0.118)	135 (5.3)	5180 x 1694 x 1800 (204x67x71)	4400 (9.680)	1.5 (2)	2.2 (3)

Tensile strength *at 400 N/mm²-58000 lbf/in² (psi) - **at 600 N/mm²-87000 lbf/in² (psi) - ***at 200 N/mm²-29000 lbf/in² (psi) - ****With Combi clamping beam and motorized back gauge AGS Base unit - ***** 2.2 kW (3) with ProLink X



The CIDAN **FORMA** reflects decades of experience in both technology and design. FORMA from CIDAN is a "Cross-over" that handles both the requirements from small series production to proper subcontracting. Speedy production (low cost), Sweet to the operator (easy ergonomics), Strong construction (machines for life). Simplicity in programming and quick tool changing reduces setup times to a minimum. Dual drive of the upper beam together with a new locking principle, **CLS**, that holds the clamping beam, gives a high clamping pressure and a great folding result. Both rails and tools are easily changed and crowning is easily adjusted. FORMA is equipped with Combi beam as standard and as option it can be provided with Multifold.

- Sturdy construction
- Dual motors for the folding beam
- Same opening height regardless of tooling (Combi beam)
- Dual motors for the upper beam
- Variety of options available for added flexibility
- Generous space around the tools for increased flexibility



Automatic material sheet thickness adjustment, controlled by ProLink X

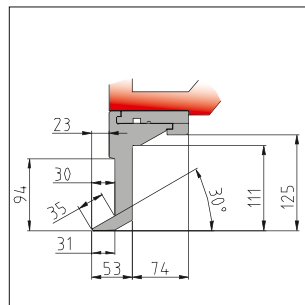

High divided tool 125 mm (4.9"), also available in 150 (5.9") and 200 mm (7.8") or C-shaped in 125 or 150 mm.



Corner tools are included in high divided tools. Collapsible corner tools are available as option.

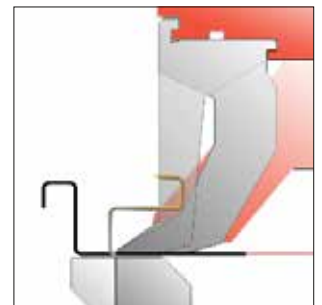

With C-shaped tools you can fold deeper profiles than with standard tools or straight rail.

STANDARD RAILS

Straight rail 30°, folding beam rail 15 mm (.591"), folding beam rail 30 mm (1.18")

Model	Folding length	Folding capacity			Opening height	Outer dimensions****	Weight	Motor	
		Steel* mm (ga)	Stainless steel** mm (ga)	Aluminium*** mm (")				Clamping beam kW (hp)	Folding beam kW (hp)
FORMA 30	3100 (122)	3.00 (11)	1.90 (14)	4.50 (0.177)	195 (7.7)	4465 x 2370 x 1980 (176x93x78)	4500 (9.920)	2 x 1.1(2 x 1.5)	2 x 1.5 (2 x 2)
FORMA 40	4100 (161)	2.50 (12)	1.60 (16)	3.70 (0.146)	195 (7.7)	5465 x 2370 x 1980 (215x93x78)	5400 (11.905)	2 x 1.1(2 x 1.5)	2 x 1.5 (2 x 2)

Tensile strength *at 400 N/mm²–58000 lbf/in² (psi) – **at 600 N/mm²–87000 lbf/in² (psi) – ***at 200 N/mm²–29000 lbf/in² (psi) – ****With motorized back gauge AGS Base unit

PROLINO

CIDAN combines over 20 years of production experience of heavy gauging machines with the **PROLINO**, a production that started with the well-known K50, earning the reputation to deliver a reliable and proven 4 mm (9 ga) x 3.1 meters (122") machine to the heavier sheet metal industry. The advantages of a PROLINO is the ability to customize your CIDAN folder to the exact specifications needed for your application. This machine can fold complex profiles and large panels with high precision, increased flexibility and productivity, therefore it is the perfect choice for industrial manufacturing.

- The combination of an eccentric pull down that drives the upper beam with 50 tons (55US) clamping pressure and dual drive for the folding beam makes the machine perfect for industrial manufacturing.
- With the crowning system it is possible to make exact bends with high precision and a precise folding radius.
- Optional Combi beam with high divided tooling and straight rail.
- The PROLINO can be prepared for high divided tools from 152 mm (5.9") up to 254 mm (10") height. Change of tool height does not require any machine change.

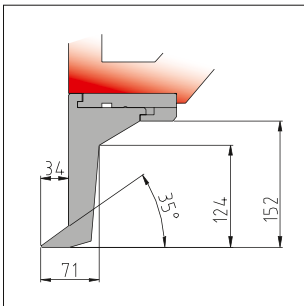

High divided tool 152 mm (5.9"), also available in 254 mm (10") or C-shaped in 152 mm (5,9").



AGS back gauge table for PROLINO Standard and PROLINO Combi beam machines.

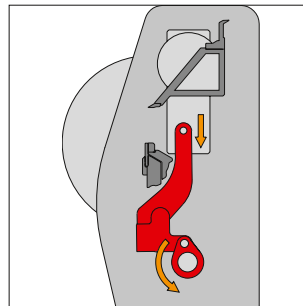

Eccentric drive gives optimal opening and closing speed, combined with high clamping pressure.

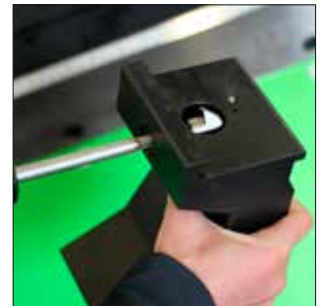

Divided tools with quick change for combi beam.

STANDARD RAILS

Straight rail 35°, folding beam rail 15 mm (.591"), folding beam rail 35 mm (1.38")

Model	Folding length	Folding capacity			Opening height	Outer dimensions****	Weight	Motor	
		mm (")	Steel* mm (ga)	Stainless steel** mm (ga)				Aluminium *** mm (")	Clamping beam mm (")
PROLINO 30	3100 (122)	4.00 (9)	2.50 (12)	6.00 (0.236)	200 (7.88)	4400 x 2535 x 2100 (173x100x83)	7800 (17.160)	4.0 (5.5)	5.5 (7.5)
PROLINO 40	4100 (161)	3.00 (11)	1.90 (14)	4.50 (0.177)	200 (7.88)	5400 x 2535 x 2100 (213x100x83)	9670 (21.274)	4.0 (5.5)	5.5 (7.5)

Tensile strength *at 400 N/mm²-58000 lbf/in² (psi) – **at 600 N/mm²-87000 lbf/in² (psi) – ***at 200 N/mm²-29000 lbf/in² (psi) – ****With Combi clamping beam and motorized back gauge AGS Base unit



The **PRO** is our most versatile machine with many features as standard. With the integrated back gauge it is possible to produce complex parts from the folding side. Heavier material and larger parts can be handled from the gauging side of the machine to improve work ergonomics and increase the quality. It is possible to replace two operators with one and still produce parts up to four times faster and with better accuracy compared to a press brake.

- Dual drive of clamping beam gives incredible speed and accuracy. The servo drive also increases hemming capacity to 50 tons (55US).
- Combi beam and Multifold with high divided tools and straight rail in combination with segmented tools in the lower beam and folding beam can facilitate extremely complicated folding work.
- Automatic folding beam crowning and automatic sheet thickness adjustment for precise folding.
- With high speed and extreme accuracy of the back gauge, exact measuring is ensured and with servo driven folding beam you will get the right folding angle every time.
- Height adjustable back gauge table available.

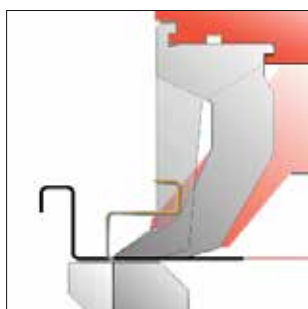

With C-shaped tools you can fold deeper profiles than with standard tools or straight rail.



Laser scanner on the folding side, recommended when working from gauging side.



SBG height adjustable back gauge table for PRO.



Both AGS and SBG back gauge tables are available in L-, J- or U-shape.

STANDARD RAILS

Straight rail 35°, divided folding beam rail 15 mm (.591"), divided folding beam rail 35 mm (1.38")

Model	Folding length	Folding capacity			Opening height	Outer dimensions****	Weight	Motor	
		Steel* mm (ga)	Stainless steel** mm (ga)	Aluminium*** mm (")				Clamping beam mm (")	Clamping beam kW (hp)
PRO 30	3100 (122)	4.00 (9)	2.50 (12)	6.00 (0.236)	200 (7.88)	4400 x 2535 x 2100 (173x100x83)	8130 (17.886)	4.0 (5.5)	5.5 (7.5)
PRO 40	4100 (161)	3.00 (11)	1.90 (14)	4.50 (0.177)	200 (7.88)	5400 x 2535 x 2100 (213x100x83)	10500 (23.100)	4.0 (5.5)	5.5 (7.5)

Tensile strength *at 400 N/mm²–58000 lbf/in² (psi) – **at 600 N/mm²–87000 lbf/in² (psi) – ***at 200 N/mm²–29000 lbf/in² (psi) – ****With motorized back gauge SBG-15

PRO Z



CIDAN's **PRO Z** is our new robust and highly rated up- and down folding machine, mainly targeted for industrial applications. The PRO Z model folds both upward and downwards to eliminate the need for an operator to flip the material. This provides excellent opportunities for time-efficient folding of complex details with one operator. Divided tools in both folding- and upper beam provides maximum flexibility with automatic tool locking. The machine's powerful motors contributes to a strong machine that works at high speed and precision.

- Folds upwards and downwards, no need to flip the material.
- 150 mm movement of folding beam, to move outside of material on folding side.
- Tooling in two different shapes and three different heights; one shape suitable for folding side operation
- Standard with Combi upper beam and Multifold, CNC controlled sheet thickness and folding center adjustment.
- The folding beam can be used as front gauge up to 150 mm.
- The PRO Z can be equipped with our Optimal Eccentric Drive **OED**^{PAT PENDING} for maximum clamping power regardless of tool height and sheet thickness.



Smart storage of tools for easy access.



Folding beam in lower position before clamping.



Folding beam in upper position before clamping.



ProLink X updated control system for PRO Z.

STANDARD RAILS

Straight rail 30°

Model	Folding length	Folding capacity			Opening height***	Outer dimensions*****	Weight	Motor	
		Steel* mm (ga)	Stainless steel** mm (ga)	Aluminium*** mm (")				Clamping beam mm (")	Length x depth x height x height mm (")
PRO Z 30	3200 (126)	4.0 (9)	2.50 (12)	6.00 (0.236)	254 (10)	4700 x 3590 x 2250 (185x141x89)	11850 (26.124)	2 x 3.8 (2 x 5.1)	2 x 9.5 (2 x 12.9)
PRO Z 40	4100 (161)	3.0 (11)	1.90 (14)	4.50 (0.177)	254 (10)	5700 x 3590 x 2250 (224x141x89)	13980 (30.820)	2 x 3.8 (2 x 5.1)	2 x 9.5 (2 x 12.9)

Tensile strength *at 400 N/mm²–58000 lbf/in² (psi) – **at 600 N/mm²–87000 lbf/in² (psi) – ***at 200 N/mm²–29000 lbf/in² (psi) – ****equipped with OED, for all tool heights – *****With motorized back gauge AGS Base unit



CIDAN folding machine model **MEGAPRO** is built in a sturdy and solid construction, which is important to be able to fold perfect details in 6 mm (1/4") steel or 4 mm (9ga.) stainless steel (applies on 3100 mm (122") folding length). The sturdy beams withstand the powerful folding forces by means of a very strong construction. CIDAN model MEGAPRO has many advanced CNC functions like adjustment of sheet thickness, folding center and crowning. MEGAPRO also has an automatic tool locking system in the upper beam as a standard feature.

- Dual servo driven motors for both clamping and folding beams gives incredibly fast speed and accuracy. High clamping pressure of 60 tons (66US) for accurate forming.
- CNC adjustment of folding center, sheet thickness and crowning.
- The clamping beam opens as the folding beam returns so that they are positioned for the next step simultaneously.

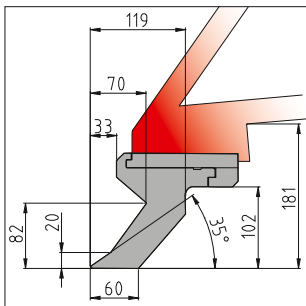

High divided tool 102 mm (4.01") also available in 152 mm (5.9").



Here a J-shaped back gauge, allowing one operator to handle large details. Height adjustment as option.



Power enough to fold up to 6 mm (0.236") mild steel.



CNC adjustment of folding center, sheet thickness and crowning.

STANDARD RAILS

Divided straight rail 35°, divided folding beam rail 20 mm (.787"), divided folding beam rail 40 mm (1.57")

Model	Folding length	Folding capacity			Opening height	Outer dimensions****	Weight	Motor	
		Steel* mm (")	Stainless steel** mm (")	Aluminium*** mm (")				Clamping beam mm (")	Length x depth x height mm (")
MEGAPRO 30	3100 (122)	6.0 (0.236)	3.80 (.149)	9.00 (0.354)	350 (13)	4700 x 3590 x 2250 (185x141x89)	11850 (26.124)	2 x 5.5 (2 x 7.5)	2 x 4.0 (2 x 5.5)
MEGAPRO 40	4100 (161)	5.0 (.196)	3.20 (.126)	7.50 (0.295)	350 (13)	5700 x 3590 x 2250 (224x141x89)	13980 (30.820)	2 x 5.5 (2 x 7.5)	2 x 4.0 (2 x 5.5)

Tensile strength *at 400 N/mm²–58000 lbf/in² (psi) – **at 600 N/mm²–87000 lbf/in² (psi) – ***at 200 N/mm²–29000 lbf/in² (psi) – ****With motorized back gauge SBG-15

AGS ACCURATE GAUGING SYSTEM



AGS^{PATENTED}

With our customers seeking more customized and flexible back gauges our latest system is our most innovative and flexible so far. With the AGS back gauge you can design your back gauge exactly to your needs. The base unit spans over the length of the machine and has a depth of 1550/1050/1550 mm (61/41.3/61"). Then you can install additional modules to the right or left up to a total depth of 4300 mm (169") and add in the middle section as well. You choose if you want your back gauge straight or shaped as a J, L or U. Should your needs change, you can with reasonable effort expand your back gauge by adding modules afterwards. It is even possible to add height adjustment afterwards. AGS back gauge is equipped with ball screw, linear guides and servo motor for highest precision and repeatability. The back gauge speed enables the productivity to increase and at the same time, decreases the costs of your forming operation. Front stop units are made of spring steel as standard, solid front stop units are optional (not for K25). The stop units can be dropped down automatically in every program row, which prevents any collision with the stop units when the sheet needs to be rotated. AGS with height adjustment is available for K25 Combi multifold and FORMA.



The back gauge system is driven by a servo motor with ball screw and linear guides which guarantees high precision and accuracy. Each back gauge position can be reached within 2 seconds.



Gauging rails can easily be moved sideways to pre-drilled holes for maximum adaptation, (not for AGS FH FR). The back gauge pans with ball transfers always fit due to the clever back gauge pan system.

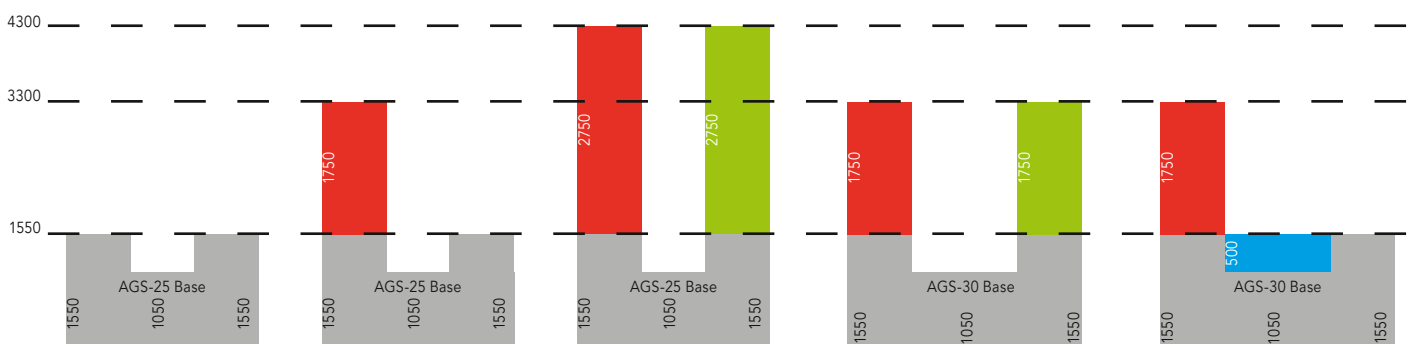

Examples of different back gauge configurations

AGS ACCURATE GAUGING SYSTEM

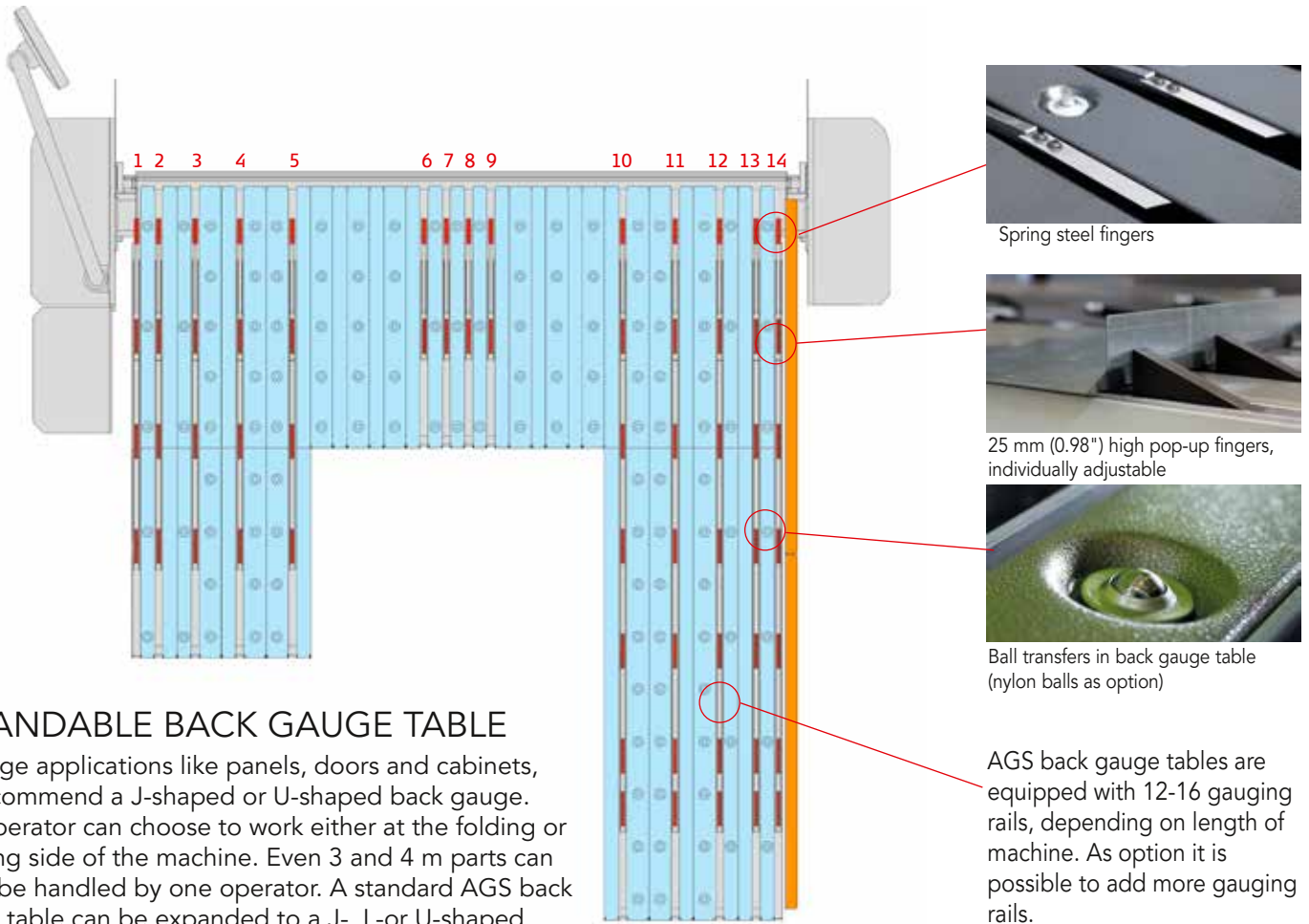

EXPANDABLE BACK GAUGE TABLE

For large applications like panels, doors and cabinets, we recommend a J-shaped or U-shaped back gauge. The operator can choose to work either at the folding or gauging side of the machine. Even 3 and 4 m parts can easily be handled by one operator. A standard AGS back gauge table can be expanded to a J-, L- or U-shaped back gauge table afterwards. See below for examples of different configurations.

AGS back gauge tables are equipped with 12-16 gauging rails, depending on length of machine. As an option it is possible to add more gauging rails.



Back gauge panels can be moved backwards when folded details require free space behind the lower beam tool.



Our back gauge system can be supplied with height adjustment. This is perfect for gauging reverse z-flanges on the back gauge. Height adjustable back gauge requires multifold execution (not for FORMA), and is controlled by ProLink X.

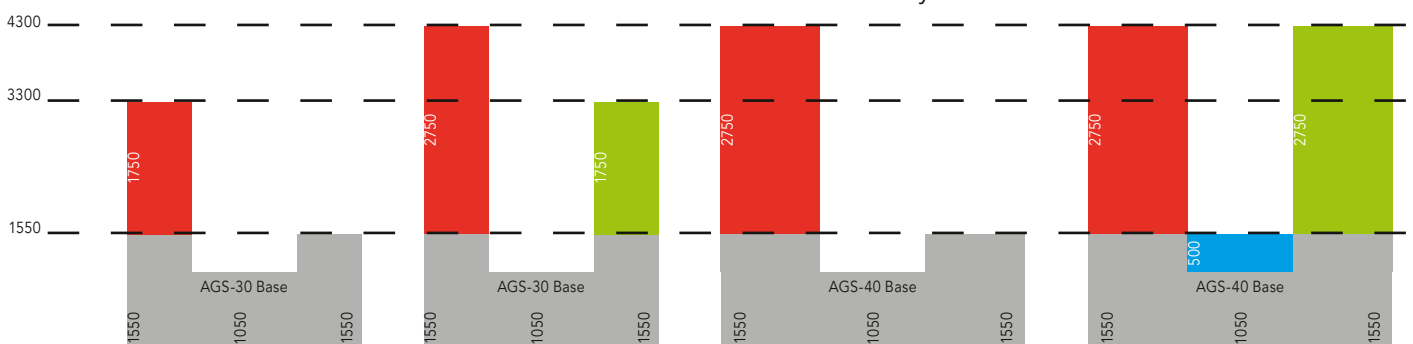

Examples of different back gauge configurations

EGS ENTRY GAUGING SYSTEM



Spring steel fingers

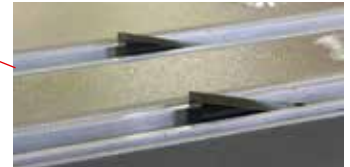

Pop-up fingers

EGS

The new EGS back gauge is a cost effective back gauge without the customization capabilities of the AGS system. Designed specifically for the K15 and K25, the EGS-25 is equipped with 10x2 stop units, EGS-30 with 12x2 stops units and EGS-40 has 14x2 stop units. First row stop units are made of spring steel as standard. The back gauge has one servo motor and belt drives on both sides and it takes less than two seconds to get an exact position between 2 and 1020 mm (.080"–40.2"). All the stop units can drop down automatically to avoid collision when the material needs to be rotated on the table. Available for all models of K15 and K25 only (ball transfers are available as option).

CONTROL SYSTEM



EASYLINK

EasyLink is a complete and user-friendly control system, fast and easy to program. **EasyLink** has the possibility to store 1000 profiles each with 99 steps. In every program step, the angle, gauge dimension, opening height, clamping pressure and hem pressure can be programmed.

Some of the possibilities available with **EasyLink** are copying programs, incremental dimensioning, and radius folding. From the touch screen the operator gets clear messages about the programming and operation. The Combi beam can be fully integrated into this control. The touch screen panel is mounted on a rotating bracket, so that the operator easily can adjust the screen to the situation.



PROLINK X

This latest version of ProLink takes programming to the next level keeping the user friendliness the same while adding a variety of new functions. This includes *Batch function*, which allows you to split the folding sequences into groups to save tool changing time. *Time estimation* is also a new feature where the control system calculates the time to produce one profile or a complete batch of profiles. Another feature is *Import of dxf files*; import your drawings directly into ProLink X via USB. New is also the possibility to plug in a USB *Barcode reader*. Attach barcodes to your sheets and scan, the control systems then knows how to fold the sheet. We also included *Remote access via TeamViewer*, possible problems can be investigated and solved remotely, quickly and easily. *Automatic Folding Sequence (AFS)*, with collision detection and calculation of an optimal folding sequence. The **ProLink X** can produce perfect parts efficiently and safely, even for an unskilled operator.



The control system with its simple functions is very easy to understand and learn. Interactive graphic pictures are shown to the operator with instructions like rotate or flip the part, a condition to correctly being able to produce complicated details. In the control memory you can store a large amount of programs and you can also store programs on a USB stick as well. Every program can be saved with a graphical icon, with name and information.

The **ProLink X** calculates cut size and automatically creates a program. The finished part is shown with its actual folding sequence. The touch screen is mounted on a pendant arm that can be rotated for optimal viewing. It is also possible to turn the screen to the gauging side of the machine when folding large details. With the offline-software option, programming can be completed in the office away from the machine.

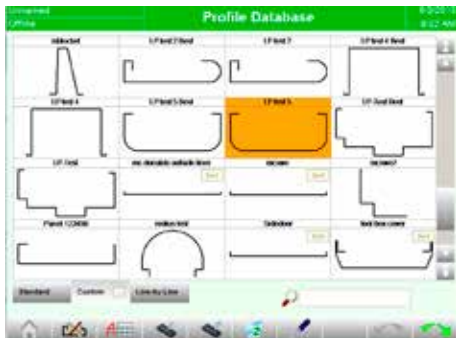

Find a detail similar to what you need in the library and use the drawing to create your own new detail.

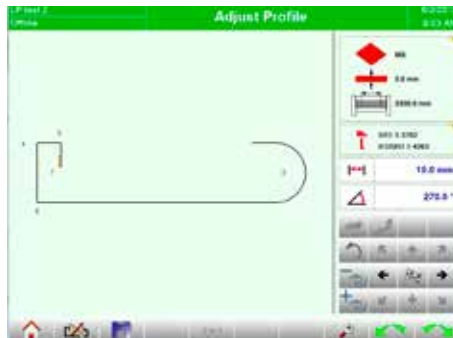

A second option is using the drawing program and create your own profile.



A third programming alternative is Line By Line. Set angles and dimensions and the machine will be ready to fold.



This function automatically calculates the folding sequence, detects collisions and visualises this to the operator.



Shows the folding sequence and how to handle the material.

OPTIONS



SQUARING ARM (not for EGS)

Makes positioning of large and narrow parts easier. Available in two lengths, 1500 mm (59") and 3000 mm (118") for left and/or right hand side.

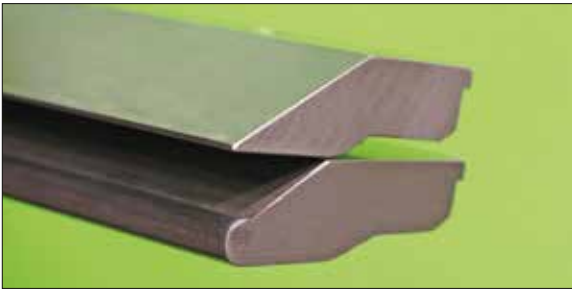

ROUND STRAIGHT RAILS

We offer a numerous different straight rails with radius from 0.75 mm (.029") up to 10 mm (.394"). Recommended for radius bends up to R10 in higher volumes.



MOVEABLE FOOT PEDAL ON RAIL

Allows the operator to move the foot pedal quickly and smoothly along the folding area. Appropriate when folding is done with several tooling stations. Also, the foot pedal rail is considered a great added safety feature when bolted to the floor. When the operator engages the foot pedal, the operator is away from the swinging folding beam.



TOOL CART

Safely store the divided tooling for your CIDAN folder. The tool cart is recommended to decrease the risk of damaging tools and misplacing tools during tool changing. It is possible to store divided rails on the cart and there is room for hand tools for the operators and machine instruction manual. The cart is equipped with lockable wheels and pull handles. Especially recommended if the machine is equipped with the Multifold tooling system.



LASER SAFETY SCANNER

The safety scanner provides extra safety with two modes when operating machine from folding side or gauging side.

The scanner prohibits any person to enter the working area where a collision with the folding beam is possible.

EQUIPMENT

	PIVOTAL 360°	K15	K25	FORMA	PROLINO	PRO	PRO Z	MEGAPRO
Control system								
EasyLink		●	●					
ProLink X	●	○	○	●	●	●	●	●
Tooling								
Standard beam with straight rail	●	●	●		●			
Combi beam tool changer			○	●	○	●	●	
Multifold			○	○		●	●	●
Crowning								
Adjustable crowning	●	●	●	●	●			
Automatic crowning						●		●
Safety features								
Safety bumper on folding beam				○	○	○		○
Laser scanner	○	○	○	○	○	○	○	
Back gauge tables								
EGS		○	○					
AGS	○	○	○	○	○		○	
SBG						○		○
CNC height adjustment	○		○	○		●	○	○
Solid fingers		○ ²		○	○	○	○	○
Squaring arms		○ ²	○ ²	○	○	○	○	○
Others								
Adjustable folding beam speed	●		●/○ ¹	●	●	●	●	●
CNC adjustment of sheet thickness				●		●	●	●
Central lubrication			○	○	○	○	○	●
Optimal eccentric drive OED ^{PAT PEND.}							○	
CNC adjustment of folding center							●	●

● standard, ○ option, ¹depending on length of machine - ²only for AGS

OUR COMPANIES



CIDAN Machinery markets the brands CIDAN and Göteneds and our machines are sold through dealers and agents in more than 30 countries.

For more than 110 years we have produced sheet metal machinery and today we offer a wide machine program worldwide.

All our machines are produced in our production facilities in Sweden.

Our machines are based on our own developments and our own patents; we focus on flexible and simple-to-use solutions of the highest quality.

CIDAN Machinery also manufacture a wide range of coil processing lines and shears. See separate product catalogue.



SWEDEN:
Production, sales & service

CIDAN Machinery Sweden AB
P.O. Box 28
SE-533 21 Götene
Phone +46 (0) 511 245 20
E-mail: info@cidanmachinery.com
www.cidanmachinery.com



USA:
Sales & service

CIDAN Machinery Inc.
611 Highway 74 South, Suite 700
Peachtree City, GA 30269
Phone +1 770-692-7230
E-mail: info@cidanmachinery.com
www.cidanmachinery-america.com



CHINA:
Sales & service

CIDAN Machinery Trading Shanghai Co, Ltd.
No.1155 Yuanda Road Anting Town
Jiading District, Shanghai, 201805
Phone +86(0) 21-39 50 11 08
E-mail: info@cidanmachinery.cn
www.cidanmachinery.cn

DENMARK:
Sales & service
Phone +46 (0) 511 245 20
www.cidanmachinery.dk

MALAYSIA:
Sales
Phone +60 162 169 102
E-mail: info@cidanmachinery.com

Note 1: Machines pictured in the catalogue may be equipped with options
Note 2: Please refer to the website for the latest news and valid product information

CIDAN
MACHINERY

www.cidanmachinery.com

