

www.geka.es

- World leader in punching and shearing solutions
- Worldwide distribution network
- Proven quality, design and craftsmanship
- Continuous innovation
- Complete after sales service
- Great versatility that includes the highest range in accessories and optional equipments in the market
- The only machine fully produced and manufactured in the European Union
- All GEKA machines are special order. GEKA is the only ironworker that you can customize to fit your needs

[www.geka.es](http://www.geka.es)

Distribuidor:

# Hydracrop 165

Where production requires twin operator machines, higher speeds or greater capacity, **GEKA** provides the solution with the **HYDRACROP** range with five working stations: punching, notching, shearing of flat bars, angles and  $\emptyset$  and  $\square$  bars.



HYDRACROP 165	
<b>SHEAR FOR FLAT BARS</b>	
Shearing capacity	750x20 / 400x30 mm
Length of blades	765 mm
Working height	870 mm
<b>SHEAR FOR SECTION IRON</b>	
Shearing capacity	3000 Kn
L at 90 °	205x205x18
L at 45°	70x70x7
<b>SHEAR FOR BARS</b>	
Round bar $\emptyset$	60 mm
Square bar $\square$	60 mm
<b>WITH SPECIAL BLADES</b>	
UPN Profiles	180 mm
IPN Profiles	180 mm
<b>NOTCHING</b>	
Plate thickness	16 mm
Depth	110 mm
Width	58 mm
<b>PUNCHING</b>	
Punching power	1650 Kn
Maximum capacity with quick change and die with gooseneck die holder	$\emptyset$ 40x30 $\emptyset$ 34x34

Capacities are based on a material resistance of 45 kg/mm<sup>2</sup>

## Punching station

The punching station is fitted with an independent cylinder that creates a large, flexible, universal workstation easily adaptable for mounting special tools and "die sets".

-  Cylinder support
-  Split double acting cylinder
-  Limit switches for punch travel setting
-  Generous travel for bending, deep-drawing, forming jobs etc
-  Adjustable generous non-turning guiding
-  Additional guiding for damping of offset forces and protection of hydraulic seals
-  Spindle for fitting of special tools
-  Quick punch change
-  Adjustable material stripper
-  Table with millimetre scales, included in production package
-  Adjustable measuring stop up to 500 mm
-  Gooseneck die-holder for punching channel and section
-  Adjustable bolster locking device X axis
-  Adjustable bolster locking device Y axis
-  Fixing bolt at base of gooseneck

## L cutting angle

Fully aware of the importance of distortion free shearing, GEKA has designed a patented system of a floating upper blade that travels along a rectilinear line and is able to shear angles without any deformation and loss of material (single cut); All GEKA Hydracrop models ensure that distortion problems caused by the conventional radial system are now a problem of the past.

-  Adjustable Support
-  Blade gap adjustment screws
-  Upper shear blade without deformation
-  Upper shear blade guides
-  Safety protection

## Shearing for flat bars

The excellent stability of the monoblock blade-holder, which is controlled at the each end, makes it possible to mount a long upper blade with a proven geometry to obtain optimum shearing quality. The radial system allows a generous cutting capacity as a result of the force multiplier effect.



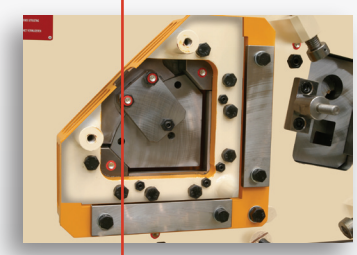
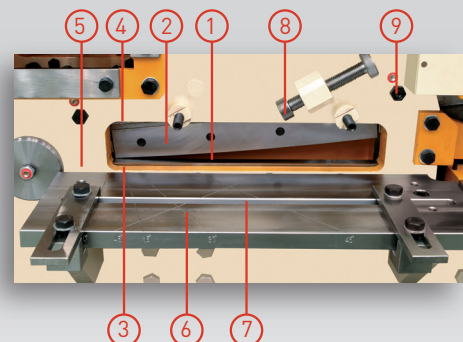



1. Lower blade
2. Upper blade with special geometry
3. Clearance control between shear blades
4. Supplement shearing angle control of upper blade, for shearing without deformation.
5. Adjustable guides 45° right and left.
6. Flat plate/bar shearing table.
7. Slotted guide positioning with coverage of the entire blade length
8. Guide fixing screw
9. Clearance control of blade-holder



## Notching station



This station of the machine has been designed to mount several optional accessories, all of which are normally held in stock.

- Triangular notching at 90°
- Tube notching equipment
- Notching of footings

-  Rectangular punch
-  Material stripper
-  Cross centring bolts
-  Fixing holes special tooling
-  Rectangular notching
-  Table with scaled measuring stops, included in production kit

## Estación de corte de Ø y ∇

The GEKA HYDRACROP machines are fitted as standard with blades for cutting Ø and ∇ bars. Furthermore, this station has been designed bearing in mind the shearing of other sections such as L, I, Z for which a large stock of blades is available.

-  Adjusting bolt and height setting of the guide
-  Blade holding flanges
-  Guide fixing bolts