

Y600 Series Self-powered Treadmill Manual

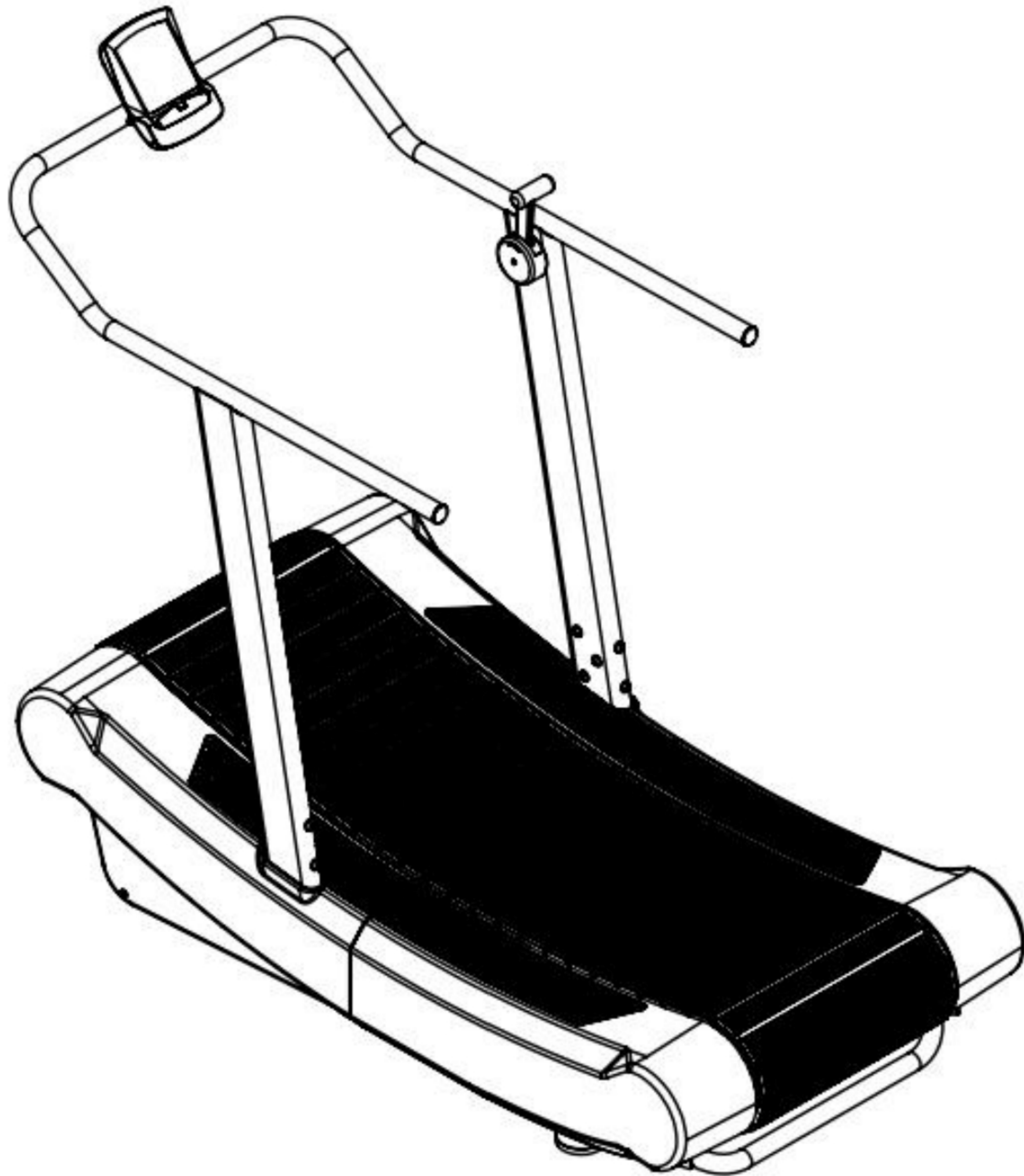

BOLT
FITNESS SUPPLY

VELOCIRAPTOR

Important note

Please keep these instructions

- When using a treadmill, be sure to follow basic precautions, including the following points: Read all instructions before using this treadmill.

It is the owner's responsibility to ensure that all users of this treadmill are notified of all warnings and precautions regarding this equipment.

- The ultimate commercial environmental use of this product. To ensure your safety and protection, please read all instructions before use.

warning!

To reduce the risk of personal injury:

- Incorrect or excessive exercise may cause injury. If you experience any discomfort, including but not limited to chest pain, nausea, dizziness, or shortness of breath, stop exercising immediately and consult a physician before continuing.

- Maintain an appropriate speed when exercising.

- Do not wear clothing that may get caught in any part of the treadmill.

- Always wear sports shoes when using this equipment.

- Just grab the front or side handles and jump your feet on the decorative trims on both sides to get out of the machine.

- Do not jump on a treadmill.

- The treadmill in motion is for single use only.

- Do not use this treadmill if your weigh more than the weight specified in the instruction manual. Failure to comply will void the warranty.
- When cleaning, wipe the surface of the machine thoroughly with a slightly damp cloth. Do not use solvents. (See "Maintenance")
- Children under 14 years of age must not approach this equipment. Teenagers are required to use this equipment under adult supervision.
- This equipment is not suitable for persons with poor physical, perceptual or mental function or lack of experience and the knowledge; if it is to be used, it must be carried out under the supervision of others, and the use of the equipment must be instructed by those responsible for their personal safety.
- Be sure to follow the instructions in the treadmill guide and instruction manual for the intended use of the treadmill.
- Do not use accessories other than those recommended by the manufacturer. Improper use of accessories may result in personal injury.
- Do not use the treadmill if it is not functioning properly, if it has been dropped or damaged, or if it has been immersed in water. Call customer technical support for inspections and repairs.
- Do not use this equipment in locations where temperature cannot be controlled, including but not limited to garages, balconies, pool areas, bathrooms, outdoor carports or outdoors. Failure to comply may void the warranty.

- Excessive exercise may cause serious injury or death.
- When using this product, the user should stand in the middle of the running belt, not too left or right , which will cause the treadmill to run abnormally, machine damaged and personnel injured.

Note !

Consult a physician before using this equipment. Please read the manual before use.

Assembly steps

Unpack

Unpack where you plan to use this equipment. Place the wooden box on a flat surface. It is recommended that you place a protective mat on the floor. Never open the box with the box on its side.

Important note

For each assembly step, make sure that all nuts and bolts are installed in the correct position and that they are partially locked.

Some parts are lubricated in advance to facilitate your assembly and use.

Do not wipe off the lubricant.

If assembly is difficult, it is recommended that you apply a small amount of lubricant.

Warning!

There are several points that must be paid special attention during assembly. Be sure to follow the assembly instructions correctly to ensure that all parts are locked. Failure to follow the assembly instructions properly may cause the parts of the equipment to become unfastened and become loose, making a disturbing noise. To avoid damage to the equipment, be sure to read the assembly instructions and correct them.

Need help?

If you have any questions or missing parts, please contact customer technical support.

Installation tools:

- 5mm Allen wrench
- 8mm Allen wrench
- 10mm Allen wrench
- 14mm open end wrench

Included parts:

- 1 base rack
- 1 left armrest set
- 1 right armrest set

- 1 toboggan
- 1 set of fixed meter
- 1 toboggan
- 1 hardware kit



Product Name: Y600 Self-powered Treadmill

Contents description / quantity

A M8 hexagon socket head bolt /4

B ϕ 8 flat washer /4

C M10 Hex Socket Head Cap Screws /10

D ϕ 10 flat washer /10

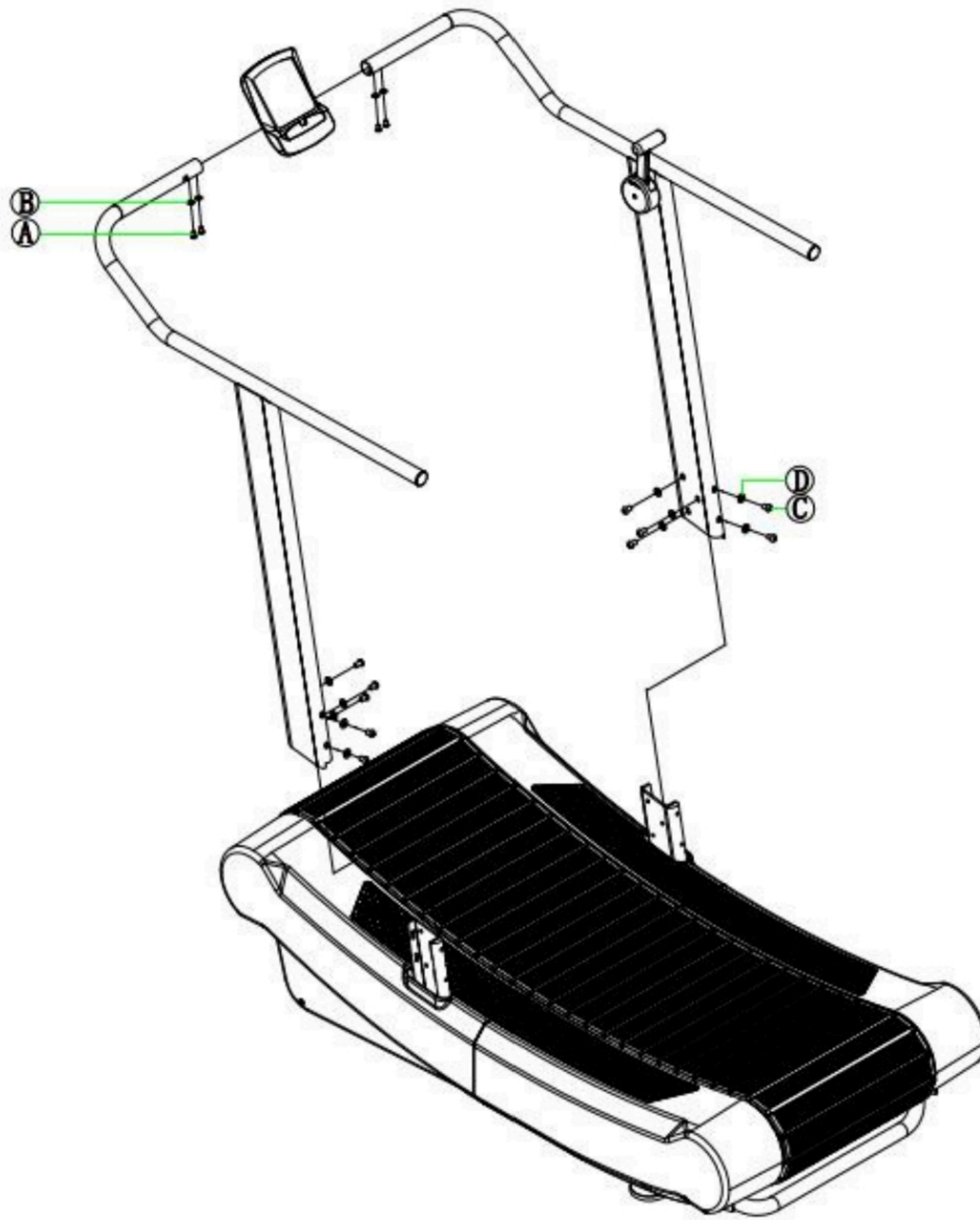

2

Contents description / quantity

E M5 Flat countersunk head hexagon socket bolts /8

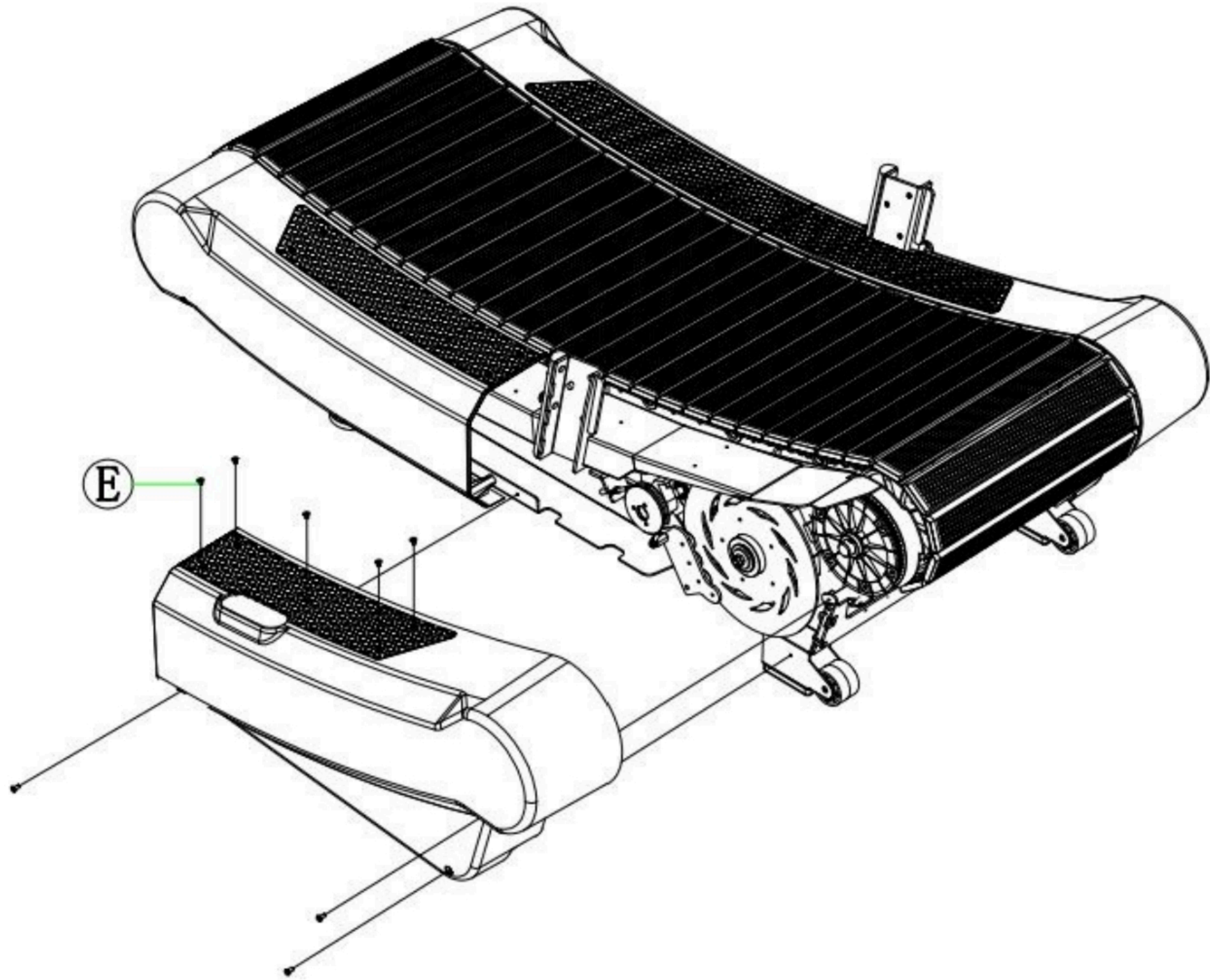

3

Assembly is complete

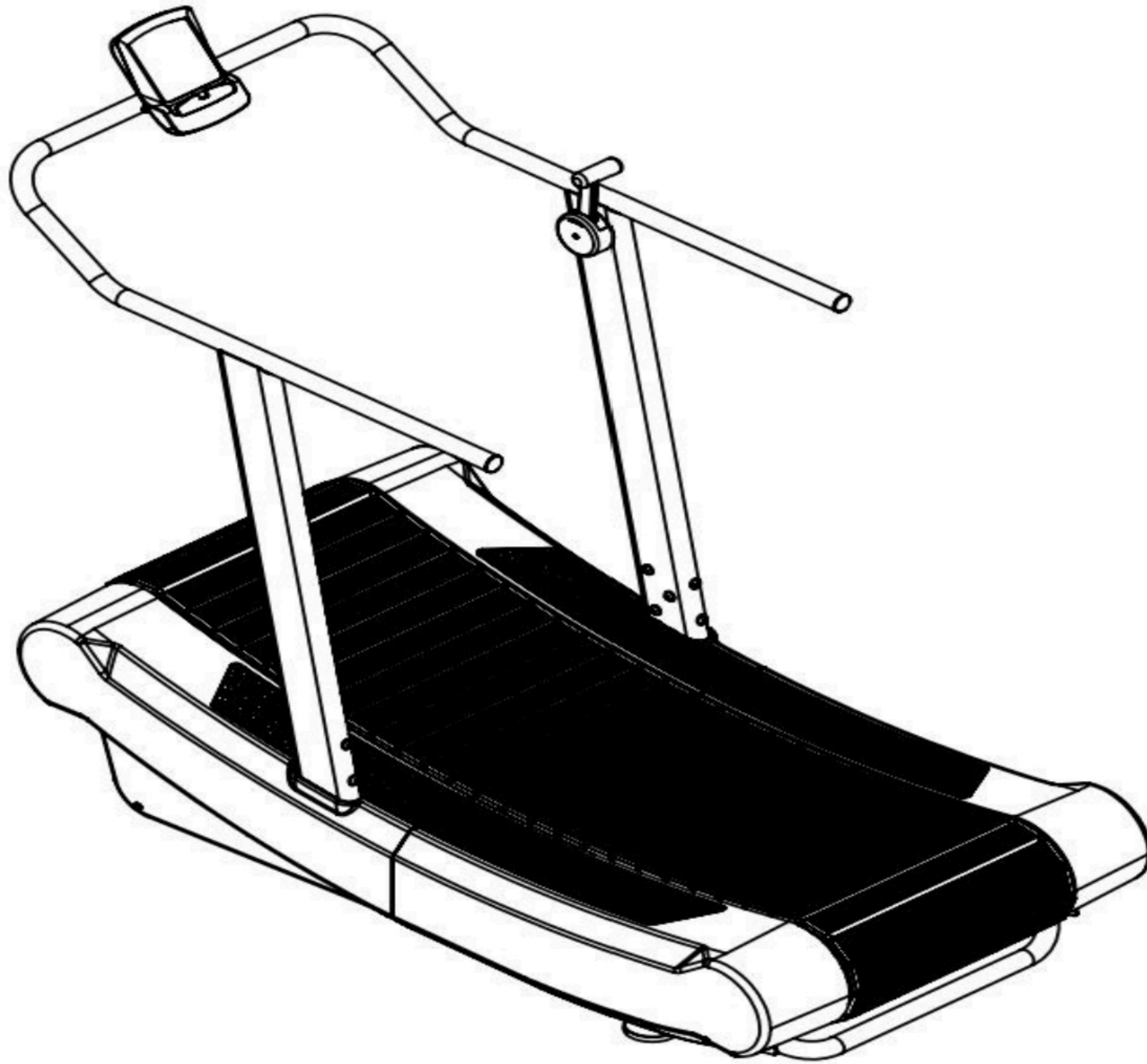

Before the starting

Treadmill position

Place the treadmill on a flat, stable surface that is away from direct sunlight. Strong UV rays can cause plastic to fade. Place the treadmill in a cool, low-humidity area. Behind the treadmill, leave a space at least as wide as the treadmill and at least 2 meters in length. This area must be free of obstacles and provide a clear path for users to leave the machine.

For the convenience of up and down, there should be at least 60 cm of up and down space on both sides of the treadmill, so that users can get up and down from any side. Do not place the treadmill in an area that would obstruct any air vents or vents. The treadmill should not be placed

in a garage, pergola, by the water, or outdoors.

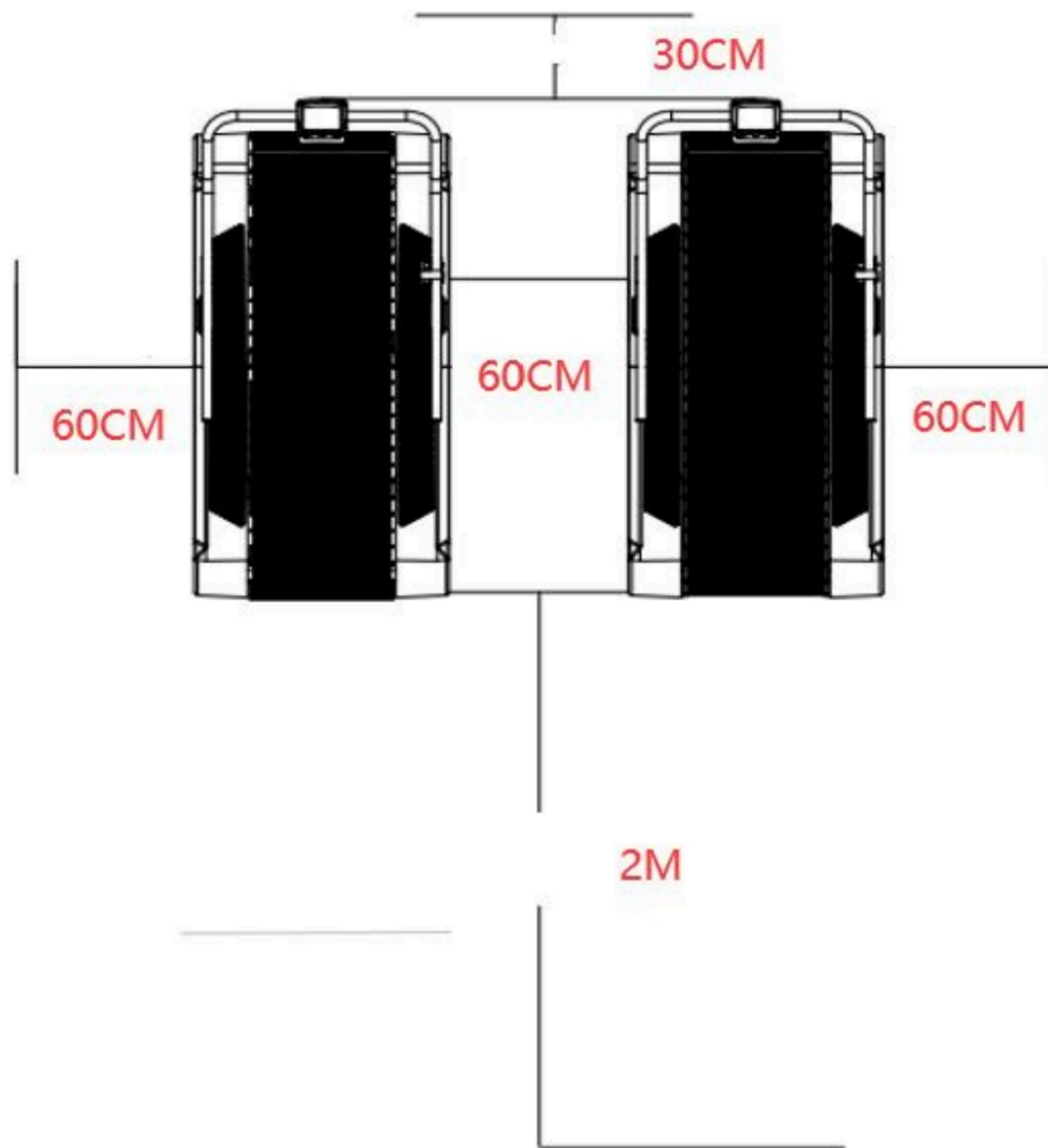

Follows:

Warning!

The treadmill is very heavy. To avoid injury or damage, use caution when moving and seek assistance as needed.

Tightening and guiding of walking belt

After placing the treadmill in the use position, you must check the tightness and center alignment of the walking belt. After the first two hours of use, it may be necessary to adjust the walking belt. Temperature, humidity, and use may cause the walking belt to stretch to varying

degrees. If the walking belt starts sliding while the user is on the walking belt, be sure to follow the instructions below.

1. Locate the two hex head bolts located behind the bearing housing on the rear of the treadmill. The bolts are located at the rear of the two bearing blocks on the rear of the treadmill. These bolts can be adjusted for the rear running roller. Do not make adjustments until the treadmill is turned on. This prevents one side from being too tight.

2. The walking belt should be located between the two sides of the rack, keeping equal distance from both sides. Do not use the treadmill if the walking belt touches one side. Turn the bolts on both sides counterclockwise about one full turn. Push the walking belt between the sides and manually place the walking belt in the center until the walking belt is parallel to the side rails. Tighten the bolts the same amount as when the user loosens, is about one full turn. Check the running belt for damage.

3. Walk on the treadmill at approximately 4.8 kilometers per hour (3 miles) and observe the position of the walking belt. If the walking belt moves to the right, turn the right bolt $\frac{1}{4}$ turn clockwise to tighten it, and loosen the left bolt $\frac{1}{4}$ turn. If the walking belt moves to the left, turn the left bolt $\frac{1}{4}$ turn clockwise to tighten it, and loosen the right bolt $\frac{1}{4}$ turn. Repeat step 3 until the walking belt remains in the center for several minutes.

4. Check the tightness of the walking belt. The walking belt should be very tight. The walking belt should not be sluggish or slippery when walking or running on it.

Please note: Please make sure that the walking belt is centered before using it, as shown in the figure. Please adjust the walking belt until the edge of the walking belt is parallel to the decorative strips on both sides.

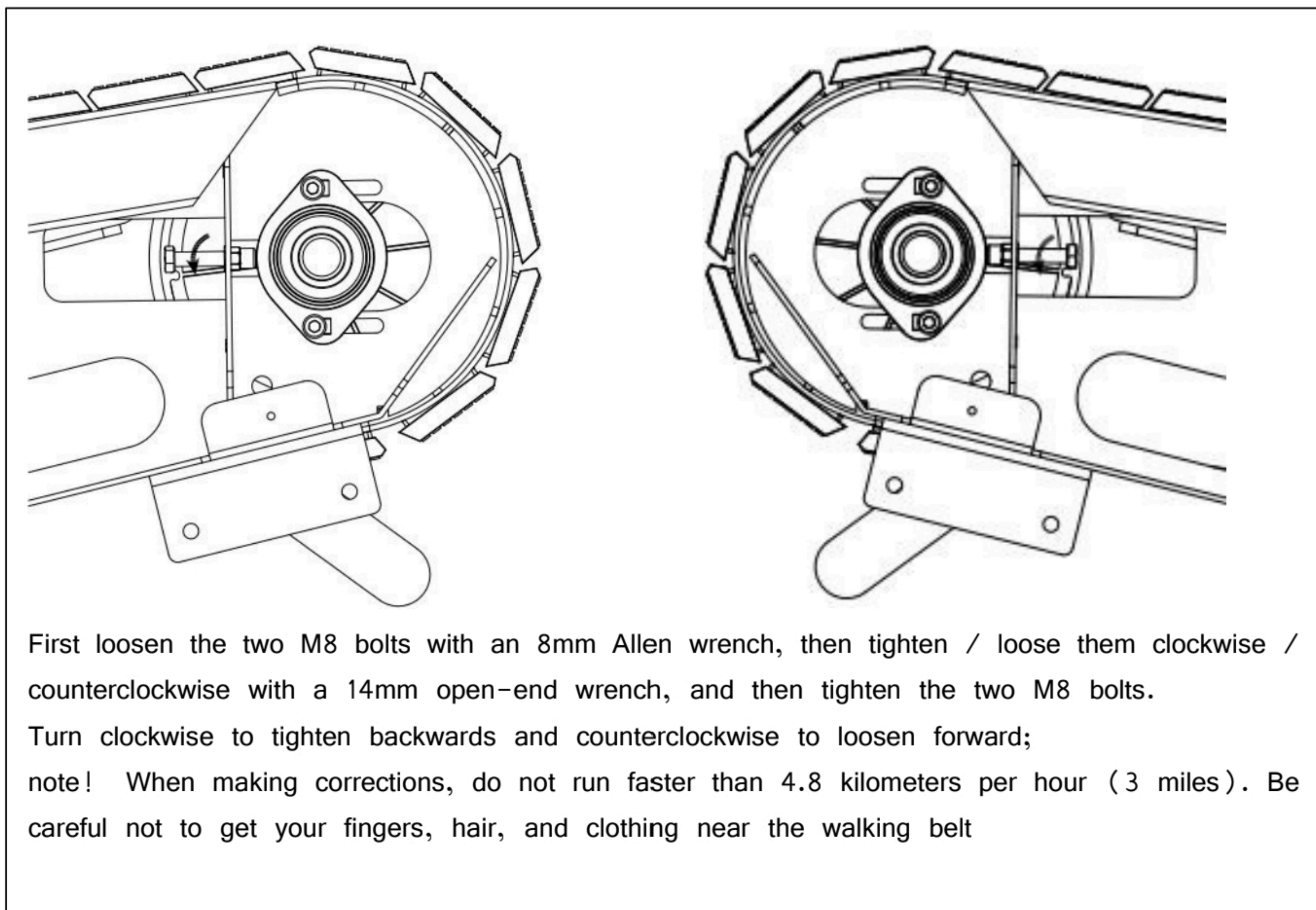

Note!

Do not use a treadmill while performing calibration.

Adjustment of equipment level

Correct adjustment of the support angle is extremely important for the proper operation of the equipment. If the treadmill is unbalanced, it may cause misalignment of the running belt or other problems.

After placing the treadmill in the intended use position, raise or lower one or two adjustment levers located behind the bottom of the rack.

As pictures shown:

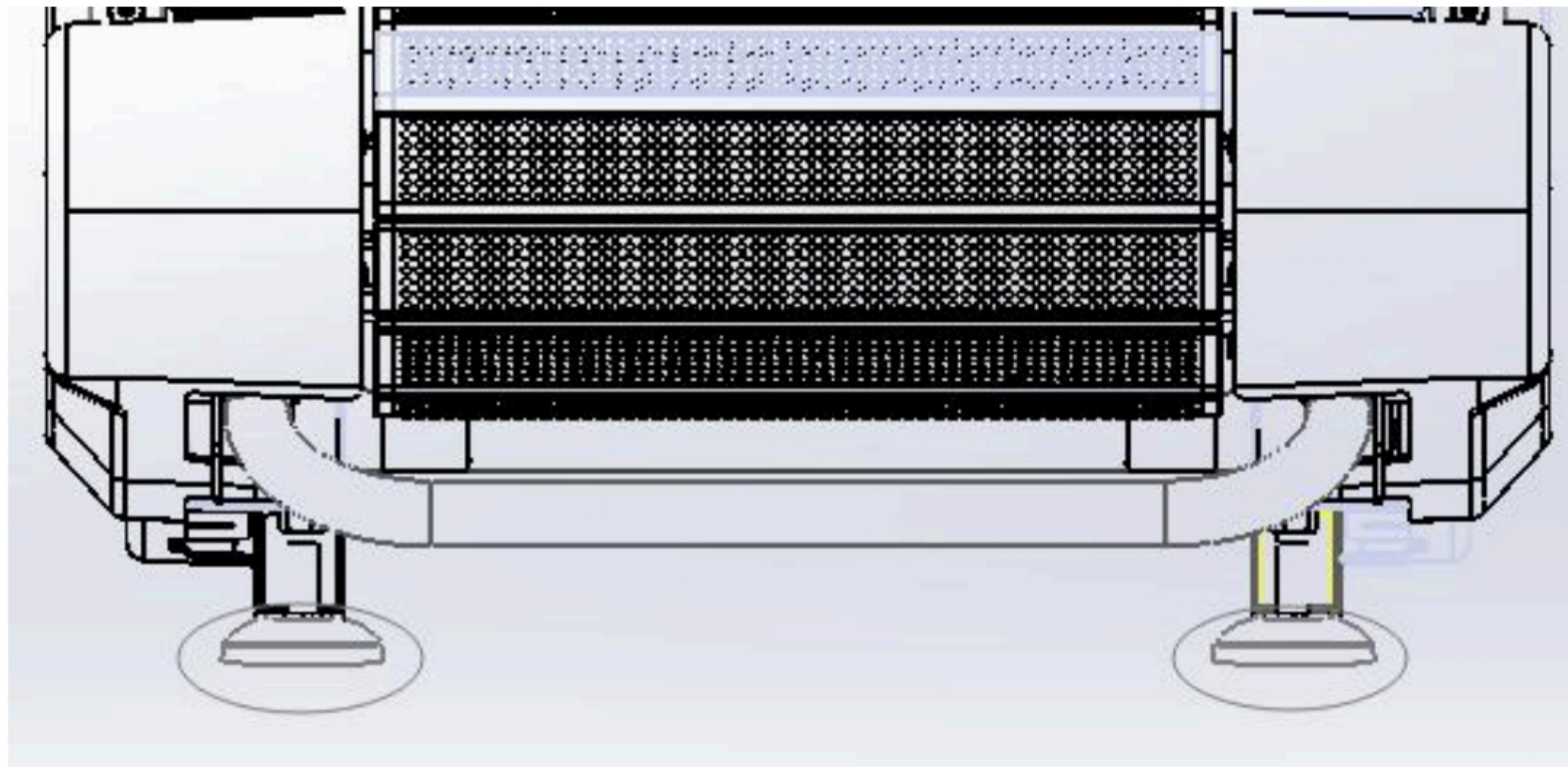

Correct usage

There are four modes that treadmills can be used: pull, walk / sprint, leg coordination and leg agility and leg resistance training. If you need to use the treadmill in pull mode, you can use the handlebar or optional belt to achieve a variety of push and pull exercises.

To use the treadmill in walking / sprint mode, keep your body steady.

If you need to use the treadmill in leg coordination and leg agility mode, you can exercise leg coordination and agility very well, and burn excess fat more effectively.

For resistance from the treadmill in leg resistance training mode. When using this brake, resistance is immediately applied to the walking belt.

Just grab the handles on the front or sides and jump your feet on the decorative trims on both sides to get out of the machine.

The schematic diagram of the tension mode is as follows:

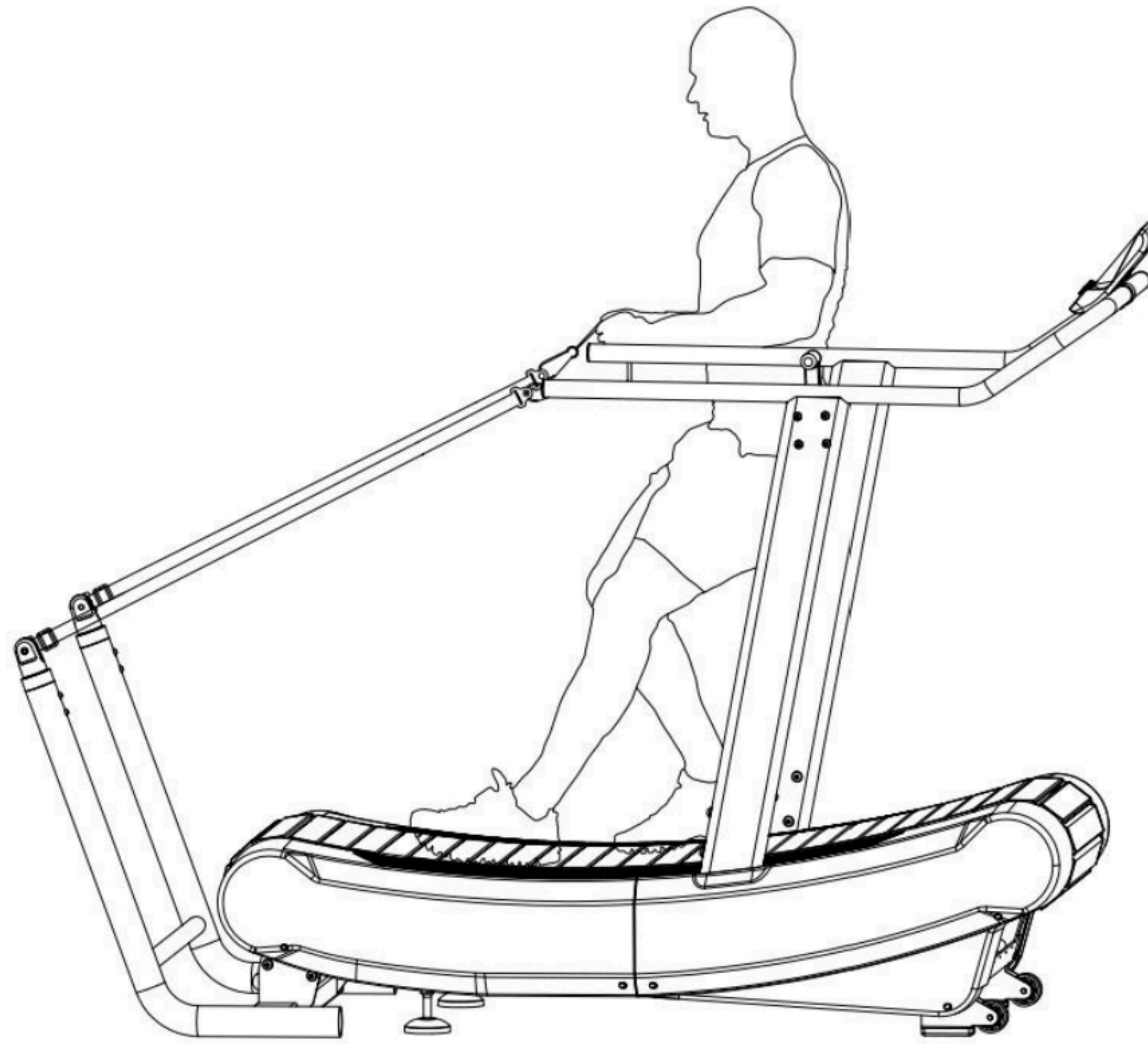

The walking / sprint mode is shown below:

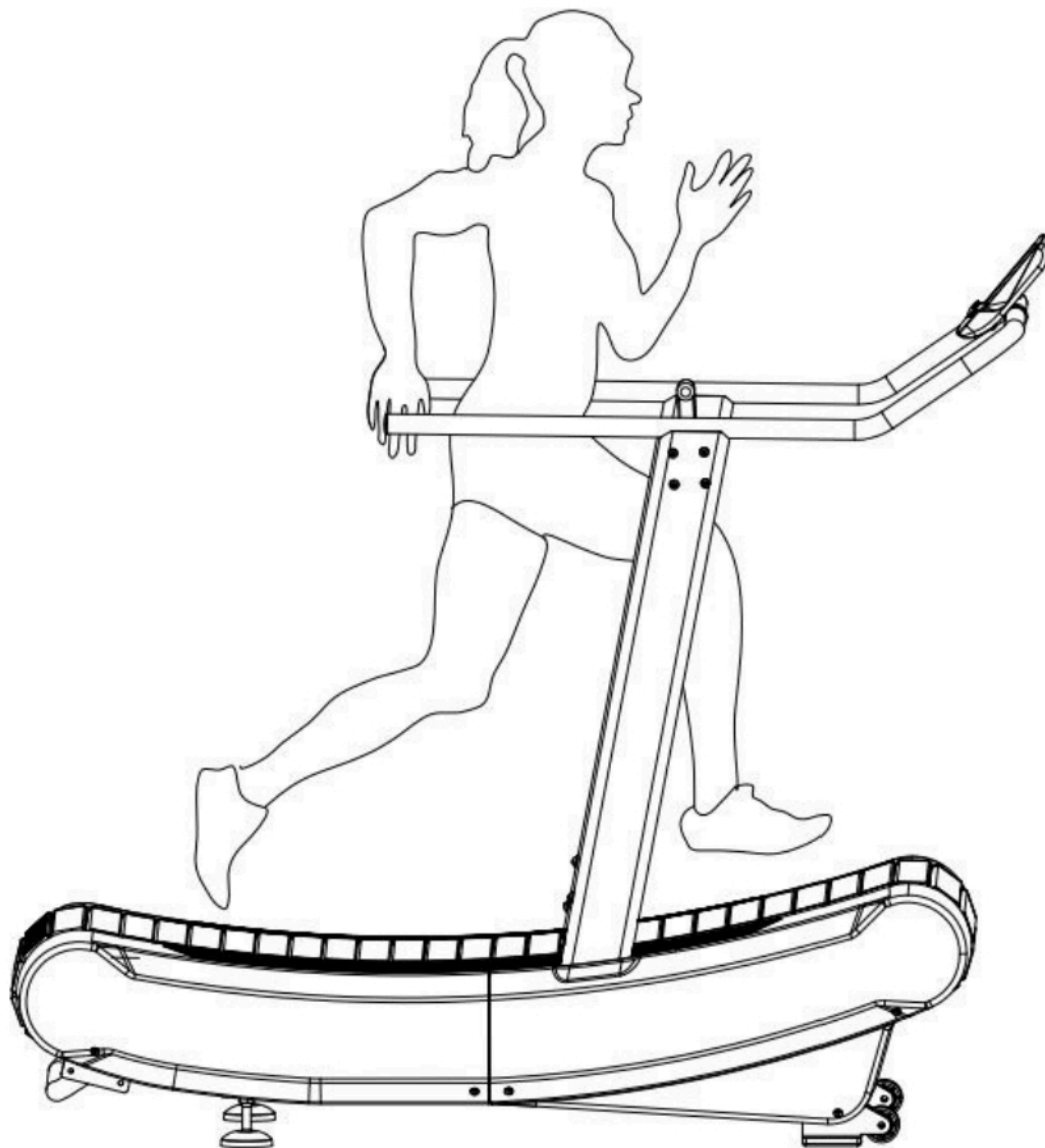

The pattern of leg coordination and leg agility is as follows:

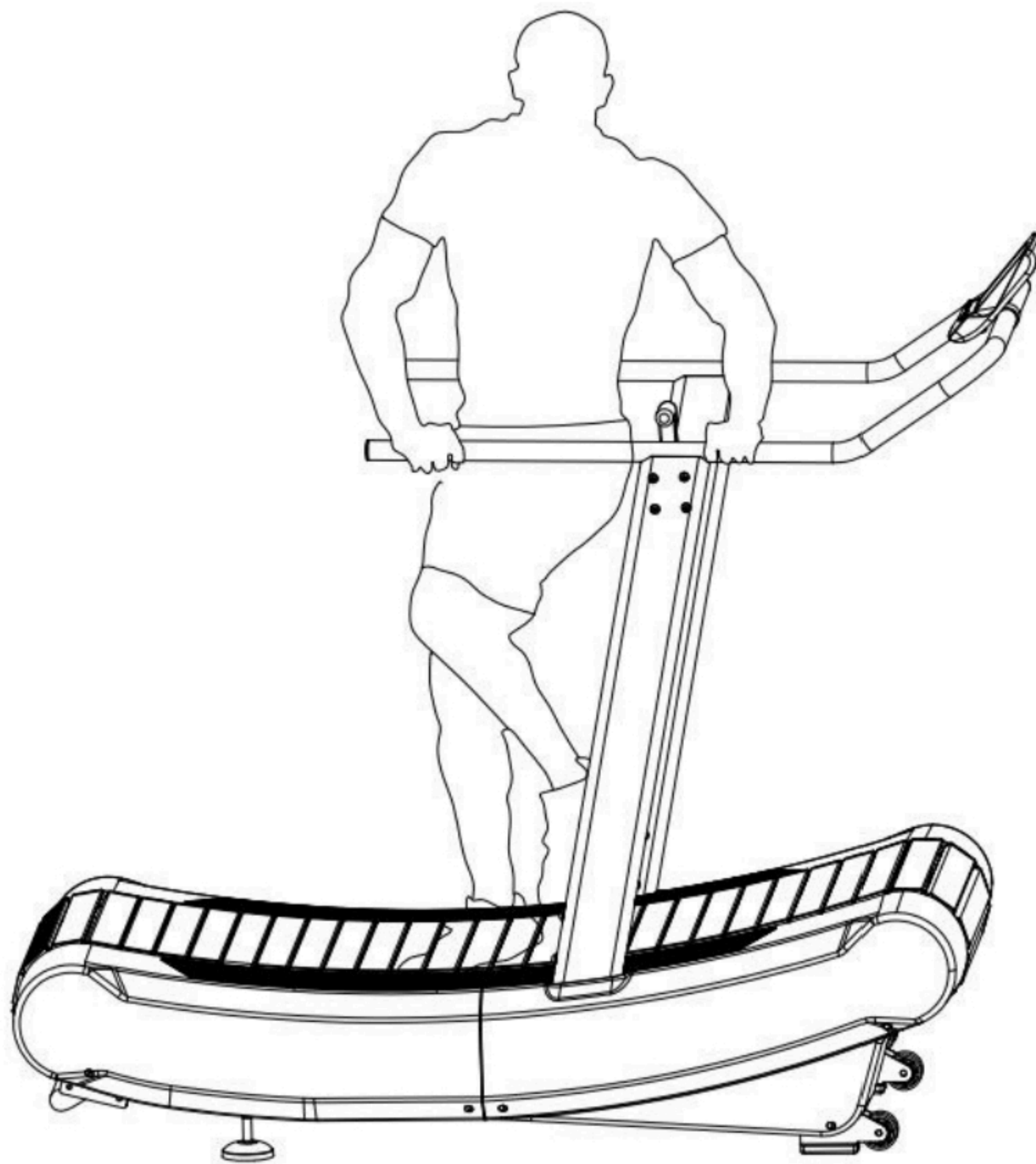

The schematic diagram of the leg resistance training mode is as follows:

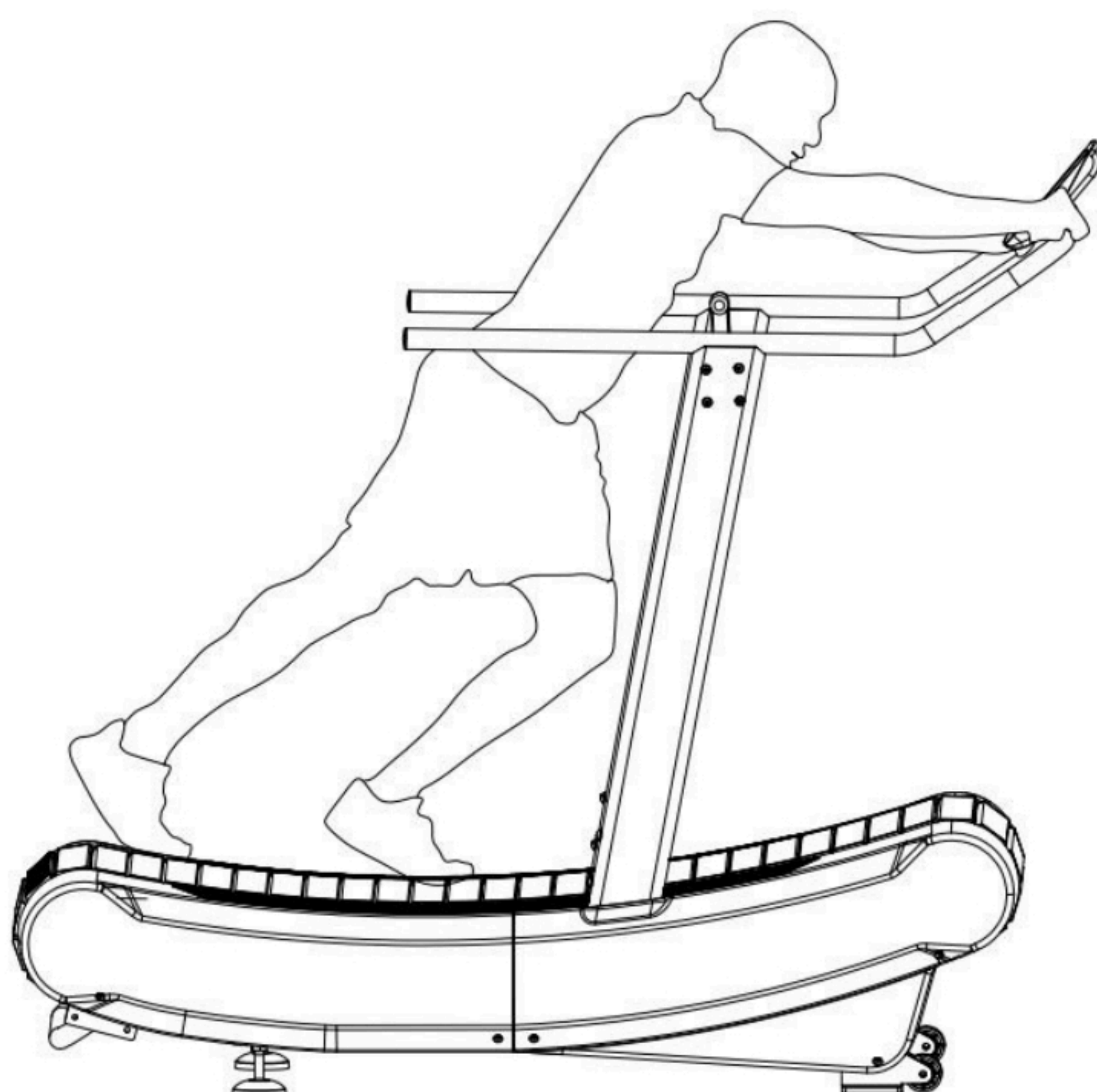

Adjustment of resistance

There are 8 gears on the treadmill.

Speed resistance is designed to simulate the resistance generated when running on a parachute. When using this brake, the resistance increases as the user's speed increases.

Maintenance

1. Disassembly or replacement of any part must be performed by a qualified service technician.
2. Once any equipment is damaged or the parts are worn / broken, it shall not be used continuously. Contact the dealer's after-sales personnel for replacement.
3. Maintain labels and tags: Do not remove labels for any reason. The label contains important advice. If the label is illegible or missing, please contact your dealer and ask for re-posting.
4. Equipment maintenance: Preventive maintenance is to keep equipment functioning normally and safely. Please check the equipment regularly.
5. Confirm that personnel responsible for adjusting or maintaining /

repairing equipment are qualified. The dealer will provide repair and maintenance training on request.

Specifications

Maximum user weight	200kg
Product weight	Aluminium Rubber Belt:165kg
Overall Dimensions (LxWxH)	1850x860x1580 (mm)
Speed limit range	0-20km/h
Running area	1500x430 (mm)

Keep a width of at least 60 cm around unpowered treadmill equipment for easy use and passage. Please note that the ADA recommended wheelchair access width is 1 meter.

Maintenance Schedule

Measures	frequency
Use clean water and mild soap, or other solutions (the detergent should not contain alcohol or ammonia) to clean the entire machine.	every day