



VAPORIX

The Automatic Monitoring System for Active Vapour Recovery



FAFNIR GmbH: Innovation with Tradition. Quality and Satisfaction – made in Germany

Company

The FAFNIR GmbH, based in Hamburg, Germany, develops and manufactures since 1965 filling safety devices, overfill prevention devices, limit signal controllers and continuous level gauging solutions for all types of liquid.

The optimisation of process controls, improvements in cost efficiency and the protection of people and the environment are at the heart of our business.

Our close and trusting relationship with our customers is a key factor in the practice-oriented implementation of innovative ideas and the functionality of our products.



Quality for your satisfaction

To provide all customers with devices of consistently high quality, FAFNIR years ago introduced the internationally-recognised, comprehensive quality management system in accordance with ISO 9001 (EN 29001).

Our expertise in development and manufacturing of explosion-proof equipment is certified by an independent body. All our products are subject to strict FAFNIR quality requirements. We are committed to meeting international standards and applicable EU directives.



VAPORIX

The Automatic Monitoring System
for active Vapour Recovery



VAPORIX-Flow,
VAPORIX-Control
and SECON

Product information

The VAPORIX automatic monitoring system provides information about the functional state of the active vapour recovery and thus complies with the legal requirements.

As an automatic monitoring system for the active vapour recovery VAPORIX serves as protection for people and environment.

Application

The VAPORIX automatic monitoring system is especially designed for use in petrol stations. Due to its modular structure VAPORIX can be used in all known active vapour recovery systems and fuel dispensers.

Features of the FAFNIR technology

- Fulfils the European requirements of immission control
- Independent of the type of the vapor recovery system
- Retrofitting in all common fuel dispensers possible
- No mechanically moving parts
- Independent of media
- Maintenance-free since self-checking
- Connection to all suitable cash systems possible
- Easy start-up and retrofitting
- ATEX and IECEx approval for Zone 0
- TÜV certified

Function

The flow sensor VAPORIX-Flow is based on the calorimetric measuring principle. The medium which flows past a heated sensor element absorbs the

energy and thus cools it. The volume flow can be concluded from the absorbed heat energy. The incoming media parameters (HC and air) are adjusted by

the simultaneous coverage of the HC concentration, i.e. the measured volume flow is captured independently of the media.

System design

Flow Sensor	Measurement evaluation	Display
VAPORIX-Flow Calorimetric flow sensor	VAPORIX-Control Control unit for 2 VAPORIX-Flow	SECON Display for cash area

Installation instructions

VAPORIX-Flow is installed in the vapour recovery pipe before the pump and before any existing control valve and/or condensate separator.

VAPORIX-Flow has to be fixed professionally in the dispenser with clamps and in the flow direction in a vertical position.

Its 8-wire cable (4 m long, standard) is firmly connected to the sensor and must not be shortened. It has to be guided into the dispenser head through suitable cable glands and to be connected to the control unit mounted inside the head. The control unit VAPORIX-Control

has to be mounted outside the Ex-Zone in the head of the fuel dispenser. It contains the supply for two sensors of the type VAPORIX-Flow. As reference inputs, the corresponding pulse outputs of the dispenser computer have to be connected to the VAPORIX-Control.

Technical data
Sensor
VAPORIX-Flow

Operating data

- » Explosion protection:
 Ⓜ II 1 G Ex ia IIB T3 Ga
- » Approvals:
 TÜV 99 ATEX 1509,
 IECEx TUN 08.0008
- » Index of protection IP68
- » Perm. ambient temp.:
 - 40 °C to + 65 °C

Connections

- » Connection to the
 VAPORIX-Control
- » Connecting thread: G 3/8"

Dimensions

- » Installation length: 269 mm

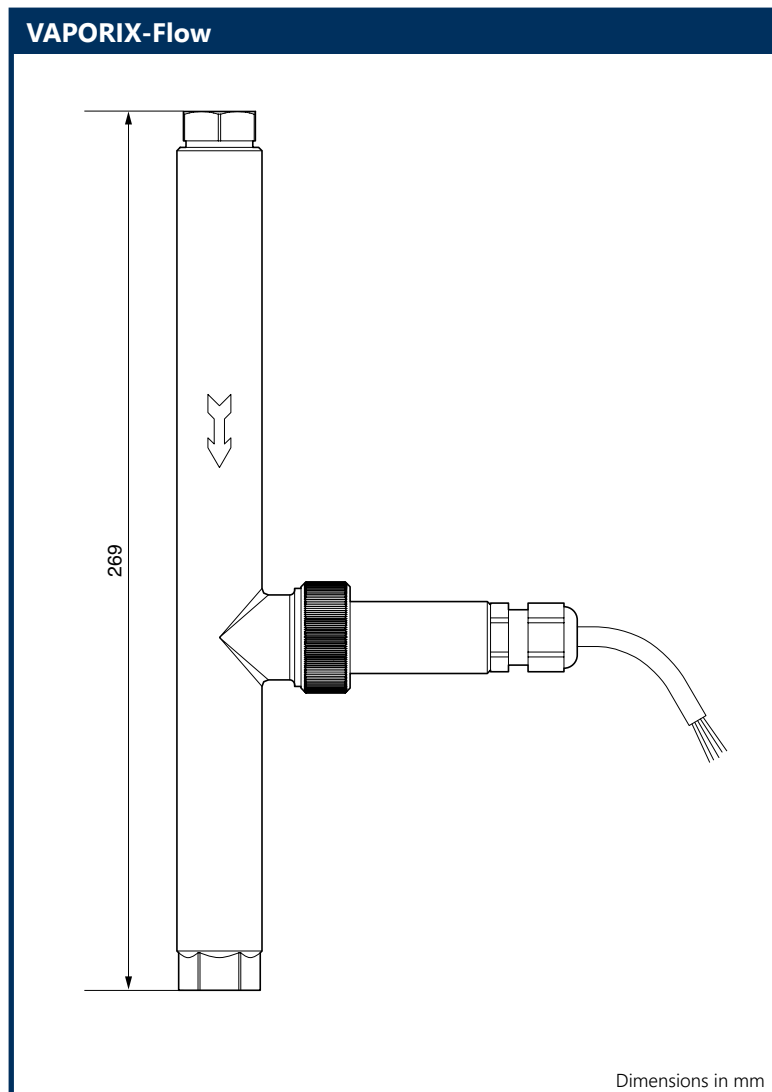

VAPORIX-Control

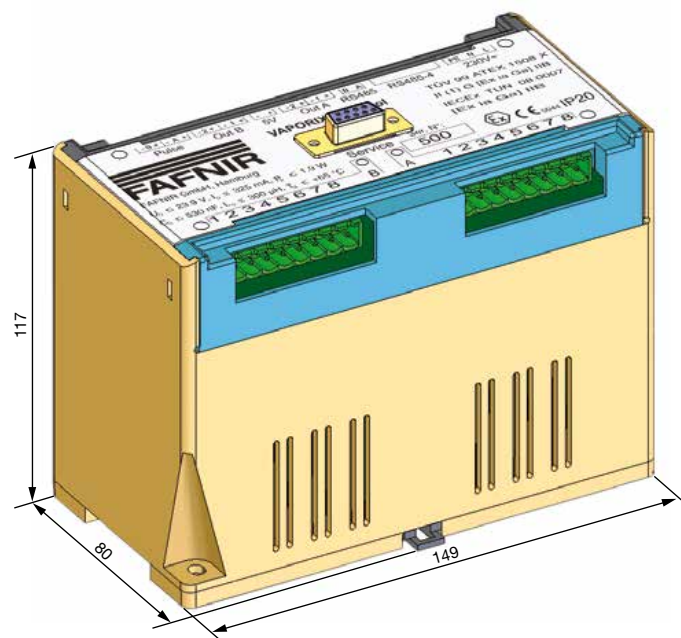

Dimensions in mm

Technical data Control unit VAPORIX-Control

Operating data

- » Explosion protection:
⊕ II (1) G [Ex ia Ga] IIB
- » Approvals:
TÜV 99 ATEX 1508 X
IECEX TUN 08.0007
- » Index of protection IP20
- » Perm. ambient temp.:
- 20 °C to + 65 °C
- » Power supply:
230 V alternating current,
appr. 20 W;
Optional:
115 V alternating current
- » Safe max. Voltage:
 $U_m = 253 \text{ V}$

Connections

- » Power supply: 230 V ~ ...
- » Pulse inputs: rectangular
signal with 5...24 V pulse
height, max. 1 kHz,
duty factor 20...80 %
- » Pulse valency:
100 pulses / litre
default setting;
Optional:
33 / 50 / 132 / 200 pulses / litre
default setting
- » Outputs: 2 x galvanically
isolated transistor outputs
max. 30 V, 100 mA

» Interfaces:

- 1 x RS-232 (service),
- 1 x RS-485 4-wire
(dispenser computer),
- 1 x RS-485 2-wire
(SECON, DOMS, POS)

VAPORIX – Order code

Designation	Description	Order number
VAPORIX-Flow		908247
VAPORIX-Control (Basic)	(Please specify country code, for example: 0049 for Germany)	908360
VAPORIX-Service Dongle		908249
SECON-Vap	Display incl. plug-in power supply	908324
SECON-Vap	Display incl. 12 V power supply for DIN rail mounting	908382

Condensate Separator

The Condensate Separator
for Vapour Recovery Systems



Product information

The condensate separator is designed for fuel dispensers to be retrofitted with decentralized active vapour recovery systems. The condensate separator collects large quantities of condensate and converts it back into a gaseous state.

It is designed for the requirements of vapour recovery systems at petrol stations.

The application of the condensate separator increases the lifetime of the pumps and improves the smooth running of the system. A condensate separator should be a part of every vapour recovery system.

Technical description

Condensate and liquid residues transported by the vapour recovery flow are collected in the condensate separator. They are collected on the bottom. From here they are converted back into a gaseous state by the passing volume flow during the operation. The optimal vapour flow within the condensate separator leads to a quick dissolution of the condensed residue.

Features of the FAFNIR technology

- Ideal for retrofitting existing equipment
- Robust construction
- Maintenance-free
- Easy installation
- Cost effective
- Maximum protection of the vapor recovery pumps
- Improves the smooth running of vapor recovery pumps

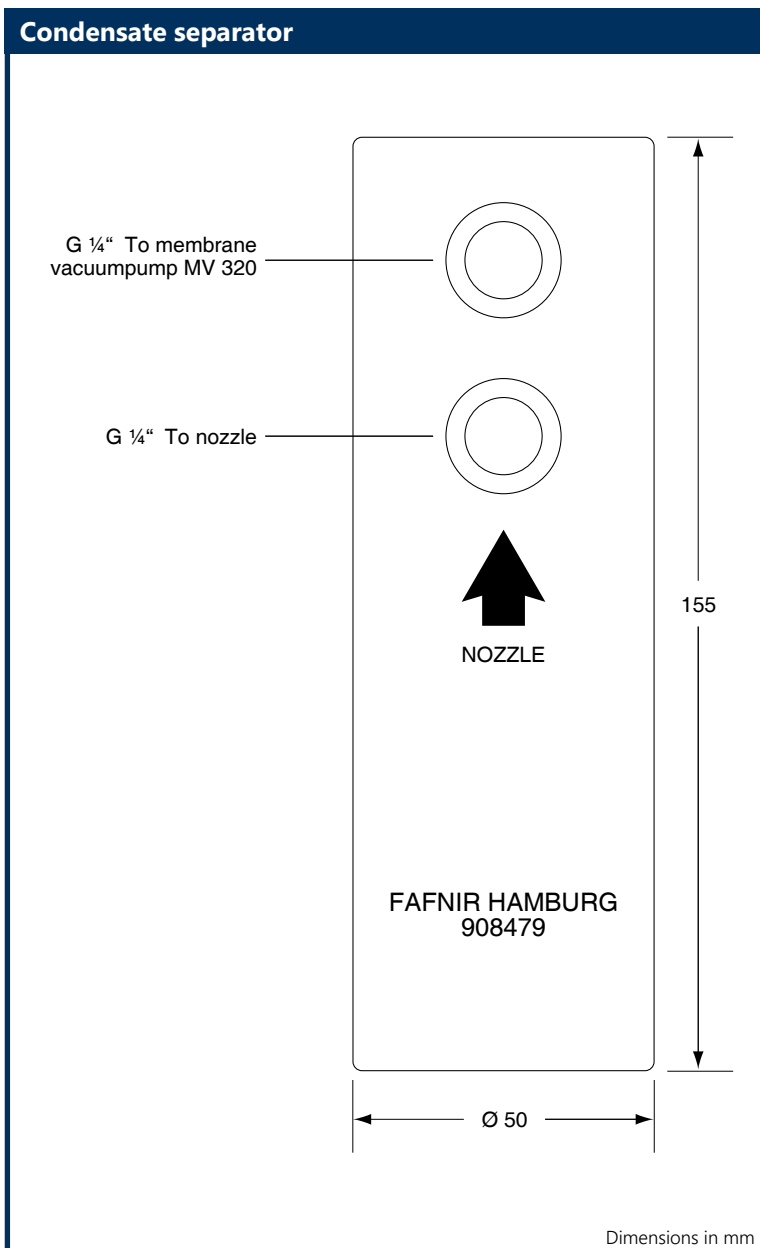

Installation instructions

The condensate separator is integrated into the vapour recovery system between the nozzle and the vapour recovery pump.

In order to guarantee a proper operation the following installation instructions should be observed:

- » The installation position of the condensate separator must always be vertical, i. e. in an upright position (see the drawing).
- » The supply connections must not be interchanged.
- » To fasten the condensate separator standard pipe clamps can be used, if necessary.
- » After installation the system has to be newly calibrated.

Maintenance Instructions

If the condensate separator is used according to its intended purpose, it is generally maintenance-free.

Technical data

- » Connections: G 1/4" inner thread
- » Material: completely made of stainless steel 304, wall thickness 1 mm, welded gas-tight
- » Dimensions: H 155 x Ø 50 [mm]

Condensate separator – Order Code

Designation	Order number
Condensate Separator for Vapour Recovery Systems	908479

VAPORIX-PCM

The pulse correction module for vapour recovery systems

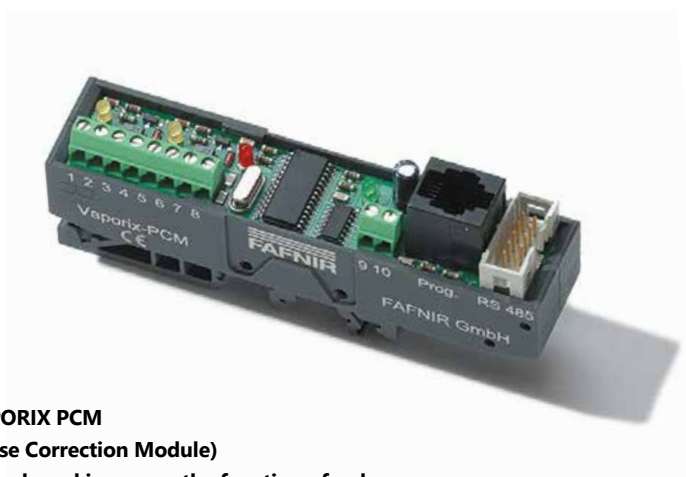

VAPORIX PCM
(Pulse Correction Module)
extends and improves the function of pulse-controlled vapour recovery systems.

Product information

VAPORIX-PCM is a control module for pulse controlled vapour recovery systems which corrects physically caused drift effects of the vapour recovery rate (e.g. through temperature variations or swelling hoses and seals).

Function

With the help of its micro-controlled electronics VAPORIX-PCM reverts to the established history data base inside the VAPORIX-Control. This history-based knowledge enables a highly effective corrective control of the vapour recovery.

All influences that could affect the vapour recovery are included. The result is an excellent corrective control that exactly diagnoses failures of the vapour recovery.

Features of the FAFNIR technology

- Makes a difference between physically based fluctuations and real errors and thus enables the proper repair according to European directives
- Suitable for both new installations and retrofit
- Independent of manufacturer-specific features
- Easy installation and retrofitting
- Space saving due to very small dimensions

Process flow

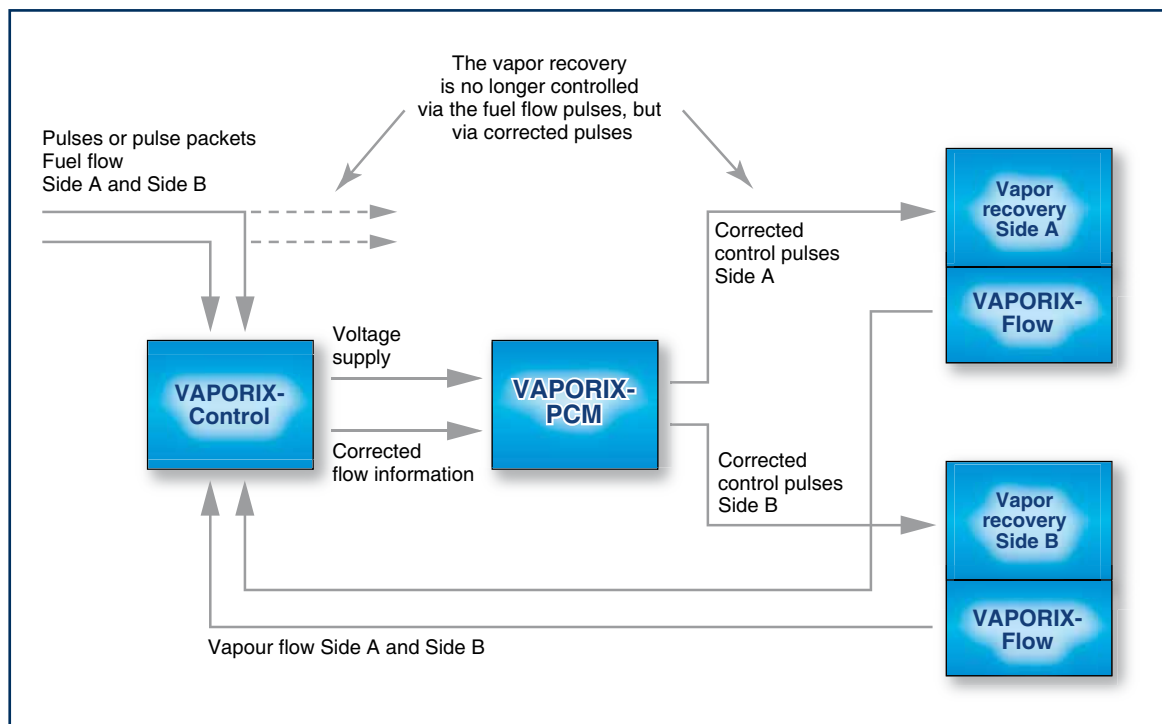

Technical data VAPORIX-PCM

Supply

- » 5 V_{DC} and ≤ 30 mA (from VAPORIX control), internal reverse polarity protection up to 30 V_{DC}, screw terminal for max. 1 mm². Connecting cable to VAPORIX-Control is included

10 mA_{DC} max. switching voltage 28 V_{DC}

- » internal reverse polarity protection up to 30 V_{DC}
- » Screw terminal for max. 1 mm²
- » Display of pulse generation by yellow LED

Serial port

- » RS485, 4-wire, 10-pin connector, cable for VAPORIX-Control connection is included

Operation indication

- » green LED

Pulse outputs per side

- » 1 x TTL compatible (4.7 V / 2 mA), short-circuit proof
- » 1 x Optocoupler for generating galvanically isolated pulses via external voltage supply, collector and emitter open, max. switching current

Pulse frequencies

- » 2.0 Hz ... 200.00 Hz
- » Corresponds to 2.4 l/min (at 50 pulses/l) to 60.0 l/min (at 200 pulses/l)

Fault indication

- » red LED

Dimensions

- » H 105 x W 24 x D 47 [mm]

Housing

- » Module carrier for DIN rail mounting

VAPORIX PCM – Order code

Designation	Order number
VAPORIX-PCM	
for the corrective control of active vapour recovery	908259



FAFNIR GmbH
Schnackenburgallee 149 c
22525 Hamburg, Germany

Phone: +49/40/39 82 07-0

Fax: +49/40/390 63 39

E-Mail: info@fafnir.com

Internet: www.fafnir.com