

Product Information

Transmitter

Standard Signal Transmitter PMT50-1



PROFIBUS

- **Signal conditioning – Linearisation – Characteristic adjustment**
- **Input for standard signals 0/2..10 V and 0/4..20 mA**
- **Measuring range programmable**
- **Linearisation and characteristic adjustment programmable via 32 bases**
- **Automatic input fault detection**

Characteristics

The programmable universal transmitter PMT50 operates with analog input signals. The device convert input signals to analog output 0/4..20 mA; 0/2..10 V DC. Optional a serial interface is available. The device offers a linearisation function for any sensor curves and a simulator function. The integrated transmitter supply 24 V DC max. 30 mA allows the feeding of 2-and 3-wire transmitter. 4 alarm outputs for monitoring and controlling are available.

Technical data

Power supply

Supply voltage : 230 V AC ±10 %
 : 115 V AC ±10 %
 : 24 V DC ±15 %

Power consumption : < 5 VA

Operating temperature : -10..+55 °C

CE – conformity : EN 61326-1:2013; EN 60664-1:2007

Input : 0/2..10 V, 0/4..20 mA

Ri : current 10 Ω

: voltage 10 kΩ

Accuracy : < 0.1 %, ±1 Digit

Transmitter supply : 24 V DC max. 30 mA

Fault detection : break of wire (only 4 mA / 2 V)

Outputs

Alarm outputs : relay SPDT
 < 250 V AC < 250 VA < 2 A cos φ ≥ 0,3
 < 300 V DC < 40 W < 2 A

Analog output : 0/4..20 mA burden ≤ 500 Ω,
 0/2..10 V burden > 500 Ω, isolated
 output burden depending

Fault indication : break of wire in the measuring circuit
 → analog output programmable
 0 mA, < 3.6 mA or >21.5 mA
 → alarm relay(s)
 min. or max. programmable

Bus system

Modbus : RS485, RTU or ASCII
 max. 38400 Baud

Profibus : Profibus DP

Connection : 9pol. D-SUB connector in the front

Display : graphic-LCD-Display, 128 x 64 Pixel,
 with white LCD backlight

Case : Polyamide (PA) 6.6 , UL94V-0
 acc. to DIN EN 60715, DIN rail TS35

Weight : approx. 450 g

Connection : screw terminals 0.14..2.5 mm²
 AWG 26..AWG14

Protection class : case IP30, terminals IP20 acc. to BGV A3

Dimensions

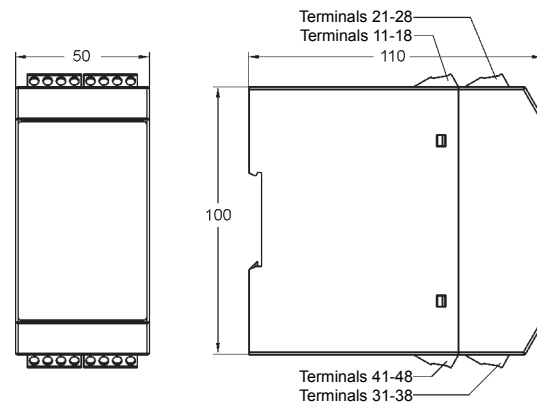

Continue next page

Product Information

Connection diagram

Model PMT50-1

Standard signals 0/4..20 mA, 0/2..10 V

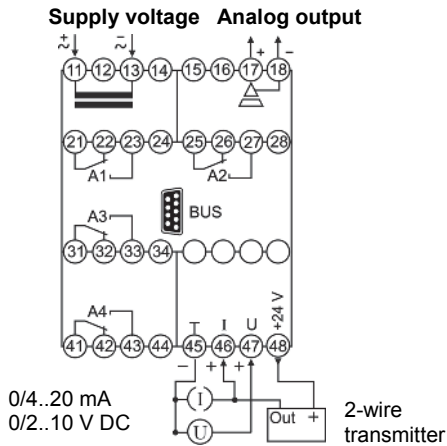

Ordering code

1. 2. 3. 4. 5. 6.
 PMT50 - - - - - -

1. Model/input	
1	standard signals 0/4..20 mA, 0/2..10 V DC
2. Analog output	
AO	0/4..20 mA, 0/2..10 V DC, isolated
3. Alarm outputs	
00	not installed
2R	2 relay outputs, A1, A2 SPDT
4. Alarm outputs/BUS configuration	
00	not installed
2R	2 relay outputs, A3, A4 SPDT
MB	Modbus RTU/ASCII, RS485
PB	Profibus DP
5. Supply voltage	
0	230 V AC, ± 10 % 50-60 Hz
1	115 V AC, ± 10 % 50-60 Hz
5	24 V DC, ± 15 %
6. Options	
00	without option

Bus connection

Modbus		
PIN	Signal	EIA/TIA-485 name
5	D1	B / B'
9	D0	A / A'
1	Common	C / C'
Profibus		
3	RxD / TxD-P	
5	DGND	
6	VP / +5V max. 10 mA	
8	RxD / TxD-N	

9 pole D-Sub connector in the front

