

# Truflo® — TKW Series (Blind) In-Line Paddle Wheel Flow Meter Sensor

**ICON**™ Corrosion-Free  
PROCESS CONTROLS Instrumentation Equipment

Flow | Total | Pulse | Voltage | 4-20mA



**truflo**®

**TKW**



# Truflo® — TKW Series (Blind) In-Line Paddle Wheel Flow Meter Sensor

- ✓ No Programming | Quick Installation
- ✓ Industry's Highest Accuracy:  $\pm 0.5\%$
- ✓ Lifetime Warranty\*

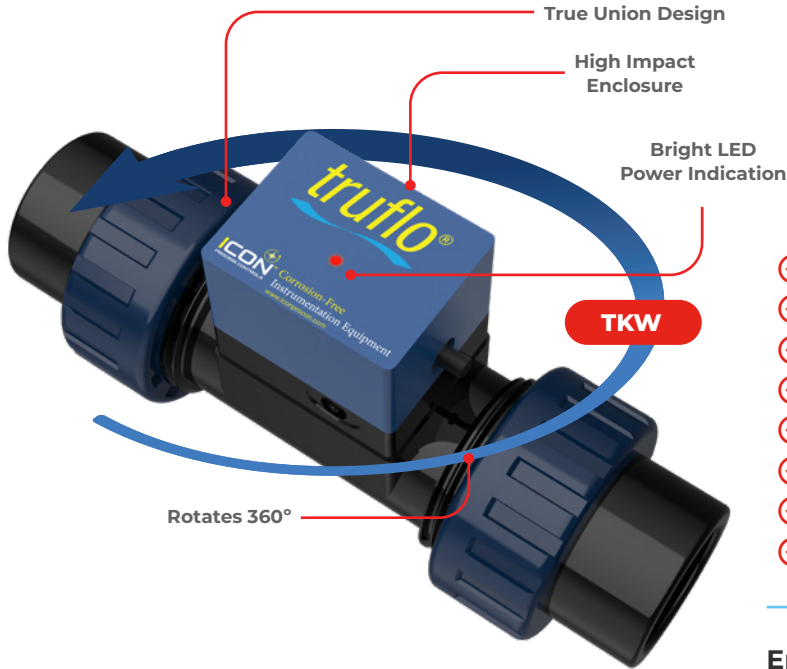

✓ **Unbeatable Warranty**



- ✓ Pulse | Voltage | 4-20mA Outputs
- ✓ Flow | Total
- ✓ Revolutionary ShearPro® Paddle Wheel Design
- ✓ Low Pressure Drop
- ✓ NEMA 4X | IP 66 Protection
- ✓ Password Protected Security
- ✓ True Union Design ½" - 2"
- ✓ Flange Connection 3" - 4"

## Engineered for accuracy, ruggedness and longevity

The Truflo® TKW Series digital in-line flow meter sensors are easy to install with exceptional guaranteed long-life performance. They are highly repeatable, extremely rugged sensors that offer outstanding value and require no scheduled maintenance.

The TKW Series has a process-ready output signal with a wide dynamic flow range of 0.3 to 33 ft/s | 0.1 to 10 m/s. The sensor measures liquid flow rates in full pipes.

TKW Series flow meters are offered in a variety of materials and are available from ¼" - 4" pipe sizes. The many material choices, including PVC, PP, PVDF and 316 SS make this model highly adaptable and chemically resistant to many corrosive liquid process applications.

The TKW Series flow meter bodies (PVC, PP, PVDF) are true-union designed up to 2" just as any true-union ball valve is designed. 3" - 4" versions are flanged. This blind unit comes completely pre-programmed with a bright LED power indicator.

\* The Truflo® TKW Series also comes equipped with a lifetime warranty on the paddle wheel assembly.

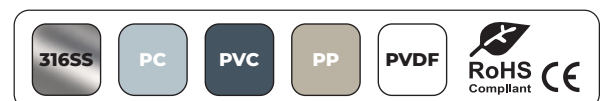
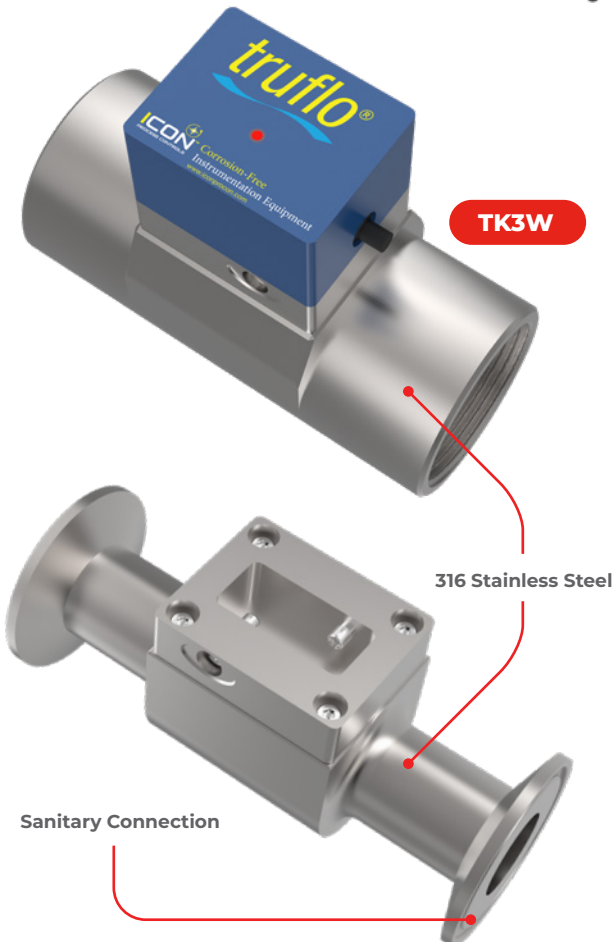

# Truflo® — TKW Series (Blind) In-Line Paddle Wheel Flow Meter Sensor

## New ShearPro® Design

- ✓ Contoured Flow Profile
- ✓ Reduced Turbulence = Increased Longevity
- ✓ 78% Less Drag than Old Flat Paddle Design\*

\*Ref: NASA "Shape Effects on Drag"



## Tefzel® Paddle Wheel

- ✓ Superior Chemical And Wear Resistance vs PVDF

## Zirconium Ceramic Rotor | Bushings

- ✓ Up to 15x the Wear Resistance vs. Regular Ceramic
- ✓ Integral Rotor Bushings Reduce Wear and Fatigue Stress

## ShearPro® Through-Pin Design

- ✓ Eliminates Finger Spread
- ✓ No Lost Paddles
- ✓ Increased Temp. Rating
- ✓ 360° Housing Protects Rotor

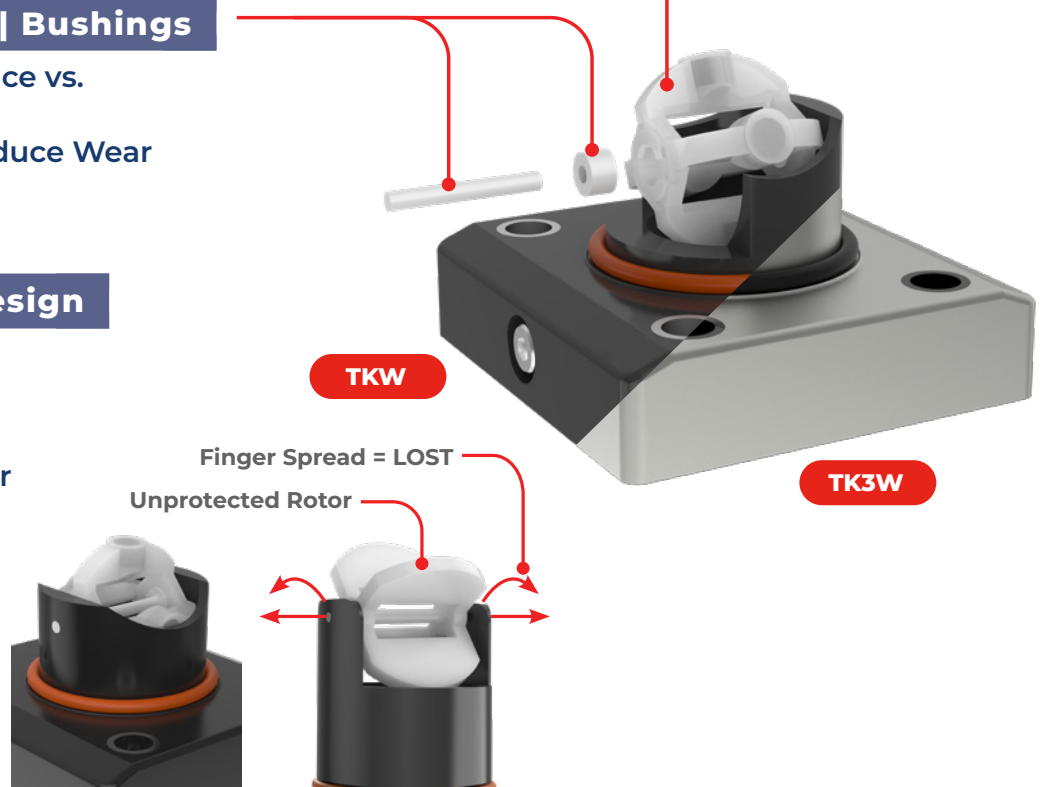

ShearPro® vs. Competitor 'A'

## Wiring Diagram

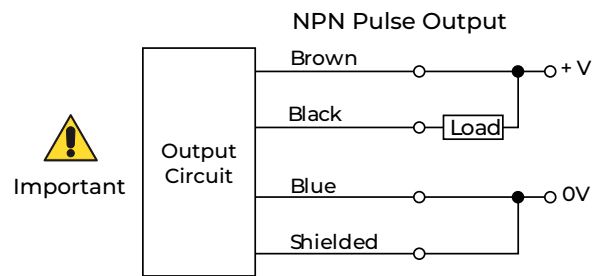
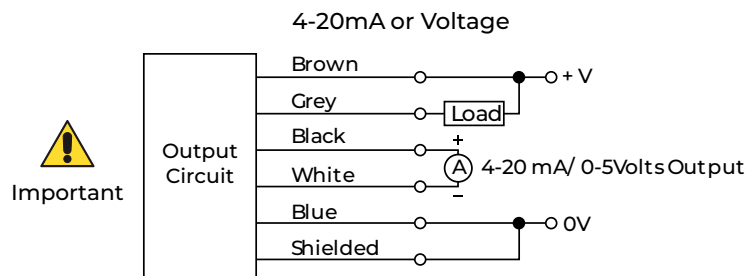

# Truflo® — TKW Series (Blind)

## In-Line Paddle Wheel Flow Meter Sensor

### Specifications

General		
Operating Range	0.3 to 33 ft/s	0.1 to 10 m/s
Pipe Size Range	¼" to 4"	DN08 to DN100
Linearity	±0.5% of F.S @ 25°C   77°F	
Repeatability	±0.5% of F.S @ 25°C   77°F	
Wetted Materials		
Sensor Body	PVC (Dark)   PP (Pigmented)   PVDF (Natural)   316SS	
O-Rings	FKM   EPDM*   FFKM*	
Rotor Pin   Bushings	Zirconium Ceramic   ZrO <sub>2</sub>	
Paddle   Rotor	ETFE Tefzel®	
Electrical		
Frequency	49 Hz per m/s nominal	15 Hz per ft/s nominal
Supply Voltage	9 to 30 VDC ±10% regulated	
Supply Current	<1.5 mA @ 3.3 to 6 VDC	<20 mA @ 6 to 24 VDC
Max. Temperature/Pressure Rating - Standard and Integral Sensor   Non-Shock		
PVC	180 psi @ 68°F   40 psi @ 140°F	12.5 bar @ 20°C   2.7 bar @ 60°C
PP	180 psi @ 68°F   40 psi @ 190°F	12.5 bar @ 20°C   2.7 bar @ 88°C
PVDF	200 psi @ 68°F   40 psi @ 240°F	14 bar @ 20°C   2.7 bar @ 115°C
316 SS	Consult Factory	
Operating Temperature		
PVC	32°F to 140°F	0°C to 60°C
PP	-4°F to 190°F	-20°C to 88°C
PVDF	-40°F to 240°F	-40°C to 115°C
316 SS	-40°F to 300°F	-40°C to 100°C
Outputs		
TKW Series	NPN Pulse   Voltage   4-20mA Outputs	
Standards and Approvals		
CE   FCC   RoHS Compliant		

See Temperature and Pressure Graphs for more information

\*Optional

### K-Factors for TK Series

Size	LPM	GPM
¼"	547	2079
⅜"	300	1140
½"	124	471
¾"	72	274
1"	54	171
1½"	19	72
2"	10.3	39
3"	4.7	18
4"	2.1	8
⚠ K-Factor is Pre-Programmed		

### Min/Max Flow Rates

Pipe Size (O.D.)	LPM   GPM	LPM   GPM
	0.3m/s min.	10m/s max.
DN08 (¼") SS Only	0.04   0.16	12   3
DN10 (⅜") SS Only	1.0   3.8	50   13
DN15 (½")	3.5   1.0	120   32
DN20 (¾")	5.0   1.5	170   45
DN25 (1")	9.0   2.5	300   79
DN40 (1½")	25.0   6.5	850   225
DN50 (2")	40.0   10.5	1350   357
2½"	60.0   16.0	1850   357
DN80 (3")	90.0   24.0	2800   739
DN100 (4")	125.0   33.0	4350   1149

# Truflo® — TKW Series (Blind) In-Line Paddle Wheel Flow Meter Sensor

## Temperature | Pressure Graphs | Non-Shock

**Note:** The Pressure/Temperature graphs are specifically for the Truflo® Flow Meter Sensors.

During system design the specifications of all components must be considered.

■ = PVC ■ = PP ■ = PVDF

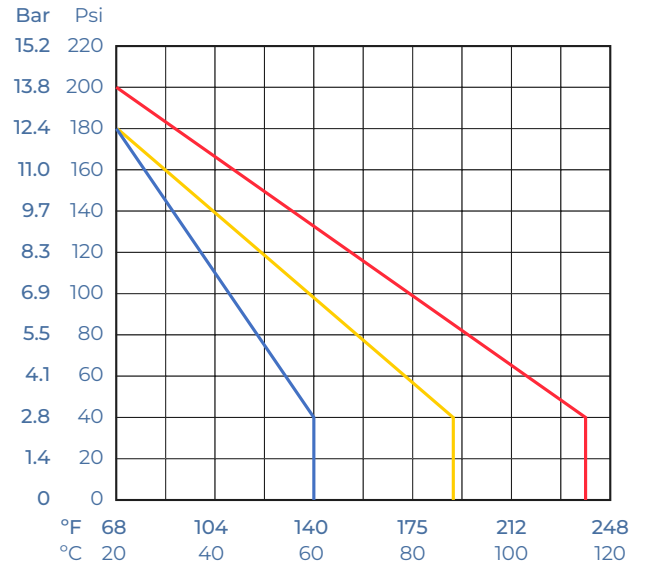

## Model Selection

TKW - 20 - P - T - [ ] - [ ] **NOTE:** Leave blank for standard options

Pipe Size	Material	End Connections	Seals	Optional Output
15: ½"    50: 2"	<b>P:</b> PVC	Sch 80 Soc (Standard on PVC)	FKM (std)	<b>A</b> : 4-20mA
20: ¾"    80: 3"	<b>PP:</b> PP	<b>T:</b> NPT (Standard on PP/PVDF, available on PVC)	<b>E:</b> EPDM	<b>V</b> : 0-5 V
25: 1"    100: 4"	<b>PF:</b> PVDF	<b>F:</b> ANSI 150lb Flange	<b>K:</b> FFKM   Kalrez®	<b>PA:</b> 4-20mA + Pulse
40: 1½"		<b>B:</b> Butt Fusion		

TK3W- 20 - SS - SE - [ ] - [ ] **NOTE:** Leave blank for standard options

Pipe Size	Material	End Connections	Seals	Optional Output
08: ¼"    40 : 1½"	<b>S:</b> SS	<b>T</b> : NPT (Standard)	FKM (std)	<b>A</b> : 4-20mA
10: ⅜"    50 : 2"		<b>SE:</b> Sanitary	<b>E:</b> EPDM	<b>V</b> : 0-5 V
15: ½"    80 : 3"			<b>K:</b> FFKM   Kalrez®	<b>PA:</b> 4-20mA + Pulse
20: ¾"    100: 4"				
25: 1"				

