

**Product Information**

**Temperature**

# Temperature Guard TG50



<b>Output</b>	
Alarm A1-A4	: relay SPDT < 250 V AC < 250 VA < 2 A cos Phi ≥ 0.3 < 300 V DC < 40 W < 2 A
Analog	: 0/4..20 mA burden ≤500 Ω 0/2..10 V burden >500 Ω isolated, automatic output changing (burden dependent)
- Accuracy	: 0.2 %;TK 0.01 %/K
Fault indication	: for broken line or short circuit detection → analog output (programmable) 0 mA, < 3.6 mA or >21.5 mA → Alarm relays min. or max. function programmable
<b>Case</b>	: Polyamide (PA) 6.6 , UL94V-0 TS35 acc. to DIN EN 60715:2001-09
Weight	: approx. 450 g
Connection	: screw terminals 0.14..2.5 mm <sup>2</sup> AWG 26..AWG14
Protection class	: case IP30, terminals IP20 acc. to BGV A3

**Characteristics**

The Temperature-Guard TG50 has inputs for temperature probes RTD (Pt100/Pt1000) and thermocouple J, K, N and S. Simple programming, up to 4 alarm outputs (SPDT) and an available fully isolated free programmable analog output 0/4..20 mA; 0/2..10 V DC offers a lot of solutions for temperature monitoring. Peak value indication for minimum and maximum measured temperature are stored in the background and can be read out from the display at any time.

**Technical data**

<b>Power supply</b>	
Supply voltage	: 230 V AC ±10 % 115 V AC ±10 % 24 V DC ±15 % : < 5 VA
Operating temperature	: -10..+55 °C
CE-conformity	: EN 61326-1:2013 EN 60664-1:2007
<b>Input</b>	
Fault function	: break of wire (RTD Pt100/1000, Thermocouple) and short-circuit (only Pt100/1000)
RTD	: Pt100 (3-wire) -100.0..+600.0 °C Pt1000 (3-wire) -100.0..+300.0 °C : Thermocouple (TC) type J -100.0..+800.0 °C type K -150..+1200 °C type N -150..+1200 °C type S -50..+1600 °C cold junction compensation integrated
Accuracy	: <0.1 %, ±1 Digit
Display	: Graphic LCD-Display, 128 x 64 Pixel, with white back-lite

**Dimensions**

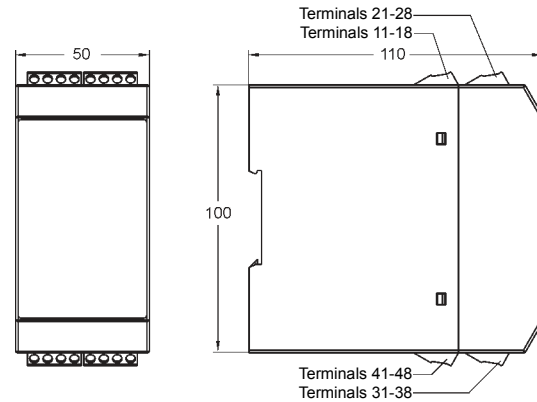

Continue next page.

**Product Information**

**Connection diagram**

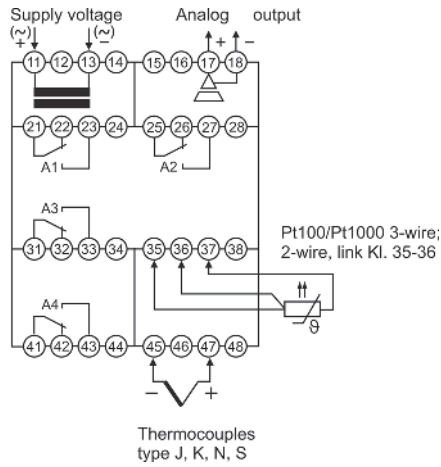

**Ordering code**

1. 2. 3. 4. 5. 6.  
 TG50 -  -  -  -  -  -

- 1. Device type/input**
  - 3 RTD Pt100, 3-wire, -100.0..+600.0 °C
  - RTD Pt1000, 3-wire, -100.0..+300.0 °C
  - Thermocouple
  - J (Fe-CuNi), -100.0..+800.0 °C
  - K (NiCr-Ni), -150..+1200 °C
  - N (NiCrSi-NiSi), -150..+1200 °C
  - S (Pt10Rh-Pt), -50..+1600 °C
- 2. Alarm output A1, A2**
  - 2R 2 relay SPDT
- 3. Alarm output A3, A4**
  - 00 not installed
  - 2R 2 relay SPDT
- 4. Analog output**
  - 00 not installed
  - AO 0/4..20 mA, 0/2..10 V DC, isolated
- 5. Supply voltage**
  - 0 230 V AC, ± 10 % 50-60 Hz
  - 1 115 V AC, ± 10 % 50-60 Hz
  - 5 24 V DC, ± 15 %
- 6. Options**
  - 00 without option