

ProAlert®

The Next Big Thing in Liquid Monitoring

Features

- ✓ High Intensity Red Alarm Light
- ✓ Pulse to Relay Output
- ✓ Super Loud 108dB Audible Alarm
- ✓ Silence Function | Light Remains On
- ✓ Rugged NEMA 4X Industrial Enclosure
- ✓ External Wall Mounting Brackets
- ✓ High Impact Plastic Polycarbonate Shell
- ✓ Includes 6' Power Cord + Watertight Cord
- ✓ Completely Pre-Wired
- ✓ Extra Output Contact to Remote Alarm or PLC

All Plastic
NEMA 4X
Enclosure

Built in
Visual Alarm

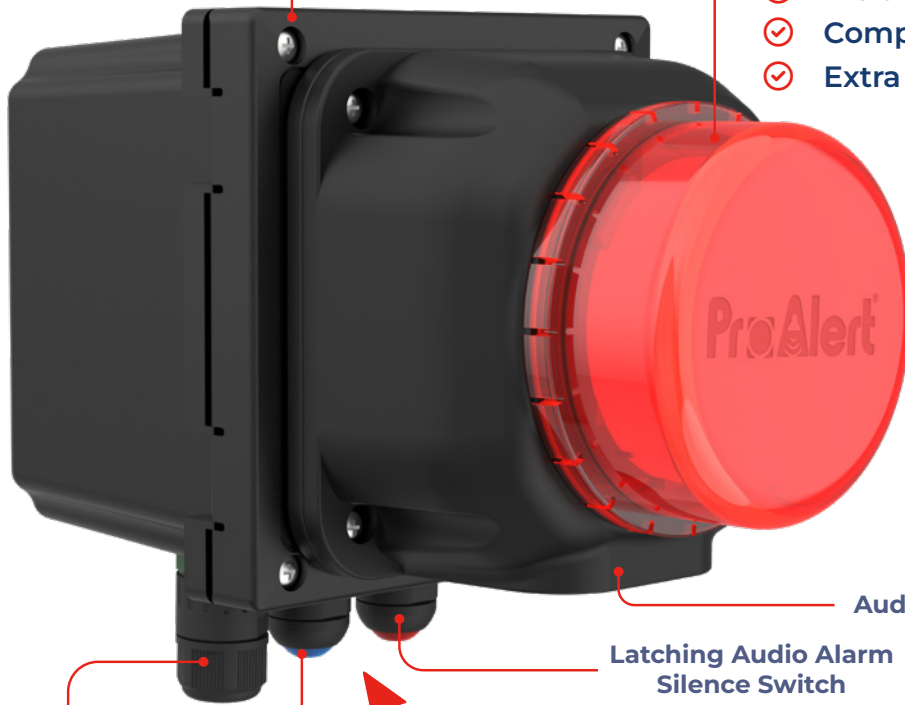

108dB
Audible Alarm

Latching Audio Alarm
Silence Switch

Alarm Test

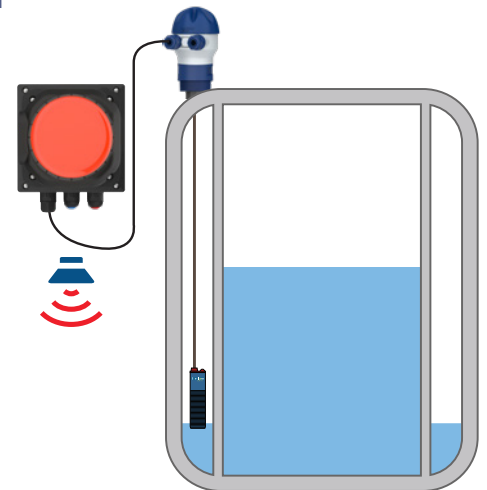
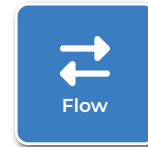

3 Easy Mounting Options

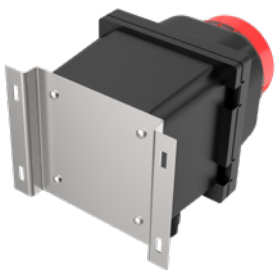

Wall Mount



Panel Mount



Pole/Pipe Mount



Typical Applications

- ✓ High High | Low Level Indication for Tanks | Sumps
- ✓ Bag | Filter Change Out
- ✓ Leak Detection
- ✓ Flow | No Flow Sensors | Pump Protection
- ✓ Upset Condition Notification

Specifications

- ✓ Dimensions | 7" X 5" X 4.5"
- ✓ Enclosure | NEMA 4X
- ✓ Weight | 2.1 lbs.
- ✓ 24VDC
- ✓ 100 - 240VAC (with DC adapter)

Model Selection

ProAlert® PA223

- PNP | NPN | Dry Contact Input
- 10AMP AC | 10AMP DC Relay Output

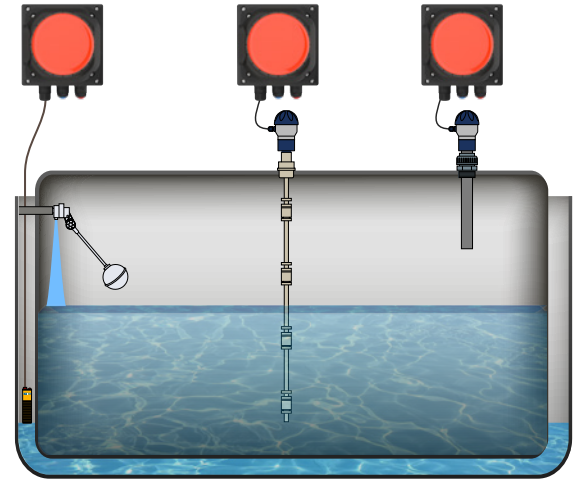

NOTE: The ProAlert® 2 can be used in more than just leak detection applications. It is an excellent high/low level alarm or any other upset condition.

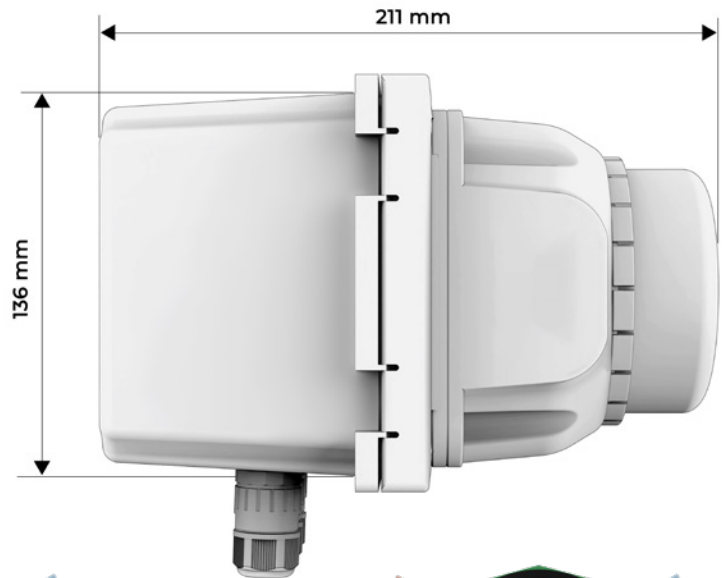

Wiring Diagram

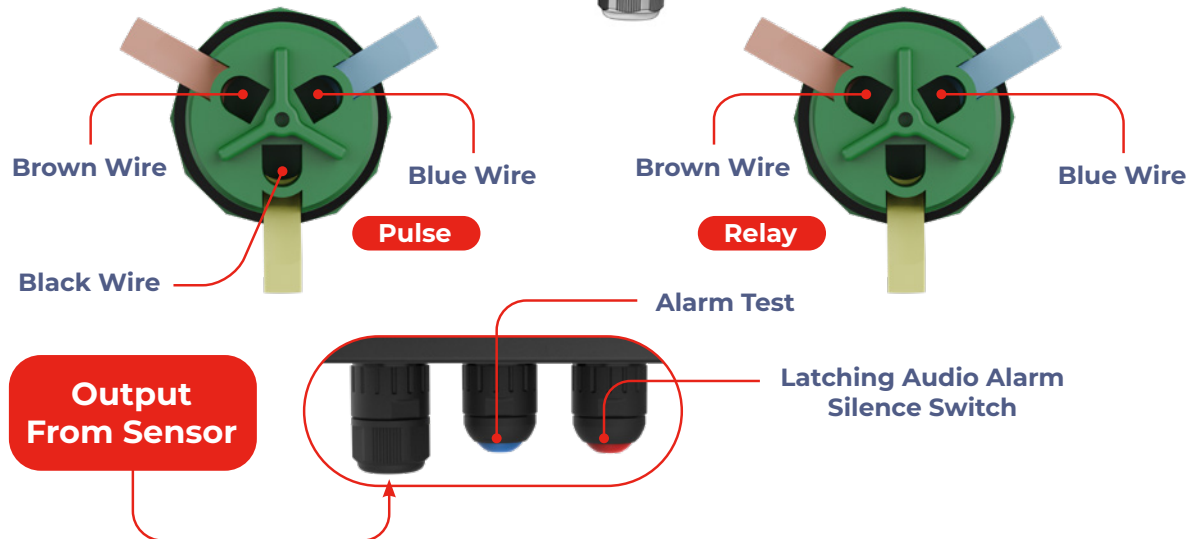
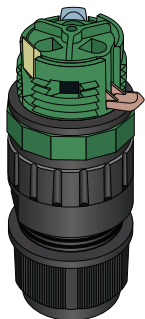

Wiring Diagram

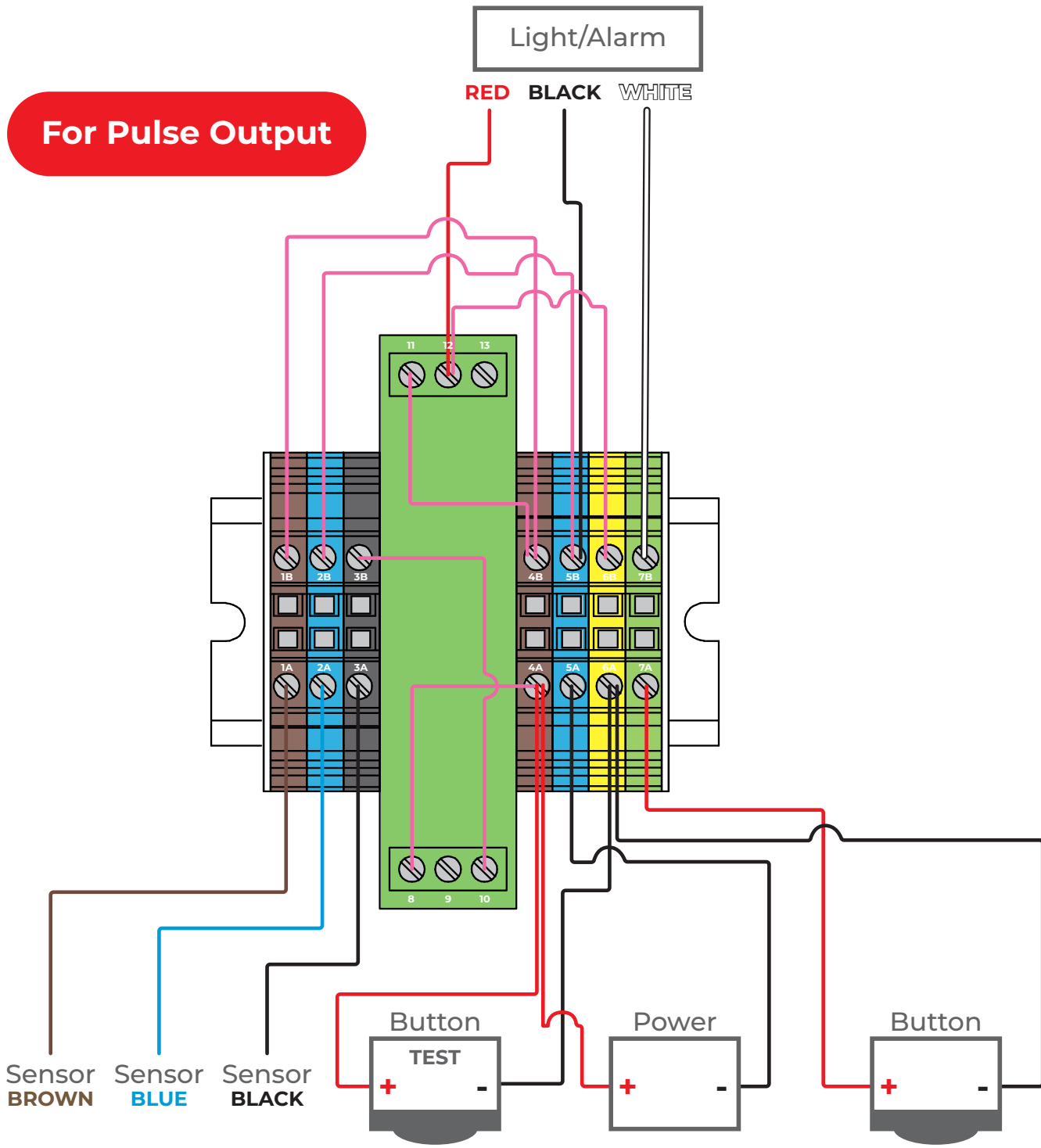

Wiring Diagram

For Leak Detection

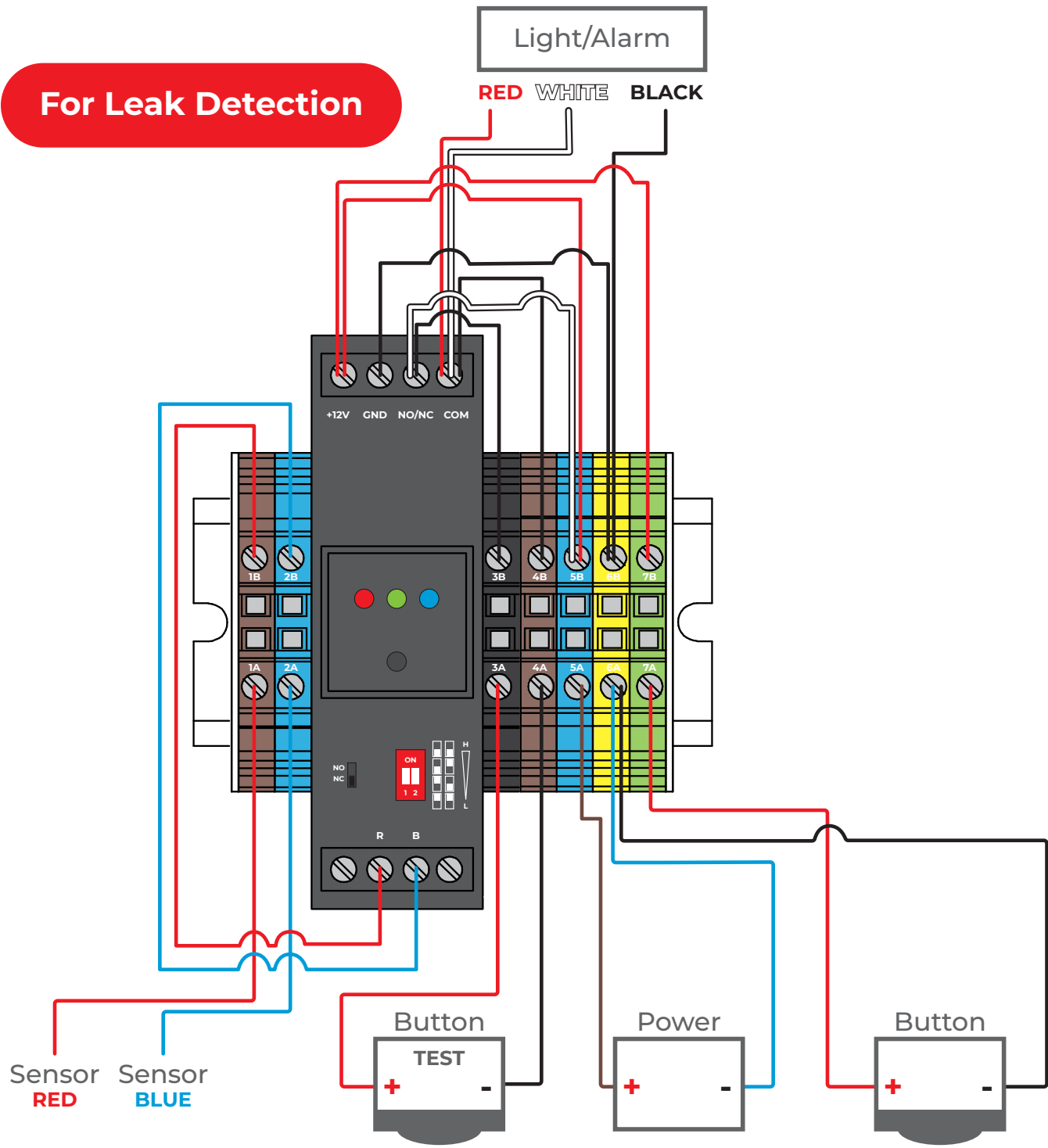

Setup for LDS-YN Leak Detection

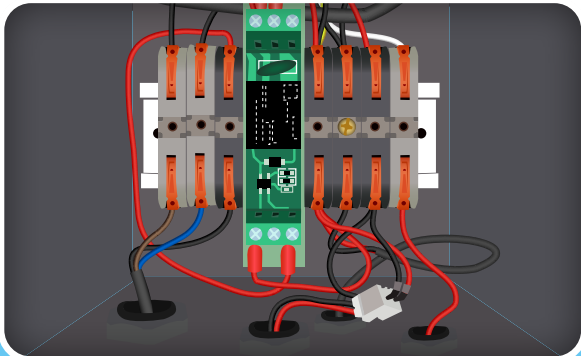

PRE-WIRED
NO INTERNAL WIRING NECESSARY

Inside the Pro-Alert® 2 box, the P2R relay has been prewired to a quick connect which the LDS-YN Leak Sensor will connect to.

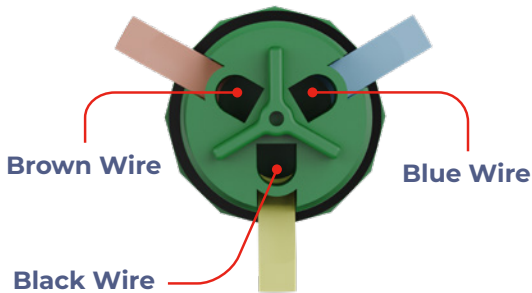

From the LDS-YN Sensor there is a Blue, Black, and Brown wire and they should attach as follows:

- Blue sensor wire will connect to the Blue quick connect terminal.
- Black sensor wire will connect to the Yellow quick connect terminal.
- Brown sensor wire will connect to the Orange quick connect terminal.

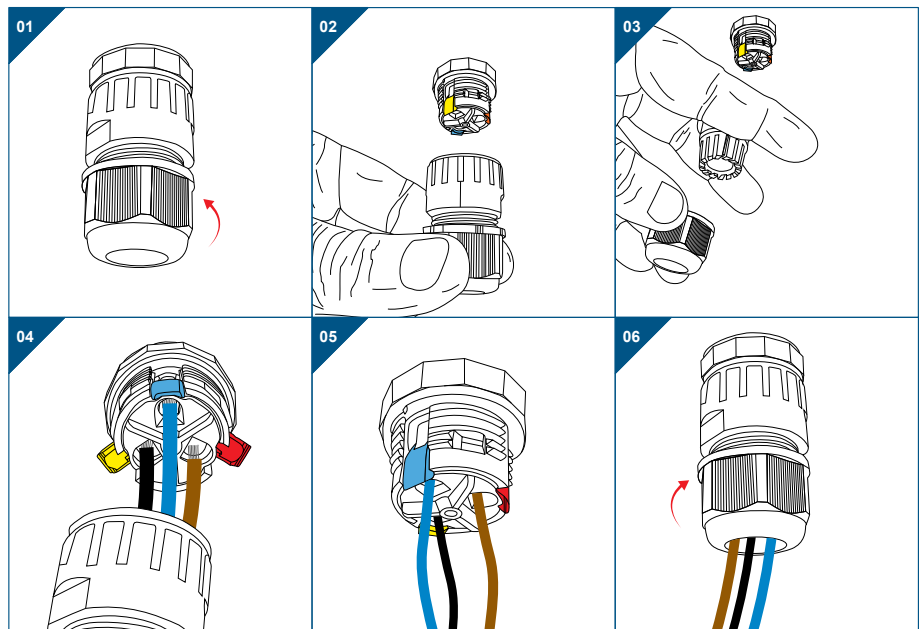

Troubleshooting:

If the sensor is not working properly follow the following steps:

1. If sensor is in constant state of alarm — Place sensor 4" above a cup of water and turn the potentiometer until the system quits alarming. This will calibrate the sensor to detect a liquid 4" from contact.
2. This unit does not provide a 120v output to run to a PLC/Skada system. It only provides a 12-14v output.

