



PRESSURE SWITCHES
PRESSURE DIFFERENCE SWITCHES
VACUUM SWITCHES
From 1.5 mbar to 600 bar

MD Air Relay Switches

CATALOGUE



Certificate No.: FM 72815

Kaustubha Udyog AN ISO9001:2000 COMPANY

S. No. 36/1/1, Sinhgad Road, Vadgaon Khurd,
Near Lokmat Press, Pune 411 041 INDIA
Tel.: +91-(0) 20-24393577 / 24393877
Telefax : +91-(0) 20-25460486 / 24393577
Email : pressure@vsnl.com

Website : <http://www.orion-instruments.com>

MD AIR RELAY SWITCHES



PRESSURE CAPSULE DETAILS

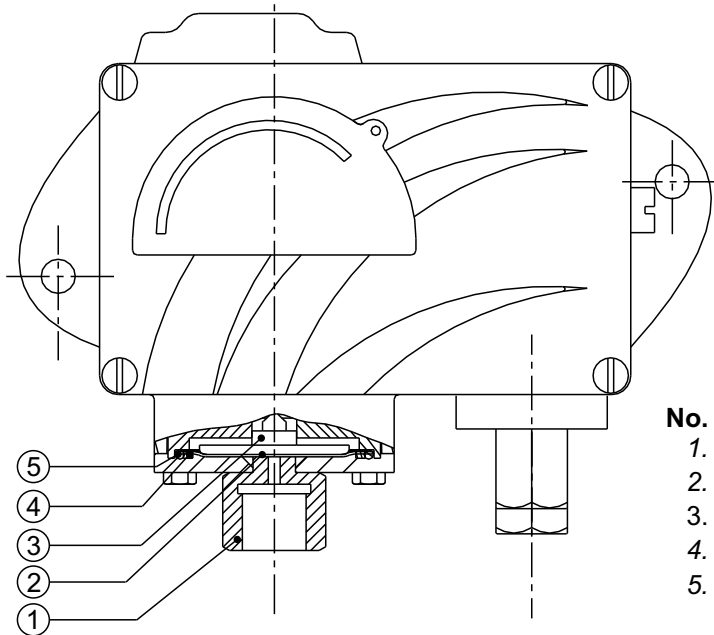

No. Description

1. Pressure Housing (SS316)
2. Diaphragm (Teflon®)
3. Plunger
4. Steel Ring (SS316)
5. O-Ring (Teflon®)

Note : *wetted parts* are mentioned in italics.

INSTALLATION DRAWING

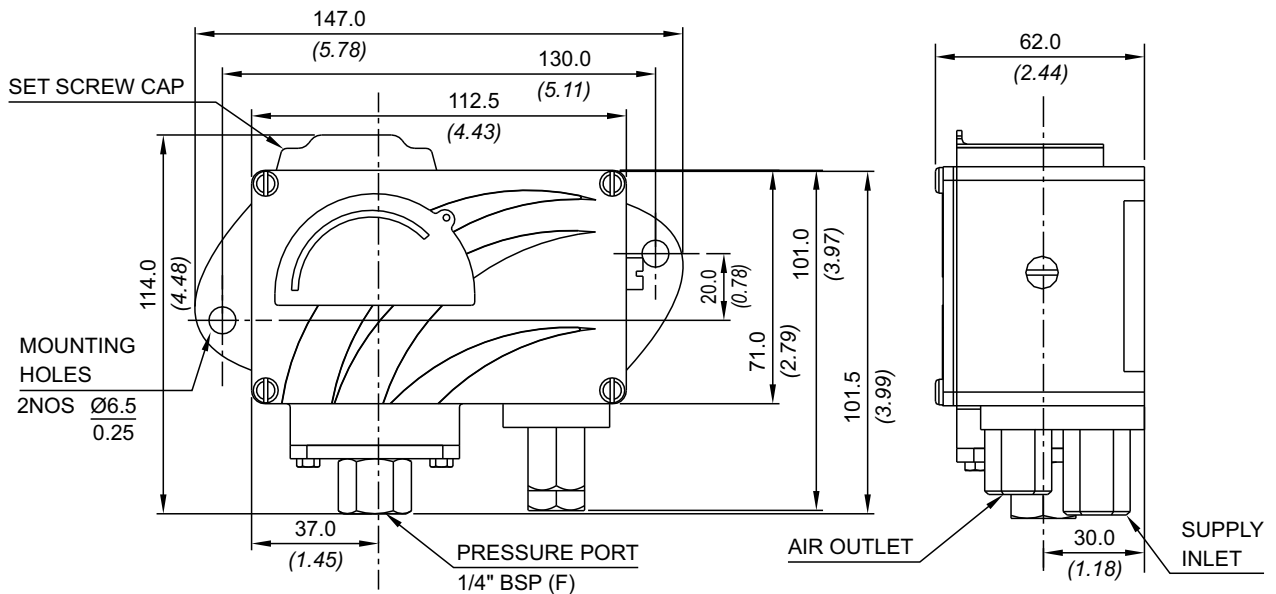

APPROX. DIMENSIONS IN $\frac{\text{mm}}{\text{inches}}$

BULLETIN NO. : KA090121

RANGE SELECTION TABLE

Range Code	Range bar (psi)	†Differential bar (psi)	Maximum Working Pressure bar (psi)
		Approximate Maximum for "A1" microswitch	
LP	0.067 - 0.213 (0.97 - 3.09)	0.02 (0.29)	5 (71.43)
LP5	0.1 - 0.5 (1.45 - 7.25)	0.08 (1.16)	5 (71.43)
H01	0.1 - 1.0 (1.45 - 14.50)	0.10 (1.43)	12 (171.43)
H02	0.1 - 1.5 (1.45 - 21.76)	0.12 (1.74)	12 (171.43)
H03	0.2 - 2.6 (2.90 - 37.71)	0.17 (2.46)	12 (171.43)
H04	0.2 - 3.6 (2.90 - 52.21)	0.20 (2.90)	12 (171.43)
H07	0.5 - 7.0 (7.25 - 101.50)	0.40 (5.72)	12 (171.43)
H10	0.5 - 10.0 (7.14 - 142.86)	0.40 (5.72)	25 (357.14)
H15	1.0 - 15.0 (14.29 - 214.29)	0.80 (11.43)	25 (357.14)
H30	5.0 - 25.0 (71.43 - 357.14)	0.80 (11.43)	35 (500.00)

Pneumatic valve specifications

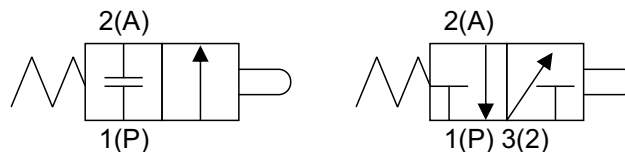

NO valve (P2) = air flows when process pressure < set point
 NC valve (P1) = air flows when process pressure > set point

Supply pressure of air/inert gas = 7 bar max

* Other ranges from 1.5 mbar upto 400 bar too available. Also various pressure capsules for vacuum, pressure difference in a variety of wetted parts too can be supplied. Please contact sales office.

HOW TO ORDER INDUSTRIAL AIR RELAY PRESSURE SWITCHES

Group 1	Group 2	Group 3	Group 4	Group 5	Group 6	Group 7	Group 8
Non standard allocation	Model	Cable Entry Size	Switch Type	Range Code (values in bar)	Microswitch Type	Pressure Port Size	Diaphragm
<input type="checkbox"/> Reserved for non-standard options not covered in catalogue. Will be given by manufacturer, only after agreement of supply details with customer.	MD = Industrial pressure switch with diecast Aluminium enclosure to IP66 as per IS2147	7 = 1/8" BSPF air inlet & outlet pressure supply = 7 bar max	PF1 = pressure switch, fixed differential without scale PF2 = pressure switch, fixed differential with scale PF3 = scale in psi *PA1 = pressure switch, adjustable differential without scale *PA2 = pressure switch, adjustable differential with scale *PA3 = scale in psi	LP = (0.067 - 0.213) LP5 = (0.1 - 0.5) H01 = (0.1 - 1.0) H02 = (0.1 - 1.5) H03 = (0.2 - 2.6) H04 = (0.2 - 3.6) H07 = (0.5 - 7.0) H10 = (0.5 - 10.0) H15 = (1.0 - 15.0) H30 = (5.0 - 25.0)	P1 = NC valve P2 = NO valve	S1 = SS316 pr. Housing with 1/4" BSPF pressure port S2 = SS316 pressure housing with 1/4" NPT(F) pressure port.	0 = Neoprene 1 = Teflon 2 = SS 316L
* Please refer note under Range Selection Table							
<input type="checkbox"/>	MD	7	PF1	H01	P1	S1	0

eg. A high range weatherproof switch with 1/8" BSPF air inlet & outlet parts in aluminium housing as a pressure switch, fixed differential without scale, having 0.1 bar to 1 bar pressure range, NC valve, SS316 pressure housing with 1/4" BSPF port size & neoprene diaphragm shall be specified by

Please specify full model number to avoid ambiguity.