

MD TEMPERATURE SWITCHES

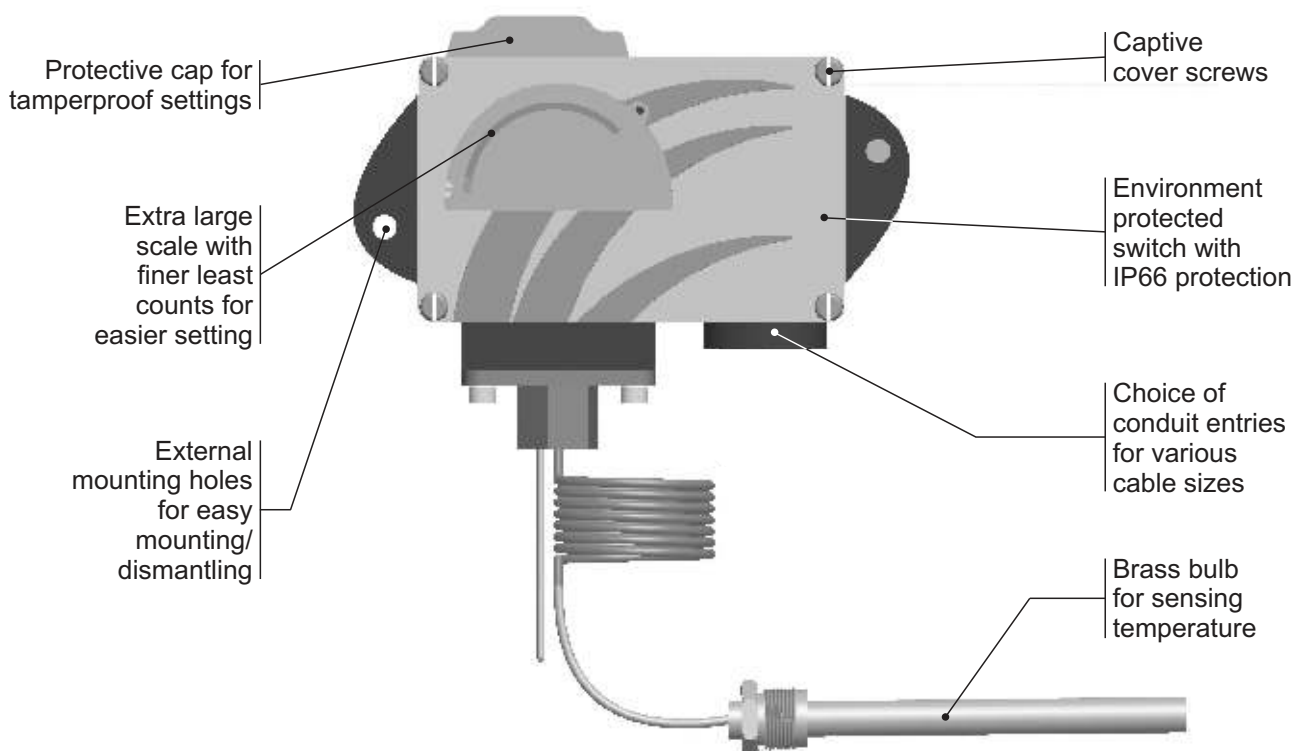
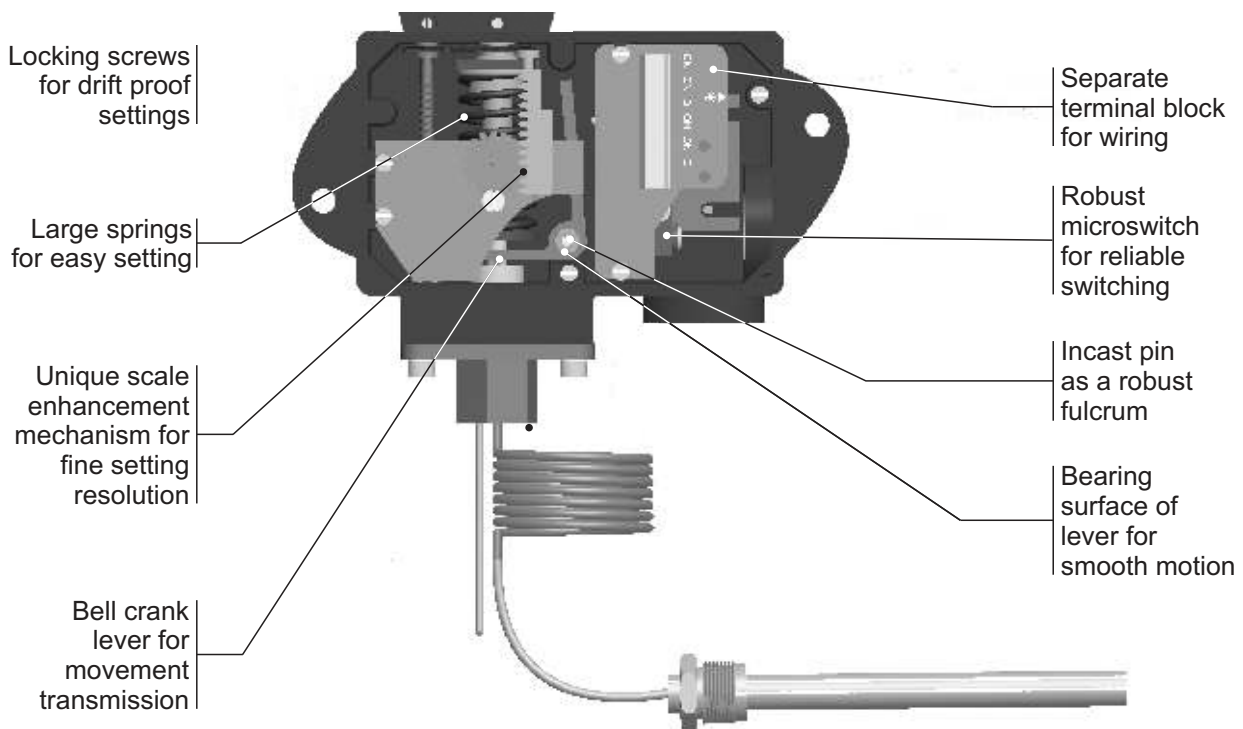

Approximate Weight : 0.950 Kg.

Some Applications : To detect limiting temperature levels in non-hazardous areas.

Electrical Connection :

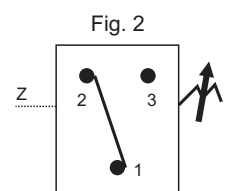



INSTALLATION DRAWING

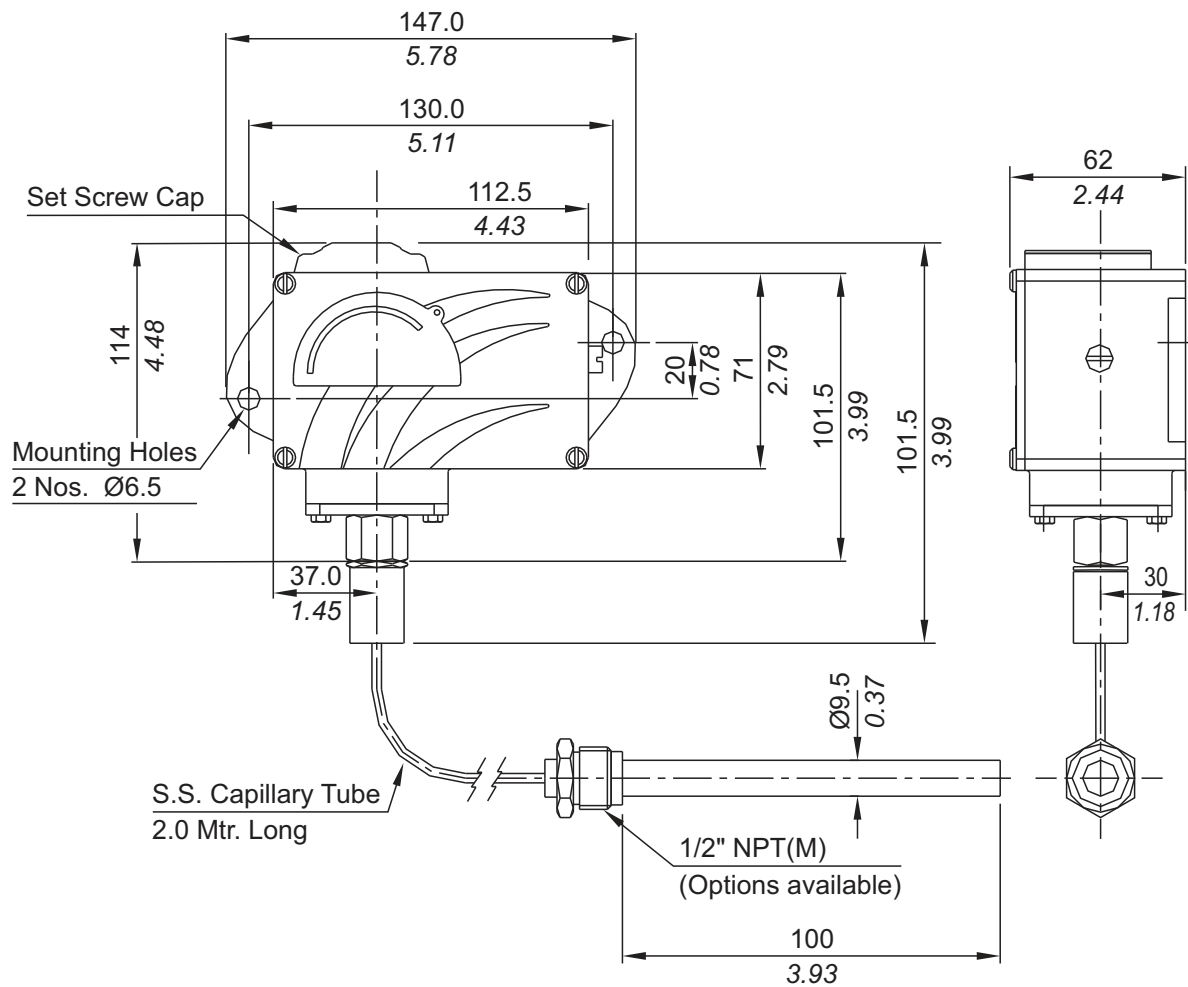

APPROX. DIMENSIONS IN $\frac{\text{mm}}{\text{inches}}$

MD TEMPERATURE SWITCHES

RANGE SELECTION TABLE

Range Code	Range °C (°F)	Differential* °C (°F)	Maximum Working Temperature °C (°F)
		Approximate Maximum for "A1" microswitch	
T1H	25 - 90 (77 - 194)	15 (59)	150 (302)
T2H	70 - 150 (158 - 302)	20 (68)	200 (392)
T3H	120 - 215 (248 - 419)	30 (86)	300 (572)

* Approximate differential at midrange for A1 microswitch. Differentials increase with setpoint. Differentials vary with microswitch combinations. Please consult sales office for details

HOW TO ORDER INDUSTRIAL TEMPERATURE SWITCHES

Group 1	Group 2	Group 3	Group 4	Group 5	Group 6	Group 7	Group 8
Non standard allocation	Gas Group Classification	Cable Entry Size	Switch Type	Range Code (values in °C)	Microswitch Type	Temp. Bulb Material / Size	Capillary Material / Size
<input type="checkbox"/> Reserved for Non-standard Options not covered in Catalogue. Will Be given by Manufacturer, Only after Agreement of Supply details With customer.	MD = Industrial temp. switch with diecast Aluminum Enclosure to IP66	1 = 1/2" NPT threads 2 = 3/4" NPT threads 3 = M20 X 1.5 threads	TF1 = Temperature Switch, fixed differential without scale TF2 = Temperature Switch, fixed differential with scale in °C	T1H = 25 - 90 T2H = 70 - 150 T3H = 120 - 215	A1 = General purpose microswitch rated at 15 A; 250 VAC A7 = 2SPDT switching elements	B1 = Brass / Dia. 9.5 mm, 123 mm length, with 3/8" BSP (M) thermowell connection B2 = Brass / Dia. 9.5 mm, 123 mm length, with 3/8" NPT (M) thermowell connection B3 = Brass / Dia. 9.5 mm, 123 mm length, with 1/2" NPT (M) thermowell connection	2 = SS316 / 2.0 meter

E.g. An Industrial Temperature Switch, with 1/2"NPT cable entry in aluminum housing as 1 SPDT, fixed differential without scale, having 25°C to 90°C temperature range, with 15 Amp. microswitch, with Brass 9.5 mm diameter bulb, having length 123 mm with 3/8"BSP(M), with 2.0 meter SS316 capillary length shall be specified by

Group 1	Group 2	Group 3	Group 4	Group 5	Group 6	Group 7	Group 8
<input type="checkbox"/>	MD	1	TF1	T1H	A1	B1	2

Please specify full model number to avoid ambiguity.