

Product Information

Flow limiter KM-...A

- Male thread



- Metal construction
- Installation location as desired
- No need for auxiliary power

Characteristics

The constant flow is created by two crossways stainless steel spring plates which close or open an annular gap located behind them to a greater or lesser degree, according to the flow value. The controlled value results from the addition of the individual control inputs.

Flow value% of controlled value

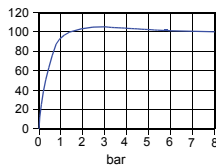

Technical data

Nominal width	DN 32..80		
Process connection	male thread G 3/4 A..G 3 A		
Controlled values	Connection	Controlled value	Control inputs
	G 3/4 A	1.. 30 l/min	1
	G 1 1/2 A	2.. 90 l/min	2..3
	G 2 A	3..120 l/min	3..4
	G 2 1/2 A	5..150 l/min	5
	G 3 A	6..210 l/min	6..7
	Example: The controlled value of 55 l/min is achieved using a limiter with two control inputs of 30 l/min + 25 l/min.		
Control inputs	individual controlled values for the control inputs		
	1 l/min	6 l/min	16 l/min
	2 l/min	8 l/min	20 l/min
	3 l/min	10 l/min	25 l/min
	4 l/min	12 l/min	30 l/min
Tolerance	to 2 l/min: ±15 % of nominal value from 3 l/min: ±10 % of nominal value		
Differential pressure	2..10 bar		
Media temperature	0..200 °C		
Ambient temperature	0..200 °C		

Medium	water	
Materials medium-contact	<i>Brass construction:</i> CW614N nickelled, 1.4310, 1.4301; 1.4121	<i>Stainless steel construction:</i> 1.4571, 1.4310, 1.4301; 1.4121
Weight	see table "Dimensions and weights"	
Installation location	as desired	

Dimensions and weights

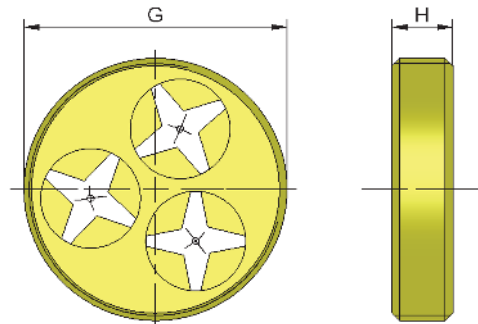

G	Nominal width	Type	H	Control inputs	Weight kg
G 3/4 A	DN 20	KM-020A.	12	1	0.04
G 1 1/2 A	DN 40	KM-040A.	12	2..3	0.11
G 2 A	DN 50	KM-050A.	15	3..4	0.20
G 2 1/2 A	DN 65	KM-065A.	15	5	0.30
G 3 A	DN 80	KM-080A.	15	6..7	0.38

Ordering code

1. 2. 3. 4.
 KM -

1. Nominal width	
020	DN 20 - G 3/4 A
040	DN 40 - G 1 1/2 A
050	DN 50 - G 2 A
065	DN 65 - G 2 1/2 A
080	DN 80 - G 3 A
2. Process connection	
A	male thread
3. Connection material	
M	brass
K	stainless steel
4. Controlled value H₂O	
001	001..030 l/min
	002..090 l/min
	003..120 l/min
	005..150 l/min
	006..210 l/min
210	

Options

- Special values

Ordering information

- Specify direction of flow, medium, and controlled value.
- For viscous media specify viscosity, temperature, and medium (e.g. ISO VG 10) (enquire about controlled value).