

Product Information

Limit value switch

**Limit value switch
GS125**



Colour change of the scale lighting depending on the switch status

- Universal input for unit signals,
- Pt100, thermocouple, potentiometer, switchable via front-side DIP switch
- 1 or 2 relay outputs
- Universal relay connection
- Adjustable min/max contact function
- Actual value output 4 .. 20mA
- 2-colour illuminated scales for limit value adjustment, colour depends on switch status
- With Pt100 sensors, monitoring of sensor break and short-circuit
- Wide-range mains adapter or 24 V DC
- Functional safety up to SIL2
- Housing width 12.5 mm
- Removal coded terminals
- Carrier rail mounting TS35 EN60715
- Safe galvanic isolation between input / output / auxiliary voltage

Technical data

Limit value switches of the series GS125 are used in switch cabinets for process monitoring or for simple process regulation.

Both temperatures and derived variables such as voltage, current and resistance are used as control signals. In the process, 1 or 2 limit values can be monitored.

The universal configurability of the measuring inputs reduces the stock requirement for various applications.

The housing width of only 12.5mm enables space-saving installation in the switch cabinet. The scales for the limit value setting, illuminated red or green depending on the switch status, also enable operating in dark environments.

For assignment of the measuring unit to the scale labelling, 24 transparent adhesive labels are supplied. They can be glued between the adjusting wheels on the front panel.

Measurement inputs

Switchable via DIP switch	
Unit signals	: 0/2..10 V 0/4..20 mA
Potentiometer	: 500 Ω..20 kΩ
Pt100	: -50..50°C 0..50°C 0..100°C 0..150°C 0..200°C 0..300°C 0..500°C
Thermocouple	
FeCuNi, Type J	: 0..250°C 0..500°C
NiCrNi, Type K	: 0..500°C 0..750°C 0..1000°C
PtRhPt, Type S	: 0..1500°C

(Special measurement ranges available on request)

Technical data

Wide-range power supply

Voltage	: 20..125 V DC and 20..250 V AC, (47 - 63Hz), max. 1.5W
---------	--

24 V power supply

Voltage	: 24 V DC +/-15%, max. 1.5W
---------	-----------------------------

Combined data

Rated voltage	: 253 V AC
Test voltage	: 3kV AC between input/relay output/auxiliary voltage
Operating temperature	: -10..60 °C
Storage temperature	: -20..80 °C
Air humidity	: 10..90 % (non-condensing)

Measurement inputs

Voltage	: 0/2..10 V, Ri approx. 20 kΩ
Current	: 0/4..20 mA, Ri approx. 60 Ω
Pt100	: linearised, measurement current approx. 1.6 mA
Thermocouple	: Relays become inactive if there is a sensor break or short-circuit

Thermocouple	: linearised with comparison position compensation
Resistance	: (3-wire), nominal value 500 Ω..20 kΩ Internal reference voltage approx. 1.5 V

Relay outputs

Switching voltage	: < 250 V AC <2 A <500 VA < 125 V DC <0.2 A <25 W < 30 V DC <2 A <60 W
Switching frequency	: max. 5 Hz
Switching hysteresis	: approx. 1%

Functional safety

: SIL2 in accordance with EN61508 (specific data available on request)

Setpoint setting

: Scale precision: 2 %

Actual value output

: 4..20 mA, resistance max. 120 Ω,
No galvanic isolation from the
input signal

Product Information

Input signal	Basic precision-actual value output	Temperature deviation *)
0/2..10V	0.2%	0.004%/K
0/4..20mA	0.2%	0.004%/K
Potentiometer	1%	0.007%/K
Pt100 -50.. 50°C	0.5%	0.03%/K
Pt100 0.. 50°C	0.9%	0.04%/K
Pt100 0..100°C	0.5%	0.03%/K
Pt100 0..150°C	0.2%	0.02%/K
Pt100 0..200°C	0.4%	0.02%/K
Pt100 0..300°C	0.3%	0.01%/K
Pt100 0..500°C	0.2%	0.007%/K
FeCuNi 0..250°C	1.0%	0.04%/K
FeCuNi 0..500°C	0.5%	0.03%/K
NiCrNi 0..500°C	0.5%	0.04%/K
NiCrNi 0..750°C	0.4%	0.03%/K
NiCrNi 0..1000°C	0.3%	0.02%/K
PtRhPt 0..1500°C	1.0%	0.04%/K

*) Measurement deviation depending on the environmental temperature in the switch cabinet (-10..+60°C)

Housing

- Dimensions (WxDxH) : 12.5 x 115 x 108 mm
- Material : PA6.6, light grey, Flammability class V0 (UL94)
- Weight : 120 g
- Protection class : IP20
- Screw terminals : 0,2..2,5 mm², AWG 24..14,
- Push-In-Terminals : 0,5..1,5 mm², AWG 25..16, coded terminals

Dimensions

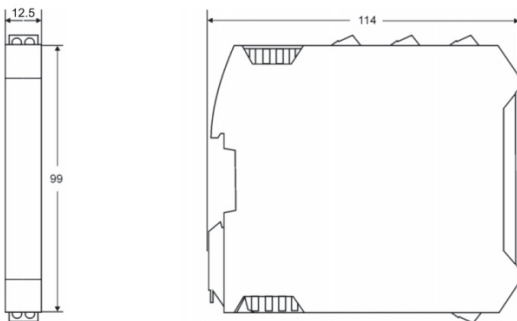

Connection diagram

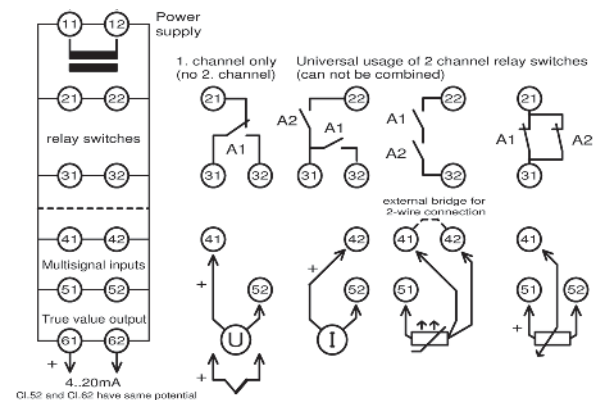

Limit value contacts

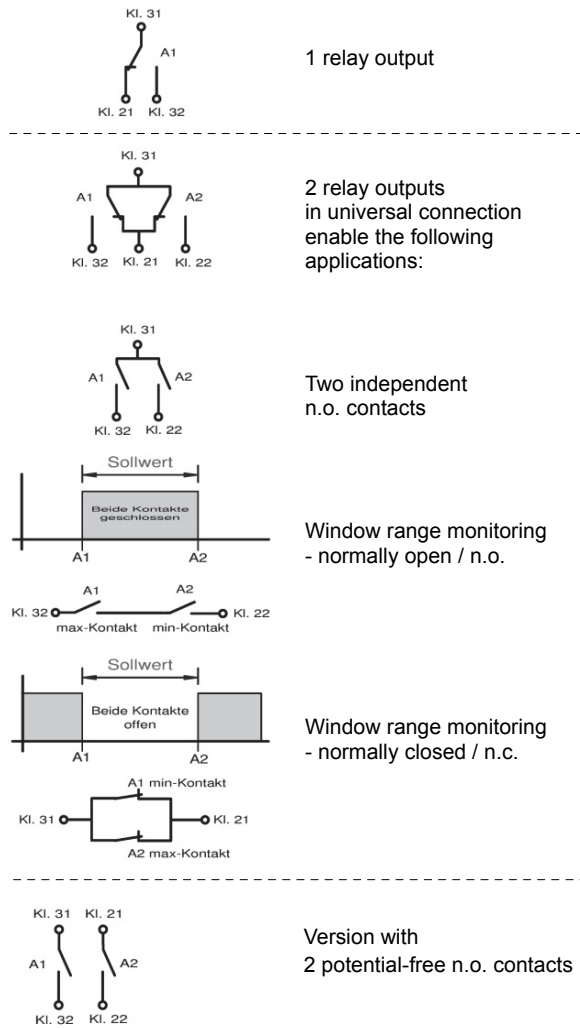

Ordering code

GS 1. 2. 3. 4.

1. Device version	
125L	Power supply 24V DC +/-15%
125LP	Power supply:24V DC +/-15% with carrier rail bus connection *)
125M	Wide-range power supply 20..125 V DC / 20..253V AC
2. Limit value contacts	
1	1 relay (changeover contact)
2	2 relays (universal connection)
3	2 relays (potential-free n.o. contacts)
3. Actual value output	
0	not provided
1	Output 4..20 mA
4. Options	
00	No options
01	Push-in terminals (plug-in)

*) Delivery incl. bus adapter see also separate information sheet Power-Rail