

Flow Switch CRG



- Can be used from nominal width DN 25..200
- Suitable for media with ferritic particles.

Characteristics

The devices function via the principle of a paddle supported by a metal bellows, and the triggering of a micro switch.

Technical data

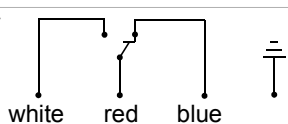
Switch	micro switch	
Nominal width	DN 25..200	
Process connection	male thread R 1"	
Switching range	0.2..165.7 m ³ /h	for details see table "Ranges"
Q_{max.}	up to 240 m ³ /h	
Tolerance	±15 % of full scale value	
Pressure resistance	PN 11 bar	
Medium temperature	-20..+120 °C	
Ambient temperature	-20..+85 °C	
Media	water (oils and aggressive media available on request)	
Wiring	changeover no. 0.374	
Switching voltage	250 V DC	
Switching current	15(8) A	
Protection class	1 - PE connection	
Ingress protection	IP 65	
Electrical connection	cable screw gland M20x1.5	
Materials medium-contact	Brass construction: CW614N, 1.4571, Tombak	Stainless steel construction: 1.4571
Non-medium-contact materials	ABS, PC transparent	
Weight	Brass construction: 0.95 kg	Stainless steel construction: 1.1 kg

Installation location	Standard: horizontal inwards flow; switching unit not recommended underneath; other installation positions are possible; the installation position affects the switching point and range.
------------------------------	---

Ranges

Details in the table correspond to horizontal inwards flow with decreasing flow rate.

● = Standard ○ = Option for reduced switching range

DN	Switching range m ³ /h H ₂ O				Q _{max.} recommended
	Paddle 1	Paddle 1,2*	Paddle 1,2,3*	Paddle 1,2,3,4*	
25	○ 0.20 - 1.0 ● 0.60 - 2.0				3.6
32	○ 0.25 - 1.4 ● 0.80 - 2.8				6.0
40	○ 0.50 - 1.6 ● 1.10 - 3.7				9.0
50	○	0.9 - 3.6 2.2 - 5.7			15.0
65	○	1.2 - 4.9 2.7 - 6.5			24.0
80	○		2.1 - 7.4 4.3 - 10.7		36.0
100	○		4.9 - 17.1 11.4 - 27.7	3.3 - 11.6 6.1 - 17.3	60.0
125	○		9.7 - 34.0 22.9 - 53.3	5.0 - 17.5 9.3 - 25.2	90.0
150	○		13.6 - 47.6 35.9 - 81.7	6.1 - 21.4 12.3 - 30.6	120.0
200	○		25.7 - 90.1 72.6 - 165.7	21.7 - 55.3 38.6 - 90.8	240.0

*must be used together

Dimensions

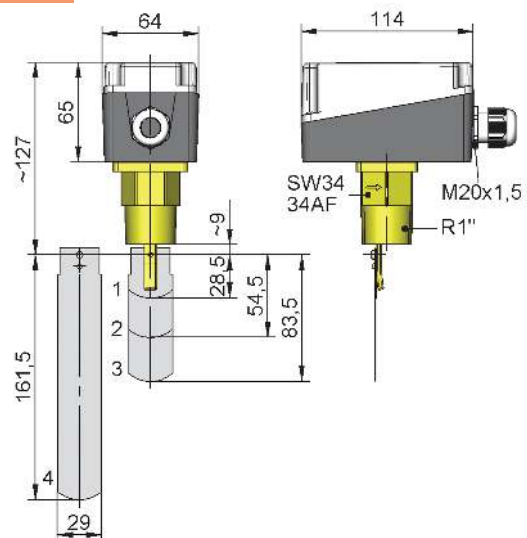

Adapt paddle 1 for DN 25.
From DN 100, adapt paddle 4:
DN 100 Paddle length 92
DN 125 Paddle length 117
DN 150 Paddle length 143

From DN 175 unshortened

Handling and operation

Note

- Attention! Paddle fixing unsecured. For critical conditions (e.g. vibration), fit a bolted fixing.
- Include straight calming section of 10 x DN in inlet and outlet
- If the media are dirty, install a filter.
- It must be ensured that the values given for voltage, current, and power are not exceeded.
- When switched on, a load must be connected in series.
- The electrical details apply to ohmic loads.
Capacitive and inductive loads must be operated using a protective circuit.

Loosen adjustment

Screws, and remove hood; set the desired switching value using the adjustment screw, and refasten the hood.

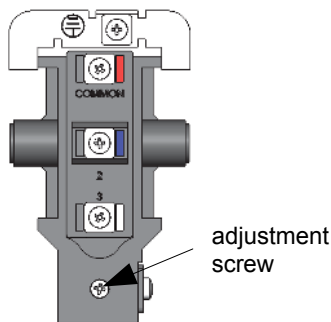

Installation recommendation

Use a tube with standard wall thickness as per DIN 2448

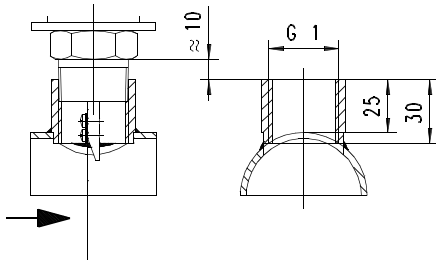

Ordering code

CRG -

1.	2.	3.	4.
025H		S	

○=Option

1. Process connection	
025H	threaded connection DN 25 - R 1 "
2. Connection material	
M	brass
K	stainless steel
3. Cable screw gland	
S	to the side
4. Switching range	
R	<input type="radio"/> reduced

Options

- Switching ranges for oil
- Special values

Ordering information

- Specify direction of flow, medium, and switching range.
- For oils, state viscosity, temperature and designation (e.g. ISO VG 68) (enquire about range).