

Ball Valve Full Port 2-pc Design **WR207**

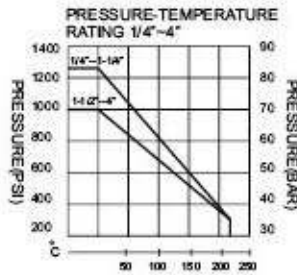

Features:

- Full Port
- Locking Device Handle Upon Request
- Blow-Out Proof Stem
- Balance Hole in Ball Slot
- Spring Ball Seat Design
- Precision Casting
- Design Standard: ASME B16.34
- Testing Standard: API 598/SP-110
- Light Type & DIN3202-M3 Available

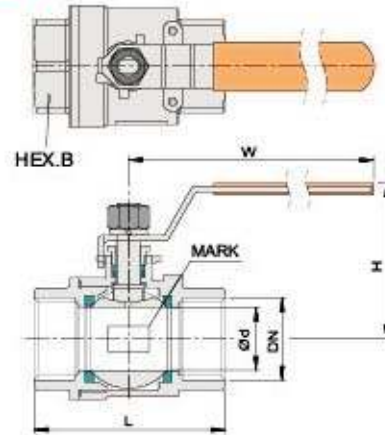

PRESSURE TESTING

STANDARD PRESSURE	1000PSI
SHELL PRESSURE TESTING	10.4Mpa
WATER SEAL TESTING	7.6Mpa
AIR SEAL TESTING	0.4-0.7Mpa

(unit: mm)

3000PSI/PN210
DIMENSION
L* =DIN3202-M3

SIZE	L*	L	Ød	W	H	TORQUE N.M	CV
1/4"	50	55	10.5	100	50	4	2
3/8"	60	55	12	100	50	4	2
1/2"	75	62	15	130	60	5	3.4
3/4"	80	72	20	130	64	7	7.1
1"	90	84	25	165	71	8	12.4
1-1/4"	110	97	32	165	78	15	20.3
1-1/2"	120	104	38	190	86	22	28.5
2"	140	120	49	190	95	25	47.5
2-1/2"	185	150	62	215	130	50	76
3"	205	164	76	250	148	85	108.4
4"	240	200	96	280	180	115	198

DRAWING

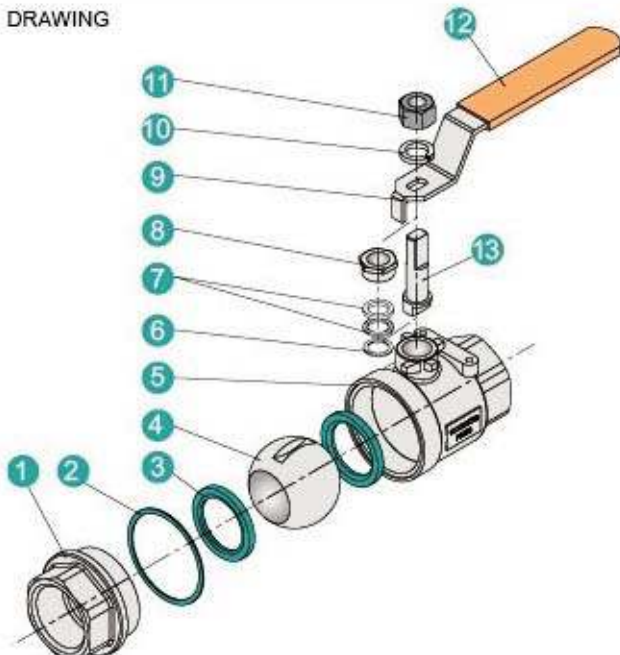

MATERIAL LIST

ITEM	PART NAME	MATERIAL	
1	CAP	CF8M	CF8
2	CAP GASKET	PTFE	
3	BALL SEAT	PTFE	R-PTFE
4	BALL	SUS316	SUS304
5	BODY	CF8M	CF8
6	THRUST WASHER	PTFE	PEEK
7	STEM PACKING	PTFE	
8	STOP NUT	SUS304	
9	HANDLE	SUS304	
10	SPRING WASHER	SUS304	
11	NUT	SUS304	
12	HANDLE COVER	PLASTIC	
13	STEM	SUS316	SUS304