

# SM Series Metering Ball Valves



SERIES: SM  
SIZES: 1/2" to 1"  
ENDS: Socket, Threaded, Butt<sup>1</sup> or ChemFlare™<sup>2</sup>  
SEATS: PTFE  
O-RINGS: EPDM or FPM (Viton®)



### Integral 180° Scale with 5° Increments

- Linear flow control and settable flow rates

Chemline **SM Series** Metering Ball Valve is designed for fine linear flow control of chemicals or clean fluids. The ball is solid with graduated V-groove cut on the outside surface. Precise linear flow control is accomplished through 180° rotation of the handle. With a positioning electric actuator, this becomes an inexpensive control valve. If higher  $C_v$  values (higher flow rates) are required, refer to SP Series Proportional ball valves.

## Features

### Precise Linear Flow Control

- Provided by a special V-groove ball and wide range of handle rotation (0° to 180°)

### High End Ball Valve Features

- Full Blocking design
- Double Stem O-Rings for safety
- PTFE seats with elastomer cushion
  - Automatically compensates for seat wear or expansion
- 230 psi pressure rated (PVC)

### Low Stem Torques

- Due to floating ball design and cushioned PTFE seats

### Bidirectional

- Works with flow in either direction

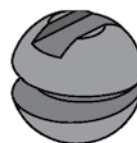

Ball Detail



<sup>1</sup>Butt ends for fusion to Chemline metric PP piping system  
<sup>2</sup>For ChemFlare™ end connectors, consult Chemline

# SM Series Metering Ball Valves



## PARTS

No.	Part	Pcs.	Materials
1	Body	1	PVC, PP
2	Ball	1	PVC, PP
3	Carrier	1	PVC, PP
4	End Connector	2	PVC, PP
5	Union Nut	5	PVC, PP
6	Ball Seat	2	PTFE
7	Handle	1	PVC
8	Stem	1	PVC, PP, PVDF
9	Face O-Ring	1	EPDM, FPM(Viton®)
10	Carrier O-Ring	1	EPDM, FPM(Viton®)
11	Stem O-Ring	2	EPDM, FPM(Viton®)
12	Face O-Ring	1	EPDM, FPM(Viton®)
13	Seat Cushion	2	EPDM, FPM(Viton®)
14	Position Indicator Scale	1	PVC

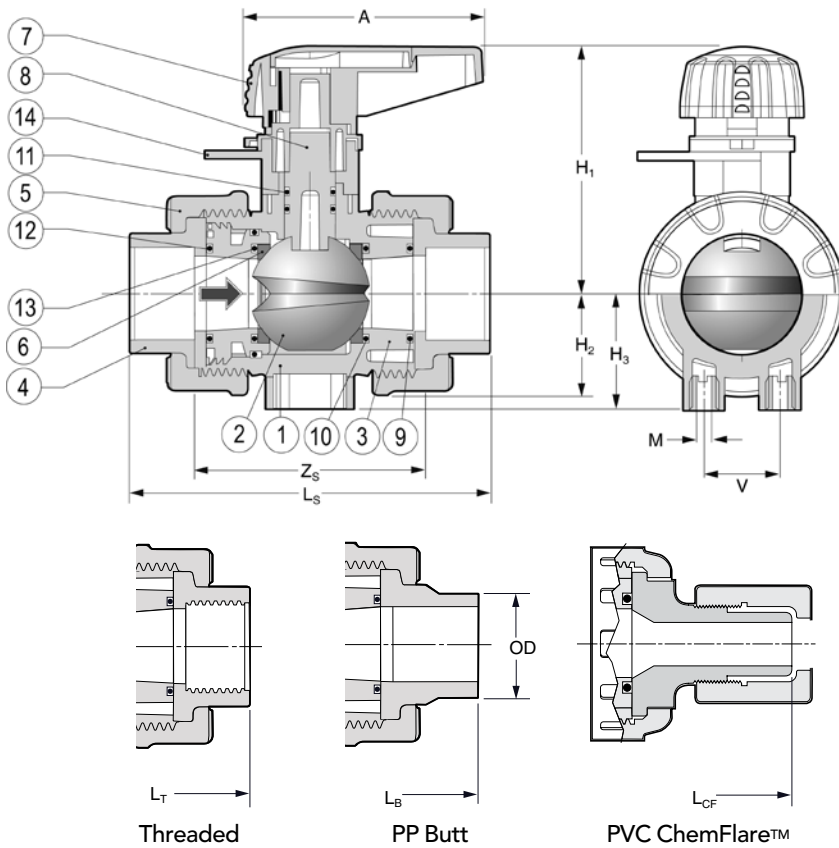

## DIMENSIONS INCHES

Size	A	H <sub>1</sub>	H <sub>3</sub>	H	M	V	PVC					PP				
							Z <sub>s</sub>	L <sub>s</sub>	L <sub>T</sub>	L <sub>Cf</sub> <sup>1</sup>	H <sub>2</sub>	Z <sub>s</sub>	L <sub>s</sub>	L <sub>B</sub>	OD	H <sub>2</sub>
1/2"	2.62	2.48	1.10	2.50	M5	0.98	2.48	3.74	3.75	C.F.	0.99	2.64	3.74	5.16	0.79	1.06
3/4"	3.21	3.03	1.20	2.70	M5	0.98	2.83	4.33	4.36	C.F.	1.16	3.03	4.29	5.65	0.98	1.18
1"	3.21	3.39	1.60	3.00	M6	1.02	3.11	4.84	4.92	C.F.	1.39	3.27	4.69	5.98	1.26	1.57

<sup>1</sup>ChemFlare™ ends are available for reduced tube sizes down to 1/4"

## ELECTRICALLY ACTUATED

The metering ball valve becomes a proportional control valve with the addition of an E Series electric actuator with 4-20 mA positioner

- Thermoplastic housing and mounting bracket
- Manual override
- Position indication
- Plug in electrical connections
- Actuator is prewired inside



**E Series Electric with positioner**

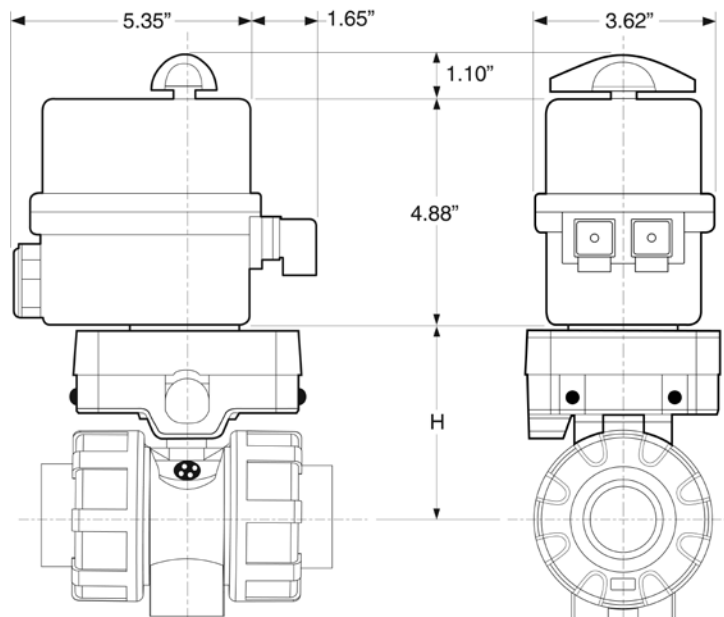

# SM Series Metering Ball Valves



## WORKING PRESSURES PSI

## NET WEIGHTS LBS. Cv VALUES

Size	PVC			PP				PVC	PP	USGPM Flow at 1 psi ΔP
	20°C 68°F	40°C 104°F	60°C 140°F	20°C 68°F	40°C 104°F	60°C 140°F	80°C 176°F			
1/2"	230	130	30	150	100	65	20	0.35	0.29	1.4
3/4"	230	130	30	150	100	65	20	0.60	0.44	1.9
1"	230	130	30	150	100	65	20	0.84	0.64	2.3

Temperature Ranges: PVC 0 to 60°C (32 to 140°F), PP 0 to 95°C (32 to 203°F)

### Cv VALUE vs. VALVE OPENING

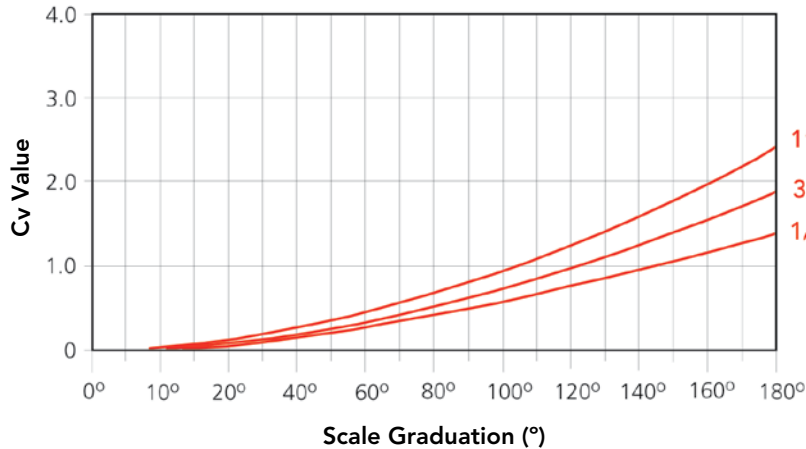

### SAMPLE SPECIFICATION

- All plastic low flow control valves 1/2" to 1" will be Chemline SM Series Metering ball valves
- PVC valves with EPDM or FPM (Viton®) seals will be 230 psi rated, suitable for temperatures up to 60°C/140°F.<sup>1</sup>
- PP valves with EPDM or FKM (Viton®) seals will be 150 psi rated, suitable for temperatures up to 80°C/176°F.<sup>1</sup>
- Ball will molded solid with an outer V-groove for linear flow control over a 180-degree range of handle rotation.
- Valves will have a position indicating scale 0 to 180 degrees with 5-degree increments, to allow fine flow control and settable flow rates.
- Valves will have a threaded-in seat carrier for two-way blocking design and blowout-proof stem with double o-rings for safety.
- Ball seats will be PTFE with elastomer cushions for positive closure and long life.
- Valves will have a base with stainless steel threaded inserts for screws to panel mount or anchor the valve.
- PVC Socket ends shall be Schedule 80 and conform to ASTM D-2467.
- Threaded ends shall be Schedule 80 and conform to ASTM D-2464.
- ChemFlare™ ends will be compatible with Chemline's ChemFlare leak-free tubing system.
- PP Butt fusion ends in will be compatible with Chemline PP metric piping systems.
- Every valve will undergo a factory hydrostatic pressure test to assure quality.

<sup>1</sup> At maximum temperatures, pressure ratings are lower than the maximums stated. Refer to the Chemline data sheet.

### VACUUM RATING

- 29.9 inches mercury

### OPTIONS & ACCESSORIES

- **Reduced Ends**
- **ChemFlare™ Ends**
- **Electric Actuator with Positioner**
  - Operates as a linear control valve

### ORDERING EXAMPLE

<b>Chemline SM Series Metering Ball Valves</b>	<b>SM2</b>	<b>A</b>	<b>010</b>	<b>E</b>	<b>S</b>
Valve Material	<b>A</b> – PVC	<b>B</b> – PP			
Size	<b>005</b> – 1/2"	<b>007</b> – 3/4"	<b>010</b> – 1"		
Seals	<b>E</b> – EPDM	<b>V</b> – FPM (Viton®)			
Ends	<b>S</b> – Socket	<b>T</b> – Threaded	<b>B</b> – Butt <sup>1</sup>	<b>CF</b> – ChemFlare™	

**Example:** SM Series Ball Valve, PVC, 1", EPDM seals, socket ends

<sup>1</sup> PP metric butt fusion ends (1/2" to 2") connect to Chemline PP piping systems

SM Series.DS.06.05.23