

FRP Damper Butterfly Valves



FRP

SERIES: DBF

SIZES: 12" – 96"

MATERIALS: Fibreglass Reinforced Plastic (FRP) Engineered Dampers



The Chemline DBF Series FRP Damper Butterfly is manufactured by Canada's foremost fabricator of engineered FRP gas and liquid handling equipment. They have manufactured FRP dampers for demanding process applications since 1967. This is a quality engineered valve designed for corrosive and/or abrasive gasses in FRP large diameter duct systems.

Features

All FRP

Light Weight

- A 72" Damper Butterfly Valve weighs 950 lbs.

Custom Designed

- Engineered for specific service conditions

High Strength

- Made of high elongation vinyl ester resin for high resistance to impact and thermal shock. Heavy duty design for higher pressure drops.

Abrasion Resistant

- Valves can be designed to provide high abrasion resistance outperforming all other materials of construction

Low Leakage

- Gas leakage of less than 1% can be provided with a temperature range from -40°C to 80°C

Low Stem Torque

- PTFE bearings on both ends of shaft assure low torque and maintenance-free operation

Fire Retardant

- Special Fire Retardant Resin is incorporated in all models

Gear, Electric or Pneumatic Actuated

- Heavy duty manual gear operator or electric actuators are available

Positive Seal Models Available

- Consult Chemline with application details

FRP Damper Butterfly Valves

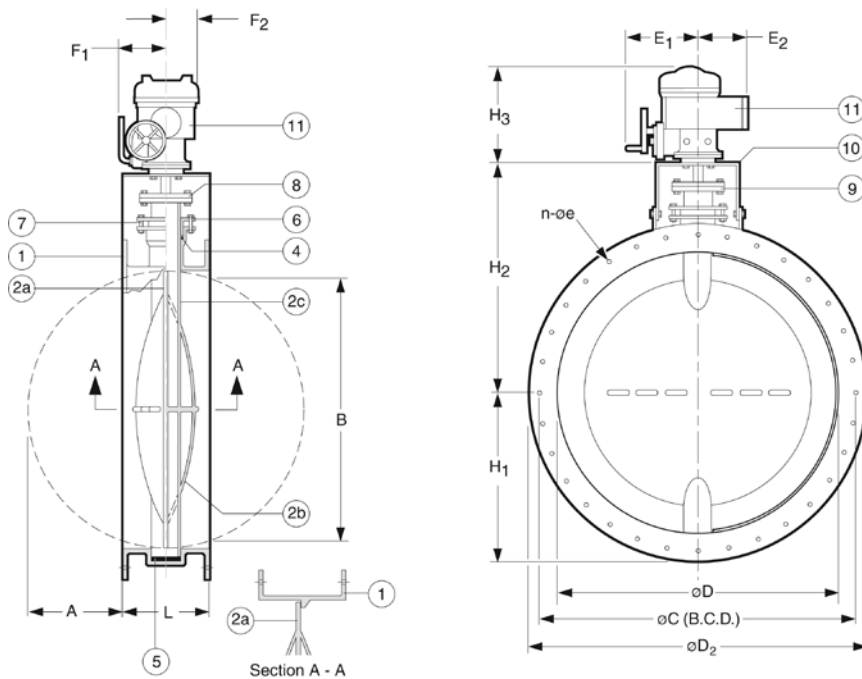

PARTS

No.	Part	Pcs.	Materials
1	Body	1	FRP ¹
2a	Blade	1	FRP ¹
2b	Stiffener	1	FRP ¹
2c	Shaft	1	FRP ¹
4	Shaft Packing	1	PTFE Rope
5	Lower Shaft Bearing	1	PTFE
6	Gland	1	FRP ¹
7	Gland Nuts, Bolts & Washers	4 sets	304 SS
8	Shaft Top Plate	1	304 SS
9	Shaft Plate Nuts, Bolts & Washers	4 sets	FRP ¹ 304 SS
10	Operator Mount	1	304 SS
11	Operator	1	Electric, pneumatic or manual Gear

¹FRP=Fiberglass Reinforced Plastic

DIMENSIONS INCHES

Size	L	A	B	ØD	ØC	n	e	ØD ₂	E	F	H ₁	H ₂	H ₃
24"	12	5.75	20.2	23.5	27	20	0.44	28.4	CF	CF	14.2	23.3	CF
30"	12	8.75	26.9	29.5	33	28	0.44	34.4	CF	CF	17.2	26.3	CF
36"	15	11.75	33.4	35.5	39	32	0.44	40.4	CF	CF	20.2	29.3	CF
42"	15	14.75	39.7	41.5	45	36	0.44	46.4	CF	CF	23.2	32.3	CF
48"	15	17.75	46.0	47.5	52	44	0.44	54.4	CF	CF	27.2	35.3	CF
54"	18	20.75	52.1	53.5	58	44	0.56	60.4	CF	CF	30.2	38.3	CF
60"	18	23.75	58.3	59.5	64	52	0.56	66.4	CF	CF	33.2	41.3	CF
66"	18	26.75	64.4	65.5	70	52	0.56	72.4	CF	CF	36.2	44.3	CF
72"	18	29.75	70.5	71.5	76	52	0.56	78.4	CF	CF	39.2	47.3	CF

For all other sizes consult Chemline.

SAMPLE SPECIFICATION

- Material of construction shall be Derakane 510N resin or equal for the corrosion liner and Derakane 510N c/w antimony trioxide or equal for the structural portion of the damper (Class 1 fire rating as per ASTM E-84 tunnel test).
- Corrosion liner shall be made using one (1) layer of nexus veil followed by three (3) layers of 1.5 oz. chopped strand mat.
- All major components will be manufactured of FRP (i.e. body, shaft, blade and blade stiffener).
- FRP mating flanges will be an integral part of the damper with sizing as per CGSB 41-GP-22 latest addition.
- Two (2) 180 degree heavy FRP seal rings will be incorporated into body to fit against the FRP blade.
- Drive end of shaft will have a PTFE shaft seal.
- Bottom end of shaft shall be supported on a PTFE bearing surface.
- Shaft shall be designed to provide bending stiffness and torsional stiffness required for the applicable service.
- Reinforce FRP damper blade with dished surfaces will to ensure proper stiffness and strength.
- FRP shaft shall be machined at both ends to provide proper sealing and smooth bearing surfaces.
- Actuator support and coupling adapter shall be manufactured from 304 stainless steel to provide ample strength and corrosion resistance.

ELECTRIC ACTUATORS

- NEMA 4 epoxy coated enclosure
- Declutchable manual gear override
- Visual Position Indicator
- Torque plus Travel Limit Switches
- Motor Overload Protection
- Many options available

PNEUMATIC ACTUATORS

- Corrosion Resistant epoxy and Rilsan coated aluminum
- Spring Return or Double Acting
- Optional solenoid valves, positioners, limit switch boxes, hand wheel manual override, etc.

POSITIVE SEAL VERSIONS – Consult Chemline