

Exner Characterized Control Valves



SERIES: EK – Pneumatic
EE – Electric

SIZES: 1/2" to 4"

TYPE: Single Seat Globe or Needle

ENDS: Flanged¹

SHAFT SEAL: PTFE Bellows

BODY SEAL: EPDM, FKM (Viton®) or FEP

Fibreglass Reinforced Polyester Actuator for external corrosion resistance and light weight

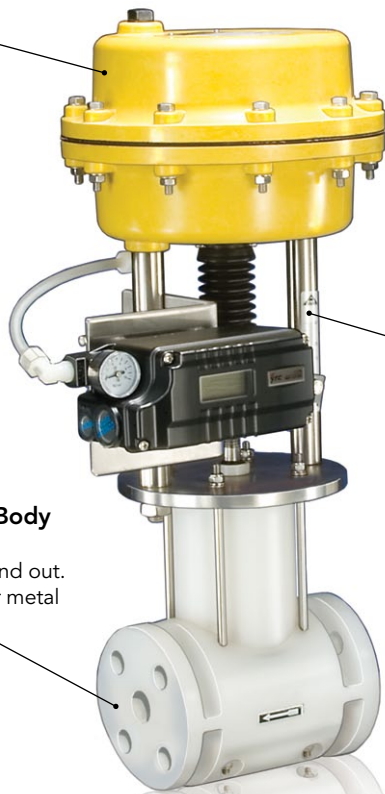

Visual Position Indicator

Monobloc Thermoplastic Body
Resists aggressive chemicals inside and out. Strong enough for metal piping systems.

EK Series with PVDF body and optional positioner

The Chemline **E Series** Exner Characterized Control Valves provide extremely precise flow control of aggressive fluids. Valves flow characteristics (C_v vs. lift) follow theoretical linear or equal percentage curves through the entire range of stem travel. This is accomplished with precision made replaceable seats and plugs in a wide variety of C_v values.

The PTFE bellows shaft seal provides almost frictionless stem movement and provides over 10 years of maintenance-free operation on aggressive chemical services².

Features

Precise and Sensitive Control

- Predictable and repeatable control of corrosive fluids. These valves respond smoothly and quickly to small changes in signal. Deadband and hysteresis is negligible.

High Rangeability

- Valve characteristics (flow rate vs. stem lift) follows the theoretical curves through the entire range of opening including extreme ends of travel

Class IV Leakage

- Rate is 0.01% of rated capacity according to ANSI B16.104-1976

Large Choice of C_v Values

- 18 standard C_v 's from 0.11 to 105.00
- Smaller C_v 's down to 0.003 are available

Field Interchangeable Seats and Plugs

- Valve C_v may be changed later if flow conditions change
- Special materials are available

Abrasion Resistant

- Have outperformed metal valves on aggressive and crystallizing services

With Optional Local Control



EE Series Electrically Actuated

¹ANSI flat face flanges are standard, DIN flat face flanges EN 1092-1A are available on request
²Service history references are available on request

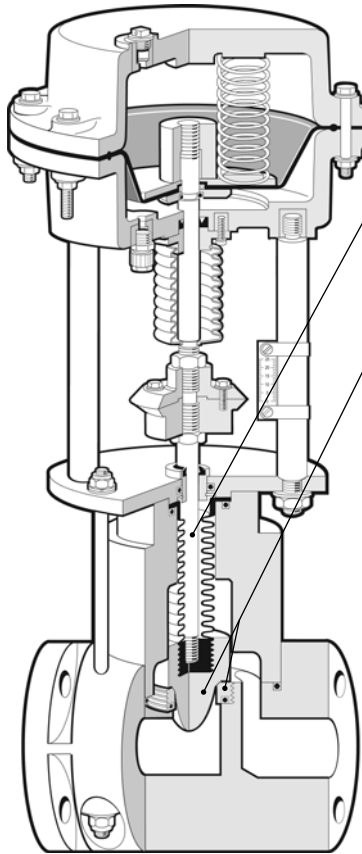

PTFE Bellows Stem Seal:

- Almost frictionless stem travel for sensitive operation and precise control
- High Chemical Resistance – PTFE resists aggressive services
- Long Cycling Life – Low maintenance – Safety

Characterized Plug and Seat Set

- A wide choice of seat/plugs with standard C_v values are available characterized either equal percentage or linear
- Globe Plugs are available for any special specified C_v value from 0.11 to 105.00
- Seats and plugs are easily replaceable in the field. If operating conditions change, the valve C_v may be changed.



High Pressure Valve

- Solid PVDF body with stainless steel armouring for working pressures up to 16 bar (230 psi)
- PTFE stem packing, Titanium stem



Lime Slurry Valve

- Special abrasion resistant design for lime slurry service
- Stainless steel body
- PTFE stem packing
- CrNi coated trim

Chlorine Valve

- Solid PVDF body, PTFE Stem Packing
- Hastelloy bellows and shaft
- Snifter connection to monitor stem seal

Needle Valve

- Needles are available linear characteristic in Hastelloy, Titanium, Tantalum or 316 SS with small C_v 's 0.003 to 0.2

Flow Characteristic Curves & Valve Sizing

VALVE SIZING GUIDELINES

In general, for optimum system control, the valve should operate between 30% and 70% of stem stroke (valve opening).

Linear

For **linear characteristics** the required C_v 's should be between 30% and 70% of valve C_v

Equal Percentage

For **equal percentage characteristic** the required C_v 's should be between 5% and 25% of valve C_v

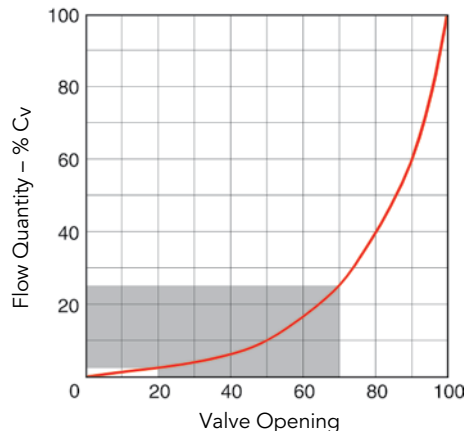
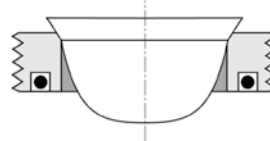
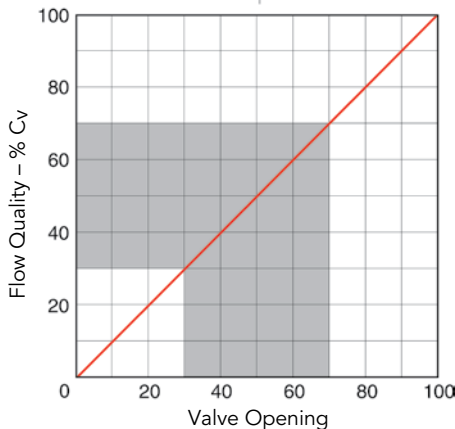
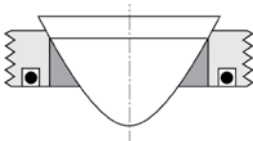

Exner Characterized Control Valves

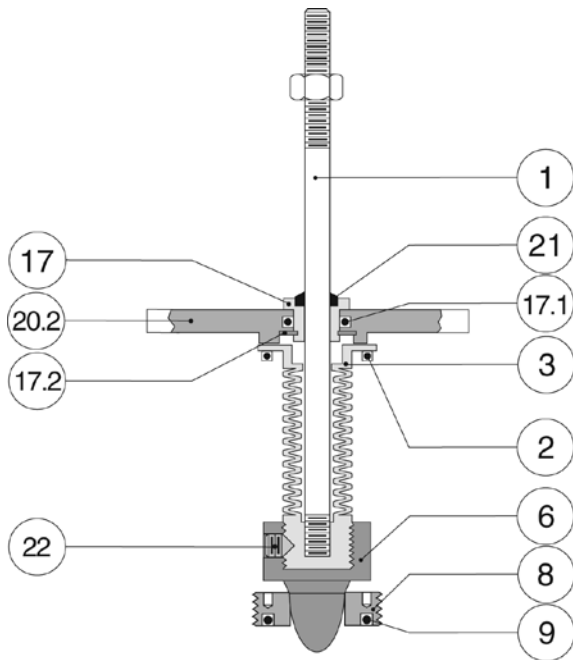

SEAL & TRIM PARTS

No.	Part	Pcs.	Materials
1	Stem	1	SS 316Ti, Titanium, Hastelloy
2	Bellows O-Ring	1	EPDM, FKM (Viton®), FEP
3	Bellows	1	PTFE
6	Plug	1	PVC, PP, PVDF, PTFE
8	Seat	1	PVC, PP, PVDF, PTFE
9	Seat O-Ring	1	EPDM, FKM (Viton®), FEP
17	Guide Bushing	1	CPVC
17.1	O-Ring	1	EPDM, FKM (Viton®)
17.2	Lock Ring	1	A2 SS
20.2	Mounting Flange	1	SS 316Ti
21	Wiper Ring	1	FKM (Viton®)
22	Set Screw ¹	1	PVDF

¹Only on valve sizes 1-1/4" to 4"

C_v VALUES & MAXIMUM SHUTOFF PRESSURES – PVC/PP Valves

VACUUM RESISTANCE • 29.9 inches mercury

Valve Size	Maximum Shut-off Pressure at 20°C																			
	90 psi															60 psi				
	C _v =	0.12	0.23	0.46	0.70	1.20	1.75	2.60	4.00	6.10	9.50	10.5	16.0	25.0	40.0	46.0	64.0	81.0	93.0	
1/2"	✓	✓	✓	✓	✓	✓	✓													
3/4"	✓	✓	✓	✓	✓	✓	✓	✓	✓											
1"	✓	✓	✓	✓	✓	✓	✓	✓	✓											
1-1/4"					✓	✓	✓	✓	✓	✓	✓									
1-1/2"									✓	✓	✓	✓								
2"										✓	✓	✓	✓							
2-1/2"											✓	✓	✓	✓	✓					
3"												✓	✓	✓	✓	✓				
4"														✓	✓	✓	✓	✓	✓	✓

C_v VALUES & MAXIMUM SHUTOFF PRESSURES – PVDF/PTFE Valves

Valve Size	Maximum Shut-off Pressure at 20°C																			
	150 psi												120 psi	90 psi	60 psi					
	C _v =	0.12	0.23	0.46	0.70	1.20	1.75	2.60	4.00	6.10	10.5	14.0	18.0	29.0	40.0	52.0	70.0	93.0	105.0	
1/2"	✓	✓	✓	✓	✓	✓	✓													
3/4"	✓	✓	✓	✓	✓	✓	✓	✓	✓											
1"	✓	✓	✓	✓	✓	✓	✓	✓	✓	✓										
1-1/4"					✓	✓	✓	✓	✓	✓	✓	✓								
1-1/2"									✓	✓	✓	✓	✓							
2"										✓	✓	✓	✓	✓						
2-1/2"											✓	✓	✓	✓	✓					
3"												✓	✓	✓	✓	✓				
4"														✓	✓	✓	✓	✓	✓	✓

WORKING PRESSURES PSI, for all valve sizes

PVC			PP				PVDF					PTFE				
40°C	50°C	60°C	50°C	60°C	70°C	80°C	40°C	60°C	80°C	100°C	120°C	130°C	40°C	60°C	80°C	140°C
104°F	122°F	140°F	122°F	140°F	158°F	176°F	104°F	140°F	176°F	212°F	248°F	266°F	104°F	140°F	176°F	284°F
90	50	15	90	70	50	30	150	115	90	70	45	30	150	150	115	30

Temperature Ranges: PVC 0 to 60°C (32 to 140°F), CPVC 0 to 95°C (32 to 203°F), PP -20 to 80°C (-4 to 176°F), PVDF -40 to 130°C (-40 to 266°F).



**EK Series Pneumatically Actuated
PVC or PP Moulded Body**

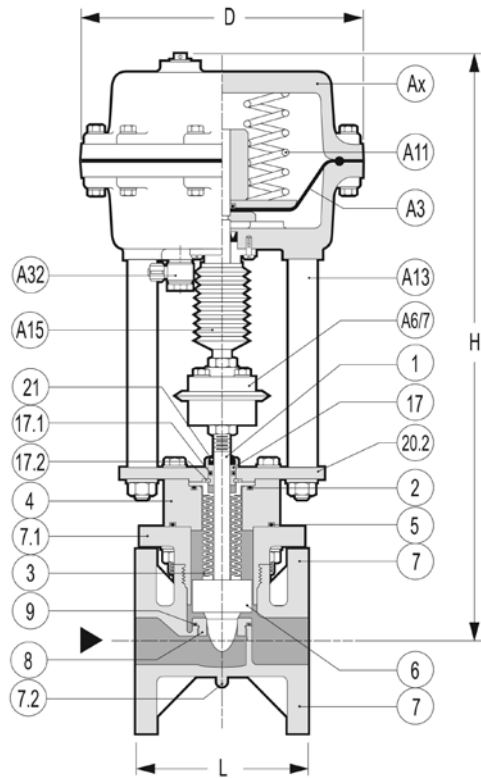

PARTS

▲ Recommended Spare Parts

No.	Part	Pcs.	Materials
1	Stem	1	316 SS
2▲	Bellows O-Ring	1	EPDM, FKM (Viton®)
3▲	Bellows	1	PTFE
4	Upper Bonnet	1	PVC, PP
5▲	Body O-Ring	1	EPDM, FKM (Viton®)
6▲	Plug	1	PVC, PP
7	Body	1	PVC, PP
7.1	Lower Bonnet	1	PVC, PP
8▲	Seat	1	PVC, PP
9▲	Seat O-Ring	1	EPDM, FKM (Viton®)
17	Guide Bushing	1	CPVC
17.1▲	O-Ring	1	EPDM, FKM (Viton®)
17.2	Lock Ring	1	Stainless Steel
20.2	Mounting Flange	1	316 SS
21▲	Wiper Ring	1	FKM (Viton®)
Ax	Pneumatic Actuator	1	FRP
A3	Diaphragm	1	Reinforced EPDM
A6	Coupling	1	316 SS
A7	Coupling	1	316 SS
A11	Spring	6	Coated Steel
A13	Mounting Post	2	316 SS
A15	Upper Shaft Bellows	1	CSM
A32	Air Connection	1	1/4" FNPT

DIMENSIONS INCHES

WEIGHTS LBS.

Size	D	H	L	Stroke	Bolt Holes			Actuator Type	PVC	PP
					No.	Dia.	BCD			
1/2"	8.7	17.4	3.3	0.6	4	5/8"	2.38	K220	18.7	17.0
3/4"	8.7	17.5	3.7	0.6	4	5/8"	2.75	K220	18.9	17.2
1"	8.7	17.5	4.3	1.0	4	5/8"	3.12	K220	19.9	18.1
1-1/4"	8.7	17.8	5.3	1.0	4	5/8"	3.50	K220	21.3	19.4
1-1/2"	8.7	17.6	7.5	1.0	4	5/8"	3.88	K220	22.6	20.5
2"	8.7	17.7	7.9	1.0	4	3/4"	4.75	K220	24.0	21.8
2-1/2"	13.0	23.3	8.7	1.6	4	3/4"	5.49	K330	47.3	43.0
3"	13.0	23.3	9.4	1.6	4	3/4"	6.00	K330	67.9	61.7
4"	13.0	23.4	11.4	1.6	8	3/4"	7.50	K330	82.5	75.0

EK Series valves – FRP Actuator – 90 psi maximum supply air.

The actuator will close the valve tightly against higher line pressure drops, up to 90 psi depending on the Cv.

ACCESSORIES FOR EK SERIES

Positioners – YT Series linear valve positioners are usually used on all EK Series pneumatically actuated control valves. They control actuator-valve stem position as a linear function of input signal, usually electronic (most often 4–20 mA) or sometimes pneumatic (3–15 psi). Valves with C_v 9.5 (PVC & PP valves) and C_v 10.5 (PVDF & PTFE valves) or lower may be operated with the 3–15 psi signal directly without a positioner, but the linearity is compromised. The standard units have epoxy coated aluminum enclosures but are available in 316 stainless steel. All available models are attractively priced:

- **YT1200R 3–15 psi Pneumatic** – a conventional all-mechanical positioner
- **YT1300R 4–20 mA Electro-Pneumatic** – an electronic positioner designed for vibration resistance, better control and easy calibration

- **YT2300 4–20 mA Smart** – a fully digital positioner with intelligent functions like auto calibration, PID control, also theoretical and user defined characterized output. Options include alarms (switch or relay output), 4–20 mA transmitter for position feedback and HART digital communication protocol.

Air Filter/Regulator – Chemline includes an air filter/regulator with all positioners to prevent orifices from clogging due to debris and to protect from corrosion or fouling due to excess oil or condensed water in the air supply. The F/R-A is a one-piece air filter/regulator and pressure gauge with a GRP plastic body, polycarbonate filter bowl and polyethylene filter element. The filter bowl has a manual drain valve.

EK Series Pneumatic PVDF & PTFE

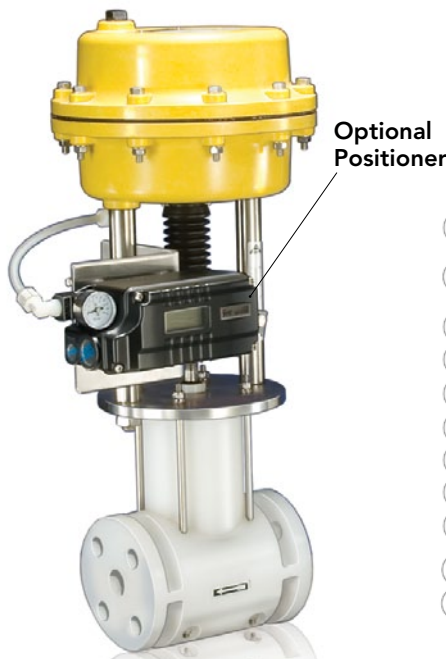

EK Series Pneumatically Actuated PVDF or PTFE Machined Body

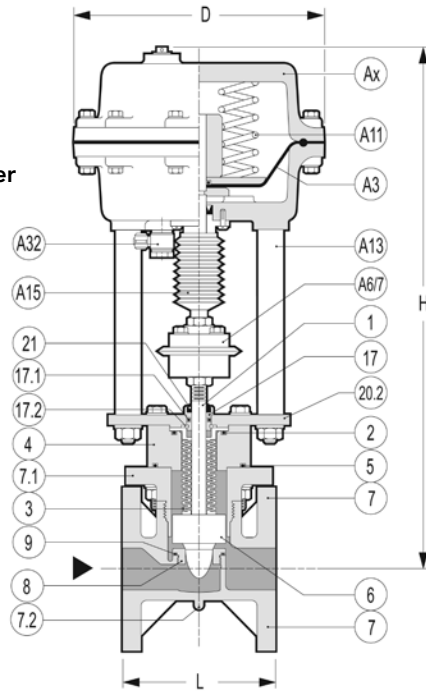

PARTS

▲ Recommended Spare Parts

No.	Part	Pcs.	Materials
1	Stem	1	316 SS
2▲	Bellows O-Ring	1	FKM (Viton®), FEP
3▲	Bellows	1	PTFE
4	Bonnet	1	PVDF, PTFE
5▲	Body O-Ring	1	FKM (Viton®), FEP
6▲	Plug	1	PVDF, PTFE
7	Body	1	PVDF, PTFE
8▲	Valve Seat	1	PVDF, PTFE
9▲	Seat O-Ring	1	FKM (Viton®), FEP
17	Guide Bushing	1	CPVC
17.1▲	O-Ring	1	FKM (Viton®), FEP
17.2	Lock Ring	1	Stainless Steel
20.2	Mounting Flange	1	316 SS
21▲	Wiper Ring	1	FKM (Viton®)
Ax	Pneumatic Actuator	1	FRP
A3	Diaphragm	1	Reinforced EPDM
A6	Coupling	1	316 SS
A7	Coupling	1	316 SS
A11	Spring	6	Coated Steel
A13	Mounting Post	2	316 SS
A15	Upper Shaft Bellows	1	CSM
A32	Air Connection	1	1/4" FNPT

DIMENSIONS INCHES

WEIGHTS LBS.

Size	D ₂	H	L	Stroke	Bolt Holes				Actuator Type	PVDF	PTFE
					No.	BCD	PVDF ¹	PTFE ¹			
1/2"	8.7	18.4	5.1	0.6	4	2.38	5/8"	1/2"UNC	K220	18.7	26.5
3/4"	8.7	18.7	5.9	0.6	4	2.75	5/8"	1/2"UNC	K220	20.9	30.9
1"	8.7	18.7	6.3	1.0	4	3.12	5/8"	1/2"UNC	K220	23.1	36.4
1-1/4"	8.7	18.8	7.1	1.0	4	3.50	5/8"	1/2"UNC	K220	26.5	41.9
1-1/2"	8.7	19.0	7.9	1.0	4	3.88	5/8"	1/2"UNC	K220	32.0	50.7
2"	8.7	19.3	9.1	1.0	4	4.75	3/4"	5/8"UNC	K220	35.3	55.1
2-1/2"	13.0	24.6	11.4	1.6	4	5.49	3/4"	5/8"UNC	K330	68.3	79.4
3"	13.0	44.9	12.2	1.6	4	6.00	3/4"	5/8"UNC	K330	79.4	99.2
4"	13.0	24.9	13.8	1.6	8	7.50	3/4"	5/8"UNC	K330	88.2	121.3

EK Series valves – FRP Actuator – 90 psi maximum supply air.

The actuator will close the valve tightly against higher line pressure drops, up to 150 psi depending on the Cv.

Note: 5" and 6" valves consult Chemline. ¹PVDF are bolt holes, PTFE are threaded UNC inserts.

ORDERING EXAMPLE – EK SERIES PNEUMATICALLY ACTUATED

Chemline Characterized Control Valves		EK	K	005	NC	V	F
Actuator Type	EK – Pneumatic						
Body	A – PVC	B – PP	K – PVDF	P – PTFE			
Size	005 – 1/2"	007 – 3/4"	010 – 1"	012 – 1-1/4"	015 – 1-1/2"		
	020 – 2"	025 – 2-1/2"	030 – 3"	040 – 4"			
Control Function	NC – Normally Closed		NO – Normally Open				
Body Seal	E – EPDM ²		V – FKM (Viton®)		P – FEP		
Ends	F – Flanged ³						

Also specify: Characteristic (linear or equal percentage) and Cv Value (from chart on page 3).

Example: Chemline EK Series Pneumatically Actuated Characterized Control Valve, PVDF, 1/2", Normally Closed, with Viton® body seal, flanged, Cv Value = 0.23 Linear. ²EPDM available with PVC or PP bodies only. ³ANSI flat face flanges are standard, DIN flat face flanges EN 1092-1A are available upon request.



**EE Series Electrically Actuated
PVC or PP Moulded Body**

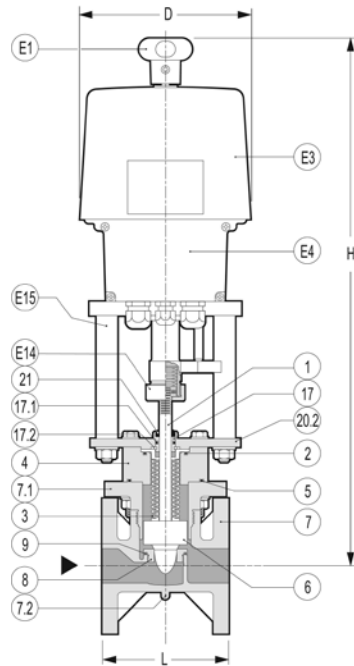

- **Power Supply:** 115 VAC/50/60Hz
- **Enclosure Rating:** NEMA 4X, IP 65 with temperature and load protection
- **Current Draw:** 0.23 amps.
- **Adjustable Opening/Closing Times:** 1/2" to 2" valves: 32 to 62 sec.;
2-1/2" to 4" valves: 55 to 111 sec.
- **Optional Voltages:** 230 VAC/50/60Hz, 24 VDC or 24VAC
- **4-20mA Retransmit:** For valve position feedback, 2 or 3-wire technology
- **Duty Cycle:** 50%
- **Maximum Power Consumption:** 30 VA
- **Control Input:** 0-10 V or 0-20mA

PARTS

▲ Recommended Spare Parts

No.	Part	Pcs.	Materials
1	Stem	1	316 SS
2▲	Bellows O-Ring	1	EPDM, FKM (Viton®)
3▲	Bellows	1	PTFE
4	Bonnet	1	PVC, PP
5▲	Body O-Ring	1	EPDM, FKM (Viton®)
6▲	Plug	1	PVC, PP
7	Body	1	PVC, PP
7.1	Flange	1	PVC, PP
8▲	Valve Seat	1	PVC, PP
9▲	Seat O-Ring	1	EPDM, FKM (Viton®)
11-14	Body Bolts & Nuts	4	316 SS
17	Guide Bushing	1	CPVC
17.1▲	O-Ring	1	EPDM, FKM (Viton®)
17.2	Lock Ring	1	Stainless Steel
20.2	Mounting Flange	1	316 SS
21▲	Wiper Ring	1	FKM (Viton®)
E1	Position Indicator	1	Polycarbonate
E3	Actuator Cover	1	Polycarbonate
E4	Terminal Box	1	Polycarbonate
E14	Coupling	1	Stainless Steel
E15	Mounting Post	2	Stainless Steel

DIMENSIONS INCHES

WEIGHTS LBS.

Size	D	H	L	Stroke	Bolt Holes			Actuator Type	PVC	PP
					No.	Dia.	BCD			
1/2"	7.0	21.6	3.3	0.6	4	5/8"	2.38	PSL202	17.6	15.9
3/4"	7.0	21.7	3.7	0.6	4	5/8"	2.75	PSL202	17.8	16.1
1"	7.0	21.7	4.3	1.0	4	5/8"	3.12	PSL202	18.8	17.0
1-1/4"	7.0	21.9	5.3	1.0	4	5/8"	3.50	PSL202	20.2	18.3
1-1/2"	7.0	21.8	7.5	1.0	4	5/8"	3.88	PSL202	21.5	19.4
2"	7.0	21.8	7.9	1.0	4	3/4"	4.75	PSL202	22.9	20.7
2-1/2"	7.0	24.4	8.7	1.6	4	3/4"	5.49	PSL204	21.9	17.6
3"	7.0	24.4	9.4	1.6	4	3/4"	6.00	PSL204	42.5	36.4
4"	7.0	24.7	11.4	1.6	8	3/4"	7.50	PSL204	57.1	49.6

ACCESSORIES FOR EE SERIES

Limit Switches – Two extra mechanical SPDT limit switches for valve position feedback

Output Relay – A normally open contact for remote indication of Manual/Auto mode or fault indication

Heater/Thermostat – Prevents condensation forming inside the actuator enclosure and is recommended for outdoor or high humidity areas

Fail-Safe Battery Pack – A Ni-Cd battery pack with controlled charger. In case of loss of power the valve will be powered to a chosen safety position, open or closed.

Local Control Box – The lockable model PSC.2 box permits manual operation of the valve. The backlit LCD display allows the user to do most of the actuator settings, displays the valve's actual position and status (manual or auto) or shows diagnostic messages. It is normally attached to the actuator but can be mounted remotely.

PSCS Communication Software – This software allows a high degree of functionality through a user friendly Windows interface. Many functions beyond the setting, monitoring and diagnostic functions of the Control Box are available including custom output characterization, alarm monitoring, etc. Values can be graphically displayed and analyzed on the computer monitor. Preventative maintenance is possible resulting in better safety and management of the process.

Fieldbus/Blue Tooth Interface – Electronic modules are available for all common field bus interfaces or Bluetooth protocol. Actuator status, settings and diagnostics read-outs are possible at distances up to 10 meters (33 feet).

Process Controller – This is an integral PI(D) process controller located inside the actuator

EE Series Electric PVDF & PTFE



EE Series Electrically Actuated PVDF or PTFE Machined Body

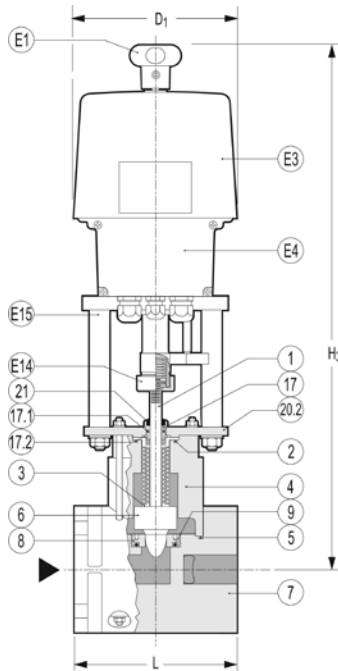

- **Power Supply:** 115 VAC/50/60Hz
- **Enclosure Rating:** NEMA 4X, IP 65 with temperature and load protection
- **Current Draw:** 0.23 amps.
- **Adjustable Opening/Closing Times:** 1/2" to 2" valves: 32 to 62 sec.; 2-1/2" to 4" valves: 55 to 111 sec.
- **Optional Voltages:** 230 VAC/50/60Hz, 24 VDC or 24VAC
- **4-20mA Retransmit:** For valve position feedback, 2 or 3-wire technology
- **Duty Cycle:** 50%
- **Maximum Power Consumption:** 30 VA
- **Control Input:** 0-10 V or 0-20mA

PARTS

▲ Recommended Spare Parts

No.	Part	Pcs.	Materials
1	Stem	1	316 SS
2▲	Bellows O-Ring	1	FKM (Viton®), FEP
3▲	Bellows	1	PTFE
4	Bonnet	1	PVDF, PTFE
5▲	Body O-Ring	1	FKM (Viton®), FEP
6▲	Plug	1	PVDF, PTFE
7	Body	1	PVDF, PTFE
8▲	Valve Seat	1	PVDF, PTFE
9▲	Seat O-Ring	1	FKM (Viton®), FEP
11-14	Body Bolts & Nuts	4	316 SS
17	Guide Bushing	1	CPVC
17.1▲	O-Ring	1	FKM (Viton®), FEP
17.2	Lock Ring	1	Stainless Steel
20.2	Mounting Flange	1	316 SS
21▲	Wiper Ring	1	FKM (Viton®)
E1	Position Indicator	1	Polycarbonate
E3	Actuator Cover	1	Polycarbonate
E4	Terminal Box	1	Polycarbonate
E14	Coupling	1	Stainless Steel
E15	Mounting Pillar	2	Stainless Steel

DIMENSIONS INCHES

WEIGHTS LBS.

Size	D	H	L	Stroke	Bolt Holes			Actuator Type	PVDF	PTFE	
					No.	BCD	PVDF ¹				
1/2"	7.0	22.5	5.1	0.6	4	2.38	5/8"	1/2"UNC	PSL 202	17.6	25.4
3/4"	7.0	22.8	5.9	0.6	4	2.75	5/8"	1/2"UNC	PSL 202	19.8	29.8
1"	7.0	22.8	6.3	1.0	4	3.12	5/8"	1/2"UNC	PSL 202	22.0	35.3
1-1/4"	7.0	22.9	7.1	1.0	4	3.50	5/8"	1/2"UNC	PSL 202	25.4	40.8
1-1/2"	7.0	23.1	7.9	1.0	4	3.88	5/8"	1/2"UNC	PSL 202	30.9	49.6
2"	7.0	23.4	9.1	1.0	4	4.75	3/4"	5/8"UNC	PSL 202	34.2	54.0
2-1/2"	7.0	25.9	11.4	1.6	4	5.49	3/4"	5/8"UNC	PSL 204	43.0	54.0
3"	7.0	26.2	12.2	1.6	4	6.00	3/4"	5/8"UNC	PSL 204	54.0	73.9
4"	7.0	26.2	13.8	1.6	8	7.50	3/4"	5/8"UNC	PSL 204	62.8	95.9

¹PVDF are bolt holes, PTFE are threaded UNC inserts.

ORDERING EXAMPLE – EE SERIES ELECTRICALLY ACTUATED

Chemline Exner Control Valves		EE	1	K	005	V	F
Actuator Type	EE – Electric						
Voltage	1 – 115 VAC/60Hz 2 – 230 VAC/50Hz 4 – 24 VDC 6 – 24 VAC/60Hz						
Body	A – PVC B – PP K – PVDF P – PTFE						
Size	005 – 1/2" 007 – 3/4" 010 – 1" 012 – 1-1/4" 015 – 1-1/2" 020 – 2" 025 – 2-1/2" 030 – 3" 040 – 4"						
Body Seal	E – EPDM ² V – FKM (Viton®) P – FEP						
Ends	F – Flanged ³						

Also specify: Characteristic (linear or equal percentage) and Cv Value (from chart on page 3).

Example: Chemline EE Series Electrically Actuated Exner Control Valve, 115VAC/60Hz, PVDF, 1/2", with FKM (Viton®) body seal, flanged, Cv Value = 0.23 Linear. ²EPDM available with PVC or PP bodies only. ³ANSI flat face flanges are standard, DIN flat face flanges EN 1092-1A are available upon request.

SR50 Pressure Regulating (Reducing) Valves – Maximum recommended pressure drop for EK and EE Series Characterized Control Valves is 20 psi. An additional Chemline SR50 Pressure Regulating (Reducing) valve should be installed for pressure drops higher than 20 psi.



SR50 Pressure Regulating (Reducing)

EK Series Accessories

POSITIONERS

Valve positioners control actuator-valve position, responding to a signal from a process controller, usually electronic (most often 4–20mA) or sometimes pneumatic (3–15 psi). YT Series positioners are easy to mount. They have epoxy coated aluminum enclosures and are also available in 316 stainless steel. All available models are attractively priced:

- **YT1200L: 3–15 psi Pneumatic** – a conventional all-mechanical positioner with NEMA4X enclosure rating
- **YT3303L: 4–20 mA Smart** – a fully digital positioner with intelligent functions like auto calibration, PID control, also theoretical and user defined characterized output. Options include alarms (switch or relay output), 4–20 mA transmitter for position feedback and HART digital communication protocol.
- **YT3400L: 4–20 mA Smart** – explosion-proof version of the YT3303L positioner



YTL3303L Positioner

EE Series Accessories

PSC.2 Local Control – The lockable Local Control Box PSC.2 allows on-site operation and can also be used to set most of the actuator-specific values. It displays valve actual position, messages and parameters of the actuator in full text.

Fieldbus/Blue Tooth Interface – The main board is prepared for the optional installation of modules for all common field bus interfaces or Bluetooth protocol, which enables wireless setting and read-out of diagnostics of the actuator at distances of up to 10 m.

PSCS Communication Software – Actuation thrust/torque and speed, alerts and valve curve correction. The diagnostics function of the communication software PSCS allows to retrieve counting values (such as operating hours, number of start-ups and running time of motor) and sets of running parameters (such as the analogue set value input, actual position value, currently required motor torque and inside temperature of the actuator). The actual values can be graphically displayed and analysed on the computer monitor. Thus the PS-AMS concept allows pro-active maintenance and as a result an increase in process safety.

Space Heater – Recommended for high temperature fluctuations or high humidity, to prevent the build-up of condensation within the enclosure.

Fault Indicator Relay – Fault messages can be transmitted to control boards with a maximum load of 24 VDC/100 mA via a closing contact at terminals 7 and 8. The messages can set via software PSCS or control box PSC.

Fail-Safe Unit PSEP – The Fail-Safe Device PSEP is based on an accumulator with controlled charger, so that a safety position in case of loss of power supply can be freely defined without any mechanical alterations to the actuator.



PSC.2 Local Control



Fail Safe Unit PSEP

EE Series.EK Series.DS.10.24.22