

ChemValve Fluoropolymer Lined Butterfly Valves



VE-CF

SERIES: CST-K

SIZES: 2" to 12"

BODY TYPE: Wafer & Lug³

MATERIALS:

Body: VE-CF Vinyl Ester, Carbon Filled⁴

Disc: PFA covered 316 SS

Seat & SHAFT SEAL: TFM



**Gear Operated
Lug Body Valve**



**Lever Operated
Wafer Body Valve**

ChemValve Type CST-K fluoropolymer lined butterfly valves feature a composite plastic body. These valves are designed for zero leakage in the toughest of corrosive applications up to 130°C (265°F) at 150 psi¹. The high density TFM liner provides superior performance vs. conventional PTFE lined valves. The one-piece shaft/disc is over-moulded with PFA. The vinyl ester body reinforced with carbon and glass fibres is essentially indestructible and has outstanding external corrosion resistance.

Features

- **Exceptional Internal & External Corrosion Resistance**

- **Zero Leakage 150 psi up to 130°C (265°F)**

Composite Body – Carbon and glass reinforced vinyl ester material has excellent mechanical properties:

- High Tensile Strength: High pressure rating
- High Temperature Rating: 130°C (266°F)
- High Impact Strength: Durability and safety

Special TFM Seat and PFA Disc Covering

– The seat is TFM, a high density grade of PTFE. The one piece disc/shaft is 316 SS over-moulded with PFA. Both materials have mechanical properties superior to those of standard PTFE:

- **Low Cold Flow** – More durable and stable when under stress
- **Low Permeability** – The permeability of TFM is 50% less than standard PTFE². Lower permeability means longer valve life on highly corrosive chemicals.
- **Smoother Surface** – Higher abrasion resistance

Light Weight – The CST-K valve is lighter than conventional ductile iron body PTFE lined butterfly valves. Installation and maintenance is much easier and stress on the piping system is lower.

Serviceable – The "split" body can be disassembled and the seat (liner) or disc/shaft part replaced

¹ 150 psi for 2" to 6" sizes, 125 psi for 8" to 12"

² Tested with chlorine gas

³ Embedded stainless steel threaded lug inserts

⁴ VE-CF is vinyl ester with 10% carbon fiber and 10% glass fiber

Mechanical Shaft Seal

Perfect sealing between the TFM seat and PFA disc is maintained under all pressures and temperatures. Three levels of sealing are provided – primary plus two back-ups.

2) Radial (Lip) Sealing

- The compression piece provides a radial seal between the PFA covered shaft and the TFM seat

1) Primary Sealing

- Belleville disc springs provide a leak-free mechanical stem seal.

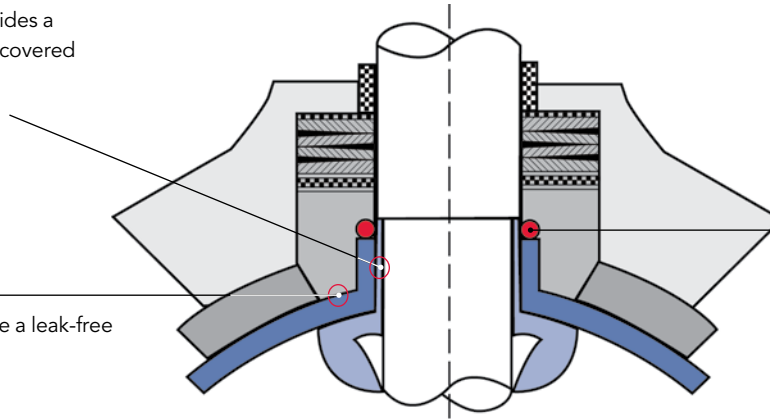

3) Back-Up Seal

- FKM (Viton®) o-ring

Three Levels of Sealing

Integrally Moulded Operator Mounting Flange

- Permits direct mounting of electric or pneumatic actuators
- ISO 5211 standard dimensions

Shaft Bushing

- With inner and outer FKM (Viton®) o-ring seal
- Seals the shaft from the outside and provides vacuum resistance

Bearing

- PTFE coated permanently lubricated bearing

Wide Sealing Face on Liner

- Guarantees a leak-free seal

Precision Machined High Density TFM Seat

- Minimum 3.0 mm thickness

One-Piece Disc/Stem

- PFA 3.0 mm thick is precision over-moulded onto the one-piece 316 SS disc/stem
- Permeation problems are eliminated due to the high density PFA permanently bonded to the stainless steel
- Full vacuum resistance at full-range of temperature and pressures

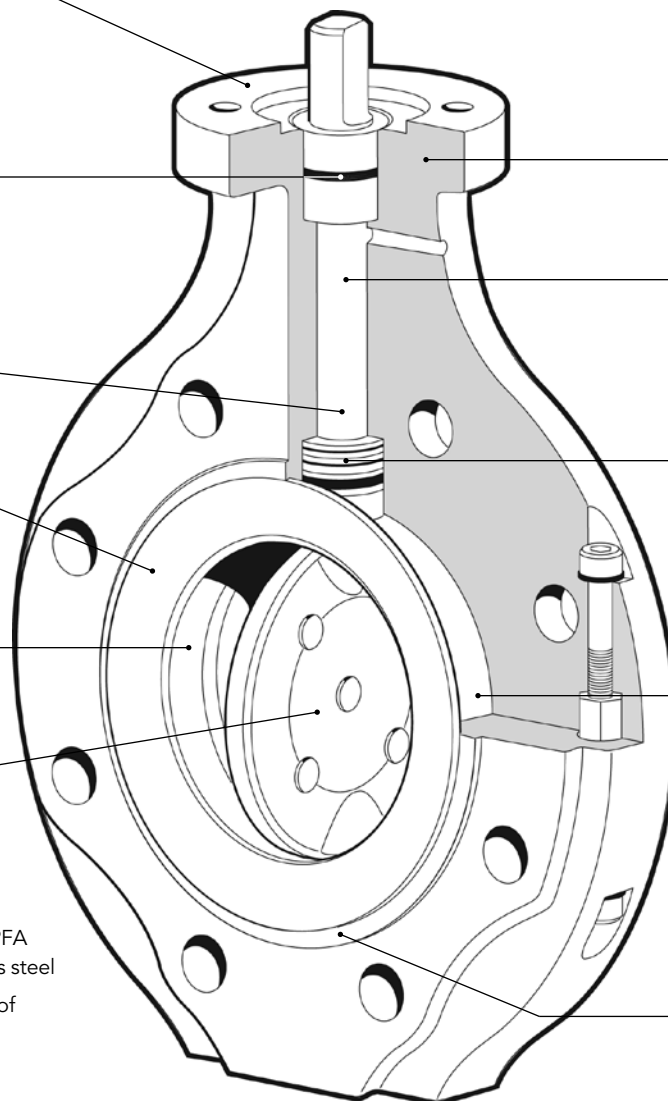

Split Body of VE-CF

- For disassembly. Parts may be replaced.

One-Piece Disc/Stem

- Allows for a thinner disc for higher C_v values and better flow control

Upper Stem Seal Package

- Belleville spring washers provides uniform loading onto the compression piece, pressing the TFM seat against the disc-stem
- Leak-free triple seal system

Resilient Elastomer Backup Pads

- Provide uniform pressure onto the circumference of the disc, ensuring bubble-tight shut off under all operating conditions
- Moulded pads have exact dimensional tolerances for precise shaft torques

Lower Stem Seal Package

- Lower stem seal is the same design as the upper seal

ChemValve CST-K Series Butterfly Valves

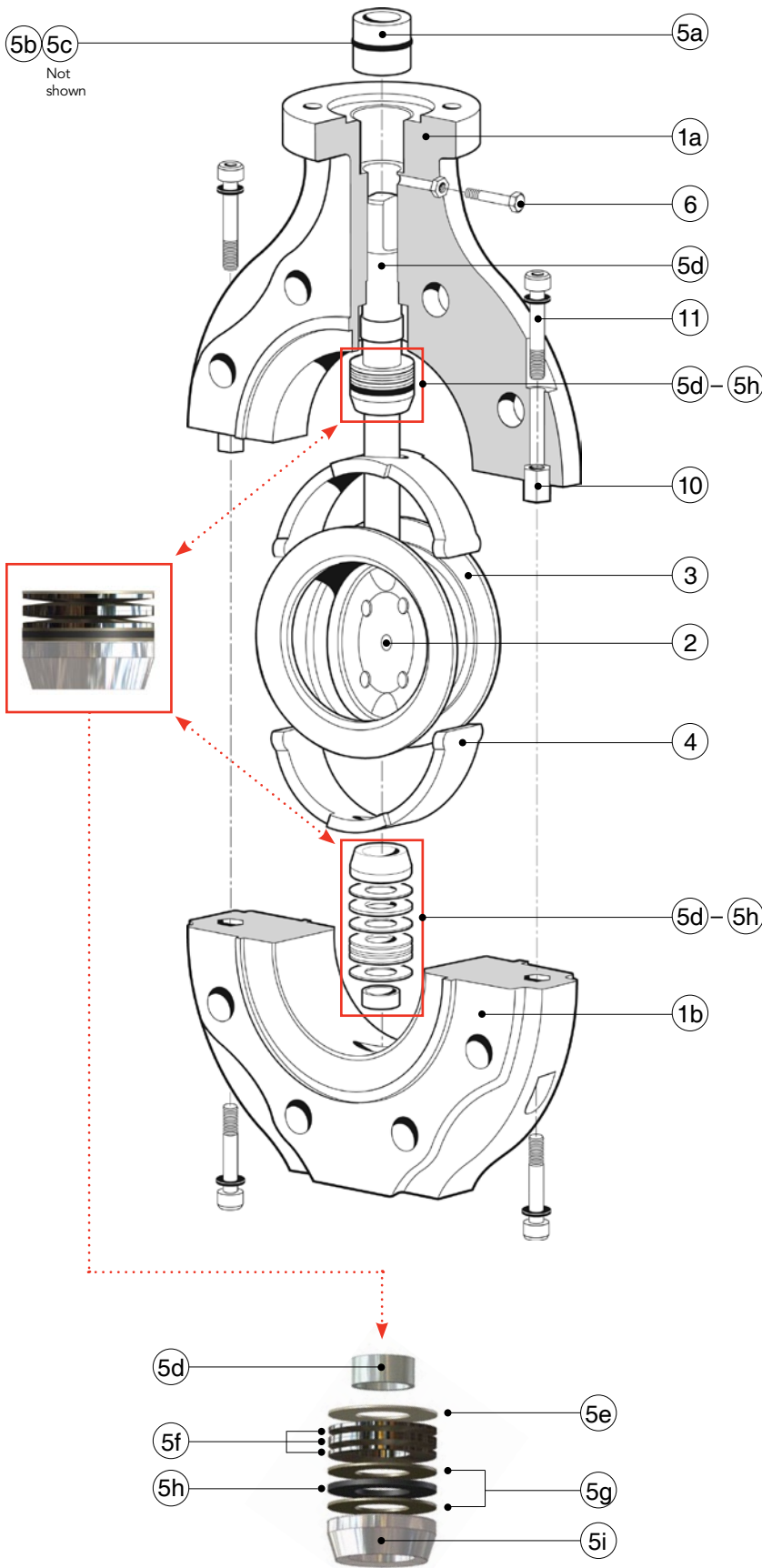

PARTS

▲ Recommended Spare Parts

No.	Part	Pcs.	Materials
1a	Upper Body	1	VE-CF ¹ Composite
1b	Lower Body	1	VE-CF ¹ Composite
2▲	Disc/Shaft	1	PFA covered 316 SS
3▲	Seat (Liner)	1	TFM
4▲	Seat Back-up	1	FKM (Viton®)
5a	Shaft Bushing	2	POM Polyacetal
5b	Outer Bushing O-Ring	2	FKM (Viton®)
5c	Inner Bushing O-Ring	2	FKM (Viton®)
5d	Shaft Bearing	2	PTFE Covered
5e	Washer	2	Synthetic
5f	Belleville Spring Washer	2 sets	Spring Steel
5g	Composite Washer	2	Garlock IFG 5500
5h	Elastomer Washer	1	FKM (Viton®)
5i	Compression Piece	1	316SS
6	Atex Sniffer Port ²	1	SS
7	Hand Lever	1	304 SS
8	Position Lock Plate	1	304 SS
9	Gear Operator	1	FRP
10	Coupling	2	304 SS
11	Bolt/Washer	4	316 SS

¹VE-CF=Vinyl Ester Carbon Fibre Filled: 10% carbon fibre and 10% glass fibre.

²Optional provision for fugitive emissions monitoring.

BODY TYPES

Wafer

- Full circle of bolt holes. Flange bolts slip through the holes.

Lug

- 316 SS lugs are moulded into the composite (thermoset plastic) valve body. ASME threads come with ANSI valve bodies, metric threads are supplied in metric bodies. Lugs allow the valve to operate in dead end service from either side of the valve, under full rated pressure.

ChemValve CST-K Series Butterfly Valves



DIMENSIONS INCHES

Size	L	A	B*	C	n	e	d	D ₁	D ₂	D ₃	E	G ₁	G ₂	H ₁	H ₂
2"	1.69	0.24	1.22	4.75	4	0.75	1.97	1.22	7.13	6.3	9.06	6.6	2.5	2.36	5.12
2-1/2"	1.81	0.43	1.89	5.50	4	0.75	2.56	1.89	7.87	6.3	9.06	6.6	2.5	3.35	5.75
3"	1.81	0.67	2.48	6.00	4	0.75	3.15	2.48	8.50	6.3	9.06	6.6	2.5	4.25	6.50
4"	2.05	1.06	3.54	7.50	8	0.75	3.94	3.54	9.72	6.3	10.63	6.6	2.5	4.80	7.28
6"	2.20	1.85	5.39	9.50	8	0.87	5.91	5.39	11.89	6.3	12.80	6.6	2.5	5.79	8.54
8" Lever	2.36	2.80	7.44	11.75	8	0.87	7.87	7.44	14.33	6.3	13.74	6.6	2.5	7.17	9.65
8" Gear	2.36	2.80	7.44	11.75	8	0.87	7.87	7.44	14.33	6.3	13.74	6.6	2.5	7.17	9.65
10"	2.68	3.62	9.41	14.25	12	1.02	9.84	9.41	17.48	6.3	13.74	6.6	2.5	8.07	10.63
12"	3.07	4.41	11.42	17.00	12	1.02	11.81	11.42	20.24	11.8	13.74	9.5	3.9	9.06	12.13

*B=Minimum inside diameter (I.D.) of mating pipe. If I.D. of pipe is B dimension or less, the inside of pipe and must be chamfered or spacers provided. Consult Chemline.

DIMENSIONS INCHES

Size	H ₃		Lug Threads	I	J	K	L	M	P	Q	R	S	T
	Lever	Gear											
2"	1.81	-	-	5/8" - 11 UNC	2.76	4 x 0.35	2.20	0.14	0.43	0.75	4.02	4.79	2.50
2-1/2"	1.81	-	-	5/8" - 11 UNC	2.76	4 x 0.35	2.20	0.14	0.43	0.75	4.02	4.79	2.50
3"	2.17	-	-	5/8" - 11 UNC	2.76	4 x 0.35	2.20	0.14	0.43	0.75	4.02	4.79	2.50
4"	2.17	-	-	5/8" - 11 UNC	2.76	4 x 0.35	2.20	0.14	0.55	0.98	4.02	4.79	2.50
6"	2.17	-	-	5/8" - 11 UNC	2.76	4 x 0.35	2.20	0.14	0.67	1.18	4.02	4.79	2.50
8" Lever	2.17	-	-	3/4" - 10 UNC	4.02	4 x 0.43	2.80	0.14	0.75	1.02	5.98	4.79	2.50
8" Gear	-	3.6	14.29	3/4" - 10 UNC	4.02	4 x 0.43	2.80	0.14	0.75	1.02	5.98	4.79	2.50
10"	-	3.6	15.27	7/8" - 9 UNC	4.02	4 x 0.43	2.80	0.14	0.87	1.18	5.98	4.79	2.50
12"	-	4.3	19.68	7/8" - 9 UNC	4.02	4 x 0.43	2.80	0.14	0.87	1.18	5.98	7.40	3.95

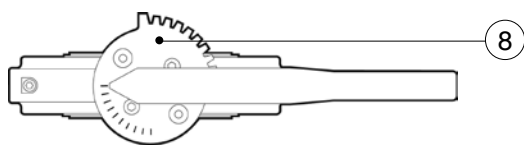
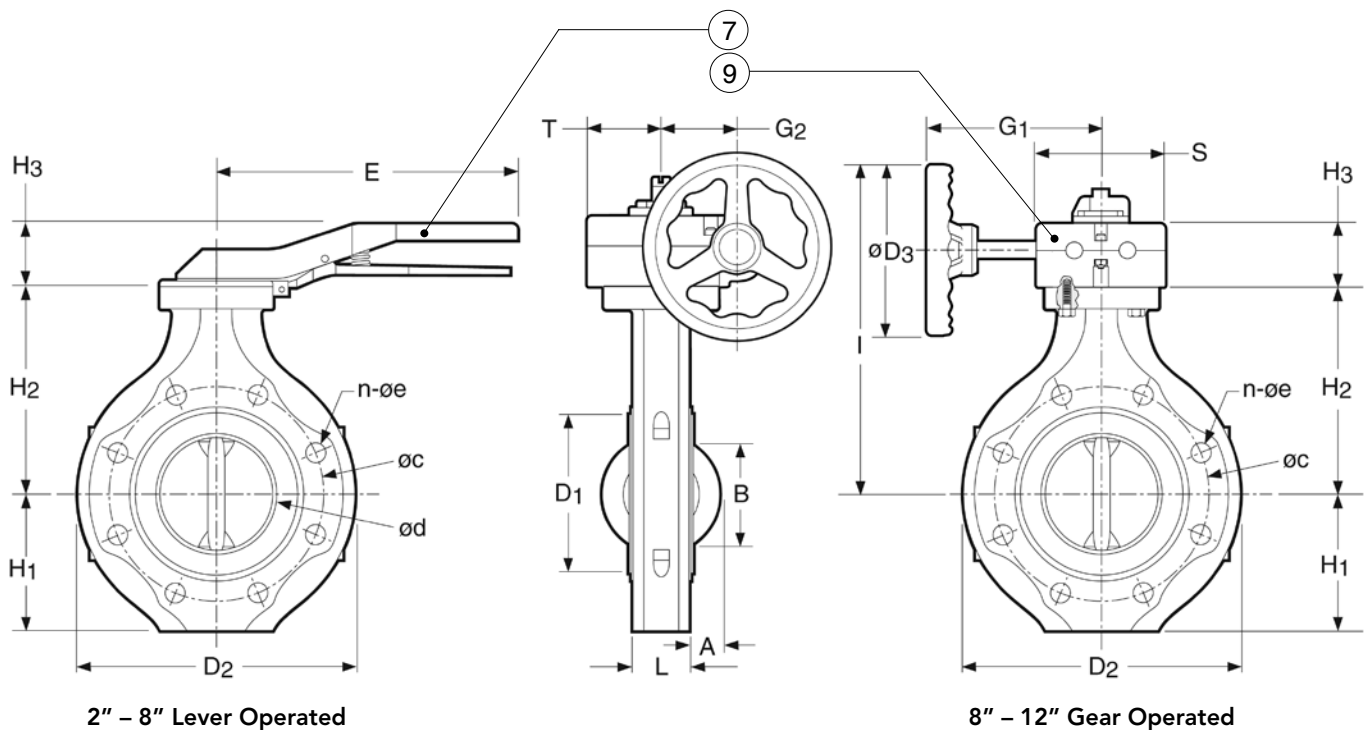

ChemValve CST-K Series Butterfly Valves

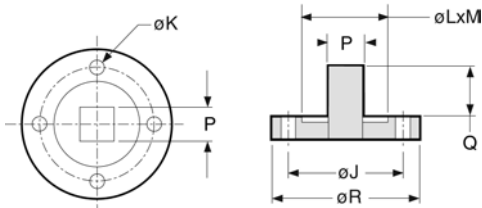

Square Shaft: 2" to 12"

Cv VALUES VS. DISC ANGLE							FLANGE BOLT TORQUES	WORKING PRESSURES	TFM Seat/ PFA Disc
	15°	30°	45°	60°	75°	90°	Max. Recommended Torques Ft.-Lbs.	PSI -25 to 105°C -13 to 221°F	130°C 266°F
2"	6.7	20.1	51.5	114.	179.	224.	25.9	150	150
2-1/2"	9.3	27.8	71.0	157.	247.	309.	29.6	150	150
3"	13.6	40.9	105.	232.	364.	455.	33.3	150	150
4"	20.4	61.1	156.	346.	543.	679.	37.0	150	150
6"	52.0	156.0	399.	884.	1,387.	1,734.	51.8	150	150
8"	106.	318.	814.	1,804.	2,830.	3,538.	63.0	150	125
10"	157.	471.	1,203.	2,668.	4,185.	5,232.	70.4	150	125
12"	226.	679.	1,734.	3,845.	6,032.	7,540.	77.8	150	125

WEIGHTS LBS.

Size	Wafer Body Valve		Lug Body Valve	
	with Hand Lever	with Gear Op	with Hand Lever	with Gear Op
2"	8.36	11.0	12.8	15.4
2-1/2"	10.6	13.2	17.2	19.8
3"	12.8	15.4	19.6	22.2
4"	16.3	22.4	26.2	32.3
6"	25.1	30.6	37.9	43.3
8" Lever	40.5	-	58.3	-
8" Gear	-	44.9	-	62.7
10"	58.1	62.5	77.4	81.8
12"	85.6	98.3	129.6	142.3

ChemValve as a Control Valve

ChemValve's streamlined disc provides excellent flow control. In general for optimum system control, a valve should operate between 30% and 70% of valve opening (rotation of disc). The flow curve (Figure 5) shows the flow rate versus valve opening to be relatively linear in this range. With a choice of actuators and positions, the CST-K becomes a cost effective control valve.

TECHNICAL STANDARDS

Flange Connections – ANSI CL150, PN10-16 (sizes DN050 to 300) and PN10 (sizes DN200 to 300) are available

Face-to-Face Dimensions – Conform to ISO 5752 Basic Range 20

Operator Mounting Flange – Conforms to ISO 5211 (standard actuator mounting) dimensions

Shaft Dimensions – Double D 2" to 6", Square shaft 8" to 12". Dimensions are according to ISO 5211.

Leakage Testing – Each valve is factory tested before shipment to confirm zero leakage. The test is EN 1226-1/P12, leakage rate A.

Fugitive Emissions – Certificate of compliance for TA Luft standard 5.2.6.4. ChemValve CST-K valves reach this standard by TA Luft ("Technical Instructions on Air Quality Control") after 4,000 cycles with standard production valves while most competitors reach only 2,000 with specially prepared valves.

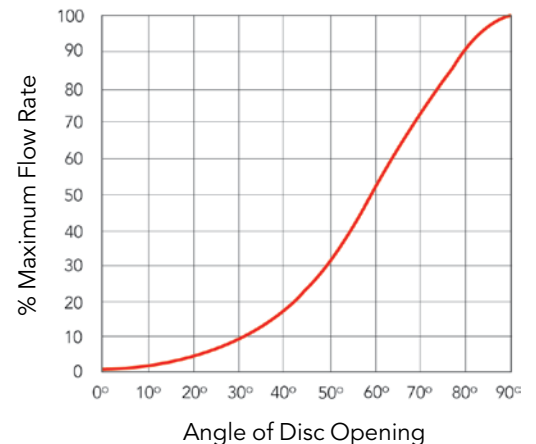

Figure 5: Flow Curve

Electric & Pneumatic Actuation

Pneumatic and Electric Actuators

- A complete range of actuators and control accessories are available, mounted to valves using PPG plastic brackets and stainless steel couplings. Refer to separate data sheets.
- All actuators are CSA approved, have NEMA 4S enclosures, stainless steel hardware and permanently lubricated gear train



E Series Electric

- ChemValves up to 4"
- up to 1,335 in-lbs torque
- industrial process with minimal use of metal
- Glass-filled Polyamide



V Series Electric

- ChemValves up to 12"
- up to 8,850 in-lbs torque
- On-Off (2/3 wire) adjustable travel, optional failsafe, modulating, BUS
- Visual feedback, 2 feedback switches, optional 2 extra feedback switches, feedback potentiometer and feedback transmitter



PA Series Pneumatic

- ChemValves up to 12"
- up to 10,660 in-lbs torque
- industrial process submerged
- bleach/water washdown
- Rilsan-coated aluminum

ChemValve CST-K Series Butterfly Valves



VACUUM RATING

- 29.9 inches mercury

OPTIONS & ACCESSORIES

Consult Chemline for more details

- **Alternate Seats**
- **Alternate Discs**
- **Electrically or Pneumatically Actuated**
- **Chain Wheel Operator**
- **Gear Operator** on 1-1/2" to 6"
- **Locking Capability** on gear operators
- **Shaft Extensions**
- **Limit Switches** for open and/or closed position indication

SAMPLE SPECIFICATION

Note: Specification below is for valves with TFM seat, FKM seat backings and PFA covered disc/shaft. The VE- CF body valve is available with other seat, seat backing and disc materials. See the data sheet.

1. All fluoropolymer lined butterfly valves 2" to 12" will be ChemValve Type CST-K from Chemline Plastics Limited.
2. Pressure rating will be 150 psi.¹
3. Body material will be VE-CF composite, vinyl ester carbon filled with 10% carbon and 10% glass fibers.
4. Body will be "split" design, permitting disassembly and repair.
5. Wafer style body will have a full set of locating bolt holes, dimensions according to ASME/ANSI B16.5 Class CL 150.
6. Lug body will have a full set of 304 SS moulded-in lugs. Lug thread and bolt pattern dimensions will be according to ASME/ANSI B16.5 Class CL 150. Lugs will be designed for dead end service, full pressure rating when valve is installed either side.
7. Disc/shaft will be one-piece design, 316 stainless steel, over-moulded with minimum 2.5 mm thickness of PFA.
8. Mechanical shaft seals at the top and bottom of the disc/shaft will be a spring packs with 316SS compression piece, Belleville disc springs, elastomeric and composite washers and permanently lubricated bearing.
9. Seat will be TFM, a high-density grade of PTFE, minimum 3.0 mm thick.
10. Elastomeric seat back-up pads will be precision moulded of FKM (Viton®).
11. Operator mounting flange and shaft dimensions have standard dimensions according to DIN 5211 for exchange of manual operators or actuators. Fasteners used to mount operators will not be pressure retaining.
12. Hand lever operator (lever and position lock plate) will be solid 304 stainless steel.
13. Gear operator will be of corrosion resistant composite plastic construction (FRP) with all exposed metal parts (bolts, hand wheel shaft) of 304 stainless steel. Operators will have visual valve position indicator, also open/close travel stops that allow adjustment of the disc closing.

¹ At maximum temperatures, pressure ratings are lower than the maximum 150 psi. Refer to the manufacturer's data.

ORDERING EXAMPLE

ChemValve Butterfly Valves	CST	P	T	V	K	040	W	A1	-L
Disc	P – PFA covered 316SS F – Polished 316 SS	C – Conductive PFA T – Grade 2 Titanium	S – 316 Stainless Steel H – Hastelloy C22						
Seat (Liner)	T – TFM F – Conductive FDA Grade TFM	C – Conductive TFM							
Seat Back-ups	S – Silicone V – FDA grade FKM (Viton®) E – EPDM								
Body	K – VE-CF Glass and Carbon Reinforced Vinyl Ester								
DN Size	020 – 2" 060 – 6"	025 – 2-1/2" 080 – 8"	030 – 3" 100 – 10"	040 – 4" 120 – 12"	050 – 5"				
Body Type	W – Wafer E – Lug								
Flange Standard	A1 – ANSI 150 D1 – DIN PN10 D2 – DIN PN16								
Operator	L – Hand Lever G – Gear Operator								

Example: CST-K Series Butterfly Valve, PFA covered disc/shaft, TFM seat, FKM (Viton®) seat back-ups, VE-CF vinyl ester composite body, 4", wafer body, ANSI 150, lever operated.

VALVE TAG

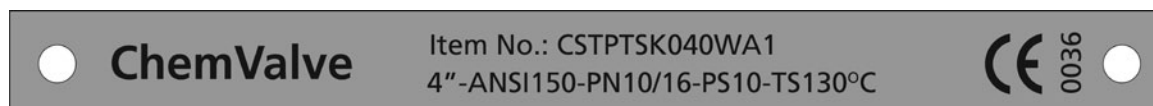

CST-K Series.DS.01.17.23