



SOLIBA PLUS

METAL LEVEL DETECTOR

For heavy and voluminous materials: stones, pebbles

This detector has a very strong special protection. In fact, it consists of a cast aluminum metal cage and a level detector for solid SOLIBA or SOLIBA EX P ATEX certified in zones 21, 22 (dust).

The metal case allows, without any risk of deterioration, the high point level detection of voluminous bulk solids as well as the stop of all types of conveyor systems when dealing with excessive-height materials. A few application examples: - Gravel pits - Belt conveyors - All types of conveyor systems

Available in 2 versions. See page 2



100 % made in France



Fixcab

Operation mode	By tilting
Electric characteristics	240 VCA 50/60 Hz
Cut-out power	See SOLIBA or SOLIBA EX P
Maximum temperature	See SOLIBA or SOLIBA EX P
Protection index	IP 68
Housing	Cast aluminium
Type of cable	Neoprene ou HR HY 3X1 mm ²
Float weight without cable	2 495 g

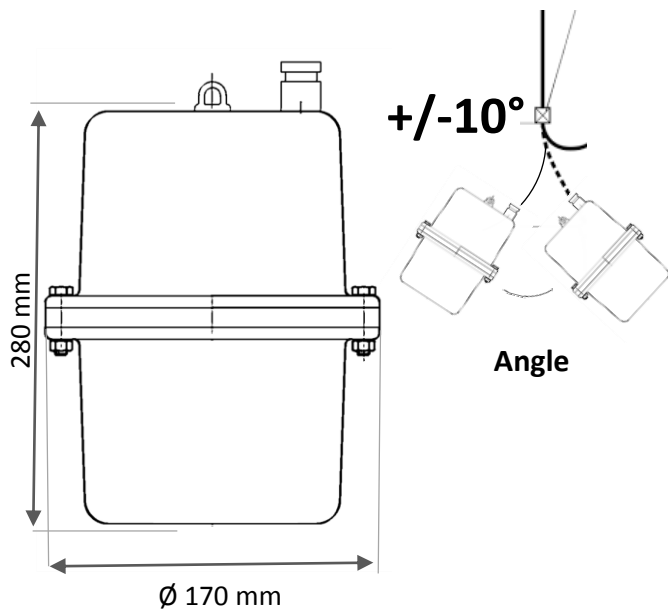

Dimension

OPERATION

STOP OF CONVEYORS

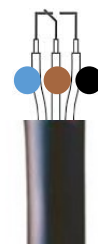
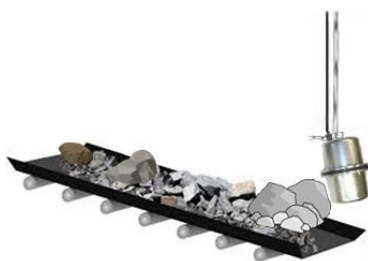
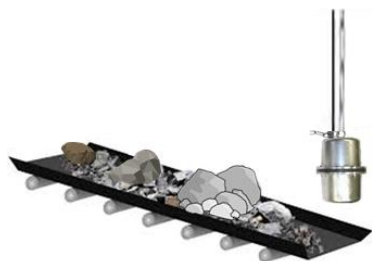

When bulk solids are conveyed by belt conveyors, the SOLIBA PLUS is suspended vertically.

When an object is too big (or oversized), the level sensor tilts and stops the conveyor

Connection

 Metal cage + SOLIBA

FILLING

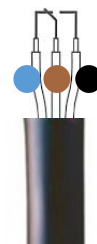

SOLIBA PLUS EX P



When the silo fills up, the level sensor is suspended vertically.

When the high level is reached, the level sensor tilts and stops filling the silo

Connection

Metal cage + SOLIBA EX P
For use only in hazardous areas classified 21,22