



AT 120 HRHY

LEVEL SWITCH FOR AGITATED LIQUIDS
For aggressive and / or corrosive liquids

This float level switch (NO or NC) allows the automation of small pumps (up to 1.5 HP) thanks to its microswitch of 20 A (400V) or unlimited through a relay.

Thanks to its wide switching angle of 120°, the BIP STOP protects the pump's engine and the electrical panels from jerking. This feature is highly appreciated in agitated liquids.



100 % made in France



Fixcab

Allowed fluid densities	0,80 à 1,10 g/cm ³
Electric characteristics	250 VCA /VCC 50/60 Hz
Cut-out power	20 (8) A
Maximum pressure	4 bars
Maximum temperature	90 °C
Protection index	IP 68
Housing	Copolymer polypropylene + HR HY
Type of cable	HR HY
Float weight without cable	295 g

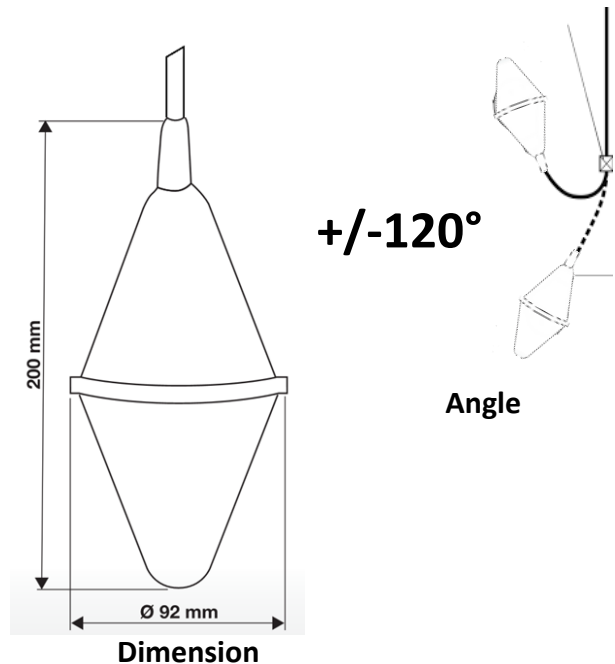

EMPTYING

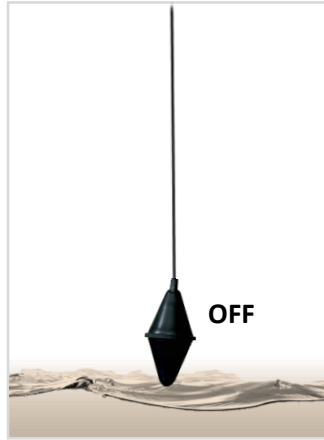
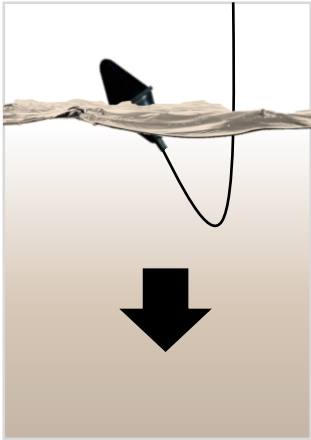

The pump empties the tank.

When the fluid level drops below the float, the power goes off

Connection

Installations examples



 Connection to the pump.



 Connecting to an alarm

FILLING

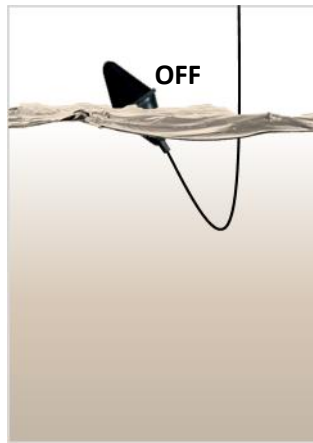
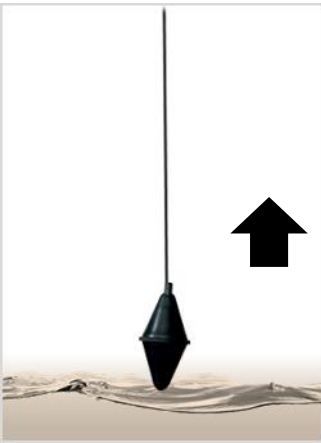

The pump fills the tank.

When the liquid reaches the float, it tilt shut off the power to the pump

Connection



 Fixed with optional ballast