

Description

TL448K6D-VR is a highly integrated processing module that provides all infrastructure to enable SteamVR tracking in an ultra compact form factor.

This module enables customers integrating SteamVR to mount acquisition electronics directly to a 2 layer sensor flex, greatly simplifying device interconnect, cost, size, weight and assembly time.

Modules are produced in volume, programmed with the latest SteamVR firmware and functionally tested in an automated test fixture.

Modules also include requisite IMU calibrations to simplify tracked object production test.

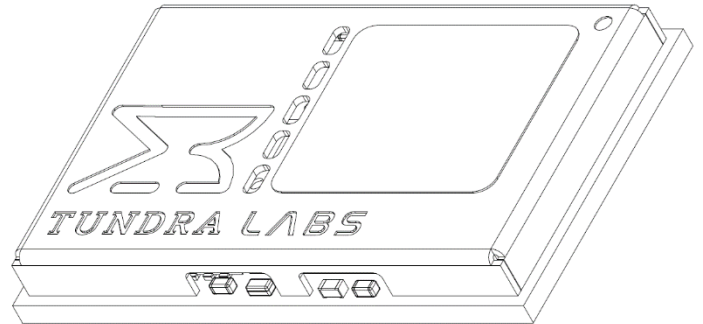

Features

- Atmel ATSAMG55 Processor
 - 512 kByte Flash
 - 176 kByte SRAM
 - 120 MHz ARM Cortex-M4
 - Floating Point Processing Unit
 - DSP Instructions
 - USB 2.0 Full Speed
 - 12bit 500ksps ADC
 - 7 Flexcom units supporting SPI, I2C, I2S, USART and UART
 - SWD Programming interface
 - 14 Exposed IO Pads
- Lattice ICE40HX8K-CB132 FPGA
 - 7,680 LUT4s
 - 128 kbits RAM4k Memory Blocks
 - 2 Phase Locked Loops
 - 82 exposed IO pads
- Nordic nRF52832 RF Processor
 - 2.4GHz ISM Radio
 - ± 10 ppm Stability XTAL
 - 64MHz ARM Cortex-M4
 - Floating Point Processing Unit
 - 512 kByte Flash
 - 64 kByte SRAM
 - Near Field Communication
 - SPI/2-wire/I²S/UART/PDM/QDEC
 - 12bit 200ksps ADC
 - 10 Exposed IO Pads

- TDK/Invensense ICM-20602
 - 3 Axis Accelerometer
 - $\pm 2g/4g/8g/16g$ FSR
 - 3 Axis Gyroscope
 - $\pm 250/500/1000/2000$ dps FSR
- 48MHz MEMs Reference Clock
 - ± 25 ppm Stability
- Low Power 32.768kHz MEMs Clock
 - ± 100 ppm Stability

Applications

- 6 Degree of Freedom Tracking
 - Virtual Reality (SteamVR)
 - Standalone Tracking Systems
- Precision Timing Capture Data Acquisition for all
- Tracking Applications
- Eye Tracking
- Sensor Fusion
- Free Space Optical Communication
- Video Encoding/Decoding
- High Performance Motor Control
- Internet of Things (IoT)
- Functional Safety Systems
- USB Human Interface Device
 - SteamVR Input Compatible
- Industrial Sensors
- Wireless networks
 - 2.4GHz Proprietary networks
 - Bluetooth Low Energy
 - Bluetooth 5
 - ANT
 - BLE Mesh

Block Diagram

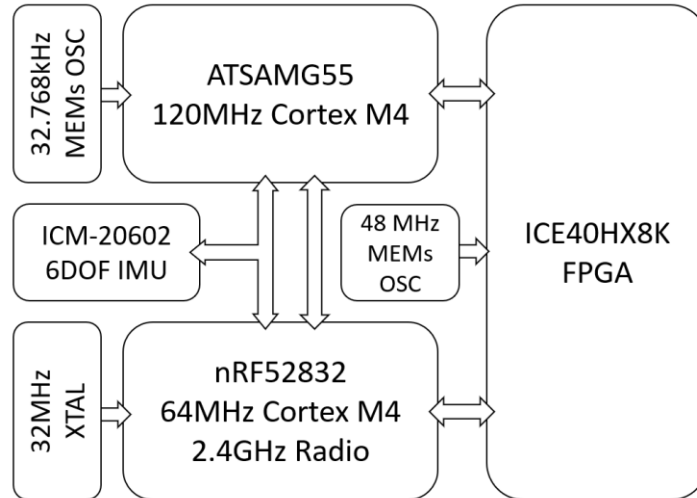

Pin Configuration

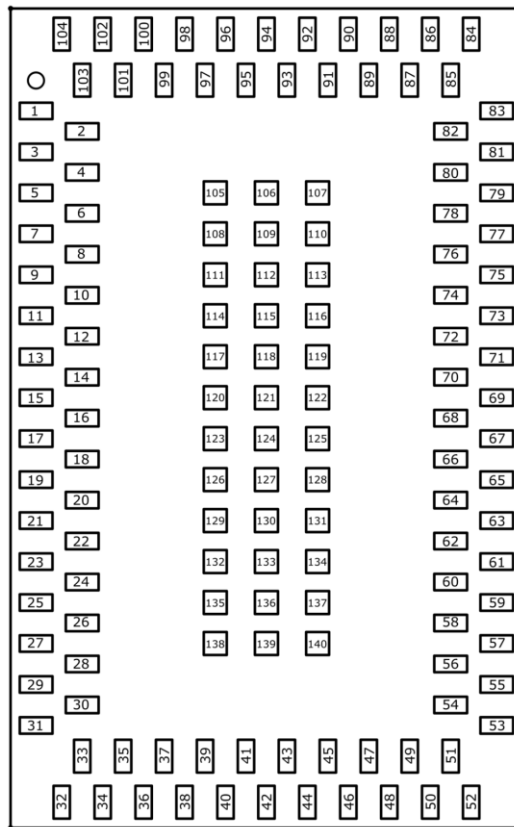

(Top View)

Signal Description

Pad	Net Name	Device	Device IO Pin	Description
1	SENSOR_A22	FPGA	IOL_25A (N1)	
2	SENSOR_B22	FPGA	IOL_25B (P1)	
3	SENSOR_A23	FPGA	IOB_56 (P2)	
4	SENSOR_B23	FPGA	IOB_59 (P3)	
5	SENSOR_A24	FPGA	IOL_18B (K4)	
6	SENSOR_B24	FPGA	IOB_72 (L4)	
7	SENSOR_A25	FPGA	IOB_63 (M4)	
8	SENSOR_B25	FPGA	IOB_73 (P4)	
9	SENSOR_A26	FPGA	IOB_71 (L5)	
10	SENSOR_B26	FPGA	IOB_78 (L6)	
11	SENSOR_A27	FPGA	IOB_77 (M6)	
12	SENSOR_B27	FPGA	IOB_74 (P5)	
13	SENSOR_A28	FPGA	IOB_87 (L8)	
14	SENSOR_B28	FPGA	IOB_103_CBSEL0 (L9)	
15	SENSOR_A29	FPGA	IOB_79 (M7)	
16	SENSOR_B29	FPGA	IOB_91 (M9)	
17	SENSOR_A30	FPGA	IOR_111 (L12)	
18	SENSOR_B30	FPGA	IOR_115 (K12)	
19	SENSOR_A31	FPGA	IOB_89 (P9)	
20	SENSOR_B31	FPGA	IOB_104_CBSEL1 (P10)	
21	SENSOR_A32	FPGA	IOR_118 (J12)	
22	SENSOR_B32	FPGA	IOR_120 (H12)	
23	GND	-	-	
24	USB_MCU_D_N	MCU	PA21/USB_N (F4)	
25	USB_MCU_D_P	MCU	PA22/USB_P (G5)	
26	VBUS_IN	MCU	PA20/AD3 (F1)	This pin is not 5V tolerant. Use voltage divider to scale voltage to 3.3V when USB is connected
27	GND	-	-	
28	SPI_SCLK	MCU	PA15 (G6)	SPI Master for communication with Peripheral MCU, Trackpad or other supported SPI Device
29	SPI_MOSI	MCU	PA06 (G7)	
30	SPI_MISO	MCU	PA05 (D6)	
31	MCU_GPIO_0	MCU	PA23 (F5)	Haptics Driver Control
32	MCU_GPIO_1	MCU	PA10 (E5)	Haptics Power Enable
33	SPI_CSN	MCU	PA09 (A1)	Chip Select output for SPI devices
34	MCU_GPIO_2	MCU	PB00/AD4 (E2)	ADC Capable for Trigger Sensor or IPD
35	MCU_GPIO_3	MCU	PA16 (F6)	SteamVR Menu Button
36	UART_TX	MCU	PA03 (C6)	UART interface for Firmware Debug
37	UART_RX	MCU	PA04 (C5)	

Pad	Net Name	Device	Device IO Pin	Description
38	GND	-	-	
39	GND	-	-	
40	RF_ANT	Radio	ANT (D1)	
41	GND	-	-	
42	GND	-	-	
43	NFC2	Radio	P0.10/NFC2 (G5)	
44	NFC1	Radio	P0.09/NFC1 (G6)	
45	RADIO_GPIO_1	Radio	P0.00/XL1 (D7)	Control of Red LED for device
46	RADIO_GPIO_3	Radio	P0.02/AIN0 (C6)	Control of Green LED for device
47	RADIO_GPIO_2	Radio	P0.01/XL2 (C7)	Control of Blue LED for device
48	RADIO_GPIO_4	Radio	P0.03/AIN1 (D6)	
49	RADIO_GPIO_6	Radio	P0.05/AIN3 (E7)	
50	RADIO_GPIO_5	Radio	P0.04/AIN2 (E6)	
51	RADIO_GPIO_8	Radio	P0.07 (F6)	
52	RADIO_GPIO_7	Radio	P0.06 (F7)	
53	FPGA_GPIO_9	FPGA	IOR_140_GBIN3 (F14)	
54	FPGA_GPIO_8	FPGA	IOR_129 (G12)	
55	FPGA_GPIO_7	FPGA	IOR_148 (E14)	
56	FPGA_GPIO_6	FPGA	IOR_137 (F12)	
57	FPGA_GPIO_5	FPGA	IOR_152 (D14)	
58	FPGA_GPIO_4	FPGA	IOR_147 (E12)	
59	FPGA_GPIO_3	FPGA	IOR_154 (C14)	
60	FPGA_GPIO_2	FPGA	IOR_160 (D12)	
61	FPGA_GPIO_1	FPGA	IOR_161 (B14)	
62	SENSOR_B1	FPGA	IOT_179 (A11)	
63	SENSOR_A1	FPGA	IOT_174 (C11)	
64	SENSOR_B2	FPGA	IOT_177 (D10)	
65	SENSOR_A2	FPGA	IOT_178 (D11)	
66	SENSOR_B3	FPGA	IOT_181 (A10)	
67	SENSOR_A3	FPGA	IOT_186 (C10)	
68	SENSOR_B4	FPGA	IOT_190 (C9)	
69	SENSOR_A4	FPGA	IOT_188 (D9)	
70	SENSOR_B5	FPGA	IOT_200 (C7)	
71	SENSOR_A5	FPGA	IOT_197_GBIN1 (A7)	
72	SENSOR_B6	FPGA	IOT_207 (D6)	
73	SENSOR_A6	FPGA	IOT_202 (D7)	
74	SENSOR_B7	FPGA	IOT_206 (C6)	
75	SENSOR_A7	FPGA	IOT_198_GBIN0 (A6)	
76	SENSOR_B8	FPGA	IOL_8A (D4)	
77	SENSOR_A8	FPGA	IOT_211 (D5)	
78	SENSOR_B9	FPGA	IOT_212 (C5)	

Pad	Net Name	Device	Device IO Pin	Description
79	SENSOR_A9	FPGA	IOT_208 (A5)	
80	SENSOR_B10	FPGA	IOT_221 (C4)	
81	SENSOR_A10	FPGA	IOT_219 (A4)	
82	SENSOR_B11	FPGA	IOL_4A (C3)	
83	SENSOR_A11	FPGA	IOT_222 (A3)	
84	SENSOR_A12	FPGA	IOT_223 (A2)	
85	SENSOR_B12	FPGA	IOT_225 (A1)	
86	SENSOR_A13	FPGA	IOL_2A (B1)	
87	SENSOR_B13	FPGA	IOL_2B (C1)	
88	SENSOR_A14	FPGA	IOL_8B (E4)	
89	SENSOR_B14	FPGA	IOL_9A (F4)	
90	SENSOR_A15	FPGA	IOL_4B (D3)	
91	SENSOR_B15	FPGA	IOL_5A (D1)	
92	SENSOR_A16	FPGA	IOL_10B (G4)	
93	SENSOR_B16	FPGA	IOL_10A (H4)	
94	SENSOR_A17	FPGA	IOL_9B (F3)	
95	SENSOR_B17	FPGA	IOL_5B (E1)	
96	SENSOR_A18	FPGA	IOL_13B_GBIN7 (G1)	
97	SENSOR_B18	FPGA	IOL_13A (G3)	
98	SENSOR_A19	FPGA	IOL_12A (J3)	
99	SENSOR_B19	FPGA	IOL_12B (J1)	
100	SENSOR_A20	FPGA	IOL_23A (L1)	
101	SENSOR_B20	FPGA	IOL_18A (K3)	
102	SENSOR_A21	FPGA	IOL_23B (M1)	
103	SENSOR_B21	FPGA	IOB_64 (M3)	
104	VCC_3V3_CORE	-	-	3V3 Power Input
105	SENSOR_VCC_EN3	FPGA	IOR_136 (G11)	Bank 3 Sensor Power Control (optional)
106	SENSOR_VCC_EN1	FPGA	IOR_146 (E11)	Bank 1 Sensor Power Control (optional)
107	FPGA_GPIO_14	FPGA	IOL_14B (H3)	
108	SENSOR_VCC_EN4	FPGA	IOR_128 (H11)	Bank 4 Sensor Power Control (optional)
109	SENSOR_VCC_EN2	FPGA	IOR_144 (F11)	Bank 2 Sensor Power Control (optional)
110	FPGA_GPIO_13	FPGA	IOR_119 (J11)	
111	GND	-	-	
112	GND	-	-	
113	FPGA_GPIO_12	FPGA	IOR_116 (K11)	
114	FPGA_GPIO_11	FPGA	IOR_109 (M12)	
115	VCC_1V2	-	-	FPGA 1.2V Linear Power Supply Output, Test Pad - Do not connect in application
116	VCC_1V2	-	-	
117	VCC_3V3_CORE	-	-	3V3 Power Input
118	GND	-	-	
119	FPGA_GPIO_10	FPGA	IOR_117 (K14)	

Pad	Net Name	Device	Device IO Pin	Description
120	GND	-	-	
121	GND	-	-	
122	GND	-	-	
123	MCU_SWCLK	MCU	PB07/SWCLK (B3)	
124	FPGA_MCLK	FPGA	IOR_141_GBIN2 (G14)	48MHz MEMs Clock output
125	Not Connected	-	-	This pad is floating however it can be used to detect if the module orientation is correct by pulling up, it will be shorted to ground if the module is installed 180deg rotated.
126	NRST	MCU	NRST (B6)	
127	VCC_3V3_CORE	-	-	3V3 Power Input
128	VCC_3V3_CORE	-	-	3V3 Power Input
129	SCL	MCU	PB02/AD6 (E1)	I2C Bus Master for Battery Management
130	MCU_SWDIO	MCU	PB06/SWDIO (C4)	
131	X32p768kHz_OUT	MCU	PA07/XIN32 (E7)	Output of 32kHz reference oscillator, can be used as a clock reference for an additional, off module MCU. Recommended to keep this connection short, optionally clock reference should be buffered to prevent excessive loading.
132	SDA	MCU	PB03/AD7 (D2)	I2C Bus Master for Battery Management
133	GND	-	-	
134	NRF_SWO	Radio	P0.18 (H2)	
135	POWER_EN	MCU	PA08/XOUT32 (F7)	Output: FPGA Power EN (no connect)
136	NRF_SWDIO	Radio	SWDIO (G1)	
137	NRF_nRST	Radio	P0.21/nRESET (H1)	
138	MCU_GPIO_5	MCU	PB04 (A6)	Recommended for System Button and hardware power on circuit
139	MCU_GPIO_4	MCU	PA17/AD0 (F3)	Analog/Digital Capable GPIO Trackpad
140	NRF_SWDCCLK	Radio	SWDCCLK (F1)	

Internal Device Connections

MCU to FPGA

Name	MCU Pin	FPGA Pin
FPGA_DATA_RDY	PB09 (A5)	IOR_112 (N14)
FPGA_MCU_1/FPGA_CDONE	PB05 (B2)	IOR_114 (L14)
FPGA_MCU_1/FPGA_CDONE	PB05 (B2)	CDONE (M10)
FPGA_MCU_2	PA02 (B4)	IOB_82_GBIN4 (P8)

FPGA_nCS	PA11 (C2)	IOB_108_SS_B (P13)
FPGA_MISO	PA12 (C3)	IOB_105_SDO (M11)
FPGA_nRST	PA00 (C7)	IOL_14A_GBIN6 (H1)
FPGA_MOSI	PA13 (D1)	IOB_106_SDI (P11)
FPGA_CRESET	PA18 (E3)	CRESET_B (L10)
FPGA_SCLK	PA14 (E4)	IOB_107_SCK (P12)

MCU to Radio

Net Name	MCU Pin	Radio Pin
FLEX_A_MISO	PB11 (B1)	P0.13 (G4)
FLEX_A_SCLK	PB01/AD5 (D3)	P0.14 (H5)
FLEX_A_MOSI	PB10 (D4)	P0.12 (H6)
NRF_nCS	PA19/AD2 (F2)	P0.11 (F4)

MCU to IMU

Net Name	MCU Pin	IMU Pin
IMU_INT	PA24 (A3)	INT (6)
FLEX_A_MISO	PB11 (B1)	SA0/SDO (4)
FLEX_A_SCLK	PB01/AD5 (D3)	SCL/SPC (2)
FLEX_A_MOSI	PB10 (D4)	SDA/SDI (3)
IMU_nCS	PA01 (D5)	CS (5)

Radio to FPGA

Net Name	Radio Pin	FPGA Pin
NRF_FPGA_GPIO_1	P0.19 (F3)	IOT_170 (A12)
NRF_FPGA_GPIO_2	P0.17 (G3)	IOT_172 (C12)

Radio to IMU

Net Name	Source	Destination
FLEX_A_MISO	P0.13 (G4)	SA0/SDO (4)
FLEX_A_SCLK	P0.14 (H5)	SCL/SPC (2)
FLEX_A_MOSI	P0.12 (H6)	SDA/SDI (3)

Schematic Symbols (recommended)

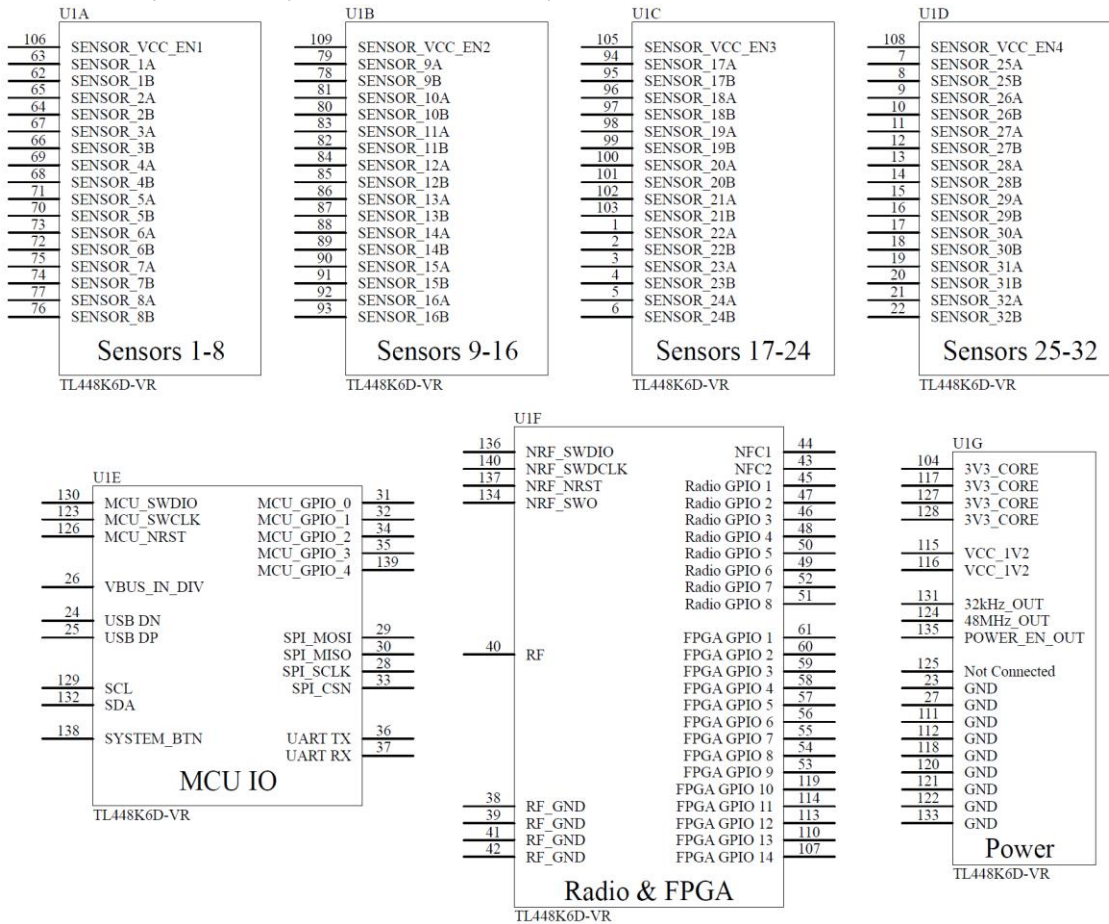

Sensor Connections (recommended)

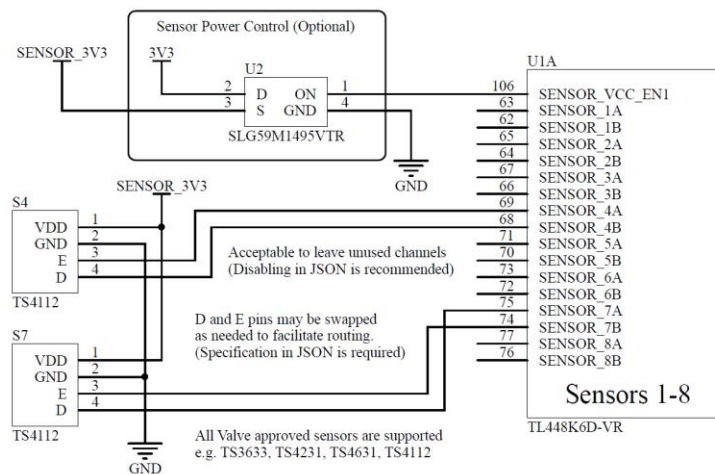

For Wireless Tracked devices, only Sensor Channels 1 through 26 are enabled

All 32 sensors may be used for USB Devices

MCU Connections

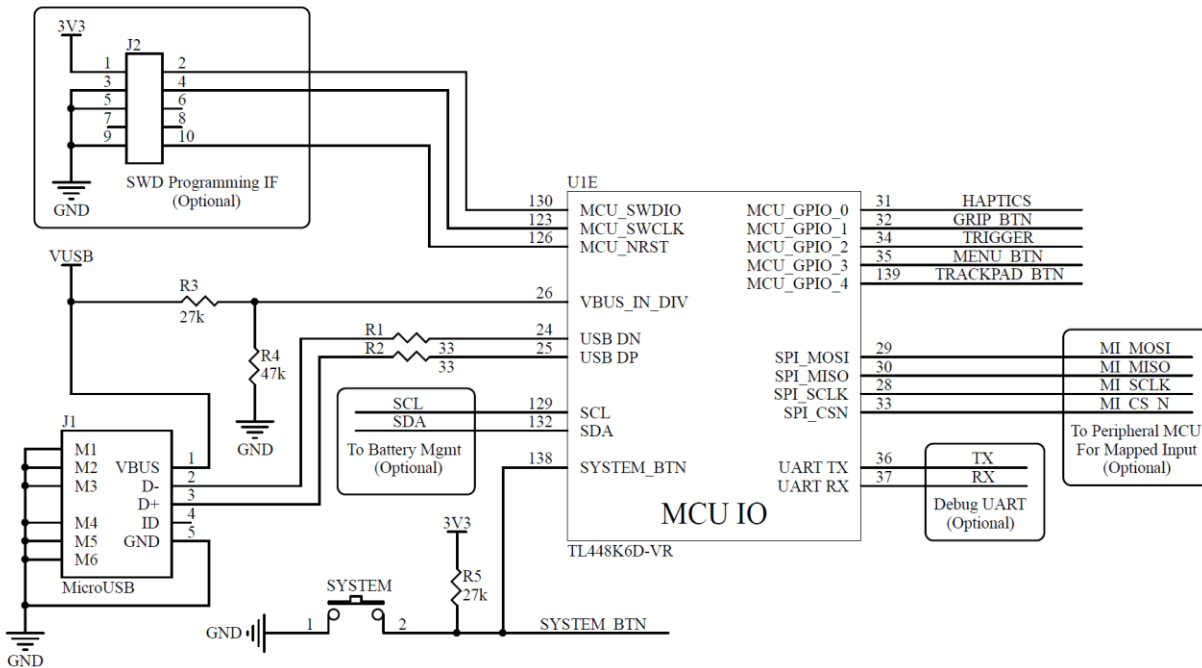

Radio & FPGA IO Connections

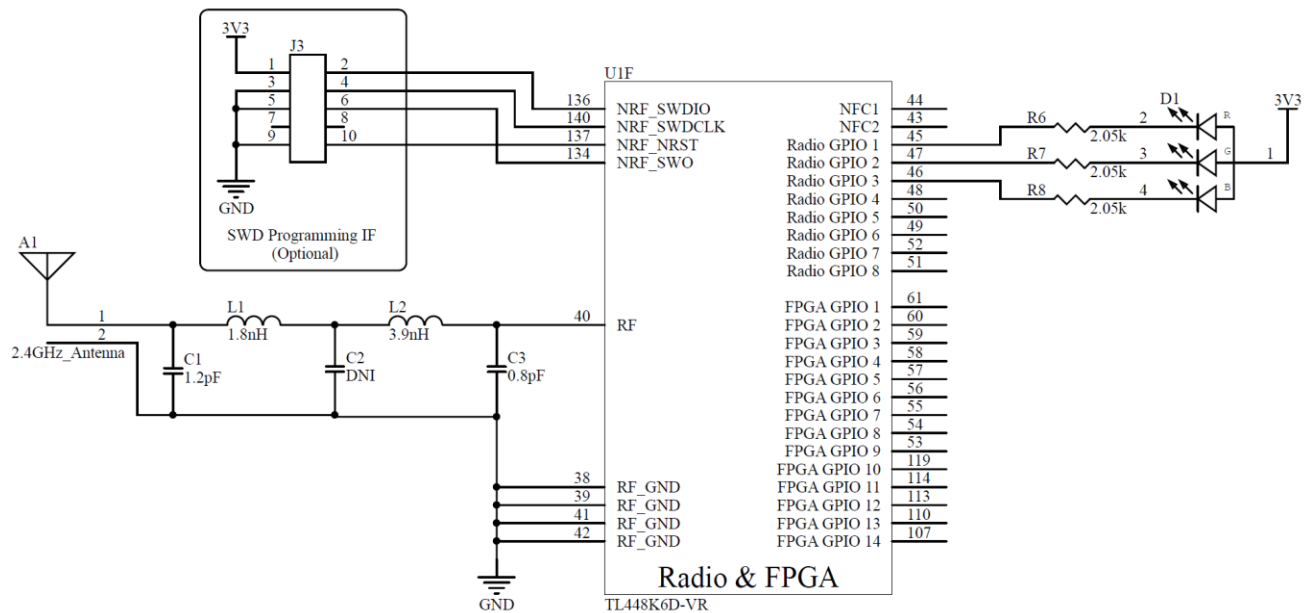

Power Supply & Battery Management Connections

The TL448K6D-VR Module supports multiple Power supply configurations, each one is targeted at a different application with different tradeoffs of cost, battery support, efficiency and speed of charging.

USB Powered Only

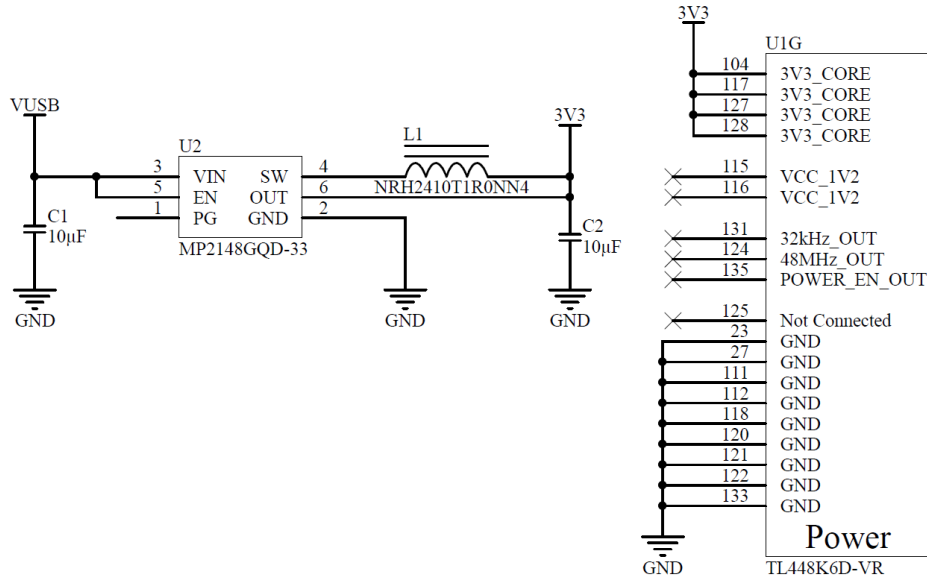

Low Cost – Linear Battery Charger

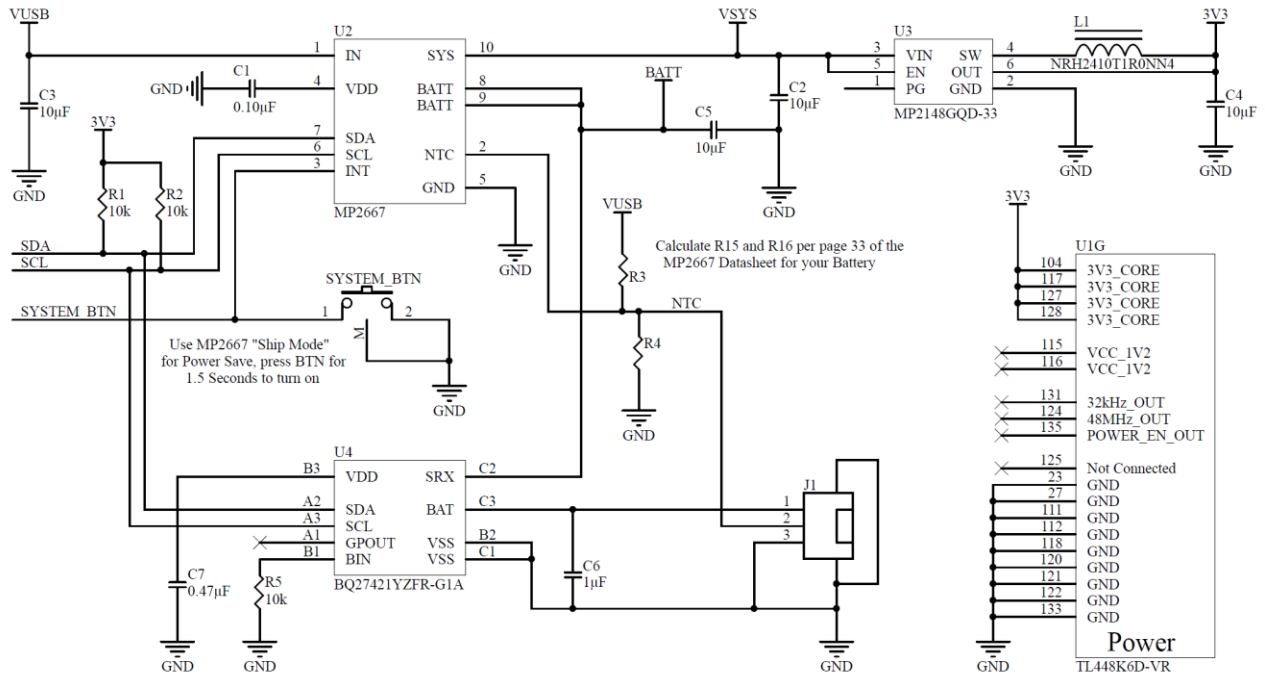

High Efficiency, Fast charging

(Refer to SteamVR HDK Documentation 602-100862_sch_evm_application_board schematic)

Mechanical Details

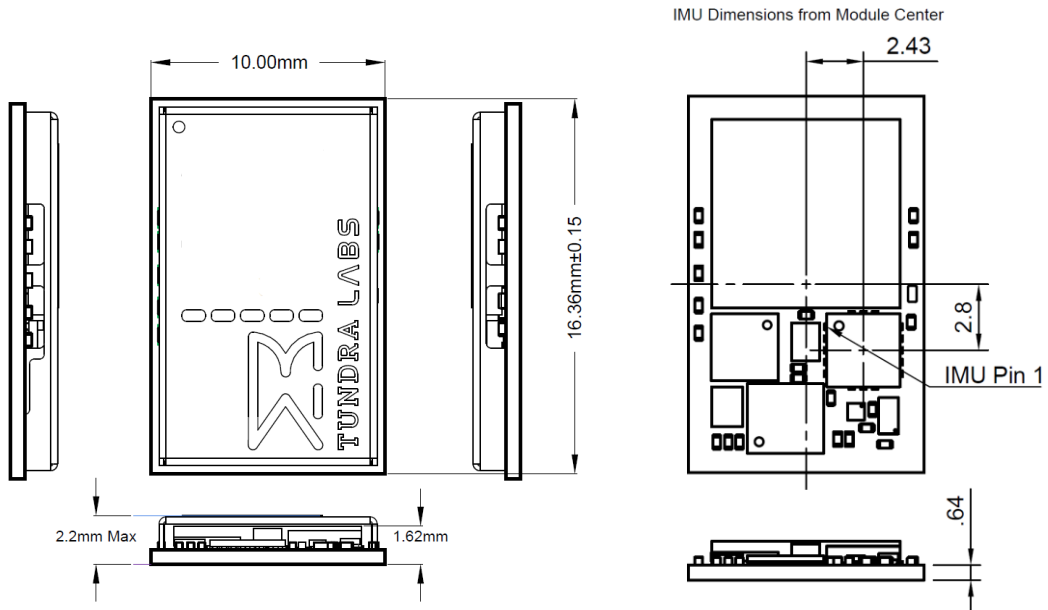

Footprint

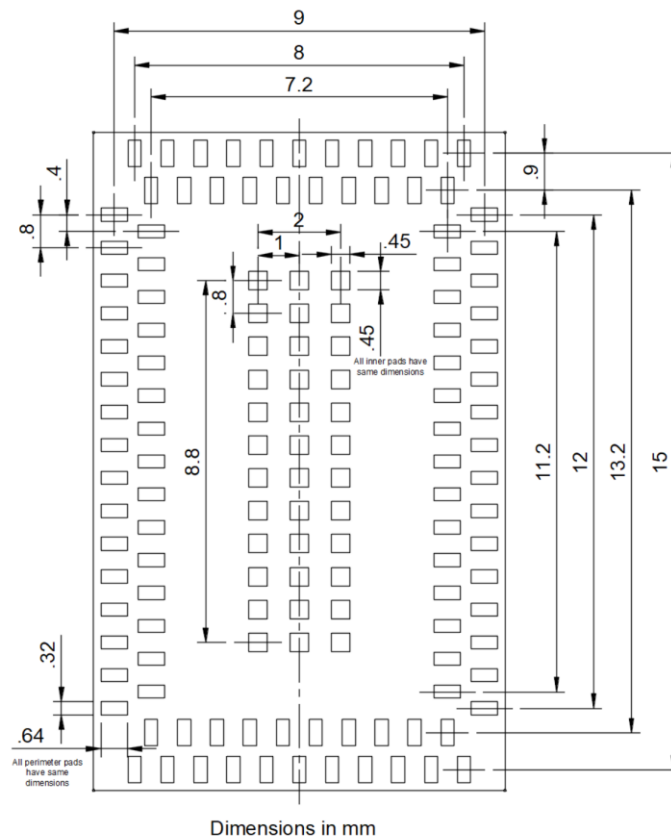

Legal

Tundra Labs LLC reserves the right to make corrections, enhancements, improvements and other changes to its products and services and to discontinue any product or service. Buyers should obtain the latest relevant information before placing orders and should verify that such information is current and complete.

All products (also referred to herein as “components”) are sold subject to Tundra Labs Standard Terms and Conditions of Sale supplied at the time of order acknowledgment.

Testing and other quality control techniques are used to the extent Tundra Labs deems necessary. Except where mandated by applicable law, testing of all parameters of each component is not necessarily performed. Tundra Labs assumes no liability for applications assistance or the design of Buyers’ products. Buyers are responsible for their products and applications using this component. To minimize the risks associated with Buyers’ products and applications, Buyers should provide adequate design and operating safeguards. Tundra Labs does not warrant or represent that any license, either express or implied, is granted under any patent right, copyright, or other intellectual property right relating to any combination, machine, or process in which this component is used.

Information published by Tundra Labs regarding third-party products or services does not constitute a license to use such products or services or a warranty or endorsement thereof. Use of such information may require a license from a third party under the patents or other intellectual property of the third party, or a license from Tundra Labs under the patents or other intellectual property of Tundra Labs.

Tundra Labs is not responsible or liable for altered documentation. Information of third parties may be subject to additional restrictions. Resale of this component with statements different from or beyond the parameters stated by Tundra Labs herein for this component voids all express and any implied warranties for this Tundra Labs component and is an unfair and deceptive business practice.

Tundra Labs is not responsible or liable for any such statements. Buyer acknowledges and agrees that it is solely responsible for compliance with all legal, regulatory and safety-related requirements concerning this product, and any use of this component in its applications, notwithstanding any applications-related information or support that may be provided by Tundra Labs.

Buyer represents and agrees that it has all the necessary expertise to create and implement safeguards which anticipate dangerous consequences of failures, monitor failures and their consequences, lessen the likelihood of failures that might cause harm and take appropriate remedial actions. Buyer acknowledges and agrees that this component was not designed for, or intended for use in, safety-critical, FDA Class III (or similar life-critical medical equipment), automotive or military/aerospace applications. Buyer’s use of this component in any of the above-mentioned applications is done solely at the Buyer’s risk and Buyer will fully indemnify Tundra Labs and its representatives against any damages arising out of the use this component in these or any other applications in which this component was not specifically developed for use.

No rights are granted to use of the SteamVR™ Tracking system. Those rights are only available from Valve Corporation.
<http://steamvr.com/tracking>.

Tundra Labs LLC
1025 Lombardi Ave
Green Bay, WI 54304
tundra-labs.com