

## Vyper Industrial Fan Assembly Instructions

1. **Stand Assembly:** Insert the three legs into the triangular leg bracket and fasten using the six of the M6 hex head bolts.

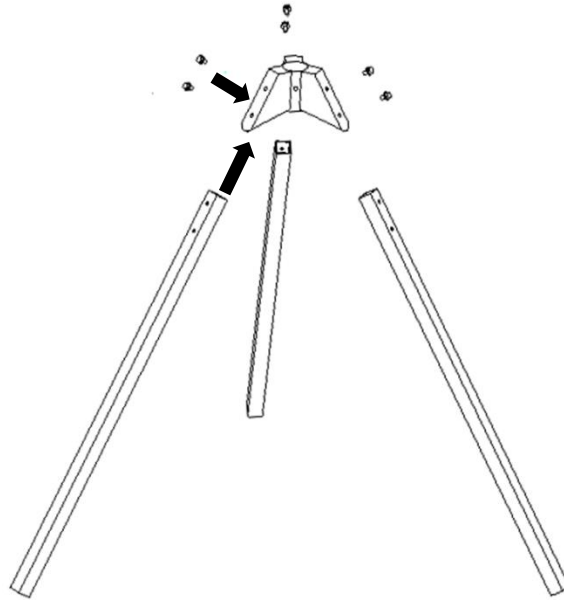

2. **Motor Assembly:** Screw the threaded hand knob into the triangular leg bracket, do not tighten. Insert the tube of the motor assembly into the triangular leg bracket and tighten the hand knob to the desired height. **HAND KNOB MUST BE TIGHT BEFORE OPERATION.**

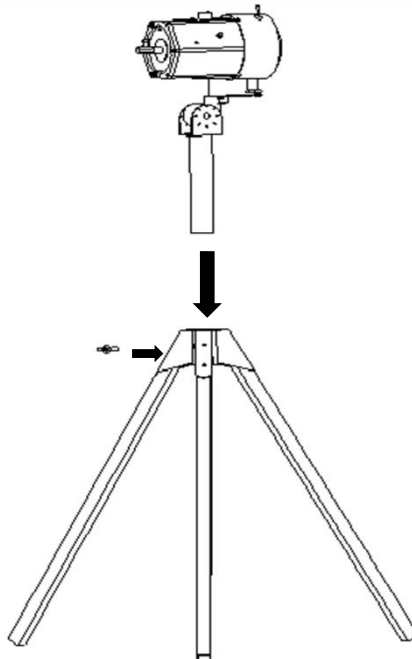

- 3. Rear Mesh Guard:** Some fans may come with this step already done. Place the rear mesh guard over the front of the motor and align with the holes. Attach using (4) M8 cross head screws and tighten.

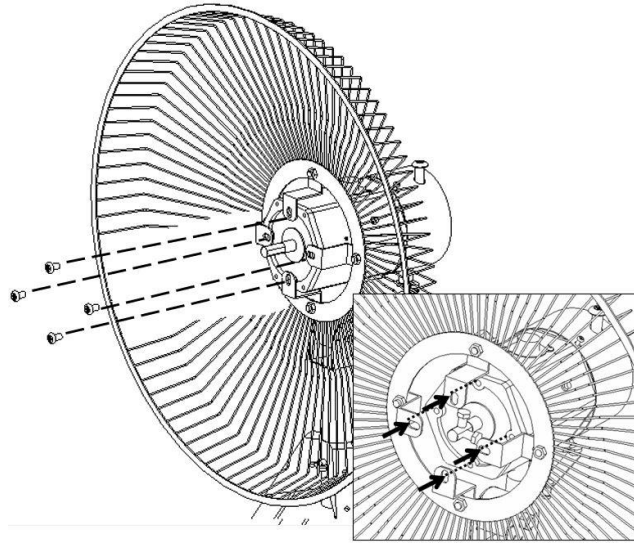

- 4. Fan Blade Install:** Slide the fan blade assembly onto the motor shaft with the long part of the hub towards the motor. Lock the fan blade assembly onto the shaft using (2) of the M8 cross head screws and tighten.  
**NOTE:** One of the screws must be tightened onto the flat surface of the motor shaft!

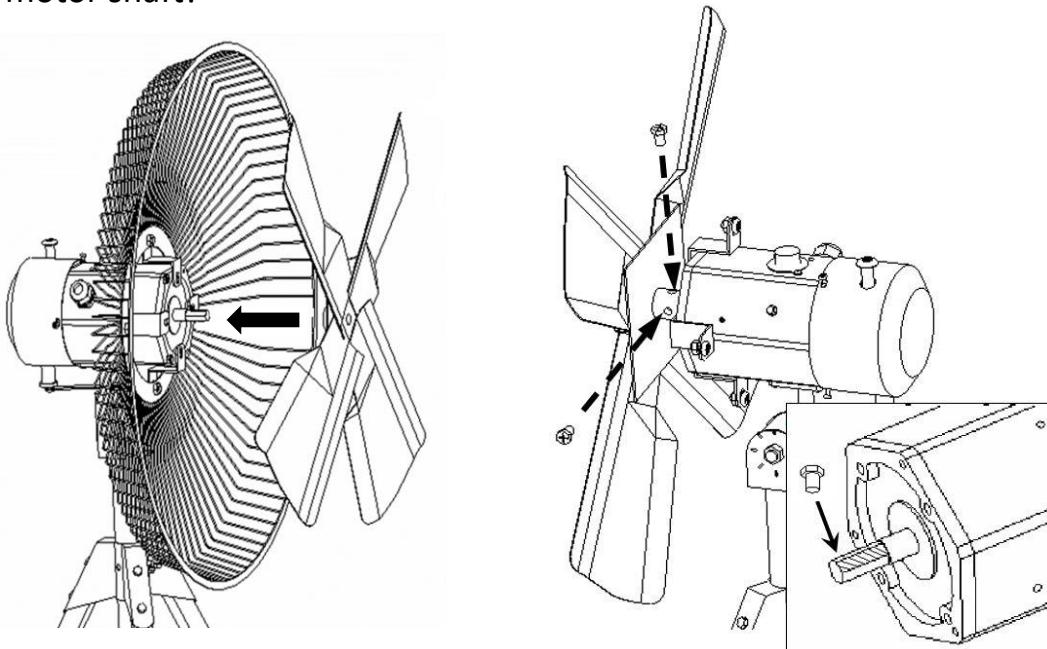

5. **Front Mesh Guard:** Attach the front mesh guard so the fixed top tab connects in between the mesh of the rear guard. Connect the (5) buckle tabs tightly around the perimeter of the guard.

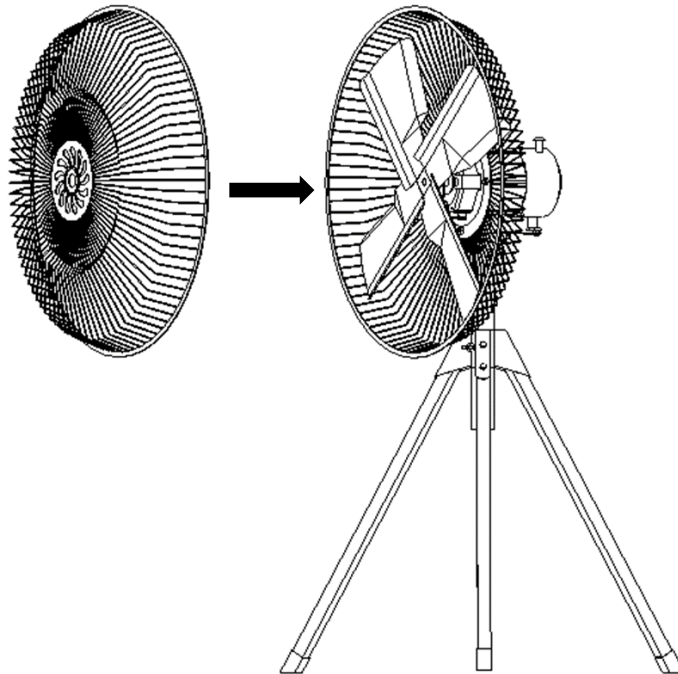

6. **Operation:** Keep fan on flat and level surface. Be sure the speed knob is set to 0 before plugging into power. Solid green light indicates speed knob control.

**Natural Wind Feature:** This feature varies the motor speed from 600-1,200rpm to replicate natural wind. The speed knob will not work with this feature activated, note the flashing green light.

**Oscillating Feature:** Controlled by the knob towards the back of the motor. Push down to activate side to side feature. Pull up for fixed position. Faster the air speed, faster the oscillating.

## Wall Mount Instructions

- 1. Mount Wall Bracket (concrete walls):** Determine the best spot for the fan location keeping in mind that the power source should be close. Place the bracket in the position you want it to be mounted and mark the holes. The bracket should be mounted vertically and not on an angle. Drill the holes to .3125" and insert the four M8 expansion screws. Attach the plate and secure with the (4) hex nuts. Note the out and upward orientation of the tube on the bracket.

**Drywall Mounting:** Determine the best spot for the fan location keeping in mind that the power source should be close. Locate a vertical wall stud behind the drywall. **THE FAN MUST BE MOUNTED TO A WALL STUD!** Place the bracket in the desired location and mark the holes. The bracket should be mounted vertically and not on an angle. Note the out and upward orientation of the tube on the bracket. We recommend using (2) 5/16" wood lag bolts for attaching to the wall stud and (2) 1/4" drywall toggle bolts for attaching to the drywall.

**NOTE:** Vyper Industrial is not liable for damage or injury due to improper wall mounting! Wall mounting is done at your own risk!

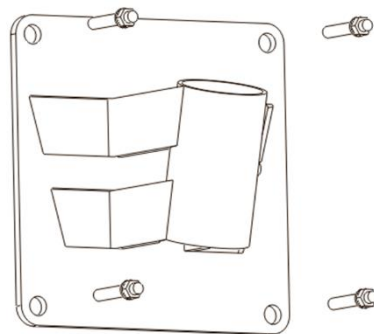

2. Screw the threaded hand knob into the wall mount bracket, do not tighten. Insert the tube of the motor assembly into the bracket and tighten the hand knob to the desired height. **HAND KNOB MUST BE TIGHT BEFORE OPERATION.**

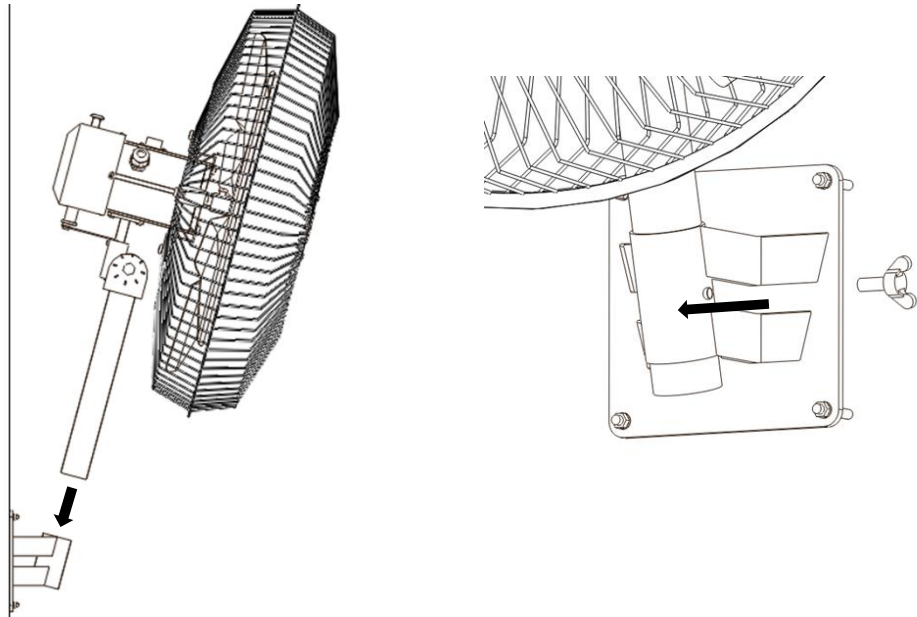

## **Precautions**

1. During maintenance, cleaning and disassembly, in order to prevent danger, disconnect the fan from power source.
2. Do not flush the motor and switch directly with water.
3. Do not use volatile solvents (such as gasoline, kerosene, alcohol, degreased oil...) chemical rags, acid-base soapy water, polished powder... etc., to clean fan.
4. When the fan is in operation, do not insert body parts, foreign objects, etc. to avoid injury.
5. If the power cord is damaged, it must be replaced by professionals of the factory to avoid further damage or injury.
6. If the fan is faulty, please do not disassemble the relevant parts without authorization to avoid further damage or injury.
7. Please purchase original corresponding parts to avoid poor precision in assembly and affect operation quality.
8. Place fan on a flat, level, stable surface during operation. Failure could result in poor center of gravity resulting in damage or injury.
9. The fan cannot be used without the correct installation of the fan blade guards to avoid damage or injury.
10. Vyper Industrial is not liable for injury, damage, or warranty due to natural disasters, man-made deliberate destruction, or improper installation and/or assembly.