



Brio®

AQUUS

**Tankless 1.5:1 RO Filtration
System with Smart Faucet
Setup Manual**

Model No.: TROE600COL

Table of Contents

Safety Information	3
Intended Use	4
Product Features	4
Indicator Panel Description	5
Product Dimensions	5
Materials Needed	5
Specifications	5
Package Contents	6
Installation	7
Installation Overview	7
Connect to the Cold Water Supply	7
Make the Reverse Osmosis Waste Connections	9
Install the Faucet	10
Complete the Installation	11
Operation	11
Start Up the Filtration System	11
Start Water Purification	11
Shut Down	11
Care and Maintenance	12
Filter Replacement Schedule	12
Replacing the Filter	12
Flushing the Filters	12
Troubleshooting	13
Warranty	14

Safety Information

WARNING: To reduce risk of injury and property damage, you must read this entire guide before assembling, installing, and operating the filtration system.

- If the power cable is damaged, do not use. Contact Customer Service for a replacement.
- Avoid storing in an area exposed to intense sunlight as this can cause damage to components.
- Do not store in or expose the device to temperatures lower than 32°F (0°C). The ideal temperature range is 39 - 100°F (4 - 38°C).
- The device must be installed or relocated by a professional technician due to the risk of electric shock and product damage.
- The best working pressure for this device ranges from 14.5 to 58 PSI. Install a pressure increasing or decreasing device if the water pressure is lower or higher than this level.
- For use with municipal tap water only. Not for use with well or underground water.
- Do not place magnetic devices near the device as damage could occur.
- Do not place heavy objects on the device.
- Do not allow children near the device without adult supervision.
- To unplug the unit, grasp the power cord by the plug and pull directly from socket. Do not plug in or unplug with wet hands.
- Do not place combustible substances near the device. Keep away from heat sources and open flames.
- Install this device near a floor drain.
- If the device is not going to be used for a long period of time, shut off power and close the shut-off valve. When restoring the water supply, first open all faucets to drain any remaining sediment, then open the shut-off valve.

Intended Use

This appliance system is intended to be used in household and similar applications such as:

- Staff kitchen areas in shops, offices, and other working environments
- Farm houses
- Hotels, motels, and other bed-and-breakfast-type environments
- Residential-type environments
- Catering and similar non-retail applications.

This appliance is not intended for use by persons (including children) with reduced physical, sensory, or mental capabilities, or lack of experience and knowledge, unless they are given supervision or instruction concerning the use of appliance by a person responsible for their safety.

Product Features

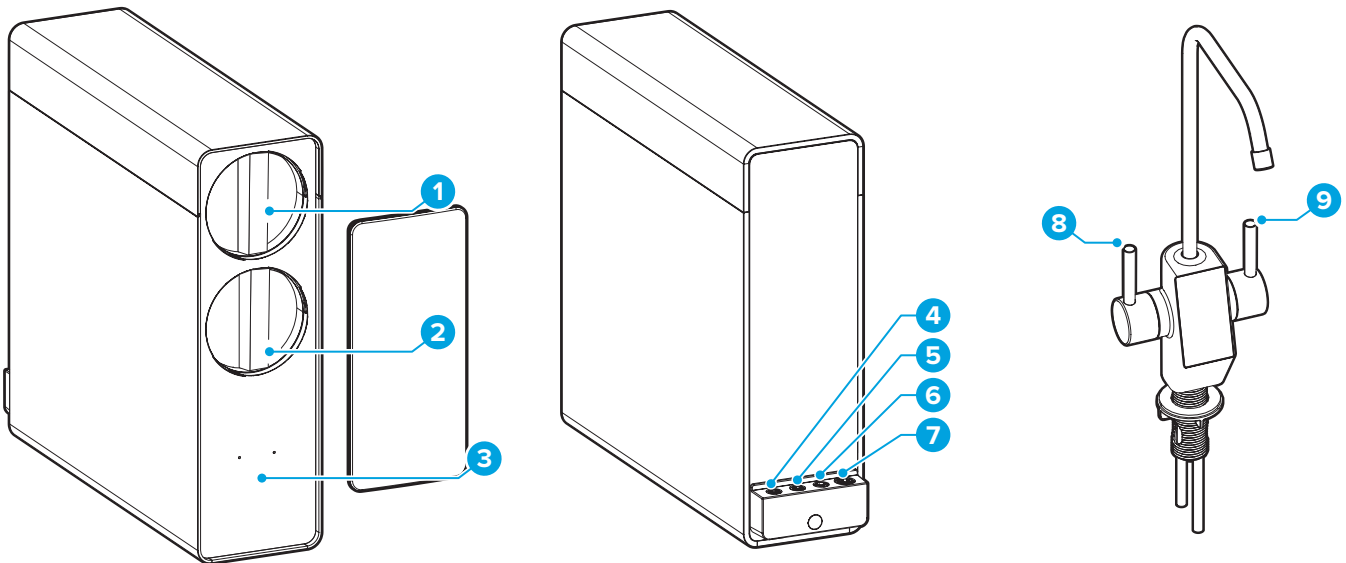

Part	Description
1	Reverse osmosis filter compartment
2	PCB filter compartment
3	Display panel
4	Waste water connection
5	RO filtered water connection

Part	Description
6	Filtered water connection
7	Inlet water connection
8	Filtered water handle
9	RO filtered water handle

Indicator Panel Description

10. Filter indicator lights – When blinking, indicate it is time to change filters (RO or PCB).
11. Reset button – Press to reset the system after changing filters.
12. Flush button – Press to flush newly installed filters.

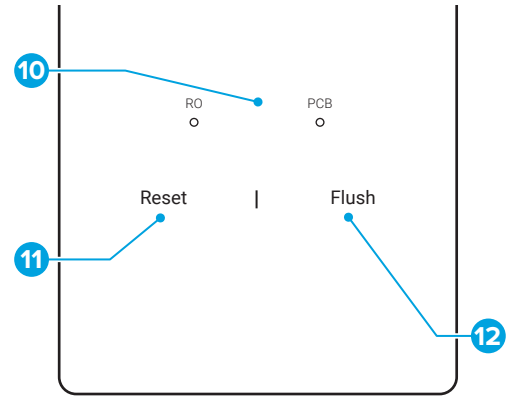

Product Dimensions

Height	Width	Depth
16.6 in. (42.1 cm)	5.2 in. (13.2 cm)	18.2 in. (46.1 cm)

Materials Needed

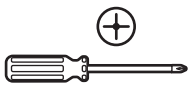

Phillips-Head
Screwdriver



Adjustable Wrench

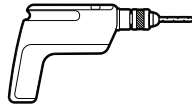

Power Drill



1/4" Drill Bit (for
Drain Saddle)



1" Drill Bit
(for Faucet Hole)

Specifications

Gallons per day	600
Purified flow rate	1.5 L/min
Recovery rate	1.5:1
Filtration system	PCB and RO

Package Contents

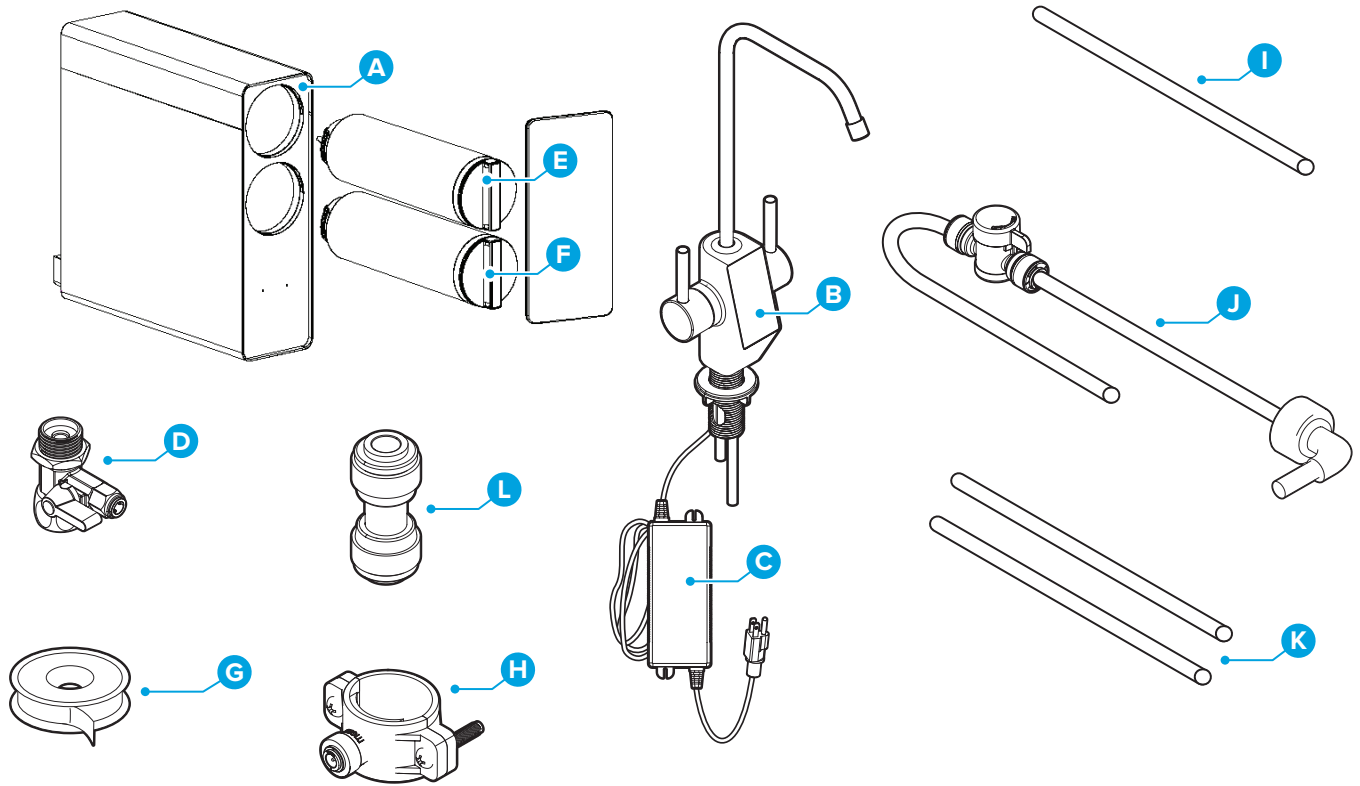

Part	Description	Quantity
A	RO filtration unit	1
B	Smart faucet	1
C	Power adapter	1
D	Feed water adapter	1
E	RO filter	1
F	PCB filter	1

Part	Description	Quantity
G	Plumbers tape	1
H	Drain saddle	1
I	RO waste water tube	1
J	Shut-off valve tube	1
K	Faucet tubing	2
L	1/4 in. Quick connector	2

Installation

1. Installation Overview

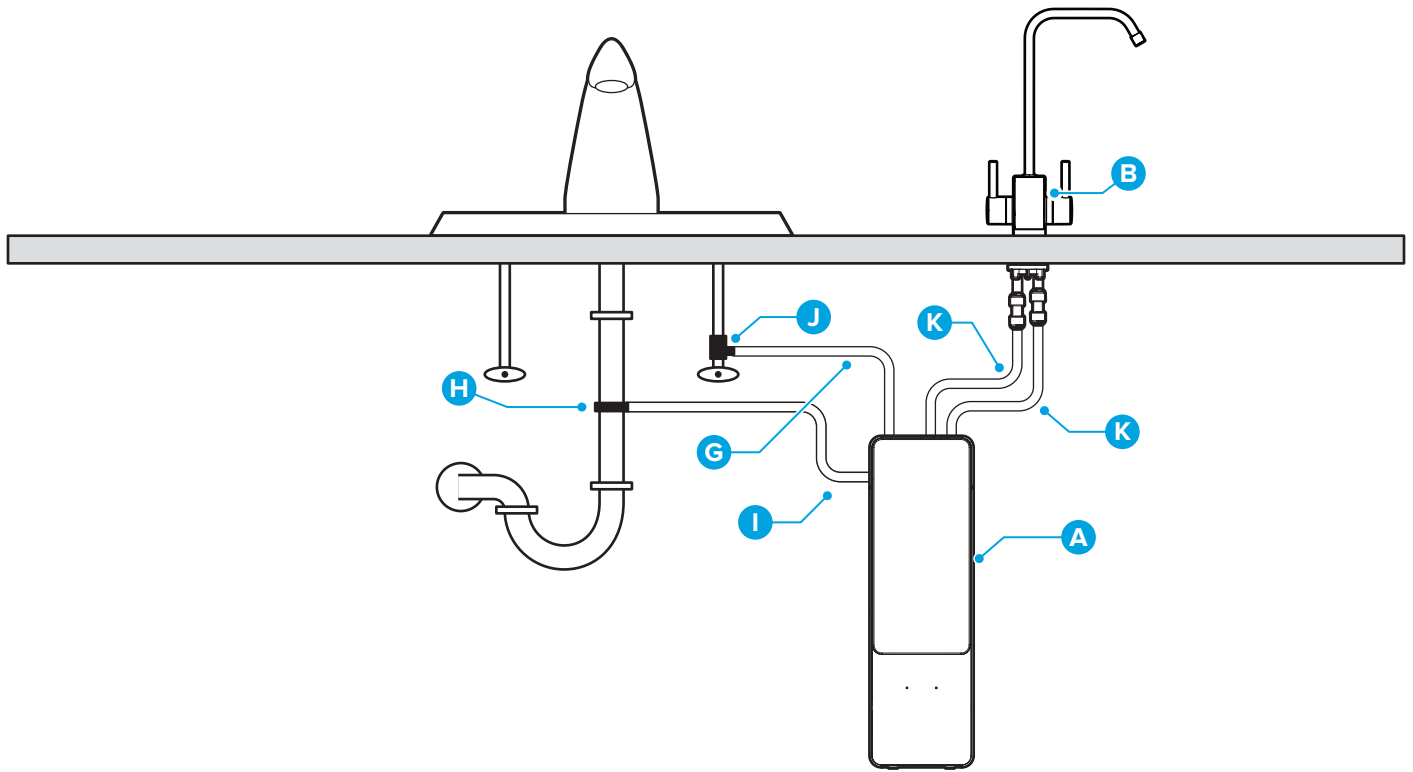

2. Connect to the Cold Water Supply

CAUTION: DO NOT CONNECT THIS WATER LINE TO A HOT WATER SUPPLY LINE. The water supply to the unit MUST be from the COLD WATER LINE. Using HOT WATER will severely damage your filters.

- A. Turn off and then disconnect the current cold water supply line.
- B. Connect the feed water adapter (D) to the cold water supply line.
- C. Connect the cold water supply line on top of the feed water adapter (D).

NOTE: An extra adapter nut is included on top of the feed water adapter (D) to attach to a 3/8 in. or 1/2 in. feed plumbing line.

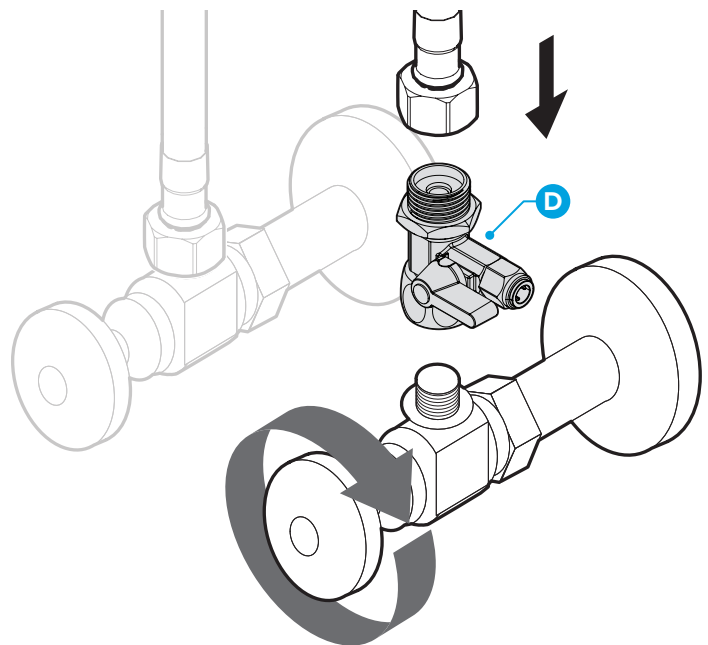

- D. Insert the shut-off valve with tube (J) straight into the quick connector piece of the feed water adapter (D).
- E. Tighten the nut on the feed water adapter.

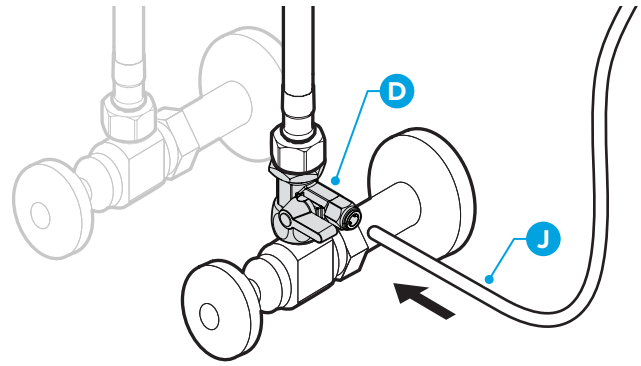

- F. Gently tug on the tube (J) to ensure a secure connection with the feed water adapter (D).

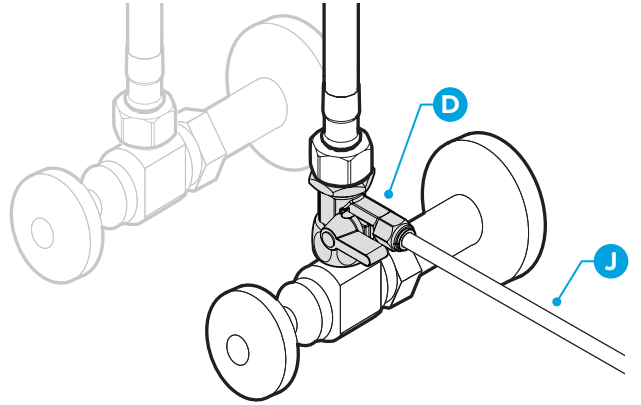

3. Make the Reverse Osmosis Waste Connections

The “RO” filter assembly requires a drain line connection to be installed, which removes rejected water to the sewer. The drain saddle connects the drain line from the dispenser to your drain pipe. The drain saddle is designed to fit around a standard 1.5 in. OD (outer diameter) drain pipe.

- ✓ Always install the drain saddle BEFORE the P-trap (15). Ensure the drain saddle is in place on a vertical or horizontal section of the pipe.
- ✗ To avoid clogging the drain line with debris, do not install the drain saddle on a section of piping that is located after the drain pipe meets a garbage disposal or dishwasher drain.

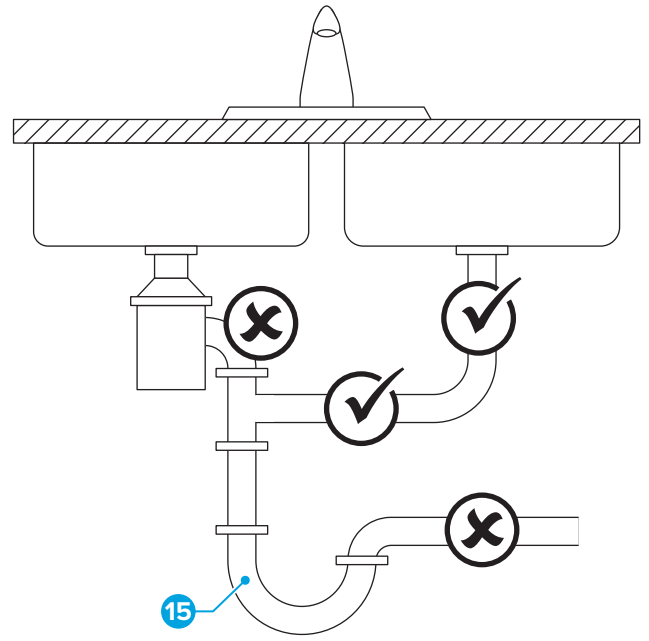

To make the Reverse Osmosis (RO) drain connections:

- A. Determine the location for your drain saddle (H) and then make a mark on the drain pipe for the opening (16).
- B. Use your drill and a 1/4 in. drill bit to create a hole at the mark, ensuring you only drill through one side of the drain pipe.
- C. Find the half of the drain saddle (H) with the hole in the center, remove the backing from the foam gasket, align the gasket with the hole on the drain saddle (H), and stick the adhesive side of the gasket to the drain saddle (H).
- D. Position both halves of the drain saddle (H) on the drain pipe with the saddle's opening aligned over the drilled hole, and insert your drill bit through the saddle (H) and drilled hole to ensure proper alignment.
- E. Secure both ends of the drain saddle (H) together using the bolts and nuts, but do not overtighten.
- F. Connect the RO waste water tube (I) to the drain saddle (H).

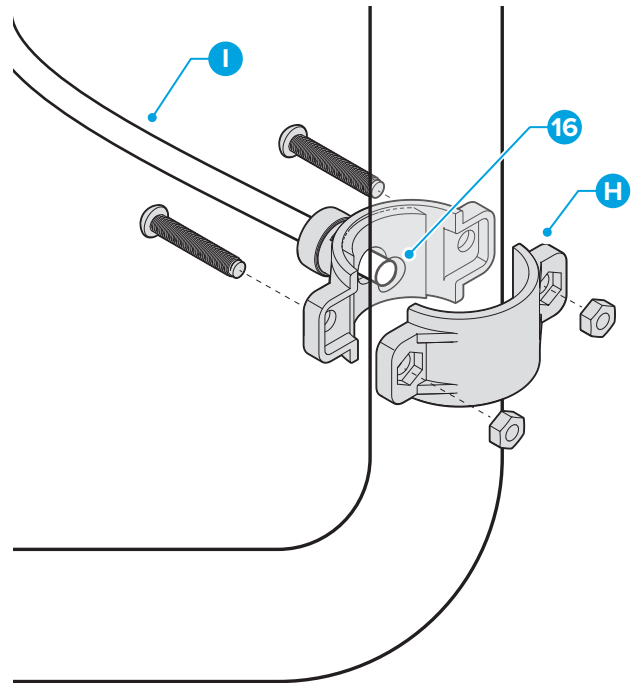

4. Install the Faucet

- A. Ensure that you have a mounting hole in your sink or countertop for this faucet. If you do not, create a mounting hole no less than 1.0 - 1.2 in. (2.54 - 3.0 cm),
- B. Remove the washer (17) and lock nut (18) from the faucet. Ensure that you leave the O-ring (19) on the faucet (B).
- C. Attach one 1/4 in. quick connector (L) to the long stem outlet (filtered water) and other 1/4 in. quick connector to the short stem outlet (RO filtered water).

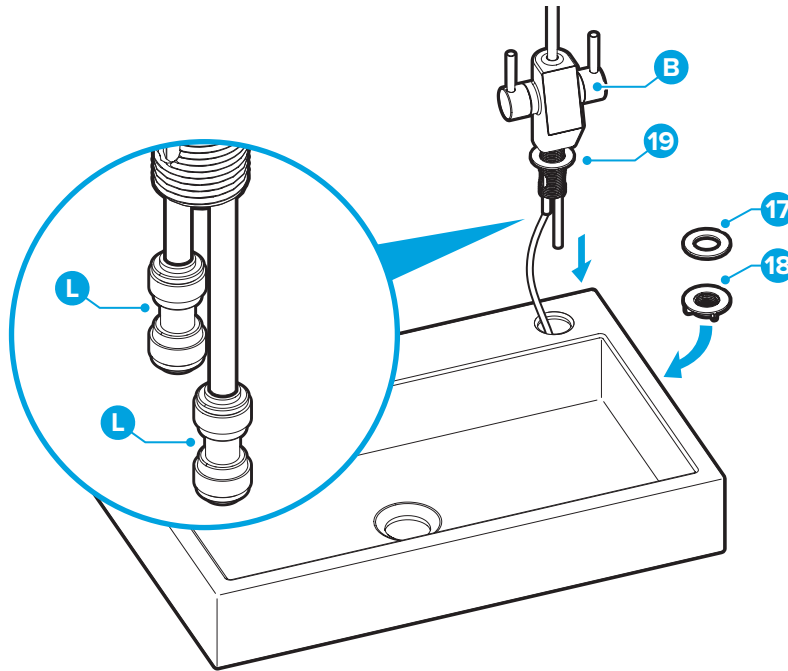

- D. Insert the faucet into the mounting hole and secure in place underneath the sink with washer (17) and lock nut (18).
- E. From underneath the sink, insert each faucet tube (K) 0.6 in. (1.5 cm) into each of the 1/4 in. quick connectors (L).

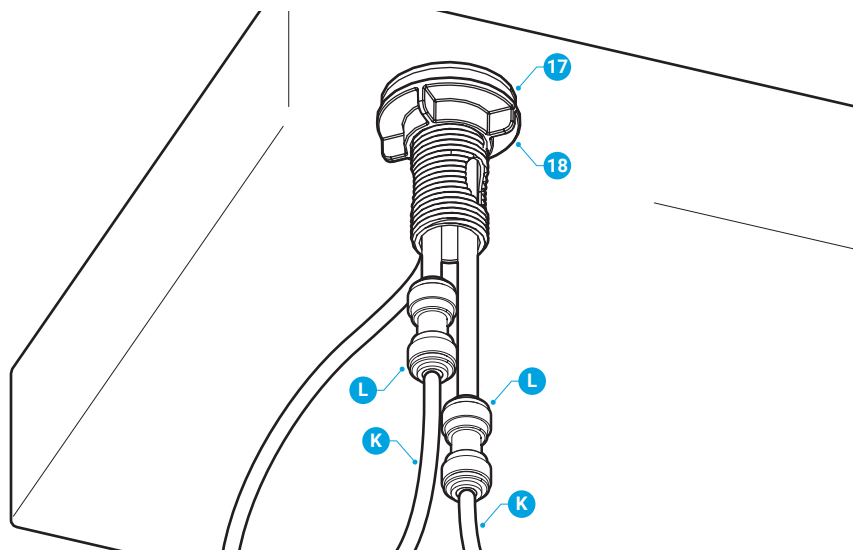

5. Complete the Installation

- A. Connect the shut-off valve tube (J) to the inlet water connection (1).
- B. Connect the RO water tube (K) to the RO water connection (2).
- C. Connect the filtered water tube (K) to the filtered water connection (3).
- D. Connect the RO waste water tube (I) to the waste water connection (4).
- E. Ensure all connections are secure before proceeding.

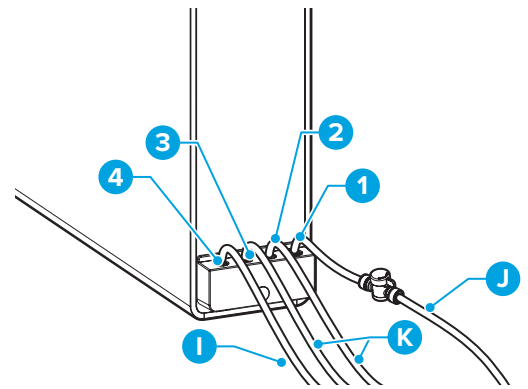

Operation

Start Up the Filtration System

1. Ensure all water connections are completed as described in the Installation section.
2. Turn the cold water supply on. Open the shut-off valve on tube (J). Connect the power supply to the filtration system and then to an outlet. The filter indicator panel turns on.

NOTE: When the system is first turned on it goes into automatic flushing state, which lasts approximately 90 seconds.

3. Open the RO lever on the smart faucet and allow RO water to run for 5-6 minutes, or until water runs clear. Do not drink this water. While system is flushing, make sure there are no leaks in the joints, fittings, valves and tubing connections.

Start Water Purification

Open the faucet and the water filtration system starts to produce water.

NOTE: If the faucet runs water for a long time (for 2 hours), the filtration unit enters overtime protection mode. The display screen flashes, and the system is no longer able to produce water. Unplug the filtration unit, then plug it in again to clear the protection mode.

Shut Down

1. Close the shut-off valve on the tube (J).
2. Unplug the power supply.

Care and Maintenance

- Keep this device in a cool, dry place away from direct sunshine.
- Use a clean, soft cloth to remove dust build-up. Do not use soap, detergent, or harsh abrasives.
- If the filtration system is not going to be used for an extended period of time, close the shut-off valve on tube (J) and unplug the unit.
- Never lay the unit on its side or back. It should always be operated and stored in an upright position.
- If the cold water inlet temperature drops to 32 °F (0 °C), there is a risk the tubes could crack and damaging leaking could occur. To prevent this, turn off the shut-off valve on the tube (J), then open the handles of the smart faucet and drain any remaining water out of the filtration system.

Filter Replacement Schedule

Filter Type	Replacement Schedule	Function
PCB Composite Filter (PAC and Carbon)	12 months	Removes mud, sand, rust, suspended materials, residual chlorine, and abnormal flavor from water.
RO Filter	24 months	Removes up to 99% of contaminants including arsenic, lead, fluoride, heavy metals, and more.

Replacing the Filter

When one or both of your filter indicator lights begin to flash, or the smart faucet's filter life indicator displays 0, the filter(s) needs to be replaced. To change filter:

1. Unplug unit from power source, then disconnect from water supply. Carefully pry off front filter compartment cover.
2. Grasp handle of expired filter and rotate counterclockwise to unlock filter from compartment. Remove expired filter.
3. Insert new filter, rotating clockwise to lock it into place. Snap filter cover back onto unit.
4. Restore water connection, then plug unit back into power source. Press and hold Reset button until the filter indicator light stops flashing (approximately 3 seconds). Proceed to "Flushing the Filters" section.

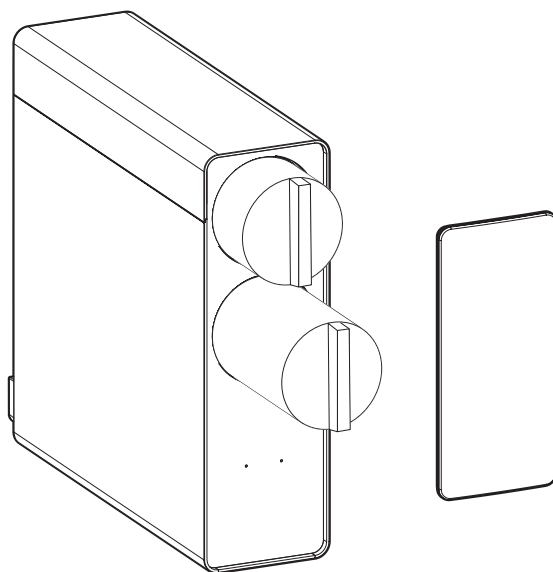

Flushing the Filters

Always flush new filters before using. Open the faucets. Press the Flush button once. The flushing process takes approximately 60 seconds. To stop the flushing process at any time, press the Flush button again.

NOTE: The Flush button does not work when the device is in an automatic flushing state.

Troubleshooting

Problem	Probable Cause	Solution
The filters are generating a light noise during operation.	The filters will generate a light noise during operation.	This is normal.
The water output volume has dropped.	<ul style="list-style-type: none"> • The filter is jammed. • The filter needs to be replaced. • The shut-off valve is not in the ON position. • The ambient temperature is low. 	<ul style="list-style-type: none"> • Flush or replace the filter. • Replace the filter. • Check the shut-off valve and the faucet to ensure they are in the ON position. • When the ambient temperature is low, it is normal for the RO-filtered water flow to drop. Increase ambient temperature.
The water quality is low.	<ul style="list-style-type: none"> • A filter needs to be replaced. • The filtration system has not been used in more than 3 days. • The quality of the source water is low. 	<ul style="list-style-type: none"> • Replace one or both filters. • Turn the faucets on and flush for 3-5 minutes. • Confirm the water source is municipal tap water.
There is a water leak.	A component is damaged.	Immediately turn off the power and water, and contact customer service for assistance.
There is no water output after replacing a filter.	There is an air jam.	When replacing a filter, first unplug the unit. Then shut off the water supply. Replace the filter. Turn the water supply back on, then plug the unit back in.

Warranty

Brio (“Vendor”) warrants to the original purchaser of the Brio Water Filtration System (the “Product”), and to no other person, that if the Product is assembled and operated in accordance with the printed instructions accompanying it, then for a period of one (1) year from the date of purchase, all parts in the Product shall be free from defects in material and workmanship. This Limited Warranty shall be limited to repair or replacement of parts, which prove defective under normal use and service and which Vendor shall determine in its reasonable discretion upon examination to be defective. To take advantage of this Limited Warranty, please follow these steps:

1. Please retain your sales slip or invoice, as Vendor may require reasonable proof of your date of purchase.
2. Contact Vendor’s Customer Service Department using the contact information listed below.
3. Return parts to Vendor, per Vendor’s instructions, at your cost and expense.
4. Upon receipt by Vendor, Vendor shall advise you in writing whether a defect covered by this Limited Warranty exists in any returned part and whether your claim has been approved or denied.
5. Upon Vendor’s approval of your claim, Vendor will replace such defective part without charge to you.

WHAT THIS LIMITED WARRANTY DOES NOT COVER: This Limited Warranty does not cover any failures or operating difficulties of the Product due to accident, abuse, misuse, alteration, misapplication, improper installation or improper maintenance or service by you or any third party, or failure to perform normal and routine maintenance on the Product, as set out in the User’s Manual. In addition, this Limited Warranty does not cover damages to the finish, such as scratches, dents, discoloration or rust after purchase.

This Limited Warranty is the only express warranty given on the Product and is in lieu of all other express warranties. Vendor disclaims all warranties for products that are purchased from seller other than authorized retailers or distributors. THIS LIMITED WARRANTY RESTRICTS THE DURATION OF ANY AND ALL IMPLIED WARRANTIES, INCLUDING WITHOUT LIMITATION, THE IMPLIED WARRANTY OF MERCHANTABILITY AND FITNESS FOR A PARTICULAR PURPOSE TO THE ONE (1) YEAR TERM OF THIS LIMITED WARRANTY. UPON THE EXPIRATION OF THE ONE (1) YEAR TERM OF THIS LIMITED WARRANTY, VENDOR DISCLAIMS ANY AND ALL IMPLIED WARRANTIES, INCLUDING WITHOUT LIMITATION THE IMPLIED WARRANTIES OF MERCHANTABILITY AND FITNESS FOR A PARTICULAR PURPOSE, THE PRODUCT BEING THUS SOLD AS-IS, WITH ALL FAULTS. FURTHER, VENDOR SHALL HAVE NO LIABILITY WHATSOEVER TO PURCHASER OR ANY THIRD PARTY FOR ANY SPECIAL, INDIRECT, PUNITIVE, INCIDENTAL, OR CONSEQUENTIAL DAMAGES. OTHER THAN THIS LIMITED WARRANTY, THERE ARE NO WARRANTIES WHICH EXTEND BEYOND THE DESCRIPTION ON THE FACE HEREOF. Vendor assumes no responsibility for any defects caused by third parties. This Limited Warranty gives you specific legal rights, and you may have other rights which vary from state to state. State law may also override statements in this Limited Warranty regarding the restriction on the duration of implied warranties. Some jurisdictions do not allow exclusion or limitation of special, incidental or consequential damages, or limitations on how long a warranty lasts, so the above exclusion and limitations may not apply to you.

Brio[®]

Contact Us

Call: +1 844-257-4103