

Brio®

G10-U

Tankless 2:1 RO Filtration System
Setup Manual

Model No.: ROSL500



Table of Contents

Safety Information	3
Intended Use	4
Product Features	4
Indicator Panel Description	5
Product Dimensions	5
Materials Needed	5
Specifications	5
Package Contents	6
Installation	6
Installation Overview	6
Connect to the Cold Water Supply	7
Make the Reverse Osmosis Waste Connections	8
Install the faucet	9
Complete the Installation	10
Operation	10
Start Up the Filtration System	10
Start Water Purification	10
Shut Down	10
Troubleshooting	11
Care and Maintenance	11
Filter Replacement Schedule	12
Replace the Filters	12
Flushing the Filters	12
Warranty	13

Safety Information

WARNING: To reduce risk of injury and property damage, you must read this entire guide before assembling, installing, and operating this filtration system.

- If the power cable is damaged, do not use. Contact Customer Service for a replacement.
- Avoid storing in an area exposed to intense sunlight as this can cause damage to components.
- Do not store or expose the device in temperatures lower than 32°F (0°C). The ideal temperature range is 39°F - 100°F (4-38°C).
- The device must be installed or relocated by a professional technician due to the risk of electric shock and product damage.
- The best working pressure of this device ranges from 0.1 to 0.4MPa. Install a pressure increasing or decreasing device if the water pressure is lower or higher than this level.
- For use with municipal tap water only. Not for use with well or underground water.
- Do not place magnetic devices near the device as damage could occur.
- Do not place heavy objects on the device.
- Do not allow children near the device without adult supervision.
- When cutting off the power supply, do not pull the power cord as this could cause damage.
- Do not place combustible substances near the device. Keep away from heat sources and open flames.
- Install this device near a floor drain.
- If the device is not used for long periods of time, shut off power and turn off the 3-way ball valve.

Intended Use

This appliance is intended to be used in household and similar applications such as:

- Staff kitchen areas in shops, offices, and other working environments
- Farm houses
- Clients in hotels, motels, and other residential type environments
- Bed and breakfast type environments
- Catering and similar non-retail applications

This appliance is not intended for use by persons (including children) with reduced physical, sensory, or mental capabilities, or lack of experience and knowledge, unless they have been given supervision or instruction concerning use of the appliance by a person responsible for their safety.

Product Features

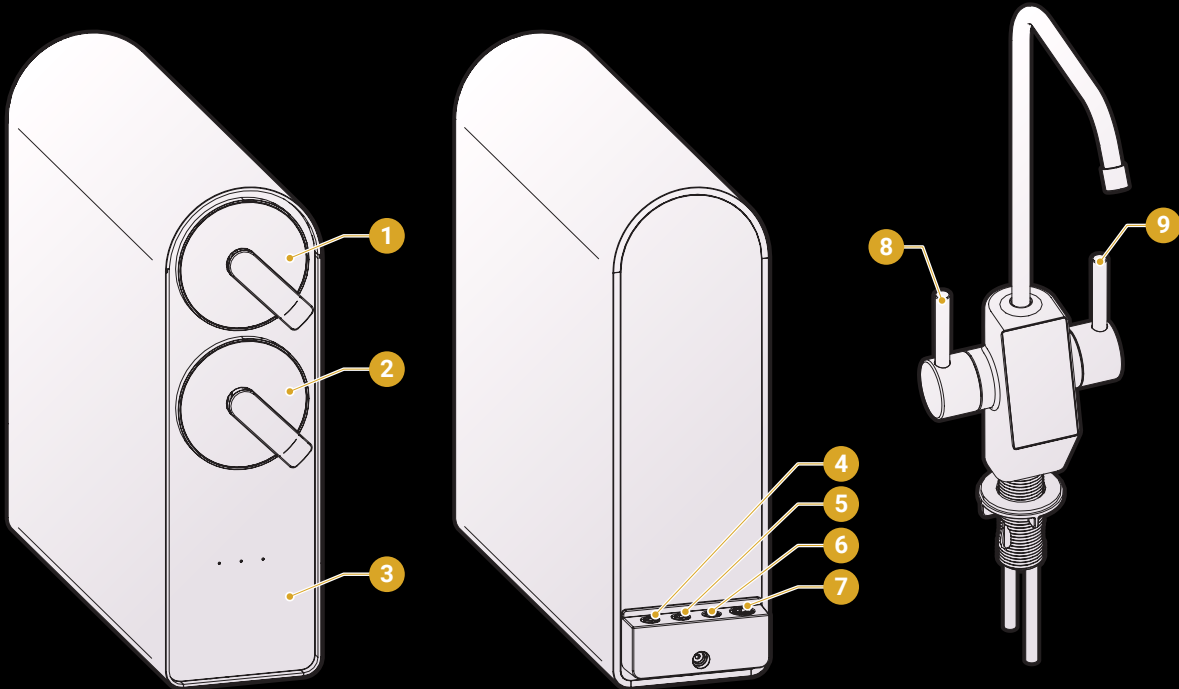

Part	Description
1	Reverse Osmosis filter compartment
2	PCB filter compartment
3	Display panel
4	Waste water connection
5	Purified water connection

Part	Description
6	Filtered water connection
7	Inlet water connection
8	Tap water handle
9	Filtered water handle

Indicator Panel Description

1. Filter indicator lights – When blinking, indicates it is time to change filters (RO or PCB).
2. Reset button – Press to reset the system after changing filters.
3. Flush button – Press to flush newly installed filters.

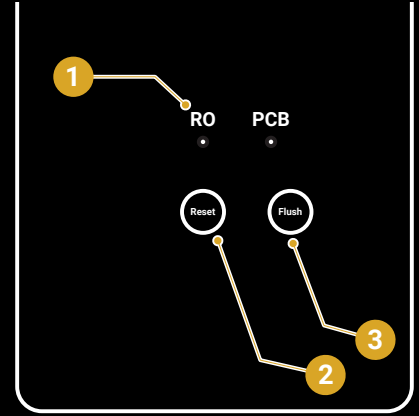

Product Dimensions

Height	Width	Depth
42 cm (16.5 in.)	13.2 cm (5.2 in.)	46.1 cm (18.2 in.)

Materials Needed



Wrench

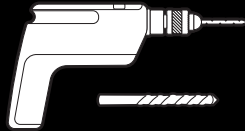

Electric drill with 1/4 in. drill bit

Specifications

RO Water Output	7200L
Active Carbon Water Output	4000L
Rated Voltage/Frequency	24 V~/50/60Hz
Rated Total Power	80W
Purified Water Flow Rate / RO Water Output	1.75L/min
Water Inlet Pressure	0.1-0.4MPa
Critical Pressure	3.2MPa

Package Contents

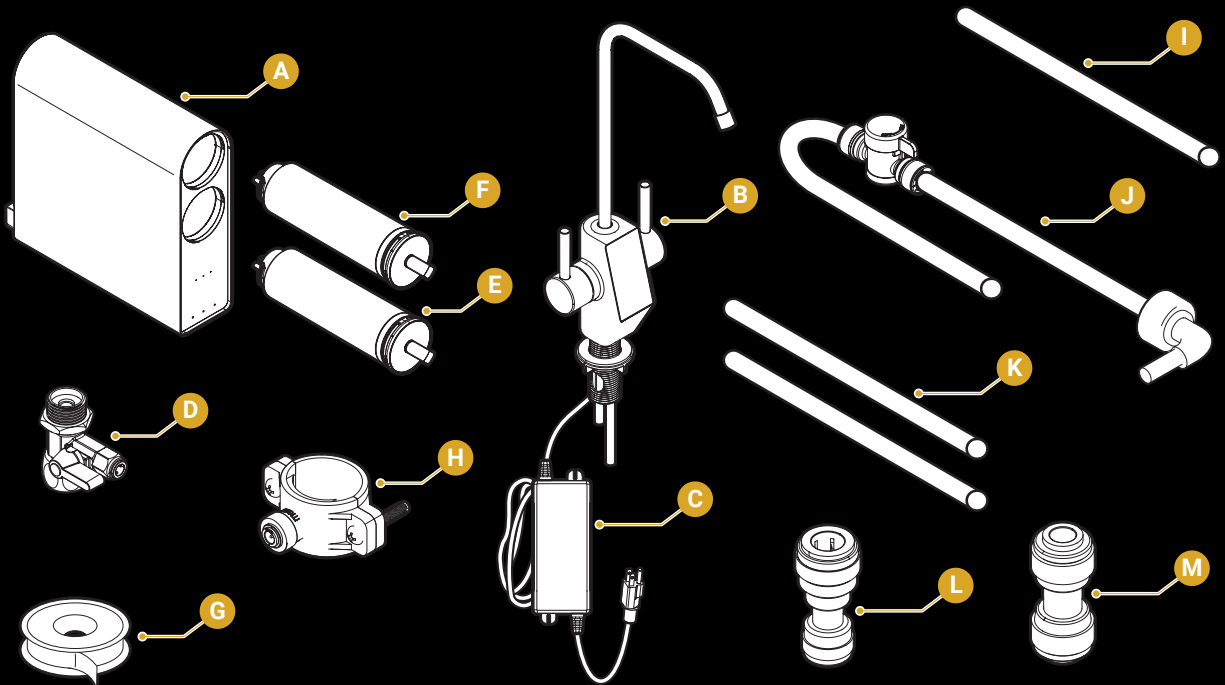

Part	Description	Quantity
A	RO filtration system	1
B	Faucet	1
C	Power adapter	1
D	Feed water adapter	1
E	PCB filter	1
F	RO filter	1
G	Plumbers tape	1

Part	Description	Quantity
H	Drain saddle	1
I	RO water outlet tube	1
J	Shut-off valve tube	1
K	Faucet tubing	2
L	2/8 - 3/8 in.Quick connect	1
M	2/8 in. Quick connect	2

Installation

1. Installation Overview

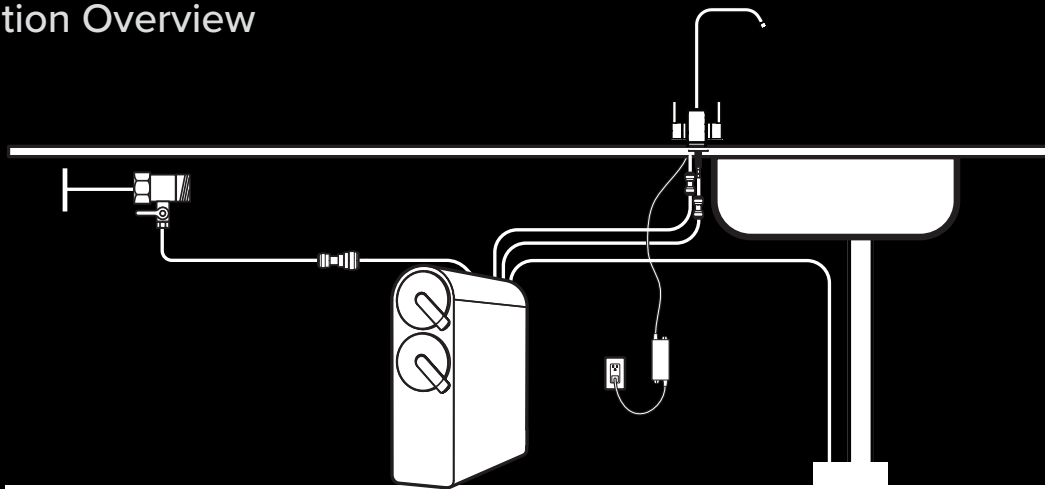

2. Connect to the Cold Water Supply

CAUTION: DO NOT CONNECT THIS WATER LINE TO A HOT WATER SUPPLY LINE. The water supply to the unit MUST be from the COLD WATER LINE. Using HOT WATER will severely damage your filters.

- D. Turn off and then disconnect the current cold water supply line.
- E. Connect the feed water adapter (D) to the cold water supply line.
- F. Connect the cold water supply line on top of the feed water adapter (D).

NOTE: An extra adapter nut is included on top of the feed water adapter (D) to attach to a 3/8 in. or 1/2 in. feed plumbing line.

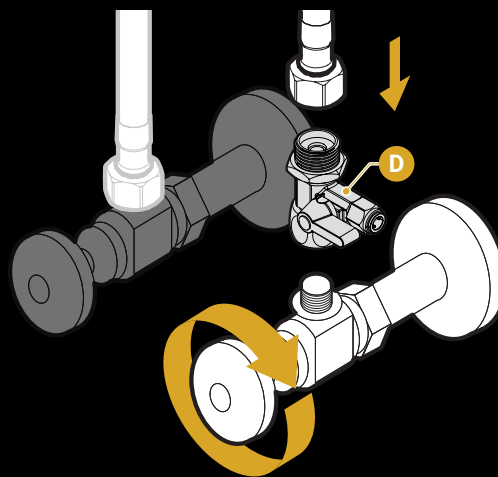

- G. Insert the shut-off valve with tube (J) straight into the quick connector piece of the feed water adapter (D).

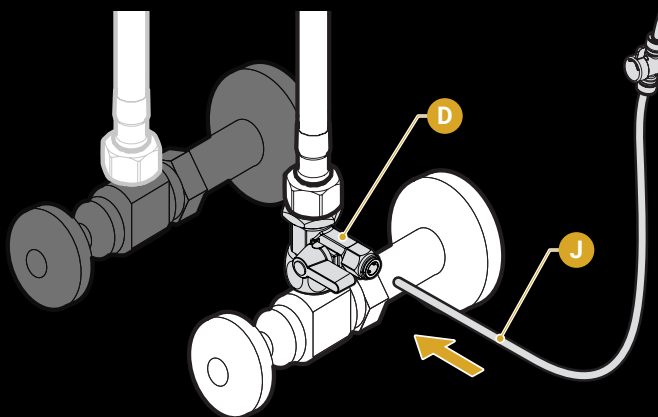

- H. Gently tug on the tube (J) to ensure a secure connection with the feed water adapter (D).

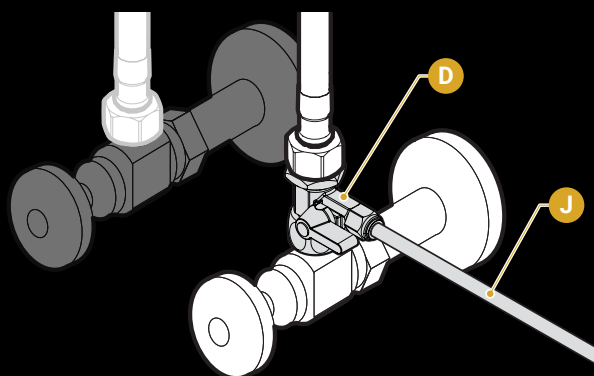

3. Make the Reverse Osmosis Waste Connections

The “RO” filter assembly requires a drain line connection to be installed, which removes rejected water to the sewer. The drain saddle connects the drain line from the dispenser to your drain pipe. The drain saddle is designed to fit around a standard 1.5 in. OD (outer diameter) drain pipe.

- ✓ Always install the drain saddle before the P-trap and on a straight vertical or horizontal section of the pipe.
- ✗ To avoid clogging the drain line with debris, do not install the drain saddle after the drain pipe meets a garbage disposal or dishwasher drain.

To make the Reverse Osmosis (RO) drain connections:

- A. Determine the location for your drain saddle (H) and then make a mark on the drain pipe for the opening (1).
- B. Use your drill and a 1/4 in. drill bit to drill a hole at the mark, ensuring you only drill through one side of the drain pipe.
- C. Find the half of the drain saddle (H) with the hole in the center, remove the backing from the foam gasket, align the gasket with the hole on the drain saddle (H), and stick the adhesive side of the gasket to the drain saddle (H).
- D. Position both halves of the drain saddle (H) on the drain pipe with the saddle's opening aligned over the drilled hole, and insert your drill bit through the saddle (H) and drilled hole to ensure proper alignment.
- E. Secure both ends of the drain saddle (H) together using the bolts and nuts, but do not over-tighten.
- F. Connect the RO water outlet tube (I) to the drain saddle (H).

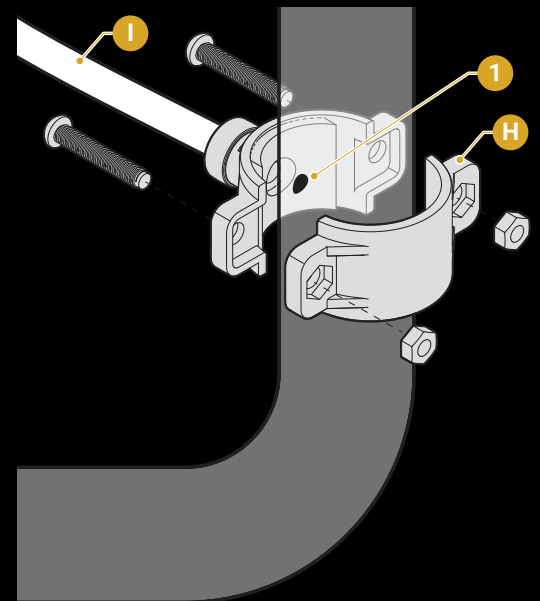
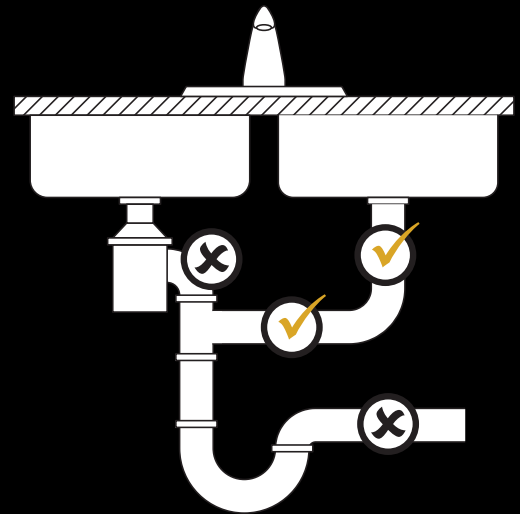

4. Install the faucet

IMPORTANT: If your sink does not have a second faucet hole, please contact a licensed professional to create one. Do NOT attempt to drill a faucet hole yourself as this may damage the sink.

- A. Ensure that you have a faucet mounting hole in your sink or sink countertop for this faucet. If you do not, create a mounting hole no less than 1 – 1.2 in. (26 – 30 mm).
- B. Remove the washer (1) and lock nut (2) from the faucet. Ensure that you leave the O-ring (3) on the faucet.
- C. Attach the two 2/8 in. quick connects (M) to the large faucet post (filtered water) and the short faucet post (tap water).

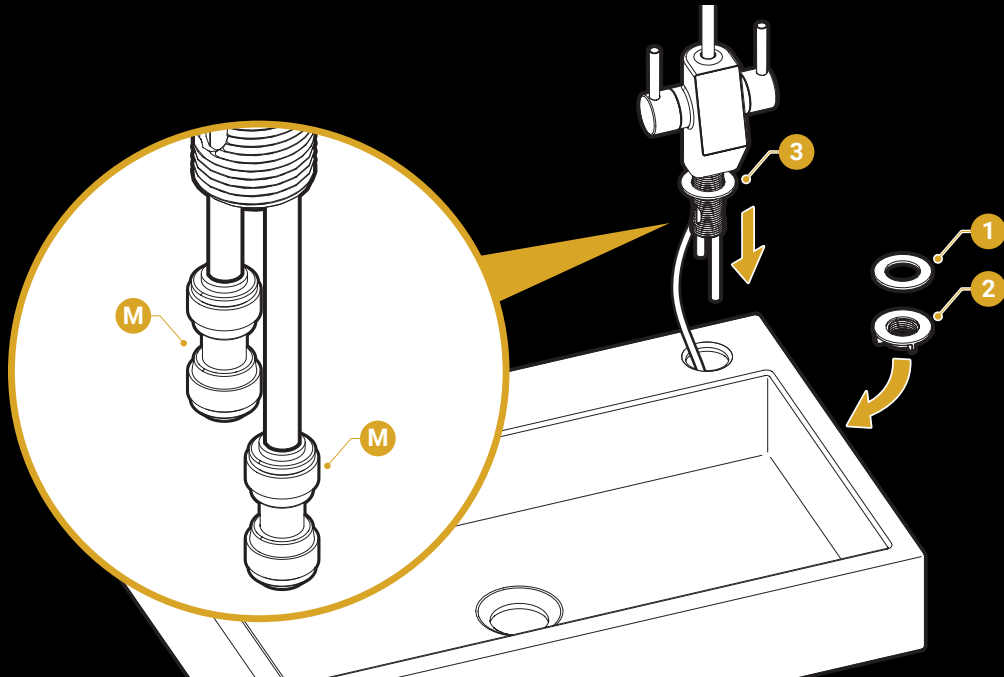

- D. Place the faucet into the mounting hole and secure in place underneath the sink with the washer (1) and lock nut (2).
- E. Connect two faucet tubings (K) to each of the 2/8 in. quick connects (M) underneath the sink.

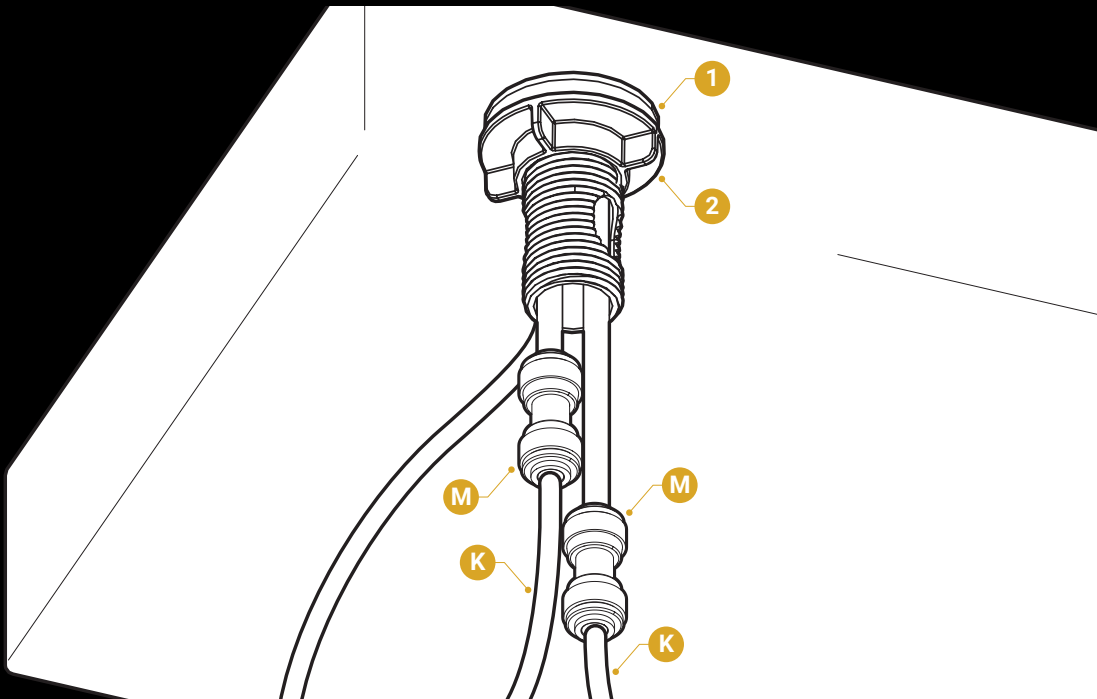

5. Complete the Installation

- A. Connect the shut off valve tube (J) to the inlet water connection (1).
- B. Connect the faucet tubing (K) connected to the 2/8 in. quick connect (M) to the filtered water connection (2).
- C. Connect the faucet tubing (K) connected to the 2/8 in. quick connect (M) to the purified water connection (3).
- D. Connect the RO water outlet tube (I) to the waste water connection (4).
- E. Ensure all connections are made, and proceed to the Operation section for starting for first time, plugging in, and flushing.

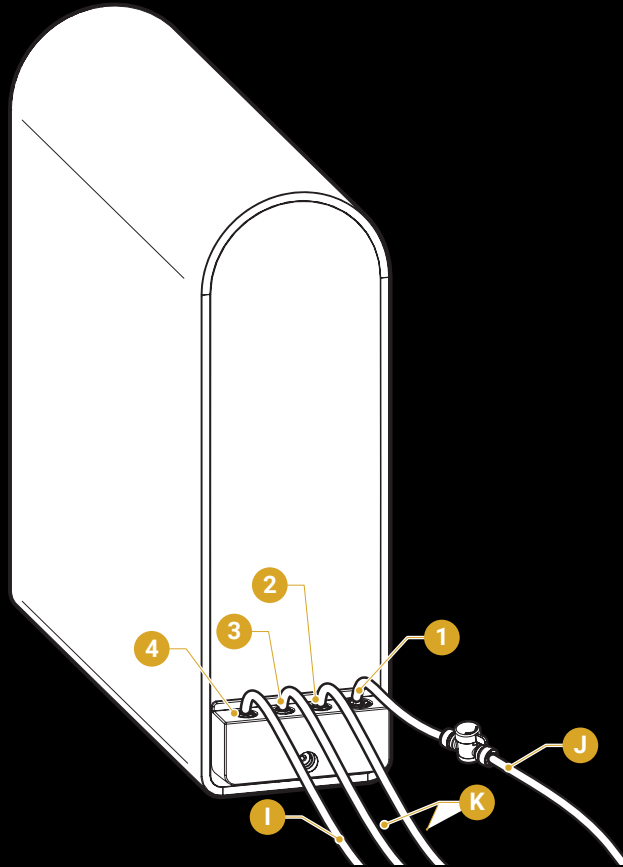

Operation

Start Up the Filtration System

1. Ensure all water connections are completed as described in the Installation section.
2. Connect the power supply to the filtration system and then to an outlet.

The filter indicator panel turns on.

Start Water Purification

Open the faucet and the water purifier starts to produce water.

NOTE: If the faucet runs water for a long time (for 2 hours), the water purifier enters overtime protection mode. The display screen at the side of the machine flashes, and the device is no longer able to produce water. Unplug the power plug until the indicator turns off. Plug the device in again to clear the protection mode.

Shut Down

1. Close the shut-off valve on the tube (J).
2. Unplug the power supply.

Troubleshooting

Problem	Probable cause	Solution
The filter is generating a light noise during operation.	The filter can generate a light noise during operation.	This is normal.
The water output volume has dropped.	<ul style="list-style-type: none"> The filter is jammed. The filter needs to be replaced. The ball valve or faucet is not completely turned on. 	<ul style="list-style-type: none"> Flush or replace the filter. Replace the filter. Check the water inlet ball valve, or the faucet to ensure they are turned on completely.
The water quality is low.	<ul style="list-style-type: none"> The filter needs to be replaced. The device was not used for a long period of time (over 3 days). The quality of the source water is low. 	<ul style="list-style-type: none"> Replace the filter. Turn on and flush the faucet for 3-5 minutes. Confirm that the water source is municipal tap water.
There is water leakage.	A component is damaged.	Cut off the water and power supply.
There is no water output after replacing a filter.	There is an air jam.	When replacing a filter, shut off the power supply, followed by the water supply. Then replace the filter, the water supply, and power supply in that order.

Care and Maintenance

- Keep this device in a dry and cool place and avoid direct sunshine.
- Use a clean, soft cloth to remove dust build-up. Do not use soap, detergent, or harsh abrasives.
- Before going out for an extended period of time, ensure the power and valve are off.
- Do not position the product in a declining, horizontal, or upturned position.
- When the water inlet temperature is as low as 32°F (0°C), turn off the water inlet valve and drain the water in the water purifier to prevent cracks.

Filter Replacement Schedule

Filter Type	Replacement Schedule	Function
PCB Composite Filter (PAC and Carbon)	12 months	Removes mud, sand, rust, suspended materials, residual chlorine, and abnormal flavor from water.
RO Filter	24 months	Removes up to 99% of contaminants including arsenic, lead, fluoride, heavy metals and more.

Replace the Filters

When the filter indicator light on the indicator panel flashes, it indicates that one of your filters needs to be replaced.

1. Disconnect the water and power supply, and find the filter that needs to be replaced.
2. Rotate the filter rotary cover counterclockwise to remove the cover.
3. Take out the old filter and insert a new filter. Then replace the filter cover.
4. Restore power to the device and hold the Reset button for 3 seconds until the filter indicator stops flashing. Proceed to the Flush the Filters section below.

Flushing the Filters

Press the Flush button on the panel to flush the filters. The flushing will be finished 60 seconds later. You can also press the Flush button a second time during the 60 second flush period to stop the flushing.

NOTE: The Flush button does not work when the device is in an automatic flushing state.

Warranty

Brio (“Vendor”) warrants to the original purchaser of the Brio Water Filters (the “Product”), and to no other person, that if the Product is assembled and operated in accordance with the printed instructions accompanying it, then for a period of one (1) year from the date of purchase, all parts in the Product shall be free from defects in material and workmanship. This Limited Warranty shall be limited to repair or replacement of parts, which prove defective under normal use and service and which Vendor shall determine in its reasonable discretion upon examination to be defective. To take advantage of this Limited Warranty, please follow these steps:

1. Please retain your sales slip or invoice, as Vendor may require reasonable proof of your date of purchase.
2. Contact Vendor’s Customer Service Department using the contact information listed below.
3. Return parts to Vendor, per Vendor’s instructions, at your cost and expense.
4. Upon receipt by Vendor, Vendor shall advise you in writing whether a defect covered by this Limited Warranty exists in any returned part and whether your claim has been approved or denied.
5. Upon Vendor’s approval of your claim, Vendor will replace such defective part without charge to you.

WHAT THIS LIMITED WARRANTY DOES NOT COVER: This Limited Warranty does not cover any failures or operating difficulties of the Product due to accident, abuse, misuse, alteration, misapplication, improper installation or improper maintenance or service by you or any third party, or failure to perform normal and routine maintenance on the Product, as set out in the User’s Manual. In addition, this Limited Warranty does not cover damages to the finish, such as scratches, dents, discoloration or rust after purchase.

This Limited Warranty is the only express warranty given on the Product and is in lieu of all other express warranties. Vendor disclaims all warranties for products that are purchased from seller other than authorized retailers or distributors. THIS LIMITED WARRANTY RESTRICTS THE DURATION OF ANY AND ALL IMPLIED WARRANTIES, INCLUDING WITHOUT LIMITATION, THE IMPLIED WARRANTY OF MERCHANTABILITY AND FITNESS FOR A PARTICULAR PURPOSE TO THE ONE (1) YEAR TERM OF THIS LIMITED WARRANTY. UPON THE EXPIRATION OF THE ONE (1) YEAR TERM OF THIS LIMITED WARRANTY, VENDOR DISCLAIMS ANY AND ALL IMPLIED WARRANTIES, INCLUDING WITHOUT LIMITATION THE IMPLIED WARRANTIES OF MERCHANTABILITY AND FITNESS FOR A PARTICULAR PURPOSE, THE PRODUCT BEING THUS SOLD AS-IS, WITH ALL FAULTS. FURTHER, VENDOR SHALL HAVE NO LIABILITY WHATSOEVER TO PURCHASER OR ANY THIRD PARTY FOR ANY SPECIAL, INDIRECT, PUNITIVE, INCIDENTAL, OR CONSEQUENTIAL DAMAGES. OTHER THAN THIS LIMITED WARRANTY, THERE ARE NO WARRANTIES WHICH EXTEND BEYOND THE DESCRIPTION ON THE FACE HEREOF. Vendor assumes no responsibility for any defects caused by third parties. This Limited Warranty gives you specific legal rights, and you may have other rights which vary from state to state. State law may also override statements in this Limited Warranty regarding the restriction on the duration of implied warranties. Some jurisdictions do not allow exclusion or limitation of special, incidental or consequential damages, or limitations on how long a warranty lasts, so the above exclusion and limitations may not apply to you.



Contact Us

Call: +1 844-257-4103