



Brio[®]

430

POINT-OF-USE WATER DISPENSER

Setup Manual

Model No.: CLPOU430UVF3

Table of Contents

Safety Information	3
Intended Use	4
Product Features	4
Indicator Panel Description	5
Operational Specifications	5
Technical Specifications	5
Package Contents	6
Materials Needed	6
Installation	6
Determine Installation Location	6
Install the Drip Tray and Grid	6
Connect the Cold Water Supply	7
Flush the Filters	8
Install the Filters and Complete the Installation	9
Operation	10
Turn the Dispenser On	10
Dispense Cold Water	10
Adjust the Cold Water Thermostat	10
Disable Child Safety Lock and Dispense Hot Water	10
Using the Leakage Detector	11
Troubleshooting	11
Cleaning and Maintenance	12
Filter Replacement Schedule	12
Replace the Filters	12
Clean the Reservoirs	13
Warranty	14

Safety Information

WARNING: To reduce risk of injury and property damage, you must read this entire guide before assembling, installing and operating the dispenser.

WARNING: This product dispenses water at very high temperatures. Failure to use properly can cause personal injury. When operating this dispenser, always exercise basic safety precautions, including the following:

- Prior to use, this dispenser must be properly assembled and installed in accordance with this manual.
- For indoor use only. Keep the water dispenser in a dry place away from direct sunlight. Do NOT use outdoors.
- Install and use only on a hard, flat and level surface.
- Do NOT place the water dispenser in an enclosed space or cabinet.
- Do NOT operate the dispenser in the presence of explosive fumes.
- Use only properly grounded outlets.
- Do NOT use an extension cord.
- Always grasp the plug and pull straight out from the outlet. Never unplug by pulling on the power cord.
- Do NOT use the dispenser if the cord becomes frayed or otherwise damaged. If the supply cord is damaged, it must be replaced by the manufacturer, its service agent or similarly qualified persons in order to avoid a hazard.
- To protect against electric shock, do NOT immerse cord, plug, or any other part of the dispenser in water or other liquids.
- Ensure the water dispenser is unplugged prior to cleaning.
- Never allow children to dispense hot water without proper and direct supervision. Unplug the unit to prevent unsupervised use by children.
- Service should be performed only by a certified technician.
- The appliance must not be cleaned by a water jet and is not suitable for installation in an area where a water jet could be used.

WARNING: Keep ventilation openings, in the dispenser enclosure or in the built-in structure, clear of obstruction.

WARNING: Do not use mechanical devices or other means to accelerate the defrosting process, other than those recommended by the manufacturer.

- Never turn the dispenser upside down or lean it more than 45°.
- After turning the dispenser off, allow the dispenser to sit idle for 3 minutes before turning on again.

WARNING: UV light source. Disconnect the electrical supply to the UV radiation BEFORE opening cover.

- UV-LED lamp must be repaired by manufacturer only.
- UV-LED lamp model no. JS-2017MDTY-B01, rated DC 12V, 3MW.
- Disposal of the LED-UV lamp must be done in accordance with local laws and regulations.

Intended Use

This dispenser is intended to be used in household and similar applications such as:

- Staff kitchen areas in shops, offices and other working environments
- Farm houses
- Hotels, motels and other residential-type environments
- Bed-and-breakfast environments
- Catering and similar non-retail applications

This dispenser is not intended for use by persons (including children) with reduced physical, sensory or mental capabilities, or lack of experience and knowledge, unless they have been given supervision or instruction concerning use of the appliance by a person responsible for their safety.

Product Features

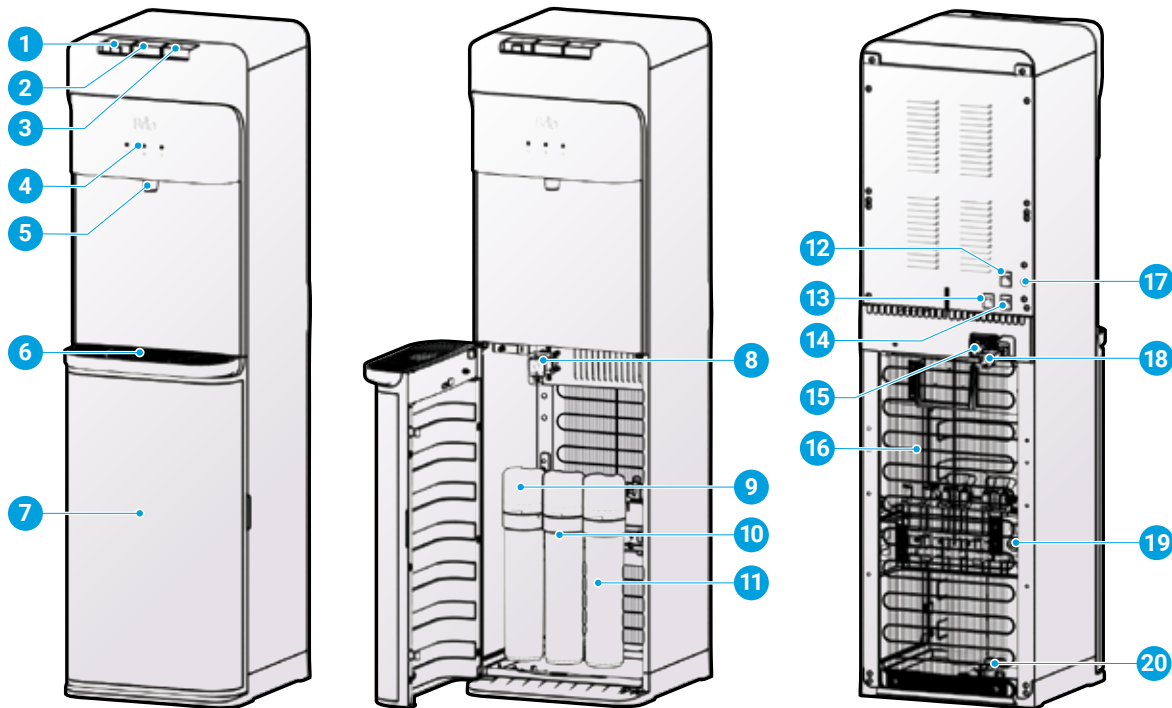

Part	Description
1	Hot water button
2	Room temperature water button
3	Cold water button
4	Indicator panel
5	Dispense point
6	Drip tray
7	Filter cabinet
8	Water inlet solenoid valve
9	Sediment filter
10	Pre carbon filter

Part	Description
11	Carbon block filter
12	Heating switch
13	Night light switch
14	Cooling switch
15	Hot water tank drain
16	Condenser
17	Cold water thermostat
18	Power cord
19	Water inlet
20	Leakage detector

Indicator Panel Description

1. Hot water indicator light - When illuminated, indicates that the dispenser is heating water.
2. Cold water indicator light - When illuminated, indicates that the dispenser is cooling water.
3. No water indicator light - When illuminated, indicates water flow to reservoir tanks has stopped.

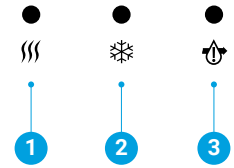
Operational Specifications

You must use the dispenser within the following operational parameters to ensure safe, optimal performance.

Model No.	CLPOU430UVF3
Rated Voltage / Frequency	115 V ~ 60 Hz
Heating Power	450 W
Cooling Power	85 W
Operating Ambient Temperature	39–100 °F (4–38 °C)
Operating Humidity	≤90%
Feedwater Pressure	14–87 psi
Feedwater Requirement	Municipal Tap Water with TDS <500 ppm*
Feedwater Temperature	39–100 °F (4–38 °C)

*If using well or ground water as feedwater source, ensure it has been through prefiltration before using with water filtration system.

Technical Specifications

CAUTION: This unit dispenses water at temperatures that can cause severe burns. Avoid direct contact with hot water. Keep children and pets away from unit while dispensing. Never allow children to dispense hot water without proper and direct supervision. Unplug unit to prevent unsupervised use by children.

Model No.	CLPOU430UVF3
Cold Water Tank Volume	3.7 L
Hot Water Tank Volume	1.0 L
Hot Water Capacity (Measured at Ambient Temperature of 77 °F / 25 °C)	7.5 L/h (≥165 °F / 73.9 °C)
Cold Water Capacity (Measured at Ambient Temperature of 77 °F / 25 °C)	2.2 L/h (≤50 °F / 10 °C)
Hot Water Flow Rate	≥1.5 L/min
Cold Water Flow Rate	≥2.7 L/min
Ambient Water Flow Rate	≥2.7 L/min
Net Weight	42.02 lb (19.1 kg)
Product Dimensions (WxHxD)	11.81 x 41.73 x 14.17 in. (30 x 104 x 34 cm)
Water Dispense Point to Water Drip Tray (H)	10.5 in. (26.67 cm)
Water Drip Tray Dimensions (WxD)	11.22 x 3.82 in. (28.5 x 9.7 cm)
Noise (dBA)	≤55 dB

Package Contents

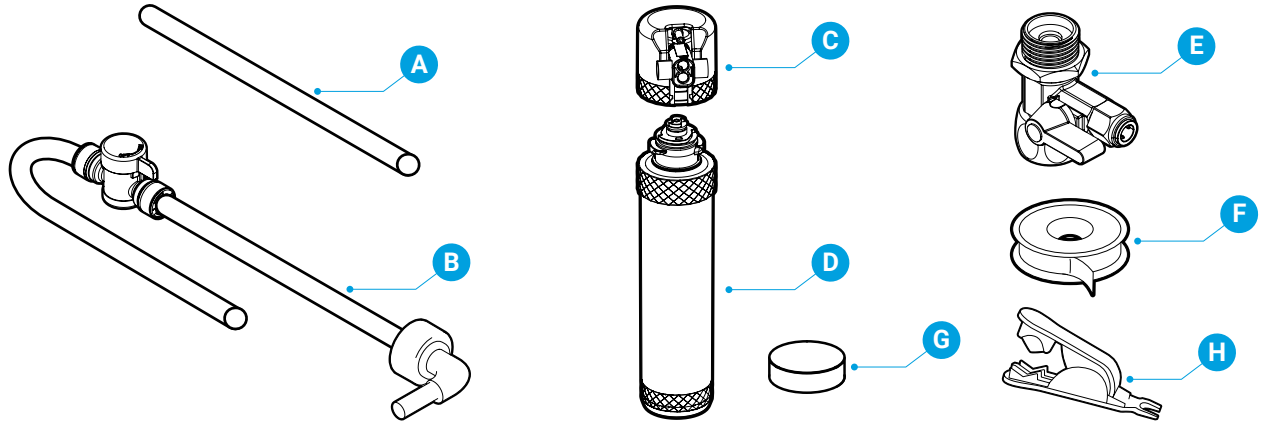

Part	Description	Quantity
A	Filter flushing tube	1
B	Shut-off valve tube (7 ft.)	1
C	Filter housing (for filter flushing)	1
D	Filter	3

Part	Description	Quantity
E	Feedwater adapter (with extra nut)	1
F	Plumber's tape	1
G	Expanding leakage sponge	3
H	Tube cutter	1

Materials Needed

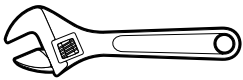

Wrench

Installation

Determine Installation Location

IMPORTANT: If the dispenser has been resting on its side for a long period of time, place it in the upright position for approximately 12 hours before installing.

- A. Locate the dispenser on a hard and level surface in a cool shaded location near a grounded wall outlet.
- B. Position the back of the dispenser no closer than 8 in. (20 cm) from wall to permit free airflow between the wall and water dispenser.

Install the Drip Tray and Grid

- A. Unwrap drip tray and grid (6) from the packaging material and slide it onto the dispenser until it is securely in place.

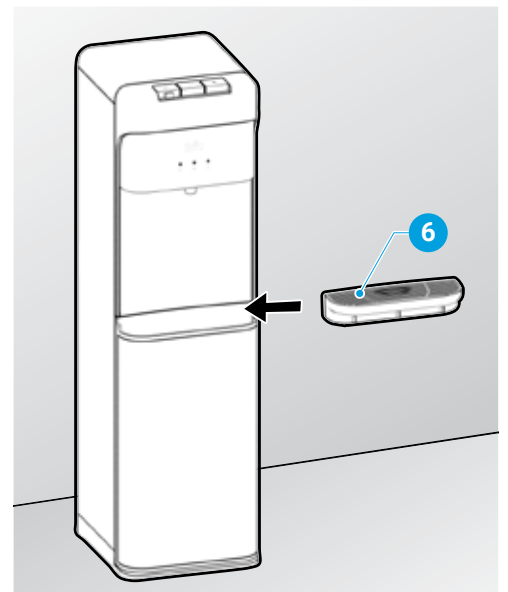

Connect to the Cold Water Supply

CAUTION: DO NOT CONNECT THIS WATER LINE TO A HOT WATER SUPPLY LINE. The water supply to the unit MUST be from the COLD WATER LINE. Using HOT WATER will severely damage your filters.

NOTE: Plumber's tape and a tube cutter have been included to facilitate installation. Use plumber's tape on threaded plumbing connections to ensure a secure seal.

- A. Turn off the cold water supply, then disconnect the cold water pipe from the cold water supply line.
- B. Connect the feedwater adapter (E) to the cold water supply line.
- C. Connect the cold water pipe to the top of the feedwater adapter (E).

NOTE: An extra adapter nut is included on top of the feedwater adapter (E) to attach to a 3/8 in. or 1/2 in. feed plumbing line.

- D. Insert the shut-off valve tube (B) straight into the quick connector piece of the feedwater adapter (E).

- E. Gently tug on the tube (B) to ensure a secure connection with the feedwater adapter (E).

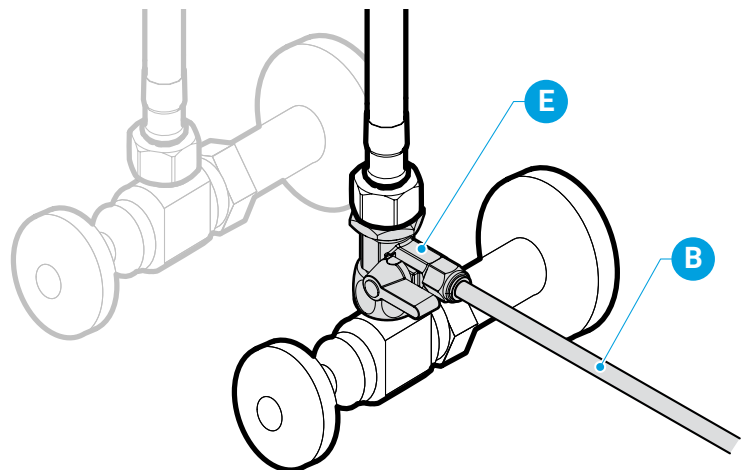
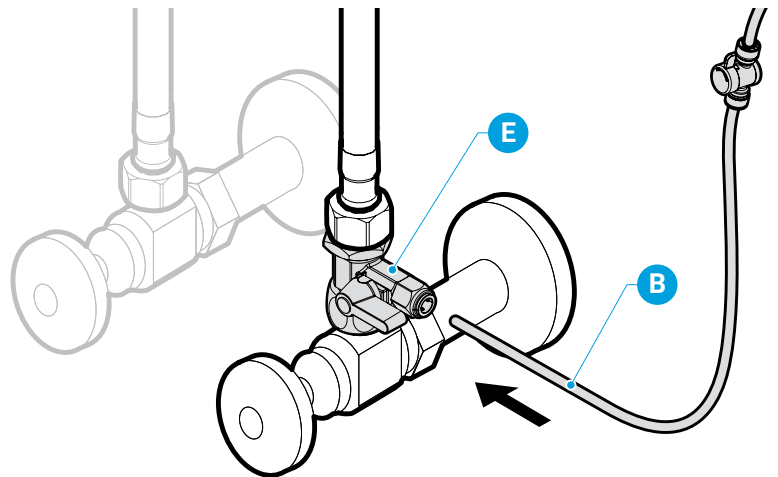
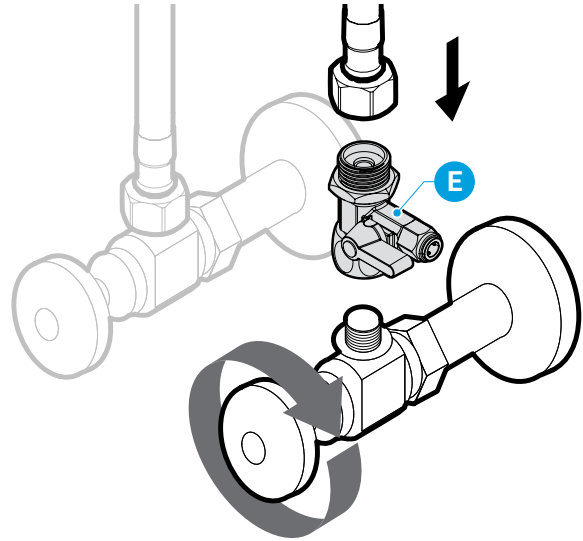

Flush the Filters

Follow this procedure each time you replace your filters.

IMPORTANT: Ensure water supply is off before you begin.

- A. Connect a filter (D) to the filter housing (C) by twisting the filter (D) clockwise.

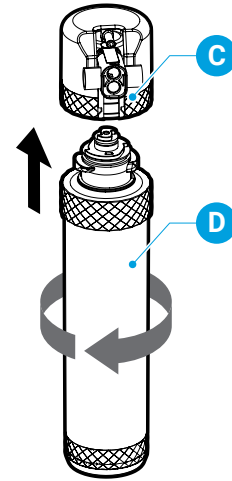

- B. Connect the tip of the shut-off valve tube (B) to the left side of the filter housing (C).
- C. Connect the filter flushing tube (A) to the right side of the filter housing (C) and lay the open end of the filter flushing tube (A) over a sink or receptacle to collect water.

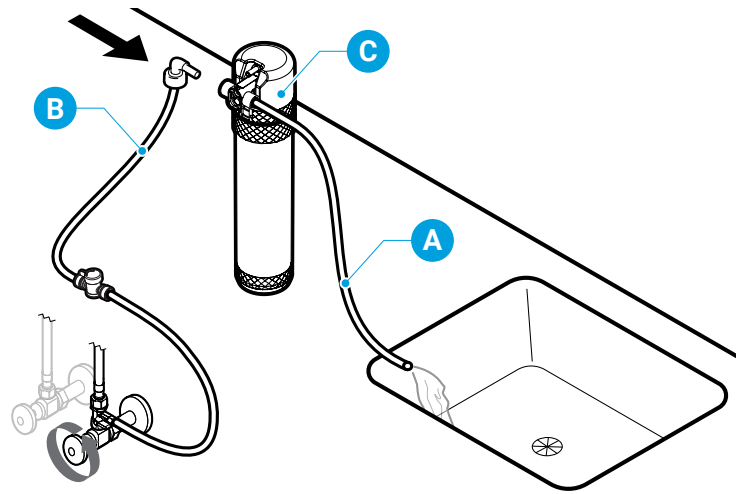

- D. Turn on water supply. Flush each filter for a minimum of 5 minutes. The recommended amount is 1.5-3 gallons of water (about 10 minutes) or until the water is clear in appearance.
- E. Shut off water supply and remove tube (B) from filter housing.

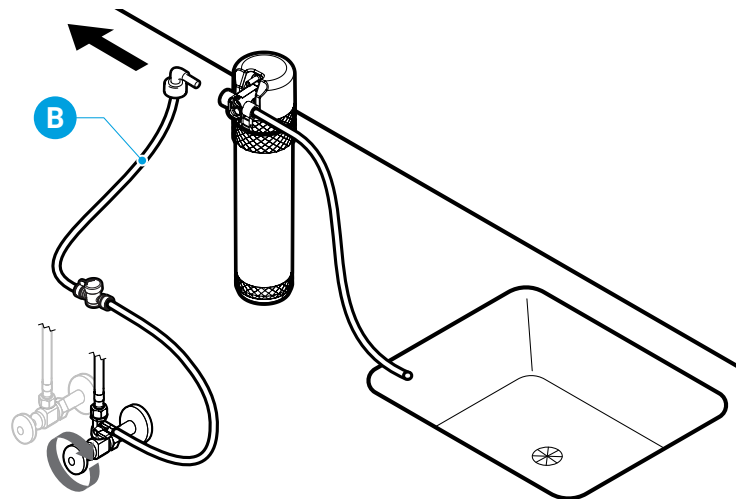

Install the Filters and Complete the Installation

- A.** After flushing, twist each filter clockwise into the filter housings located inside the dispenser cabinet. The sediment filter goes on the left, followed by the pre carbon filter and the carbon block filter.

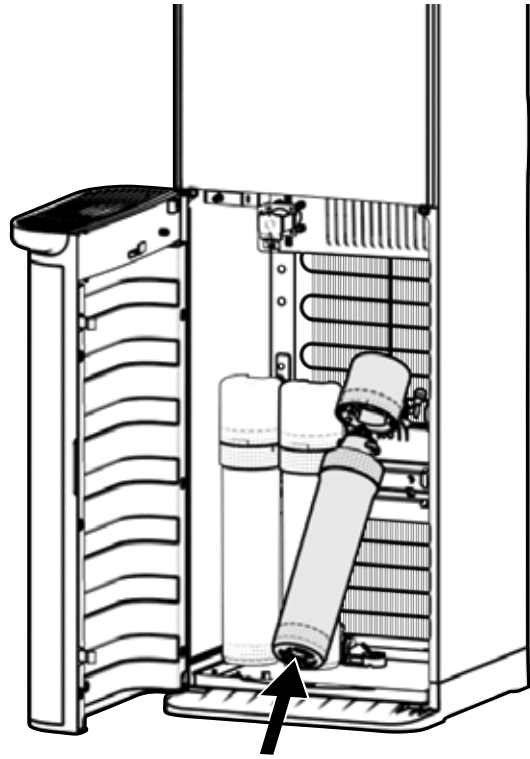

- B.** Remove the safety plug from the water inlet hole on the back of the dispenser by pushing in the inlet hole collar and then gently pulling out the plug.
- C.** Connect the tip of the shut-off valve tube (B) into the water inlet hole on the back of the dispenser. Then turn on the main water supply and ensure the valve in the tube (B) is on.

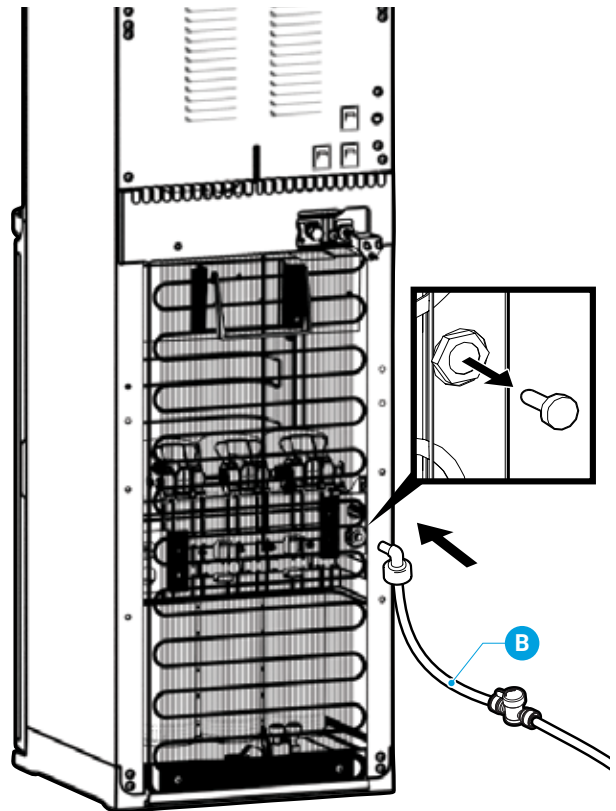

Operation

IMPORTANT: This unit has been tested and sanitized prior to packing and shipping. During transit, dust and odors can accumulate in the tank and lines. Dispense and dispose at least one quart of water prior to drinking any water.

Turn the Dispenser On

IMPORTANT: Before you activate the heating and cooling switches, ensure a water has filled reservoir tanks in order to prevent dry heating.

- A. To power on the cooling system, flip the cooling switch to the On position. It takes approximately 1 hour after turning on the cooling switch for the cold water to reach its coldest temperature. During the cooling process, the cold water indicator light will remain illuminated. Once the cold water has reached its coldest temperature, the cold water indicator light will turn off.
- B. To power on the heating system, flip the heating switch to the On position. It takes approximately 15 to 20 minutes after turning on the heating switch for hot water to reach its hottest temperature. During the heating process, the hot water indicator light will remain illuminated. Once the hot water has reached its hottest temperature, the hot water indicator light will turn off.

Dispense Cold Water

- A. Place a drinking glass or container under the tap and press cold water button to dispense cold water.
- B. Release when your container is full.

Adjust the Cold Water Thermostat

The cold water reservoir temperature is monitored by a cold water thermostat (17) located at the rear of the dispenser. Using a screwdriver, turn the set screw clockwise between the lower setting for warmer water and higher setting for colder water until the desired temperature is reached. If water is not being properly dispensed, there could be possible ice build-up in the reservoir due to the thermostat being set too cold. If this happens, slowly rotate the thermostat set screw counterclockwise to a warmer setting.

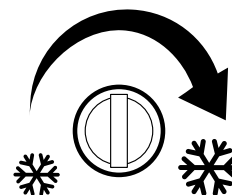

Disable Child Safety Lock and Dispense Hot Water

CAUTION: This unit dispenses water at temperatures that can cause severe burns. Avoid direct contact with hot water. Keep children and pets away from the unit while dispensing. Never allow children to dispense hot water without proper and direct supervision. Disable the heating feature by switching the heating switch to the Off position.

- A. This water dispenser is equipped with a child safety feature in order to prevent inadvertent dispensing. To enable dispensing of hot water, place a cup or container under the tap. Simultaneously press in the red lock button on the front of the hot water button while pressing the hot water button down.
- B. Release the red lock button and hot water button once your container is full. Hot water will automatically relock.

Using Leakage Detector

This dispenser is equipped with a mechanical water leakage detector. If there is a leak inside the filter cabinet, the expanding leakage sponge will immediately expand, forcing the lid on the leak detector open, halting water flow to the reservoir tanks, and preventing any further damage. The No Water Indicator Light on the Indicator Panel will illuminate. If there is a leak, do the following:

- A.** Unplug dispenser and turn off the water supply to the dispenser. Inside the filter cabinet, determine if a component or filter has come loose, or if a tube has cracked. Reinstall or replace any part or parts if necessary.
- B.** Mop up water on floor of cabinet, remove and discard the used leakage sponge, then install a new one by inserting it into the leakage detector compartment. Snap lid leakage detector lid closed. Turn the water supply back on and plug in dispenser.

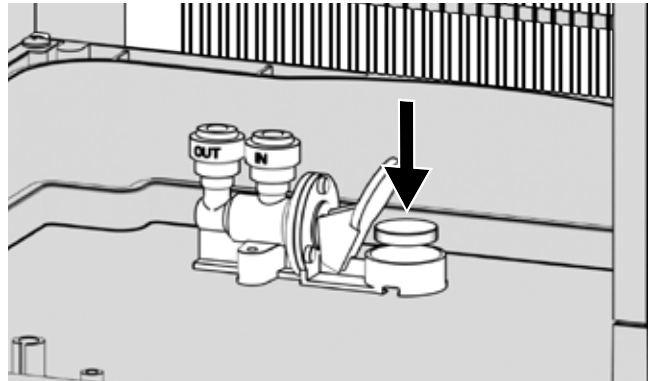

Troubleshooting

Problem	Solution
The cold water is not cold.	<ul style="list-style-type: none"> • It takes up to one hour after setup to dispense cold water. • Make sure the power cord is properly connected to a working outlet. • Make sure the back of the dispenser is at least 8 inches from wall and there is free airflow on all sides of the dispenser. • Make sure green power switch on back of dispenser is On. • Using a screwdriver, turn the cold water thermostat set screw clockwise (to the right) until desired temperature is reached.
The hot water is not hot.	<ul style="list-style-type: none"> • It takes 15-20 minutes after setup to dispense hot water. • Make sure the power cord is properly connected to a working outlet. • Make sure red heating switch on back of dispenser is On.
The dispenser is noisy.	<ul style="list-style-type: none"> • Ensure the dispenser is located on a level surface. • The heating tube may be generating a slight noise. This is normal.
The dispenser is not dispensing water.	<ul style="list-style-type: none"> • Ensure water supply is on and valve on shut-off valve tube is open. • If the No Water Indicator Light is illuminated, there may be a leak. Follow the instructions under “Using the Leakage Detector.” • If the No Water Indicator Light is illuminated and there is no leak, one or more of the filters may be clogged. Follow the instructions under “Replace the Filters.”

Cleaning and Maintenance

This dispenser runs on a continuous UV cleaning cycle. It works for 40 minutes, turns off for 140 minutes, then cycles back on. This process repeats as long as the dispenser is plugged in and on.

Filter Replacement Schedule

Filter Type	Model No.	Replacement Schedule	Function
Sediment	NFMPP5M	6-12 months or 950 gallons	Performs coarse filtration of inlet water, removing sand, rust, dirt, and other suspended solids.
Pre Carbon	NFMGAC	6-12 months or 950 gallons	Removes chlorine, and other unpleasant tastes and odors.
Carbon Block	NFMCTO5MS3	6-12 months or 950 gallons	Performs final polish, removing any residual impurities.

Replace the Filters

IMPORTANT: Only use filters designed for this dispenser. Any other type of filter will damage the machine and void any warranty.

Depending on frequency of dispenser use and source water quality, filters must be replaced every 6 to 12 months. To replace, do the following:

- A. Shut off water supply to dispenser.
- B. To flush new filters, follow the instructions on page 8, “Flush the Filters.”
- C. Remove the old filters and replace with new filters. Ensure filters are installed as follows, from left to right: sediment, pre carbon, and carbon block.
- D. Turn water supply to dispenser back on.

Cleaning the Reservoirs

The reservoirs should be cleaned every 3 to 4 months to remove mineral buildup and optimize dispenser performance.

Gather the following supplies:

- 60–120g (4–8 tbsp.) citric acid crystals
- 2 Liters hot water
- 5 Liter (1.3 gal.) container or bucket
- Screwdriver
- Clean dry cloth

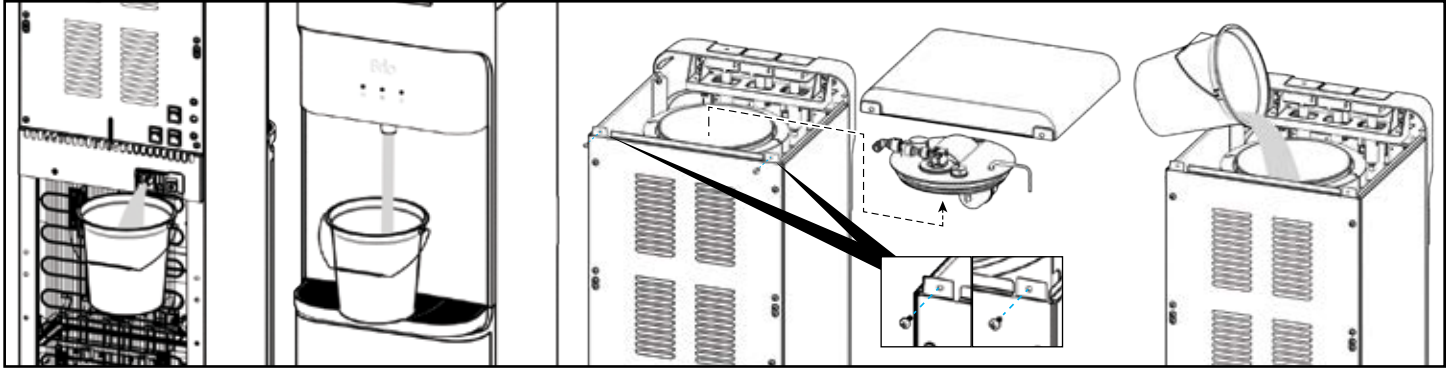

- Turn the heating and cooling switches to the OFF position, and unplug the dispenser.
- Move the dispenser away from the wall to gain access to the back. Turn the shut-off valve on the shut-off valve tube to the OFF position.
- At the back of the dispenser, place the 5-liter container beneath the hot-water drain. Open the drain and allow hot water to drain into the container, emptying the reservoir tank. Close hot-water drain. Dispose of water.
CAUTION: Drained water may be hot.
- Place the empty 5-liter container under the water dispense point. Press the dispense buttons to drain any remaining water from the reservoir tanks. Dispose of water.
- Use the screwdriver to remove the screws securing the dispenser top. Then remove the cold water reservoir tank cover. Carefully allow it to hang down the side of the dispenser.
- Prepare the cleaning solution by combining citric acid crystals with 2 liters of hot water. Slowly stir the solution so that all the crystals are dissolved.
- Pour solution into the cold water reservoir tank (it will trickle down to the hot water reservoir tank). Allow solution to sit in reservoir tanks for at least 10 minutes.
- Dispense some of the solution from the dispense point.
- Place the 5-liter container beneath the hot-water drain. Open the drain and allow solution drain into the container, emptying the reservoir tank. Close hot-water drain. Dispose of cleaning solution.
- Refill cold water tank with 2 liters of fresh water. Dispense some of the rinse water from the dispense point. Place the container beneath the hot-water drain and drain the rinse water.
- Repeat rinsing process if necessary.
- Reinstall cold water tank cover and dispenser top.
- Turn the shut-off valve on the shut-off valve tube to the ON position. Plug in the dispenser, allowing reservoir tanks to refill, then turn the heating and cooling switches to the ON position.

Warranty

Brio (“Vendor”) warrants to the original purchaser of the Brio Water Coolers (the “Product”), and to no other person, that if the Product is assembled and operated in accordance with the printed instructions accompanying it, then for a period of one (1) year from the date of purchase, all parts in the Product shall be free from defects in material and workmanship. This Limited Warranty shall be limited to repair or replacement of parts, which prove defective under normal use and service and which Vendor shall determine in its reasonable discretion upon examination to be defective. To take advantage of this Limited Warranty, please follow these steps:

1. Please retain your sales slip or invoice, as Vendor may require reasonable proof of your date of purchase.
2. Contact Vendor’s Customer Service Department using the contact information listed below.
3. Return parts to Vendor, per Vendor’s instructions, at your cost and expense.
4. Upon receipt by Vendor, Vendor shall advise you in writing whether a defect covered by this Limited Warranty exists in any returned part and whether your claim has been approved or denied.
5. Upon Vendor’s approval of your claim, Vendor will replace such defective part without charge to you.

WHAT THIS LIMITED WARRANTY DOES NOT COVER: This Limited Warranty does not cover any failures or operating difficulties of the Product due to accident, abuse, misuse, alteration, misapplication, improper installation or improper maintenance or service by you or any third party, or failure to perform normal and routine maintenance on the Product, as set out in the User’s Manual. In addition, this Limited Warranty does not cover damages to the finish, such as scratches, dents, discoloration or rust after purchase.

This Limited Warranty is the only express warranty given on the Product and is in lieu of all other express warranties. Vendor disclaims all warranties for products that are purchased from seller other than authorized retailers or distributors. THIS LIMITED WARRANTY RESTRICTS THE DURATION OF ANY AND ALL IMPLIED WARRANTIES, INCLUDING WITHOUT LIMITATION, THE IMPLIED WARRANTY OF MERCHANTABILITY AND FITNESS FOR A PARTICULAR PURPOSE TO THE ONE (1) YEAR TERM OF THIS LIMITED WARRANTY. UPON THE EXPIRATION OF THE ONE (1) YEAR TERM OF THIS LIMITED WARRANTY, VENDOR DISCLAIMS ANY AND ALL IMPLIED WARRANTIES, INCLUDING WITHOUT LIMITATION THE IMPLIED WARRANTIES OF MERCHANTABILITY AND FITNESS FOR A PARTICULAR PURPOSE, THE PRODUCT BEING THUS SOLD AS-IS, WITH ALL FAULTS. FURTHER, VENDOR SHALL HAVE NO LIABILITY WHATSOEVER TO PURCHASER OR ANY THIRD PARTY FOR ANY SPECIAL, INDIRECT, PUNITIVE, INCIDENTAL, OR CONSEQUENTIAL DAMAGES. OTHER THAN THIS LIMITED WARRANTY, THERE ARE NO WARRANTIES WHICH EXTEND BEYOND THE DESCRIPTION ON THE FACE HEREOF. Vendor assumes no responsibility for any defects caused by third parties. This Limited Warranty gives you specific legal rights, and you may have other rights which vary from state to state. State law may also override statements in this Limited Warranty regarding the restriction on the duration of implied warranties. Some jurisdictions do not allow exclusion or limitation of special, incidental or consequential damages, or limitations on how long a warranty lasts, so the above exclusion and limitations may not apply to you.

Brio[®]

WWW.BRIOWATER.COM

©2024 Brio Water Technology, Inc.