



Brio[®]

Water Dispenser
Installation and Operation
Manual

Model No.: CLNLPOU520SCF2B

Table of Contents

Safety Information	3
Intended Use	4
Package Contents	4
Indicator Panel Description	5
Product Dimensions	5
Operational Specifications	5
Installation	5
Determine Installation Location	5
Install the Drip Tray and Grid	5
Install the Filters	6
Connect the Water Bottle	6
Flush the Filters	7
Operation	7
Turn on the Hot and Cold Switches	7
Dispense Cold Water	7
Disable Child Safety Lock and Dispense Hot Water	8
Refill the Water Bottle	8
Cleaning and Maintenance	8
Clean the Water Pump	9
Use the Self-Cleaning Ozone Feature	10
Filter Replacement Schedule	10
Replace the Filters	10
Filter Specifications	11
Care and Maintenance	11
Troubleshooting Guide	12
Warranty	13

Safety Information

WARNING: To reduce risk of injury and property damage, you must read this entire guide before assembling, installing, and operating the dispenser.

WARNING: This product dispenses water at very high temperatures. Failure to use properly can cause personal injury. When operating this dispenser, always exercise basic safety precautions, including the following:

- Do NOT use this dispenser with water that is microbiologically unsafe or of unknown quality.
- Prior to use, this dispenser must be properly assembled and installed in accordance with this manual.
- For indoor use only. Keep the water dispenser in a dry place away from direct sunlight. Do NOT use outdoors.
- Install and use only on a hard and level surface.
- Do NOT place the water dispenser in an enclosed space or cabinet.
- Do NOT operate the dispenser in the presence of explosive fumes.
- Only use properly grounded outlets.
- Do NOT use an extension cord.
- Always grasp the plug and pull straight out from the outlet. Never unplug by pulling on the power cord.
- Do NOT use the dispenser if the cord becomes frayed or otherwise damaged. If the supply cord is damaged, it must be replaced by the manufacturer, its service agent, or similarly qualified persons in order to avoid a hazard.
- To protect against electric shock, do NOT immerse cord, plug, or any other part of the dispenser in water or other liquids.
- Water dispenser is compatible with 3- or 5-gallon (12- or 19-liter) water bottles. Clean bottle before use.
- Clean up all water spills after loading or unloading water bottles into or from the dispenser.
- Ensure the water dispenser is unplugged prior to cleaning.
- Never allow children to dispense hot water without proper and direct supervision. Always enable the child safety lock feature to prevent unsupervised use by children.
- Service should be performed only by a certified technician.
- Do NOT clean the dispenser with a water jet. Do NOT install in an area where a water jet could be used.

WARNING: Keep ventilation openings in the dispenser enclosure or in the built-in structure clear of obstruction.

WARNING: Do NOT use mechanical devices or other means to accelerate the defrosting process, other than those recommended by the manufacturer.

- This dispenser should work under environmental temperatures from 39–104 °F (4–40 °C) and humidity ≤90%.
- Never turn the dispenser upside down or lean it more than 45°.
- After turning off the red hot-water switch and the green cold-water switch, allow the dispenser to sit idle for 3 minutes before turning on switches again.

Intended Use

This dispenser is intended to be used in household and similar applications such as:

- Staff kitchen areas in shops, offices, and other working environments
- Farm houses
- Hotels, motels, and other types of residential environments
- Bed-and-breakfast environments
- Catering and similar non-retail applications

This dispenser is not intended for use by persons (including children) with reduced physical, sensory, or mental capabilities, or lack of experience and knowledge, unless they have been given supervision or instruction concerning use of the appliance by a person responsible for their safety.

Package Contents

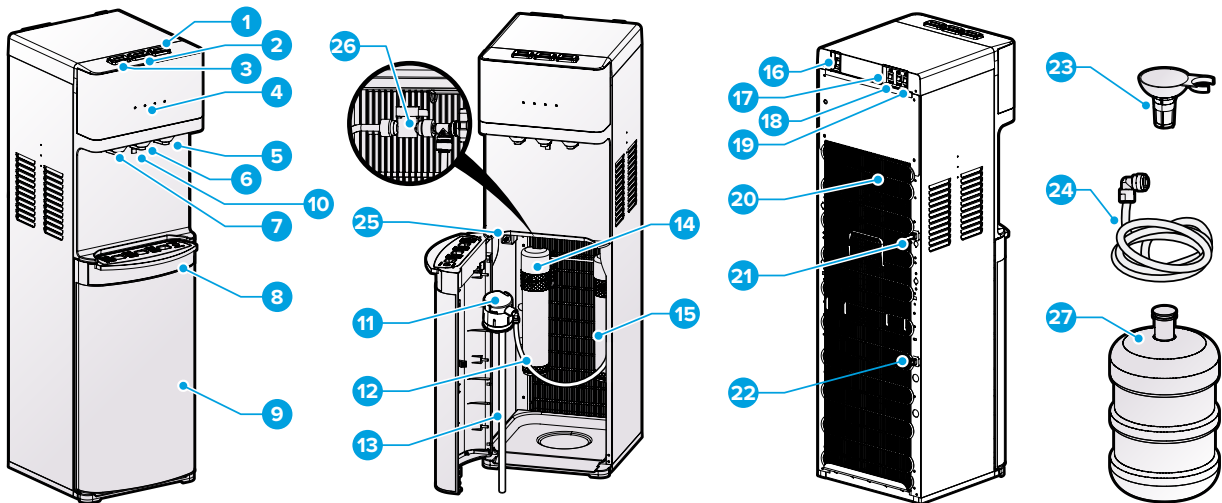

Part	Description
1	Cold water button
2	Room temperature water button
3	Hot water button
4	Indicator panel
5	Cold water tap
6	Room temperature water tap
7	Hot water tap
8	Drip tray
9	Water bottle cabinet
10	Night light
11	Bottle adapter
12	Water line
13	Bottle adapter tube
14	Sediment filter

Part	Description
15	Carbon block filter
16	Self-cleaning switch
17	Night light switch
18	Cold water switch
19	Hot water switch
20	Condenser
21	Drain outlet
22	Pump cleaning drain
23	Funnel
24	Drain hose
25	Filter reset switch
26	Ball valve switch
27	5-Gallon bottle

Indicator Panel Description

1. Power indicator – When illuminated, indicates that the dispenser is on. When blinking, indicates that the self-cleaning feature is operating.
2. Hot water indicator light – When illuminated, indicates that the dispenser is heating water.
3. Cold water indicator light – When illuminated, indicates that the dispenser is cooling water.
4. Bottle indicator light – When blinking slowly, indicates water bottle is empty and needs to be refilled; when blinking quickly, indicates the filter is about to expire; and when steadily illuminated, indicates the filter has expired.



Product Dimensions

Height	Width	Depth
41.4 in. (105.1 cm)	12.2 in. (31.1 cm)	15.6 in. (39.6 cm)

Operational Specifications

CAUTION: This unit dispenses water at temperatures that can cause severe burns. Avoid direct contact with hot water. Keep children and pets away from unit while dispensing. Never allow children to dispense hot water without proper and direct supervision. Unplug unit to prevent unsupervised use by children.

	Temperature	Tank Volume	Flow Rate
Dispensing Cold Water	37°–50 °F (3°–10 °C)	3.6 L	1.2 L/min
Dispensing Hot Water	176°–198 °F (80°–92 °C)	1 L	1.2 L/min

Installation

1. Determine Installation Location

- A. Place the dispenser upright, on a hard and level surface.
- B. Ensure the dispenser is placed in a cool, shaded setting near a grounded wall outlet.

NOTICE: Do NOT plug in the power cord until water bottle has been installed.

- C. Position the back of the dispenser no closer than 8 in. (20 cm) from a wall in order to permit free airflow between the wall and water dispenser.

2. Install the Drip Tray and Grid

- A. Unwrap the removable drip tray and grid (8) from the packaging material. Attach the grid to the drip tray, then slide them into the dispenser until securely in place.

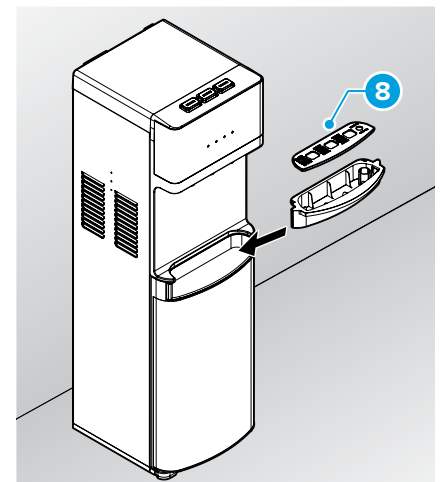

3. Install the Filters

- A. Twist each filter clockwise into the filter housings located inside the dispenser cabinet. The sediment filter (14) goes on the left, the carbon block filter (15) goes on the right.

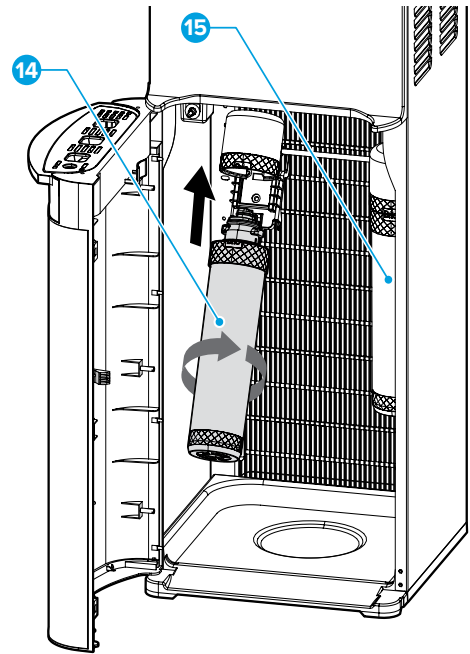

4. Connect the Water Bottle

IMPORTANT: To prevent dry heating, do NOT turn the red hot-water and green cold-water switches on the back of the unit to the On position until you complete the steps in this procedure.

- A. Clean the top of the 5-gallon water bottle with a clean cloth and fill with tap water. Use the funnel (23), if necessary.

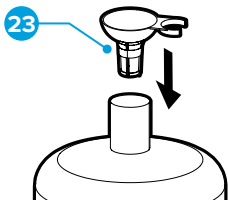

- B. Open the water bottle cabinet door and feed the bottle adapter tube (13) into the water bottle. Ensure the bottle adapter tube hits the bottom of the bottle.
- C. Fasten the bottle adapter (11) over the neck of the water bottle and press securely into place.

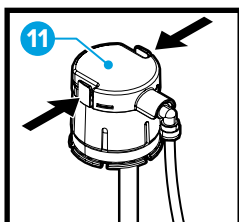
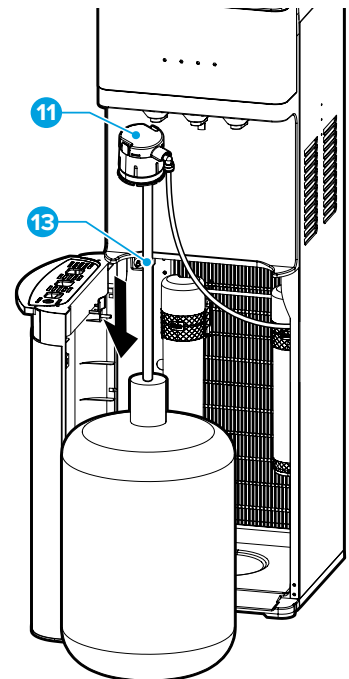

- D. Carefully slide the water bottle into the dispenser cabinet and gently close the door.
- E. Plug the unit into a wall outlet. Wait 5 minutes for the water tanks to fill with water before attempting to use the dispenser.

NOTE: Water will not pump from the bottle until the door is completely closed.

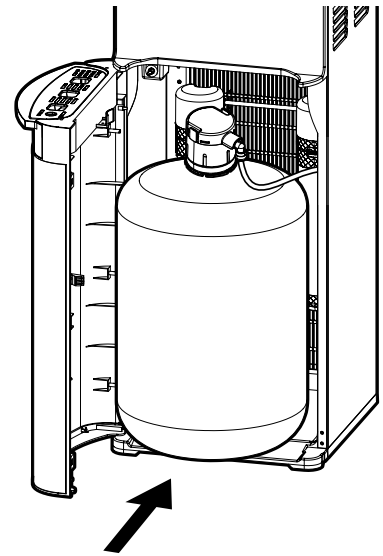

5. Flush the Filters

Before first use and after replacing the filters each time, place a bucket below the drain outlet (21). Open the drain outlet and attach the drain hose (24), threading the free end into the bucket. Flush the filters for 5 to 10 minutes or until the water runs clear. Remove drain hose. Close drain outlet. Discard water.

Operation

IMPORTANT: This unit has been tested and sanitized prior to packing and shipping. During transit, dust and odors can accumulate in the tank and lines. Dispense and dispose of at least 1 quart of water prior to drinking any water.

Turn on the Hot and Cold Switches

IMPORTANT: Before you turn on the red hot-water and green cold-water switches, ensure a bottle is installed and tanks have filled with water.

1. Press the hot, room temperature, and cold water buttons until water begins to dispense from the taps.
2. To power on the cooling system, flip the green cold-water switch on the back of the unit to the On position.
3. To power on the heating system, flip the red hot-water switch on the back of the unit to the On position.

Dispense Cold Water

NOTE: Please allow approximately 1 hour after turning the green cold-water switch to the On position for the water to become fully chilled. The cooling light will turn off once the water is completely chilled.

1. Place a drinking glass or container under the tap and press the cold water button on top of the dispenser to dispense cold water.
2. Release when your container is full.

Disable Child Safety Lock and Dispense Hot Water

CAUTION: This unit dispenses water at temperatures that can cause severe burns. Avoid direct contact with hot water. Keep children and pets away from the unit while dispensing. Never allow children to dispense hot water without proper and direct supervision. Disable the heating feature by switching the red hot-water switch to the Off position.

NOTE: Water will take approximately 15-20 minutes after switching on to reach its hottest temperature. The heating light will turn off once the water has been fully heated.

1. This water dispenser is equipped with a child safety feature in order to prevent inadvertent dispensing. To enable dispensing of hot water, place a cup or container under the hot water tap. Slide the red lock button on the hot water button to the left. While holding the red button, press the hot water button and dispense hot water.
2. Release the hot water button once your container is full.

Refill the Water Bottle

CAUTION: Do NOT dispense hot, room temperature, or cold water if the red bottle indicator light is flashing. You could empty the tanks and cause the dispenser to overheat.

When the bottle indicator light on the front-right of the dispenser flashes red, it is time to refill your water bottle:

1. Open the dispenser cabinet door and slide the empty bottle out of the cabinet.
2. Remove the bottle adapter and bottle adapter tube from the empty bottle, letting any water drip into the bottle. Once dripping has stopped, place the bottle adapter on the door hanger.
3. Follow the steps in Connect the Water Bottle, on page 6.

Cleaning and Maintenance

Task	Frequency	Instruction
Sanitizing	Every 3 months	Use a disinfectant, purchased separately, and follow directions from manufacturer for proper amount to use.
Removing mineral deposits	Every 6 months	Mix 1 gallon (4 liters) of water with 7 oz (200 g) of citric acid crystals. Remove top of dispenser and pour solution directly into water tank. Allow some solution to flow out of tap. Turn on red hot-water switch on the back of the unit and allow water to heat for about 10 minutes. After 30 minutes, drain the liquid by unplugging the drain outlet on the back of the dispenser and allowing solution to drain into a receptacle. Then flush the tank with fresh water, allowing it to dispense in the same manner. Repeat flushing process 1 or 2 times more.
Cleaning the water pump	Every 6 months or if pump is working slowly	To remove mineral deposits that have built up inside the water pump, please follow the instructions in the section that follows.

Clean the Water Pump

Gather the following supplies:

- 50g (1.75 oz.) citric acid crystals
- 1.5 gallons water
- 2 buckets (or 1 bucket and spare 5-gallon bottle)
- small container
- clean dry cloth

- A.** Pour citric acid crystals, then 1.5 gallons water into one of the buckets (or spare 5-gallon bottle). Stir or agitate to mix solution.
- B.** Open water bottle cabinet door. Remove 5-gallon bottle from cabinet. Remove bottle adapter tube from bottle.
- C.** Turn ball valve switch (26) located above sediment filter to the OFF position (perpendicular to tubing).

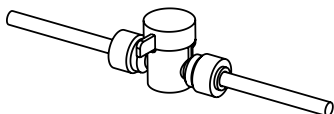

- D.** Insert the bottle adapter tube into the 5-gallon bottle or bucket containing the cleaning solution.
- E.** Place the second bucket at the back of the cooler, right below the pump cleaning drain (22).

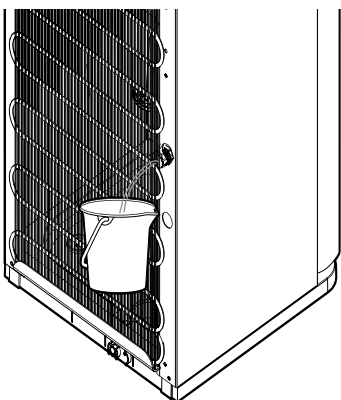

- F.** Remove the plug from the pump cleaning drain (22) by simultaneously pressing in the gray ring and pulling out the plug.

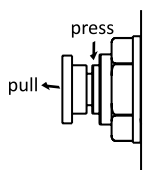

- G.** Place small container beneath cold water tap. Press the cold water button and dispense water for 3 seconds to activate the pump.
- H.** The pump will begin pumping the cleaning solution from the bottle or bucket out through the pump cleaning drain and into the second bucket.
- I.** Once the cleaning solution has been depleted, refill the empty container with a gallon of fresh tap water and repeat the process to flush the system.
- J.** When finished, push the plug back into the pump cleaning drain and turn the ball valve switch to the open/on position (parallel to the tubing).

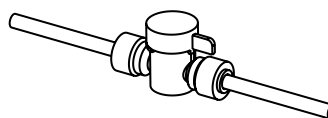

Use the Self-Cleaning Ozone Feature

It is highly recommended that you use the self-cleaning feature on a weekly basis to sanitize tanks and water lines. To activate the self-cleaning cycle, press the self-cleaning switch (16), hold for 5 seconds, then release. The power indicator light on the front of the dispenser will begin blinking, indicating the cleaning process is underway.

During the cleaning cycle, ozone is produced and injected into the water system. This ozone kills bacteria and biofilms typically found in water dispensers. By the time the cleaning cycle ends, the ozone is converted to harmless oxygen and emitted into the air.

IMPORTANT: The cycle takes 90 minutes to complete. During this time do not dispense and drink the water. Doing so may result in an odd taste. For your convenience, we recommend that you do this during a period when the dispenser is not in use, such as overnight hours or when staff is away from the office. During the cleaning cycle you may smell a faint trace of ozone.

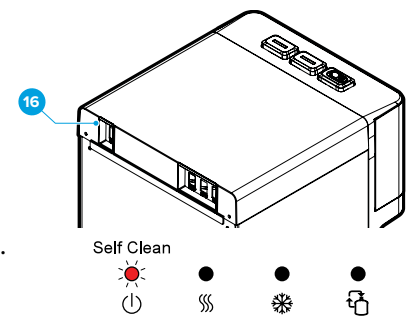

Filter Replacement Schedule

Filter Type	Model No.	Replacement Schedule	Function
Sediment	NFMPP5M	6 months or 950 gallons	Performs a coarse filtration of inlet water, removing sand, rust, dirt, and other suspended solids.
Carbon Block	NFMCTO5MS2	6 months or 950 gallons	Reduces chlorine and residual impurities.

Replace the Filters

IMPORTANT: Only replace the filters with new filters designed for this dispenser. Any other type of filter will damage the machine and void any warranty.

When a filter is approaching the end of its life (around 5 1/2 months), the red bottle-indicator light starts to blink quickly. When the filter has reached the end of its life (around 6 months), the red bottle-indicator light remains steadily illuminated.

To change the filters:

1. Remove the old filters by twisting counterclockwise. Attach new filters by twisting clockwise. Ensure the sediment filter is on the left and the carbon block filter is on the right.
2. To flush your new filters, follow the instructions in Step 5 - Flush the Filters, page 7.
3. Press the filter reset switch (25) 3 times until the red indicator light turns off.

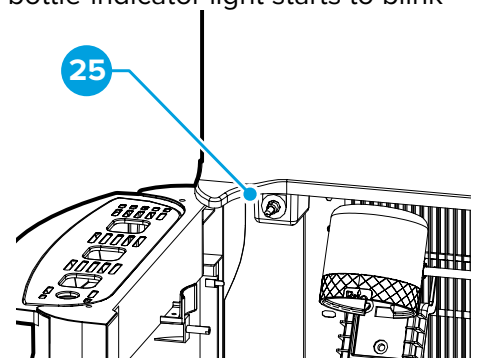

Filter Specifications

Sediment Filter

(Sediment, Dirt, and Rust Removal)

Filter Capacity	950 Gallons
Flow Rate	0.8 GPM
Suggested PSI	14.5—58 psi
Temperature	33—100 °F

Carbon Block Filter

(Chlorine, Taste, and Odor Reduction)

Filter Capacity	950 Gallons
Flow Rate	0.8 GPM
Suggested PSI	14.5—58 psi
Temperature	33—100 °F

Care and Maintenance

- Keep this dispenser in a dry and cool place. Avoid placing in direct sunlight.
- Never set the dispenser on paper or foam, which may store water and cause creepage. Never put anything flammable beside a foam or paper surface.
- Do not use the dispenser outdoors or in a place that can be splashed by water.
- If the dispenser is not in use for longer than a 24-hour period, turn off the red hot-water and green cold-water switches to save power, and drain any remaining water.
- Clean your cabinet, controls, bottle adapter tube, and water taps each time you change or refill your water bottle. Use a soft, clean cloth and a food-grade sanitizer or bleach.
- Empty and clean the drip tray and grid as needed.

Troubleshooting Guide

Refer to the table below for possible problems and their solutions.

Problem	Solution
The cold water is not cold.	<ul style="list-style-type: none">• It takes approximately one hour after setup to dispense cold water.• Make sure the power cord is properly connected to a working outlet.• Make sure the dispenser is at least 8 in. (20 cm) from all walls, especially the back wall, and that there is free airflow on all sides.• Make sure green cold-water switch on back of dispenser is in the On position.
The hot water is not hot.	<ul style="list-style-type: none">• It takes 15-20 minutes after setup to dispense hot water.• Make sure the power cord is properly connected to a working outlet.• Make sure red hot-water switch on back of dispenser is in the On position.
The night light is not working.	<ul style="list-style-type: none">• Make sure the power cord is properly connected to a working outlet.• Make sure the night light power switch on back of dispenser is in the On position.
The dispenser is noisy.	<ul style="list-style-type: none">• Ensure the dispenser is located on a hard, level surface.• The heating tube may be generating a slight sound. This is normal.
The bottle is leaking.	<ul style="list-style-type: none">• Ensure the bottle is installed correctly.• Check to see if the bottle is cracked or broken. If so, replace the bottle with a new one.
The dispenser is not dispensing water.	<ul style="list-style-type: none">• Check to see if the bottle is empty and refill if necessary.• There may still be air in the tank. Press and hold the water buttons to remove air until water begins to flow.

Warranty

Brio (“Vendor”) warrants to the original purchaser of the Brio Water Coolers (the “Product”), and to no other person, that if the Product is assembled and operated in accordance with the printed instructions accompanying it, then for a period of one (1) year from the date of purchase, all parts in the Product shall be free from defects in material and workmanship. This Limited Warranty shall be limited to repair or replacement of parts, which prove defective under normal use and service and which Vendor shall determine in its reasonable discretion upon examination to be defective. To take advantage of this Limited Warranty, please follow these steps:

1. Please retain your sales slip or invoice, as Vendor may require reasonable proof of your date of purchase.
2. Contact Vendor’s Customer Service Department using the contact information listed below.
3. Return parts to Vendor, per Vendor’s instructions, at your cost and expense.
4. Upon receipt by Vendor, Vendor shall advise you in writing whether a defect covered by this Limited Warranty exists in any returned part and whether your claim has been approved or denied.
5. Upon Vendor’s approval of your claim, Vendor will replace such defective part without charge to you.

WHAT THIS LIMITED WARRANTY DOES NOT COVER: This Limited Warranty does not cover any failures or operating difficulties of the Product due to accident, abuse, misuse, alteration, misapplication, improper installation or improper maintenance or service by you or any third party, or failure to perform normal and routine maintenance on the Product, as set out in the User’s Manual. In addition, this Limited Warranty does not cover damages to the finish, such as scratches, dents, discoloration, or rust after purchase.

This Limited Warranty is the only express warranty given on the Product and is in lieu of all other express warranties. Vendor disclaims all warranties for products that are purchased from seller other than authorized retailers or distributors. THIS LIMITED WARRANTY RESTRICTS THE DURATION OF ANY AND ALL IMPLIED WARRANTIES, INCLUDING WITHOUT LIMITATION, THE IMPLIED WARRANTY OF MERCHANTABILITY AND FITNESS FOR A PARTICULAR PURPOSE TO THE ONE (1) YEAR TERM OF THIS LIMITED WARRANTY. UPON THE EXPIRATION OF THE ONE (1) YEAR TERM OF THIS LIMITED WARRANTY, VENDOR DISCLAIMS ANY AND ALL IMPLIED WARRANTIES, INCLUDING WITHOUT LIMITATION THE IMPLIED WARRANTIES OF MERCHANTABILITY AND FITNESS FOR A PARTICULAR PURPOSE, THE PRODUCT BEING THUS SOLD AS-IS, WITH ALL FAULTS. FURTHER, VENDOR SHALL HAVE NO LIABILITY WHATSOEVER TO PURCHASER OR ANY THIRD PARTY FOR ANY SPECIAL, INDIRECT, PUNITIVE, INCIDENTAL, OR CONSEQUENTIAL DAMAGES. OTHER THAN THIS LIMITED WARRANTY, THERE ARE NO WARRANTIES WHICH EXTEND BEYOND THE DESCRIPTION ON THE FACE HEREOF. Vendor assumes no responsibility for any defects caused by third parties. This Limited Warranty gives you specific legal rights, and you may have other rights which vary from state to state. State law may also override statements in this Limited Warranty regarding the restriction on the duration of implied warranties. Some jurisdictions do not allow exclusion or limitation of special, incidental or consequential damages, or limitations on how long a warranty lasts, so the above exclusion and limitations may not apply to you.

Brio[®]

WWW.BRIOWATER.COM

©2024 Brio Water Technology, Inc.