



Brio[®]

430

BOTTOM LOAD WATER DISPENSER

Setup Manual

Model No.: CLBL430SC

Table of Contents

Safety Information	3
Intended Use	4
Product Features	4
Indicator Panel Description	5
Operational Specifications	5
Technical Specifications	5
Installation	6
Determine Installation Location	6
Install the Drip Tray and Grid	6
Connect a Water Bottle	7
Operation	8
Turn on Heating and Cooling Switches	8
Dispense Cold Water	8
Disable Child Safety Lock and Dispense Hot Water	8
Change the Water Bottle	9
Troubleshooting	9
Care and Maintenance	9
Clean the Reservoirs	10
Warranty	11

Safety Information

WARNING: To reduce risk of injury and property damage, you must read this entire guide before assembling, installing and operating the dispenser.

WARNING: This product dispenses water at very high temperatures. Failure to use properly can cause personal injury. When operating this dispenser, always exercise basic safety precautions, including the following:

- Prior to use, this dispenser must be properly assembled and installed in accordance with this manual.
- For indoor use only. Keep the water dispenser in a dry place away from direct sunlight. Do NOT use outdoors.
- Install and use only on a hard, flat and level surface.
- Do NOT place the water dispenser in an enclosed space or cabinet.
- Do NOT operate the dispenser in the presence of explosive fumes.
- Use only properly grounded outlets.
- Do not use an extension cord.
- Always grasp the plug and pull straight out from the outlet. Never unplug by pulling on the power cord.
- Do NOT use the dispenser if the cord becomes frayed or otherwise damaged. If the supply cord is damaged, it must be replaced by the manufacturer, its service agent or similarly qualified persons in order to avoid a hazard.
- To protect against electric shock, do NOT immerse cord, plug, or any other part of the dispenser in water or other liquids.
- Do not use this dispenser with water that is microbiologically unsafe or of unknown quality.
- Water dispenser is compatible with 5-gallon (19-liter) water bottles.
- Clean up all water spills after loading or unloading water bottles from the dispenser.
- Ensure the water dispenser is unplugged prior to cleaning.
- Never allow children to dispense hot water without proper and direct supervision. Unplug the unit to prevent unsupervised use by children.
- Service should be performed only by a certified technician.
- The appliance must not be cleaned by a water jet and is not suitable for installation in an area where a water jet could be used.

WARNING: Keep ventilation openings, in the dispenser enclosure or in the built-in structure, clear of obstruction.

WARNING: Do not use mechanical devices or other means to accelerate the defrosting process, other than those recommended by the manufacturer.

- Never turn the dispenser upside down or lean it more than 45°.
- After turning the dispenser off, allow the dispenser to sit idle for 3 minutes before turning on again.

Intended Use

This dispenser is intended to be used in household and similar applications such as:

- Staff kitchen areas in shops, offices and other working environments
- Farm houses
- Hotels, motels and other residential-type environments
- Bed-and-breakfast type environments
- Catering and similar non-retail applications

This dispenser is not intended for use by persons (including children) with reduced physical, sensory or mental capabilities, or lack of experience and knowledge, unless they have been given supervision or instruction concerning use of the appliance by a person responsible for their safety.

Product Features

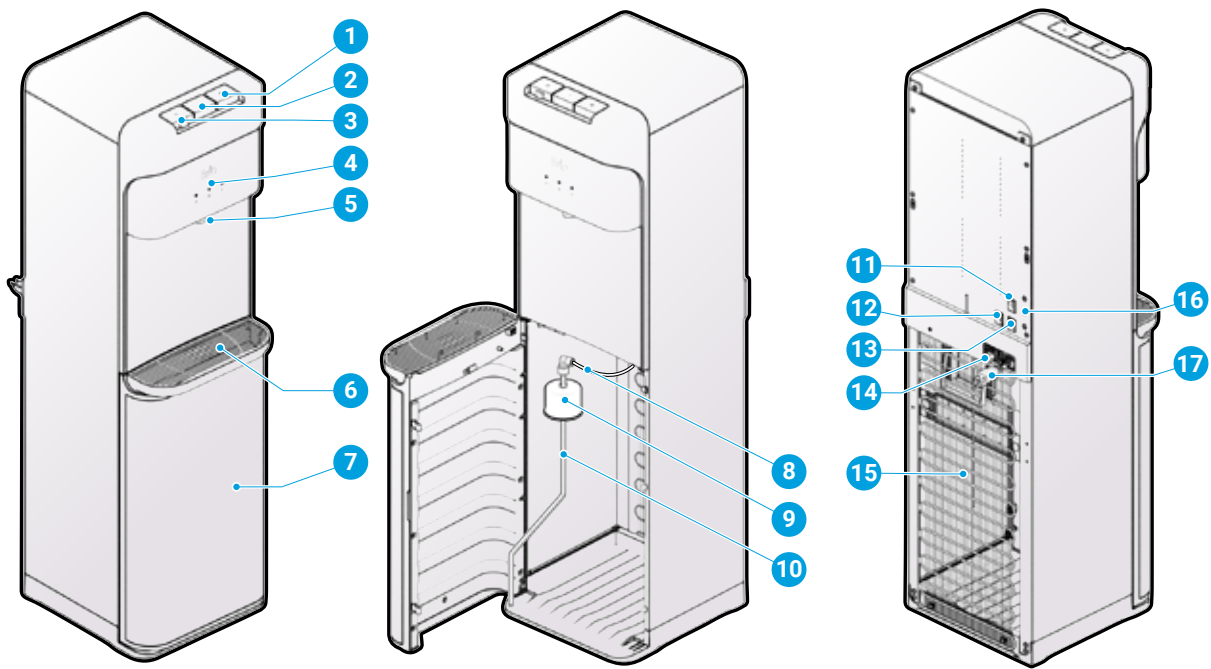

Part	Description
1	Cold water button
2	Room temperature water button
3	Hot water button
4	Indicator panel
5	Water tap
6	Drip tray
7	Water bottle cabinet
8	Water line
9	Bottle cap

Part	Description
10	Bottle tube
11	Heating switch
12	Night light switch
13	Cooling switch
14	Drain outlet
15	Condenser
16	Cold water thermostat
17	Power cord

Indicator Panel Description

1. Hot water indicator light - When illuminated, indicates that the dispenser is heating water.
2. Cold water indicator light - When illuminated, indicates that the dispenser is cooling water.
3. Change-bottle indicator light – When flashing, indicates water bottle is empty and needs to be replaced with a new water bottle.

Brio[®]

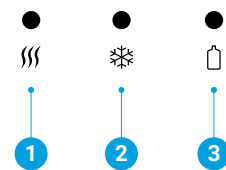

Operational Specifications

You must use the dispenser within the following operational parameters to ensure safe, optimal performance.

Model No.	CLBL430SC
Rated Voltage / Frequency	115 V ~ 60 Hz
Heating Power	450 W
Cooling Power	85 W
Operating Ambient Temperature	39–100 °F (4–38 °C)
Operating Humidity	≤90%

Technical Specifications

CAUTION: This unit dispenses water at temperatures that can cause severe burns. Avoid direct contact with hot water. Keep children and pets away from unit while dispensing. Never allow children to dispense hot water without proper and direct supervision. Unplug unit to prevent unsupervised use by children.

Model No.	CLBL430SC
Cold Water Tank Volume	3.7 L
Hot Water Tank Volume	1.0 L
Hot Water Capacity (Measured at Ambient Temperature of 77 °F / 25 °C)	7.5 L/h (≥165 °F / 73.9 °C)
Cold Water Capacity (Measured at Ambient Temperature of 77 °F / 25 °C)	2.2 L/h (≤50 °F / 10 °C)
Hot Water Flow Rate	≥1.5 L/min
Cold Water Flow Rate	≥2.7 L/min
Ambient Water Flow Rate	≥2.7 L/min
Net Weight	36.6 lb (16.6 kg)
Product Dimensions (WxHxD)	11.81 x 41.73 x 14.17 in. (30 x 104 x 34 cm)
Water Dispense Point to Water Drip Tray (H)	10.5 in. (26.67 cm)
Water Drip Tray Dimensions (WxD)	11.22 x 3.82 in. (28.5 x 9.7 cm)
Noise (dBA)	≤55 dB

Installation

1. Determine Installation Location

IMPORTANT: If the dispenser has been resting on its side for a long period of time, place it in the upright position for approximately 12 hours before installing.

- A. Locate the dispenser on a hard and level surface in a cool shaded location near a grounded wall outlet.
- B. Position the back of the dispenser no closer than 8 in. (20 cm) from wall to permit free airflow between the wall and water dispenser.

2. Install the Drip Tray and Grid

- A. Unwrap drip tray and grid (6) from the packaging material and slide it onto the dispenser until it is securely in place.

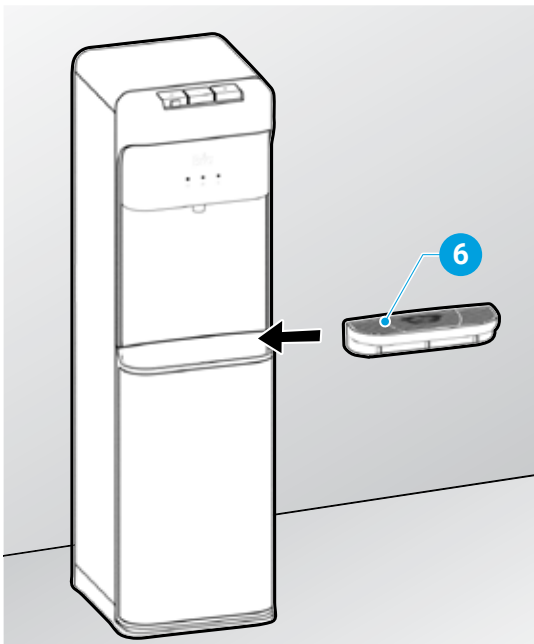

3. Connect a Water Bottle

IMPORTANT: To prevent dry heating, DO NOT turn on the heating and cooling switches until you complete the steps in this procedure.

NOTE: The dispenser is compatible with 5-gallon water bottles only.

- A. Remove the plastic wrapping and cap from a new 5-gallon bottle of water (purchased separately).
- B. Open the cabinet door and feed the bottle adapter tube (10) into the water bottle. Ensure the tube hits the bottom of the bottle.
- C. Fit the bottle cap (9) over the neck of the water bottle and press securely into place.

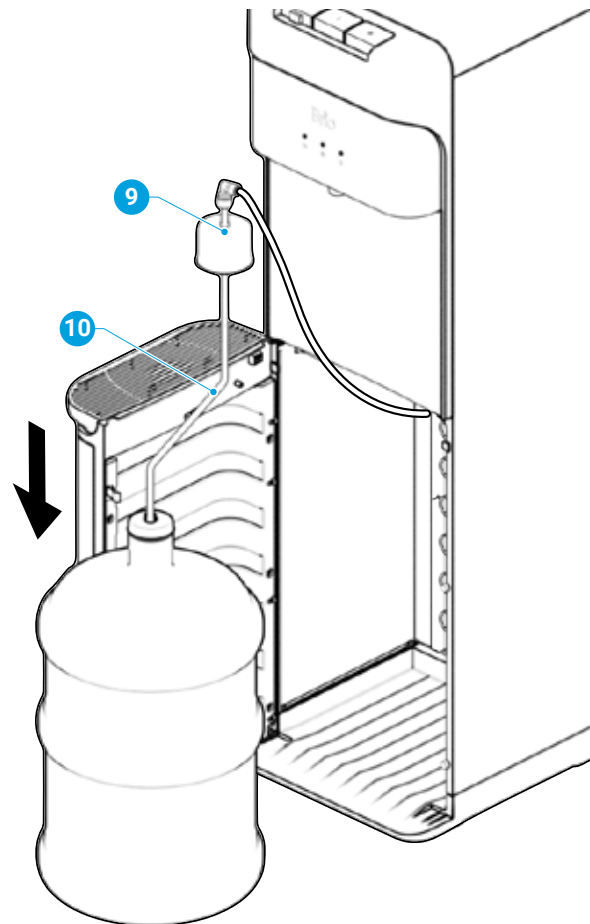

- D. Slide the water bottle into the dispenser cabinet and close the door. Plug in dispenser.

NOTE: Water will not pump from bottle unless door is completely closed.

- E. Wait 5 minutes for tanks to fill. Place a container under the dispense point. Press hot and cold water buttons until water dispenses steadily and without air. We advise dispensing and disposing of at least 1 quart of water.

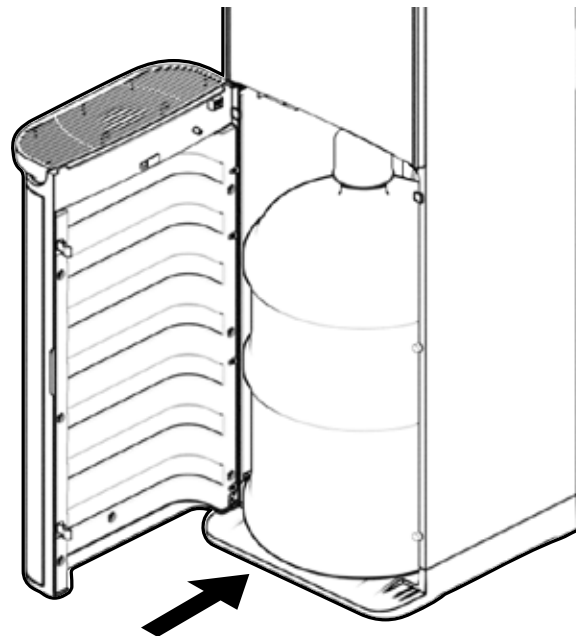

Operation

IMPORTANT: This unit has been tested and sanitized prior to packing and shipping. During transit, dust and odors can accumulate in the tank and lines. Dispense and dispose at least one quart of water prior to drinking any water.

Turn on Heating and Cooling Switches

IMPORTANT: Before you activate the heating and cooling switches, ensure a full bottle of water is installed and tanks have been filled.

1. To power on the cooling system, flip the cooling switch to the On position. It takes approximately 1 hour after turning on the cooling switch for the cold water to reach its coldest temperature. During the cooling process, the cold water indicator light will remain illuminated. Once the cold water has reached its coldest temperature, the cold water indicator light will turn off.
2. To power on the heating system, flip the heating switch to the On position. It takes approximately 15 to 20 minutes after turning on the heating switch for hot water to reach its hottest temperature. During the heating process, the hot water indicator light will remain illuminated. Once the hot water has reached its hottest temperature, the hot water indicator light will turn off.

Dispense Cold Water

1. Place a drinking glass or container under the tap and press cold water button to dispense cold water.
2. Release when your container is full.

Adjust the Cold Water Thermostat

The cold water reservoir temperature is monitored by a cold water thermostat (16) located at the rear of the dispenser. Using a screwdriver, turn the set screw clockwise between the lower setting for warmer water and higher setting for colder water until the desired temperature is reached. If water is not being properly dispensed, there could be possible ice build-up in the reservoir due to the thermostat being set too cold. If this happens, slowly rotate the thermostat set screw counterclockwise to a warmer setting.

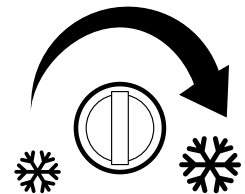

Disable Child Safety Lock and Dispense Hot Water

CAUTION: This unit dispenses water at temperatures that can cause severe burns. Avoid direct contact with hot water. Keep children and pets away from the unit while dispensing. Never allow children to dispense hot water without proper and direct supervision. Disable the heating feature by switching the heating switch to the Off position.

1. This water dispenser is equipped with a child safety feature in order to prevent inadvertent dispensing. To enable dispensing of hot water, place a cup or container under the tap. Simultaneously press in the red lock button on the front of the hot water button while pressing the hot water button down.
2. Release the red lock button and hot water button once your container is full. Hot water will automatically relock.

Change the Water Bottle

CAUTION: Do not dispense water if the red change-bottle indicator light is flashing as you could empty the tanks and cause the dispenser to overheat.

When the change-bottle indicator light on the front of the dispenser flashes red, it is time to replace your empty water bottle with a new water bottle:

1. Open the dispenser cabinet door and slide the empty bottle out of the cabinet.
2. Remove the bottle adapter from the empty bottle and let the probe drip into the bottle. Once dripping has stopped, place the bottle adapter on the hanger and set the empty bottle aside.
3. Follow the steps in **Connect a Water Bottle** to install your new water bottle.
4. Recycle the empty bottle at your local exchange center to receive your next bottle at a discount.

Troubleshooting

Problem	Solution
The cold water is not cold.	<ul style="list-style-type: none">• It takes up to one hour after setup to dispense cold water.• Make sure the power cord is properly connected to a working outlet.• Make sure the back of the dispenser is at least 8 inches from wall and there is free airflow on all sides of the dispenser.• Make sure green power switch on back of dispenser is On.• Using a screwdriver, turn the cold water thermostat set screw clockwise (to the right) until desired temperature is reached.
The hot water is not hot.	<ul style="list-style-type: none">• It takes 15-20 minutes after setup to dispense hot water.• Make sure the power cord is properly connected to a working outlet.• Make sure red heating switch on back of dispenser is On.
The dispenser is noisy.	<ul style="list-style-type: none">• Ensure the dispenser is located on a level surface.• The heating tube may be generating a slight noise. This is normal.
The bottle is leaking.	<ul style="list-style-type: none">• Ensure the bottle is installed correctly.• Check to see if the bottle is cracked or broken. If so, replace the bottle.
The dispenser is not dispensing water.	<ul style="list-style-type: none">• Check to see if the bottle is empty and replace with a new bottle if necessary.• There may still be air in the tank. Press and hold water buttons to remove air until water begins to flow.

Care and Maintenance

- Keep this dispenser in a dry and cool place and avoid direct sunshine.
- Ensure the back of the dispenser is at least 8 in, (20 cm) away from the wall.
- Never put the dispenser on paper or foam, which may store water and then cause creepage. Never put anything flammable beside this machine.
- Do not use the dispenser outdoors or in a place that can be splashed by water.
- If the dispenser is not in use for longer than a 24-hour period, turn off the heating and cooling switches to save power and drain any remaining water.
- Clean your cabinet, controls, bottle probe and spout each time you change your water bottle. Use a clean soft cloth and a food grade sanitizer or bleach.
- Empty and clean the drip tray as needed.

Clean the Reservoirs

The reservoirs should be cleaned every 3 to 4 months to remove mineral buildup and optimize dispenser performance.

Gather the following supplies:

- 200g (approx. 1.5 cups) citric acid crystals
- Hot water
- Large bucket or empty 5-gallon bottle
- Container or cup
- Clean dry cloth

- A.** Turn the heating and cooling switches to the OFF position, and unplug the dispenser.
- B.** Remove the water bottle, then move the dispenser away from the wall to gain access to the back.
- C.** Drain remaining water from the reservoirs by dispensing from tap into a container.
- D.** Pour citric acid crystals, then 2 gallons of hot water into the 5-gallon bottle or bucket. Stir or agitate briefly to mix.

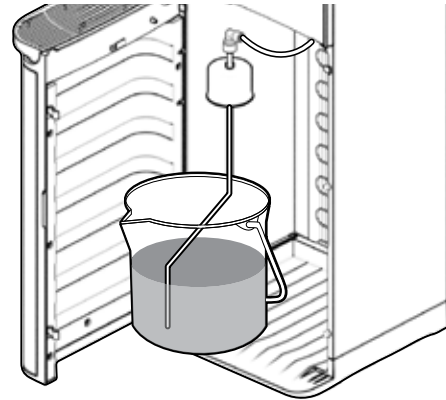

- E.** Insert the bottle adapter tube into the bottle or bucket with the solution, secure the cap if using a bottle, and slide into dispenser, shutting door securely.

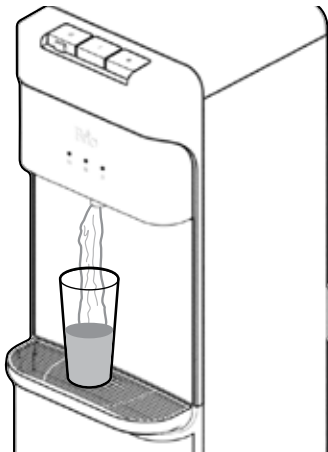

- F.** Plug the dispenser back in and allow the cleaning solution to fill the reservoirs. Then dispense a small amount of the solution from tap into the cup or container.
- G.** Wait 20 minutes, unplug the dispenser, then drain the reservoirs as described in step C. Rinse out the solution bottle or bucket, then fill with 2 gallons of fresh hot tap water and repeat process described in step E. Allow reservoirs to fill. (Don't forget to shut door and plug in dispenser.)

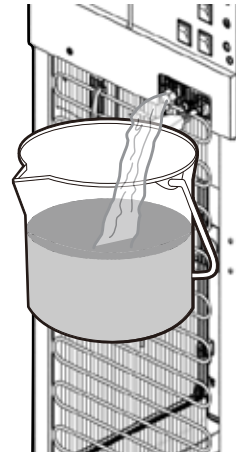

- H.** Unplug dispenser and place a 3-gallon bucket at the back of the dispenser. Remove the drain plug while simultaneously pressing the dispense buttons. Once reservoirs have been drained, replace drain plug.
- I.** Return dispenser to its location, install a fresh bottle of water, plug in power cord, allow reservoirs to fill, and turn heating and cooling switches ON.
- J.** If any odor or taste persists after cleaning, repeat the above steps using 2 cups of white vinegar and 2 gallons of water.

Warranty

Brio (“Vendor”) warrants to the original purchaser of the Brio Water Coolers (the “Product”), and to no other person, that if the Product is assembled and operated in accordance with the printed instructions accompanying it, then for a period of one (1) year from the date of purchase, all parts in the Product shall be free from defects in material and workmanship. This Limited Warranty shall be limited to repair or replacement of parts, which prove defective under normal use and service and which Vendor shall determine in its reasonable discretion upon examination to be defective. To take advantage of this Limited Warranty, please follow these steps:

1. Please retain your sales slip or invoice, as Vendor may require reasonable proof of your date of purchase.
2. Contact Vendor’s Customer Service Department using the contact information listed below.
3. Return parts to Vendor, per Vendor’s instructions, at your cost and expense.
4. Upon receipt by Vendor, Vendor shall advise you in writing whether a defect covered by this Limited Warranty exists in any returned part and whether your claim has been approved or denied.
5. Upon Vendor’s approval of your claim, Vendor will replace such defective part without charge to you.

WHAT THIS LIMITED WARRANTY DOES NOT COVER: This Limited Warranty does not cover any failures or operating difficulties of the Product due to accident, abuse, misuse, alteration, misapplication, improper installation or improper maintenance or service by you or any third party, or failure to perform normal and routine maintenance on the Product, as set out in the User’s Manual. In addition, this Limited Warranty does not cover damages to the finish, such as scratches, dents, discoloration or rust after purchase.

This Limited Warranty is the only express warranty given on the Product and is in lieu of all other express warranties. Vendor disclaims all warranties for products that are purchased from seller other than authorized retailers or distributors. THIS LIMITED WARRANTY RESTRICTS THE DURATION OF ANY AND ALL IMPLIED WARRANTIES, INCLUDING WITHOUT LIMITATION, THE IMPLIED WARRANTY OF MERCHANTABILITY AND FITNESS FOR A PARTICULAR PURPOSE TO THE ONE (1) YEAR TERM OF THIS LIMITED WARRANTY. UPON THE EXPIRATION OF THE ONE (1) YEAR TERM OF THIS LIMITED WARRANTY, VENDOR DISCLAIMS ANY AND ALL IMPLIED WARRANTIES, INCLUDING WITHOUT LIMITATION THE IMPLIED WARRANTIES OF MERCHANTABILITY AND FITNESS FOR A PARTICULAR PURPOSE, THE PRODUCT BEING THUS SOLD AS-IS, WITH ALL FAULTS. FURTHER, VENDOR SHALL HAVE NO LIABILITY WHATSOEVER TO PURCHASER OR ANY THIRD PARTY FOR ANY SPECIAL, INDIRECT, PUNITIVE, INCIDENTAL, OR CONSEQUENTIAL DAMAGES. OTHER THAN THIS LIMITED WARRANTY, THERE ARE NO WARRANTIES WHICH EXTEND BEYOND THE DESCRIPTION ON THE FACE HEREOF. Vendor assumes no responsibility for any defects caused by third parties. This Limited Warranty gives you specific legal rights, and you may have other rights which vary from state to state. State law may also override statements in this Limited Warranty regarding the restriction on the duration of implied warranties. Some jurisdictions do not allow exclusion or limitation of special, incidental or consequential damages, or limitations on how long a warranty lasts, so the above exclusion and limitations may not apply to you.

Brio[®]

WWW.BRIOWATER.COM

©2024 Brio Water Technology, Inc.