

Brio®



Moderna™

**Point of Use
Water Dispenser**

Setup Manual

Model No.: CLPOU720UVRO4

Table of Contents

Safety Information	3
Intended Use	3
Product Features	4
Product Dimensions	4
Operational Specifications	4
Touch Panel Description	5
TDS Reduction Rates	5
Package Contents	6
Materials Needed	6
Installation	7
Determine Installation Location	7
Connect to the Cold Water Supply	7
Make the Reverse Osmosis Waste Connections	8
Flush the Filters	9
Install the Filters and Complete the Installation	10
Operation	11
Turn the Dispenser On/Off	11
Set the Time	11
Set the Cold Water Temperature Level	11
Set the Hot Water Temperature Level	12
Dispense Cold Water	12
Disable Child Safety Lock and Dispense Hot Water	12
Troubleshooting	13
Cleaning and Maintenance	13
Care and Maintenance	13
Filter Replacement Schedule	14
Replace the Filters	14
Filter Specifications	14
Warranty	15

Safety Information

WARNING: To reduce risk of injury and property damage, you must read this entire guide before assembling, installing and operating the dispenser.

WARNING: This product dispenses water at very high temperatures. Failure to use properly can cause personal injury. When operating this dispenser, always exercise basic safety precautions, including the following:

- Prior to use, this dispenser must be properly assembled and installed in accordance with this manual.
- For indoor use only. Keep the water dispenser in a dry place away from direct sunlight. Do NOT use outdoors.
- Install and use only on a hard, flat and level surface.
- Do NOT place the water dispenser in an enclosed space or cabinet.
- Do NOT operate the dispenser in the presence of explosive fumes.
- Use only properly grounded outlets.
- Do not use an extension cord.
- Always grasp the plug and pull straight out from the outlet. Never unplug by pulling on the power cord.
- Do NOT use the dispenser if the cord becomes frayed or otherwise damaged. If the supply cord is damaged, it must be replaced by the manufacturer, its service agent or similarly qualified persons in order to avoid a hazard.
- To protect against electric shock, do NOT immerse cord, plug, or any other part of the dispenser in water or other liquids.
- Ensure the water dispenser is unplugged prior to cleaning.
- Never allow children to dispense hot water without proper and direct supervision. Unplug the unit to prevent unsupervised use by children.
- Service should be performed only by a certified technician.
- The appliance must not be cleaned by a water jet and is not suitable for installation in an area where a water jet could be used.

WARNING: Keep ventilation openings, in the appliance enclosure or in the built-in structure, clear of obstruction.

WARNING: Do not use mechanical devices or other means to accelerate the defrosting process, other than those recommended by the manufacturer.

- This appliance should work under environment of temperatures from 4°C~40°C (39°F~104°F) and humidity ≤90%.
- Never turn the machine upside down or lean it more than 45°.
- After turning the dispenser off, allow the dispenser to sit idle for 3 minutes before turning on again.

WARNING: UV light source. Disconnect the electrical supply to the UV radiation BEFORE opening cover.

- UV-LED lamp must be repaired by manufacturer only.
- UV-LED lamp model no. YB09-950-022, rated DC 24V, 0.17W±20%.
- Disposal of the UV-LED lamp must be done in accordance with local laws and regulations.

Intended Use

This appliance is intended to be used in household and similar applications such as:

- Staff kitchen areas in shops, offices and other working environments
- Farm houses
- Hotels, motels and other residential-type environments
- Bed-and-breakfast environments
- Catering and similar non-retail applications

This appliance is not intended for use by persons (including children) with reduced physical, sensory or mental capabilities, or lack of experience and knowledge, unless they have been given supervision or instruction concerning use of the appliance by a person responsible for their safety.

Product Features

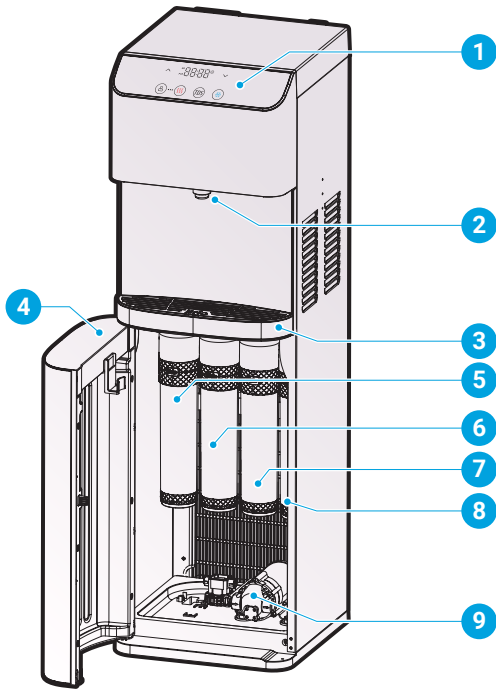

Part	Description
1	Touch panel display
2	Water tap
3	Drip tray
4	Filter cabinet
5	Sediment filter
6	Pre carbon filter
7	Reverse osmosis (RO) filter
8	Post carbon filter

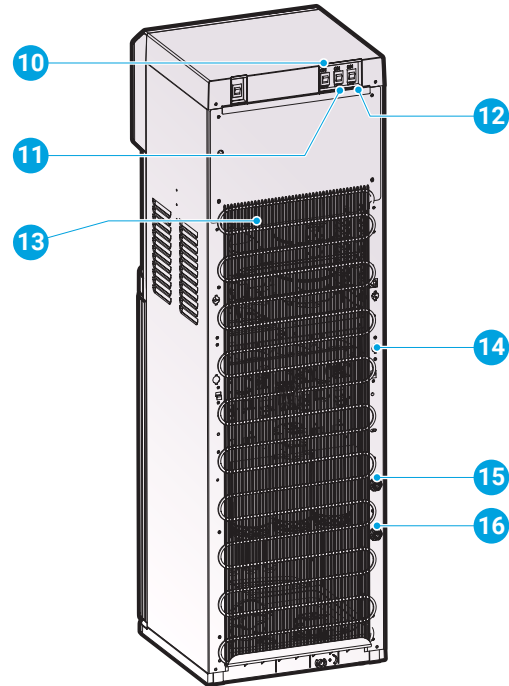

Part	Description
9	RO pump
10	Night light switch
11	Cold water switch
12	Hot water switch
13	Condenser
14	Drain outlet
15	RO water inlet
16	Water outlet

Product Dimensions

Height	Width	Depth
41.1 in. (104.4 cm)	12.2 in. (31.1 cm)	14 in. (35.4 cm)

Operational Specifications

CAUTION: This unit dispenses water at temperatures that can cause severe burns. Avoid direct contact with hot water. Keep children and pets away from unit while dispensing. Never allow children to dispense hot water without proper and direct supervision. Unplug unit to prevent unsupervised use by children.

	Temperature	Tank Volume	Tank Capacity	Flow Rate
Cold Water	39°F-59°F / 4°C-15°C	3.6 L	2.5 L/h	1.2 L/min
Hot Water	174°F-194°F / 79°C-90°C	1 L	4 L/h	1.2 L/min

Touch Panel Description

No.	Description
1	Up arrow button
2	Change PCB filter icon
3	Change RO filter icon
4	LED display
5	Self-cleaning UV icon
6	Down arrow button
7	Lock button
8	Hot water button
9	TDS button
10	Cold water button

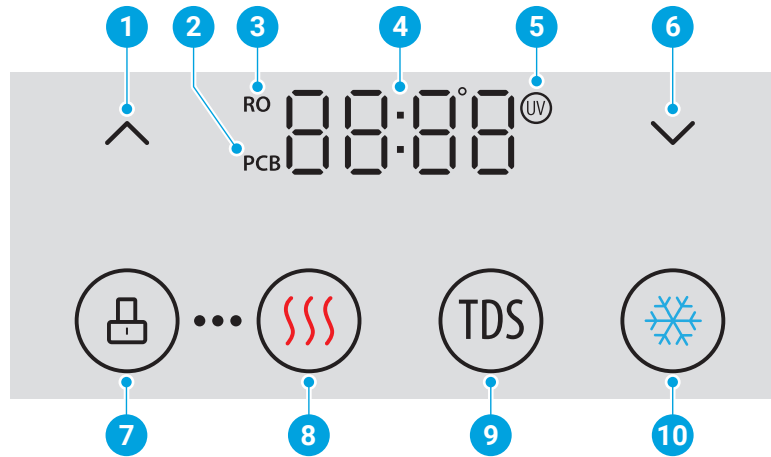

TDS Reduction Rates

Dispensed water should see a TDS reduction rate of up to 90%. Refer to the following table for estimated before and after TDS levels.

NOTE: TDS reduction rates may vary based on the quality of source water.

Inlet Water TDS Level	Dispensed Water TDS Level
650	65
600	60
550	55
500	50
450	45
400	40
350	35
300	30
250	25
200	20
150	15
100	10
50	5

Package Contents

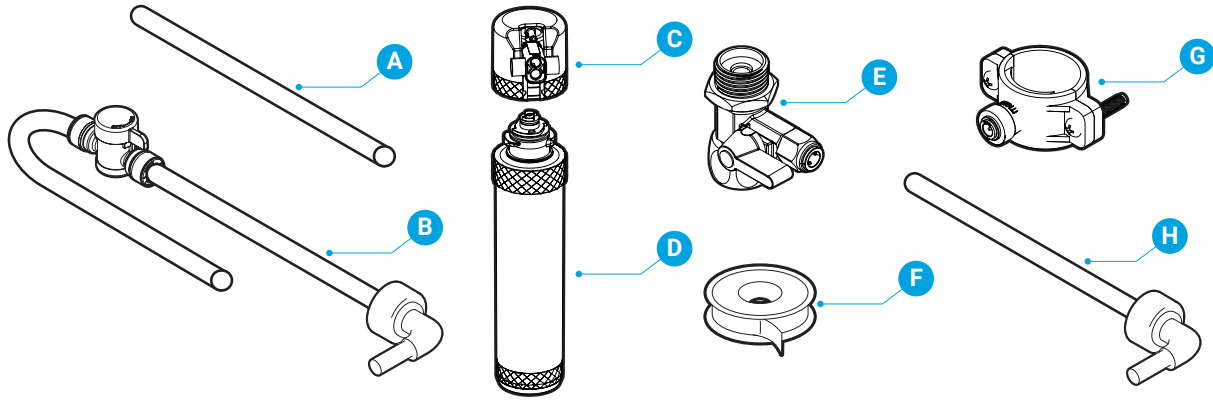

Part	Description	Quantity
A	Filter flushing tube	1
B	Shut-off valve tube (7 ft.)	1
C	Filter housing (for filter flushing)	1
D	Filters	4

Part	Description	Quantity
E	Feed water adapter (with extra nut)	1
F	Plumber's tape	1
G	Drain saddle with foam gasket	1
H	RO water outlet tube	1

Materials Needed

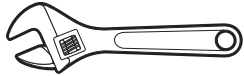

Wrench

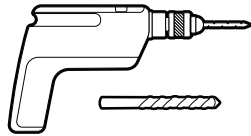

Electric drill with 1/4 in. drill bit

Installation

1. Determine Installation Location

- A. Place the dispenser upright.
- B. Locate the dispenser on a hard and level surface in a cool shaded location near a grounded wall outlet.
NOTICE: Do NOT plug in the power cord until the entire installation section is completed.
- C. Position the back of the dispenser no closer than 8 in. (20 cm) from a wall and permit free airflow between the wall and water dispenser.

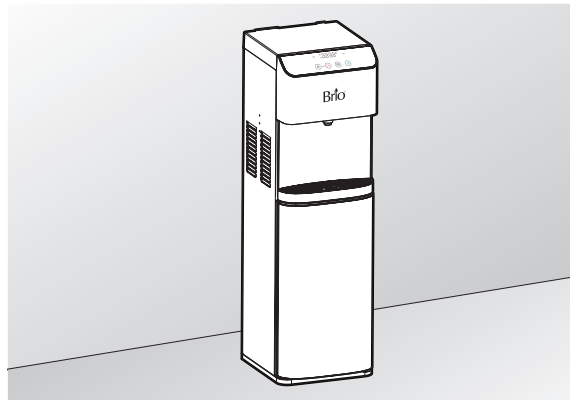

2. Connect to the Cold Water Supply

CAUTION: DO NOT CONNECT THIS WATER LINE TO A HOT WATER SUPPLY LINE. The water supply to the unit MUST be from the COLD WATER LINE. Using HOT WATER will severely damage your filters.

- A. Turn off the cold water supply, then disconnect the cold water pipe from the cold water supply line.
- B. Connect the feedwater adapter (E) to the cold water supply line.
- C. Connect the cold water pipe to the top of the feedwater adapter (E).

NOTE: An extra adapter nut is included on top of the feed water adapter (E) to attach to a 3/8 in. or 1/2 in. feed plumbing line.

- D. Insert the shut-off valve with tube (B) straight into the quick connector piece of the feedwater adapter (E).

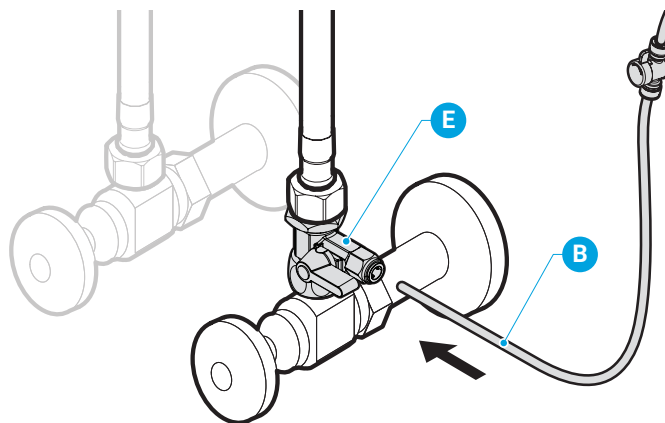
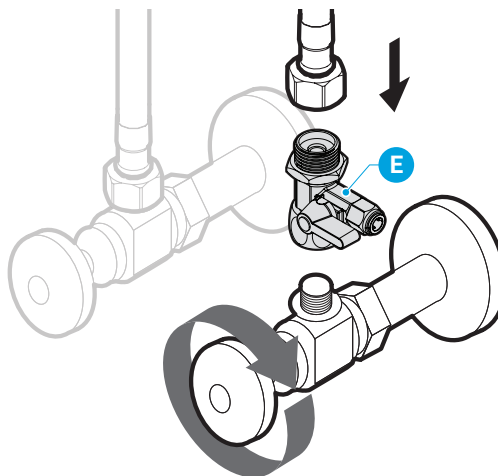

- E. Gently tug on the tube (B) to ensure a secure connection with the feed water adapter (E).

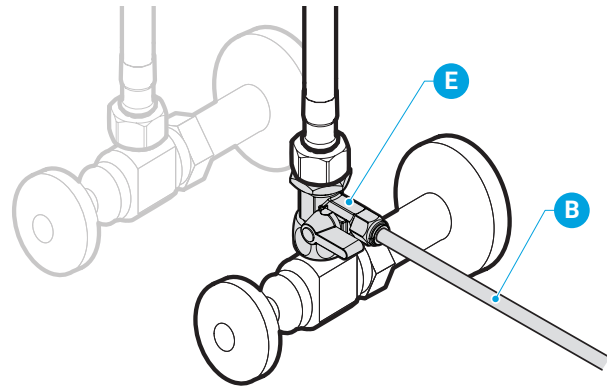

3. Make the Reverse Osmosis Waste Connections

The “RO” filter assembly requires a drain line connection to be installed, which removes rejected water to the sewer. The drain saddle connects the drain line from the dispenser to your drain pipe. The drain saddle is designed to fit around a standard 1.5 in. OD (outer diameter) drain pipe.

- ✓ Always install the drain saddle before the P-trap and on a straight vertical or horizontal section of the pipe.
- ✗ To avoid clogging the drain line with debris, do not install the drain saddle after the drain pipe meets a garbage disposal or dishwasher drain.

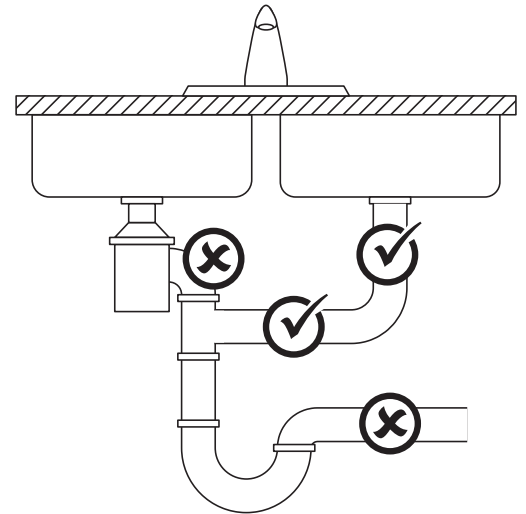

To make the Reverse Osmosis (RO) drain connections:

- A. Determine the location for your drain saddle (G) and then make a mark on the drain pipe for the opening (1).
- B. Use your drill and a 1/4 in. drill bit to drill a hole at the mark, ensuring you only drill through one side of the drain pipe.
- C. Find the half of the drain saddle (G) with the hole in the center, remove the backing from the foam gasket, align the gasket with the hole on the drain saddle (G), and stick the adhesive side of the gasket to the drain saddle (G).
- D. Position both halves of the drain saddle (G) on the drain pipe with the saddle’s opening aligned over the drilled hole, and insert your drill bit through the saddle (G) and drilled hole to ensure proper alignment.
- E. Secure both ends of the drain saddle (G) together using the bolts and nuts, but do not over-tighten.
- F. Connect the RO water outlet tube (H) to the drain saddle (G). To prevent water leakage, ensure the RO water outlet tube (H) has been placed 0.6 inches in the pipe.

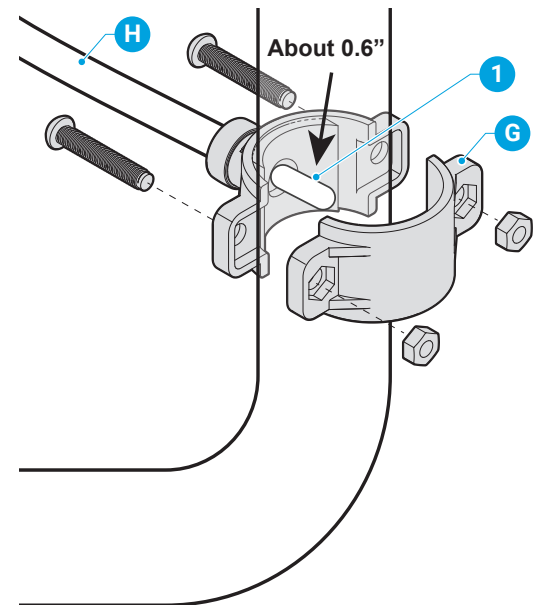

4. Flush the Filters

Follow this procedure each time you replace your filters.

IMPORTANT: Ensure water supply is off before you begin.

IMPORTANT: Flush ONLY the sediment, pre carbon, and post carbon filters. The reverse osmosis (RO) filter should not be flushed.

- A. Connect a filter (D) to the filter housing (C) by twisting the filter (D) clockwise.

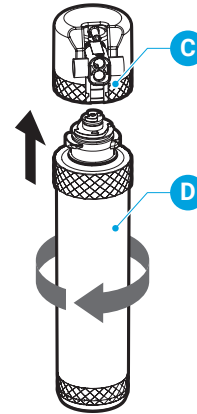

- B. Connect the tip of the shut-off valve tube (B) to the left side of the filter housing (C).

- C. Connect the filter flushing tube (A) to the right side of the filter housing (C) and lay the open end of the filter flushing tube (A) over a sink or receptacle to collect water.

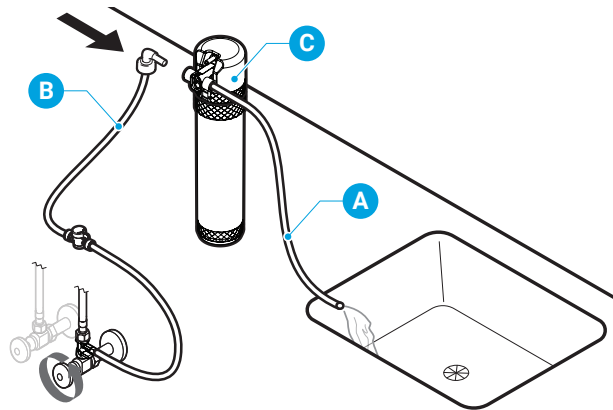

- D. Turn on valve at water source. Flush each filter for a minimum of 5 minutes. The recommended rate is 1.5-3 gallons of water (about 10 minutes) or until the water is clear in appearance.

- E. Shut off the valve at the water source and remove the filter housing from the tube (B).

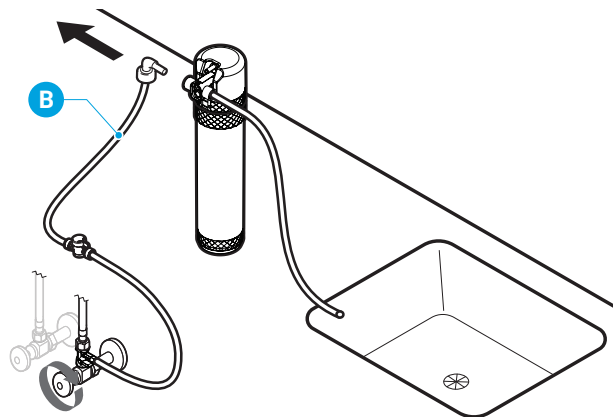

5. Install the Filters and Complete the Installation

- A. After flushing, twist each filter (D) clockwise into the filter housings located inside the dispenser cabinet. The sediment filter goes on the left, followed by the carbon, RO, and post carbon filter.

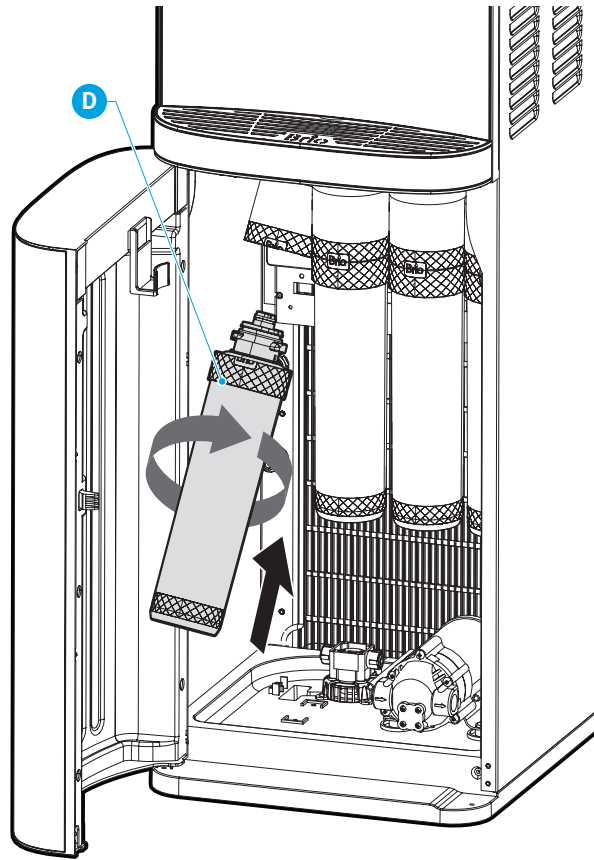

- B. Remove the safety plug from the water inlet hole on the back of the dispenser by pushing in the inlet hole collar and then gently pulling out the plug.
- C. Connect the RO water outlet tube (H) from the RO drain saddle (G) to the RO water outlet.
- D. Connect the tip of the shut-off valve tube (B) into the water inlet hole on the back of the dispenser. Then turn on the main water supply and ensure the valve in the tube (B) is on.

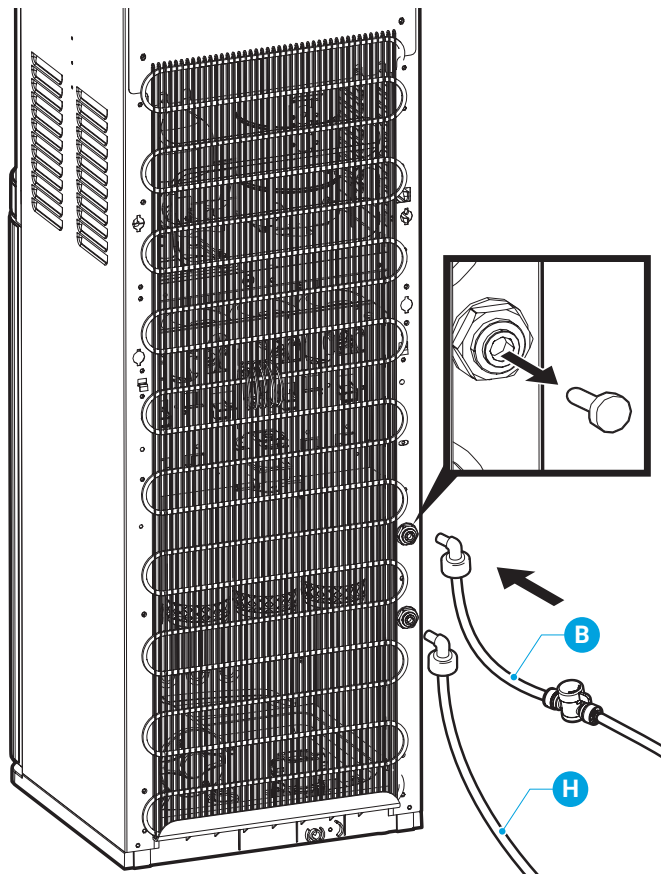

Operation

IMPORTANT: This unit has been tested and sanitized prior to packing and shipping. During transit, dust and odors can accumulate in the tank and lines. Dispense and dispose at least one quart of water prior to drinking any water.

Turn the Dispenser On/Off

IMPORTANT: Before you activate the hot and cold switches, ensure water has filled the tanks inside the dispenser in order to prevent dry heating.

1. Plug in the dispenser.
2. Run water through the cold and hot water taps until water begins to dispense.
3. To power on the cooling system, flip the cooling switch on the back of the dispenser to the On position. The cold water button on the front of the dispenser illuminates in blue indicating the dispenser is cooling water. The light changes to white when the cooling process is complete.
4. To power on the heating system, flip the heating switch on the back of the dispenser to the On position. The hot water button on the front of the dispenser illuminates in red indicating that the dispenser is heating water. The light changes to white when the heating process is complete.

Set the Time

1. Press and hold the up and down arrow buttons for 3 seconds until the clock display begins to blink.
2. Press the cold water button to set the minute and the hot water button to set the hour. Use the up and down arrow buttons to scroll until the correct minute/hour is displayed.
3. Press the lock button until the selected time stops blinking. The time is now set.

Set the Cold Water Temperature Level

You can select from 3 different cold water dispensing temperature levels: C1 (cold), C2 (colder), and C3 (coldest).

Temperature Level	Dispensing Temperature Range
C1	49°F to 55°F
C2	43°F to 49°F
C3	37°F to 43°F

NOTE: The default temperature dispensing level for cold water is C3 (coldest).

To change the cold water temperature dispensing level, please do the following:

1. Simultaneously press and hold the lock and cold water buttons for 3 seconds. The cold water button and LED display showing current cold water temperature level begin to flash.
2. Press the up or down arrow to scroll through the 3 options. They will be displayed as C1, C2, and C3. After you have reached the desired temperature level, quickly press the lock button. The new level is now set. It takes approximately 2 hours for the cold water temperature range to adjust to the new level. During the adjustment process, the cold water light will illuminate in blue. Once the new level has been reached, the light will change to white.

NOTE: Cold water temperature is measured inside cold reservoir tank. Due to many variables, including but not limited to, ambient temperature, water receptacle size/temperature, internal travel from reservoir tank to dispense point, etc., temperature range of water dispensed will vary from stated range.

Set the Hot Water Temperature Level

You can select from 3 different hot water dispensing temperature levels: H1 (hot), H2 (hotter), and H3 (hottest).

Temperature Level	Dispensing Temperature Range
H1	178°F to 184°F
H2	184°F to 190°F
H3	190°F to 196°F

NOTE: The default temperature dispensing level for hot water is H3 (hottest).

To change the hot water temperature dispensing level, please do the following:

1. Simultaneously press and hold the lock and hot water buttons for 3 seconds. The hot water button and LED display showing current hot water temperature level being to flash.
2. Press the up or down arrow to scroll through the 3 options. They will be displayed as H1, H2, and H3. After you have reached the desired temperature level, quickly press the lock button. The new level is now set. It takes 15 to 20 minutes for the hot water temperature range to adjust to the new level. During the adjustment process, the hot water light will illuminate in red. Once the new level has been reached, the light will change to white.

NOTE: Hot water temperature is measured inside hot reservoir tank. Due to many variables, including but not limited to, ambient temperature, water receptacle size/temperature, internal travel from reservoir tank to dispense point, etc., temperature range of water dispensed will vary from stated range.

Dispense Cold Water

NOTE: Water will take approximately 1 hour after plugging in and turning on to become completely chilled.

1. Place a drinking glass or container under the tap and press the cold water button to dispense cold water or the ambient water button to dispense room temperature water.
2. Release the button when your container is full.

Disable Child Safety Lock and Dispense Hot Water

CAUTION: This unit dispenses water at temperatures that can cause severe burns. Avoid direct contact with hot water. Keep children and pets away from the unit while dispensing. Never allow children to dispense hot water without proper and direct supervision. Disable the heating feature by switching the heating switch to the Off position.

NOTE: Water will take approximately 15-20 minutes after plugging in and turning on to reach its hottest temperature.

1. This water dispenser is equipped with a child safety feature in order to prevent inadvertent dispensing. To disable the child safety lock feature, press the lock button.
2. To dispense hot water, place a drinking glass or container under the tap and press the hot water button.
3. Release the button when your container is full. Hot water automatically relocks.

Troubleshooting

Problem	Solution
The cold water is not cold.	<ul style="list-style-type: none"> • It takes up to one hour after setup to dispense cold water. • Make sure the power cord is properly connected to a working outlet. • Make sure the back of the dispenser is at least 8 in. (20 cm) from a wall and there is free airflow on all sides of the dispenser. • Make sure green cooling switch on back of dispenser is On. • If water still isn't cold, call customer service at +1 844-257-4103 for assistance.
The hot water is not hot.	<ul style="list-style-type: none"> • It takes 15-20 minutes after setup to dispense hot water. • Make sure the power cord is properly connected to a working outlet. • Make sure red heating switch on back of dispenser is On.
The dispenser is noisy.	<ul style="list-style-type: none"> • Ensure the dispenser is located on a level surface. • The heating tube may be generating a slight noise. This is normal.
There is water leakage.	<p>If the 3 lights are flashing, a leak was detected.</p> <ul style="list-style-type: none"> • The pipe is not connected properly. Check all water connections and tubes to ensure everything is connected properly. • The water and PE pipes have burst. Replace the water and PE pipe.
The machine is not dispensing water.	<ul style="list-style-type: none"> • The dispenser has become too cold and the lines are blocked by ice. Turn the cooling switch off for at least 4 hours to allow the water in the lines to thaw.

Cleaning and Maintenance

The UV icon on the upper-right corner of the display will begin blinking, indicating the cleaning process is underway.

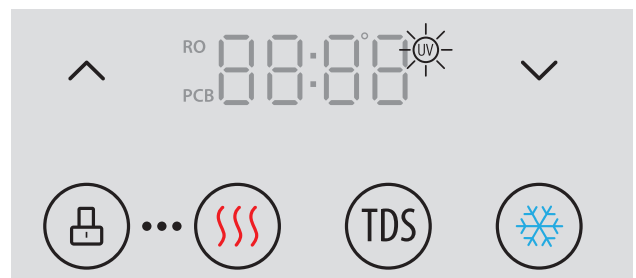

Care and Maintenance

- Keep this dispenser in a dry and cool place and avoid direct sunshine.
- Ensure the back of the dispenser is at least 8 in. (20 cm) away from the wall.
- Never put the dispenser on paper or foam, which may store water and then cause creepage. Never put anything flammable beside this machine.
- Do not use the dispenser outdoors or in a place that can be splashed by water.
- If the dispenser is not in use for longer than a 24-hour period, turn off the heating and cooling switches to save power, and drain any remaining water.
- Empty and clean the drip tray, grid and float as needed.

Filter Replacement Schedule

Filter Type	Model No.	Replacement Schedule	Function
Sediment	NFMPP5M	6–12 months or 3,600 liters	Performs a coarse filtration of original water. Removes mud, sand, iron, rust, suspensions and impurities.
Pre Carbon	NFMGAC	6–12 months or 3,600 liters	Reduces chlorine, taste and odor, lead and cysts.
Reverse Osmosis (RO)	NFMRO75GPD	12–24 months or 7,200 liters	Removes contaminants including arsenic, lead, fluoride, heavy metals and more.
Post Carbon	NFMCTO5MS4	6–12 months or 3,600 liters	Taste and impurity removal.

Replace the Filters

IMPORTANT: Only replace the filters with new filters designed for this dispenser. Any other type of filter will damage the machine and void any warranty.

When the PCB (2) and RO (3) change filter icons steadily illuminate and the dispenser beeps, the filters have expired and must be replaced immediately.

To replace, do the following:

1. Shut off the water supply.
2. To flush your new filters, follow the instructions on page 8, “Flush the Filters.”
3. Remove the old filters and replace with new filters. Ensure the filters are installed as follows, from left to right: sediment filter, pre carbon filter, RO filter, and post carbon filter.
4. After replacing the filter element, press the UP arrow (1) for approximately 3 seconds to reset the filter indicators and turn off the beeping.

Filter Specifications

Sediment Filter

(Sediment, Dirt and Rust Removal)

Filter Capacity	3,600 Liters
Flow Rate	3 LPM
Suggested PSI	14.5 - 58 psi
Temperature	33 - 100 °F

Pre Carbon Filter

(Chlorine, Taste and Odor Reduction)

Filter Capacity	3,600 Liters
Flow Rate	3 LPM
Suggested PSI	14.5 - 58 psi
Temperature	33 - 100 °F

RO Filter

(Reduce Impurities to 0.0001 Microns)

Filter Capacity	7,200 Liters
Flow Rate	0.13 LPM
Suggested PSI	58 - 116 psi
Temperature	33 - 100 °F

Post Carbon Filter

(Final Polish)

Filter Capacity	3,600 Liters
Flow Rate	3 LPM
Suggested PSI	14.5 - 58 psi
Temperature	33 - 100 °F

Warranty

Brio (“Vendor”) warrants to the original purchaser of the Brio Water Coolers (the “Product”), and to no other person, that if the Product is assembled and operated in accordance with the printed instructions accompanying it, then for a period of one (1) year from the date of purchase, all parts in the Product shall be free from defects in material and workmanship. This Limited Warranty shall be limited to repair or replacement of parts, which prove defective under normal use and service and which Vendor shall determine in its reasonable discretion upon examination to be defective. To take advantage of this Limited Warranty, please follow these steps:

1. Please retain your sales slip or invoice, as Vendor may require reasonable proof of your date of purchase.
2. Contact Vendor’s Customer Service Department using the contact information listed below.
3. Return parts to Vendor, per Vendor’s instructions, at your cost and expense.
4. Upon receipt by Vendor, Vendor shall advise you in writing whether a defect covered by this Limited Warranty exists in any returned part and whether your claim has been approved or denied.
5. Upon Vendor’s approval of your claim, Vendor will replace such defective part without charge to you.

WHAT THIS LIMITED WARRANTY DOES NOT COVER: This Limited Warranty does not cover any failures or operating difficulties of the Product due to accident, abuse, misuse, alteration, misapplication, improper installation or improper maintenance or service by you or any third party, or failure to perform normal and routine maintenance on the Product, as set out in the User’s Manual. In addition, this Limited Warranty does not cover damages to the finish, such as scratches, dents, discoloration or rust after purchase.

This Limited Warranty is the only express warranty given on the Product and is in lieu of all other express warranties. Vendor disclaims all warranties for products that are purchased from seller other than authorized retailers or distributors. THIS LIMITED WARRANTY RESTRICTS THE DURATION OF ANY AND ALL IMPLIED WARRANTIES, INCLUDING WITHOUT LIMITATION, THE IMPLIED WARRANTY OF MERCHANTABILITY AND FITNESS FOR A PARTICULAR PURPOSE TO THE ONE (1) YEAR TERM OF THIS LIMITED WARRANTY. UPON THE EXPIRATION OF THE ONE (1) YEAR TERM OF THIS LIMITED WARRANTY, VENDOR DISCLAIMS ANY AND ALL IMPLIED WARRANTIES, INCLUDING WITHOUT LIMITATION THE IMPLIED WARRANTIES OF MERCHANTABILITY AND FITNESS FOR A PARTICULAR PURPOSE, THE PRODUCT BEING THUS SOLD AS-IS, WITH ALL FAULTS. FURTHER, VENDOR SHALL HAVE NO LIABILITY WHATSOEVER TO PURCHASER OR ANY THIRD PARTY FOR ANY SPECIAL, INDIRECT, PUNITIVE, INCIDENTAL, OR CONSEQUENTIAL DAMAGES. OTHER THAN THIS LIMITED WARRANTY, THERE ARE NO WARRANTIES WHICH EXTEND BEYOND THE DESCRIPTION ON THE FACE HEREOF. Vendor assumes no responsibility for any defects caused by third parties. This Limited Warranty gives you specific legal rights, and you may have other rights which vary from state to state. State law may also override statements in this Limited Warranty regarding the restriction on the duration of implied warranties. Some jurisdictions do not allow exclusion or limitation of special, incidental or consequential damages, or limitations on how long a warranty lasts, so the above exclusion and limitations may not apply to you.

Brio[®]

Contact Us

Call: +1 844-257-4103