

moderna + CAFÉ™



Brio®

Bottom Load Water Dispenser
& Coffee Maker

User's Manual

Model: CLBL730SCCF

Table of Contents

Safety Information	3
Intended Use	4
Product Features	4
Touch Panel Description	5
Operational Specifications	5
Technical Specifications	5
Installation	6
Determine Installation Location	6
Install Brewer Drawer and Drip Trays	6
Connect a Water Bottle	6
Operation	7
Turn the Dispenser On/Off	7
Set the Time	7
Dispense Cold Water	7
Disable Child Safety Lock and Dispense Hot Water	8
Preparing Beverages	8
Change the Water Bottle	8
Troubleshooting	9
Cleaning and Maintenance	9
Care and Maintenance	9
Clean the Reservoirs	10
Warranty	11

Safety Information

WARNING: To reduce risk of injury and property damage, you must read this entire guide before assembling, installing and operating the dispenser.

WARNING: This product dispenses water at very high temperatures. Failure to use properly can cause personal injury. When operating this dispenser, always exercise basic safety precautions, including the following:

- Prior to use, this dispenser must be properly assembled and installed in accordance with this manual.
- For indoor use only. Keep the water dispenser in a dry place away from direct sunlight. Do NOT use outdoors.
- Install and use only on a hard, flat and level surface.
- Do NOT place the water dispenser in an enclosed space or cabinet.
- Do NOT operate the dispenser in the presence of explosive fumes.
- Use only properly grounded outlets.
- Do not use an extension cord.
- Always grasp the plug and pull straight out from the outlet. Never unplug by pulling on the power cord.
- Do NOT use the dispenser if the cord becomes frayed or otherwise damaged. If the supply cord is damaged, it must be replaced by the manufacturer, its service agent or similarly qualified persons in order to avoid a hazard.
- To protect against electric shock, do NOT immerse cord, plug, or any other part of the dispenser in water or other liquids.
- Do not use this dispenser with water that is microbiologically unsafe or of unknown quality.
- Water dispenser is compatible with 3- or 5-gallon (12- or 19- liter) water bottles.
- Clean up all water spills after loading or unloading water bottles from the dispenser.
- Ensure the water dispenser is unplugged prior to cleaning.
- Never allow children to dispense hot water without proper and direct supervision. Unplug the unit to prevent unsupervised use by children.
- Service should be performed only by a certified technician.
- The appliance must not be cleaned by a water jet and is not suitable for installation in an area where a water jet could be used.

WARNING: Keep ventilation openings, in the dispenser enclosure or in the built-in structure, clear of obstruction.

WARNING: Do not use mechanical devices or other means to accelerate the defrosting process, other than those recommended by the manufacturer.

- This dispenser should work under environment of temperatures from 39–100 °F (4–38 °C) and humidity \leq 90%.
- Never turn the dispenser upside down or lean it more than 45°.
- After turning the dispenser off, allow the dispenser to sit idle for 3 minutes before turning on again.

WARNING: UV light source. Disconnect the electrical supply to the UV radiation BEFORE opening cover.

- UV-LED lamp must be repaired by manufacturer only.
- UV-LED lamp model no. YB09-950-022, rated DC 24V, 0.17W \pm 20%.
- Disposal of the UV-LED lamp must be done in accordance with local laws and regulations.

Intended Use

This dispenser is intended to be used in household and similar applications such as:

- Staff kitchen areas, offices, and other working environments
- Farm houses
- Hotels, motels and other residential-type environments
- Bed-and-breakfast type environments
- Catering and similar non-retail applications

This dispenser is not intended for use by persons (including children) with reduced physical, sensory or mental capabilities, or lack of experience and knowledge, unless they have been given supervision or instruction concerning use of the appliance by a person responsible for their safety.

Product Features

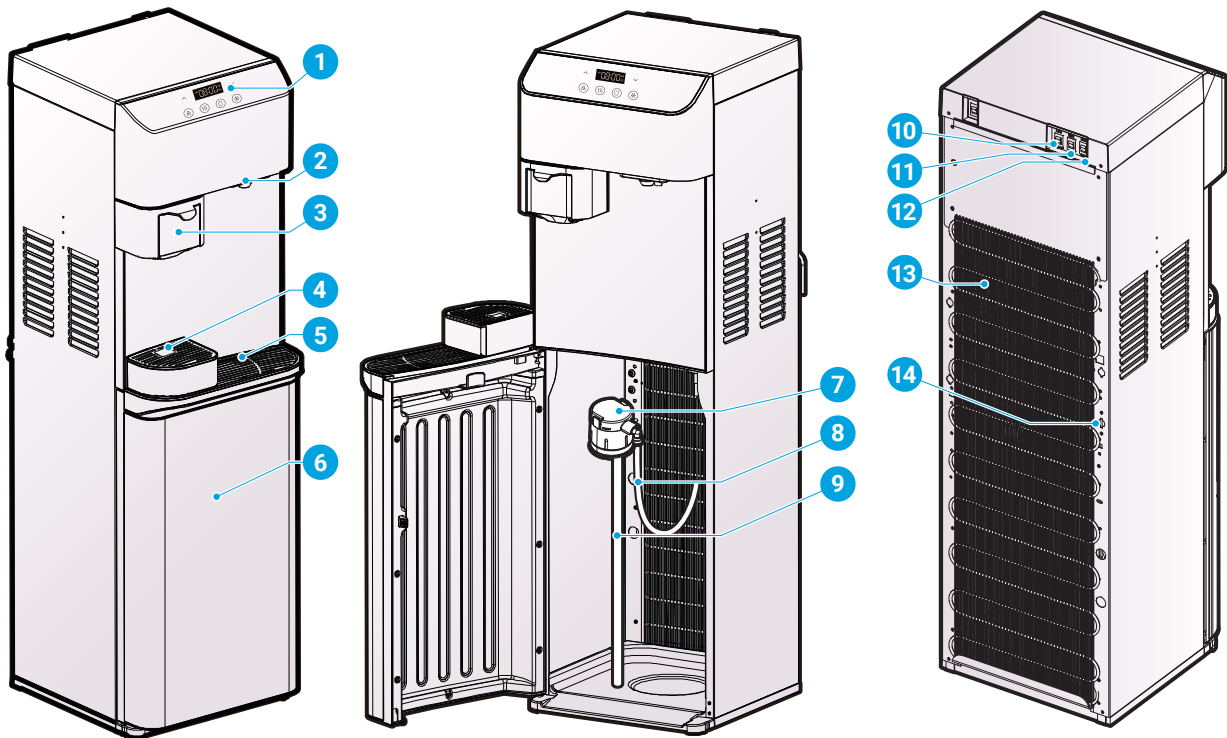

Part	Description
1	Touch panel display
2	Water tap
3	Brewer cup drawer
4	Coffee drip tray
5	Water drip tray
6	Water bottle cabinet
7	Bottle adapter

Part	Description
8	Water line
9	Bottle adapter tube
10	Night light switch
11	Cold water switch
12	Hot water switch
13	Condenser
14	Drain outlet

Touch Panel Description

No.	Description
1	Up arrow button
2	LED display
3	Change bottle icon
4	Self-cleaning UV icon
5	Down arrow button
6	Lock button
7	Hot water button
8	Brew button
9	Cold water button

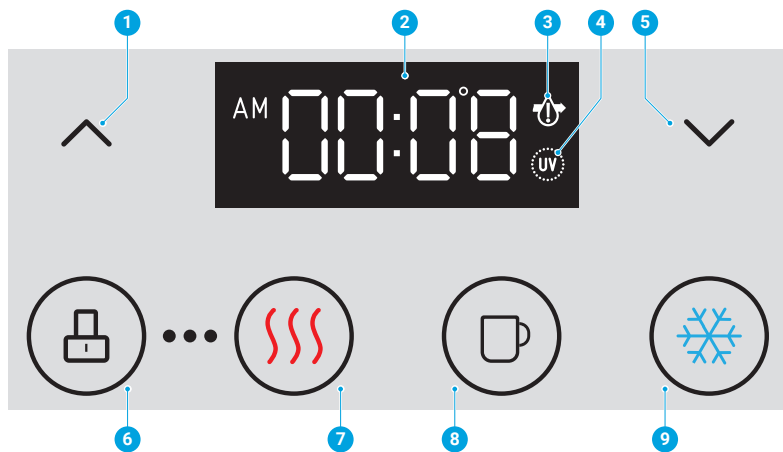

Operational Specifications

You must use the dispenser within the following operational parameters to ensure safe, optimal performance.

Model No.	CLBL730SCCF
Rated Voltage / Frequency	115 V / 60 Hz
Heating Power	700 W
Cooling Power	100 W
Operating Ambient Temperature	39–100 °F (4–38 °C)
Operating Humidity	≤90%

Technical Specifications

CAUTION: This unit dispenses water at temperatures that can cause severe burns. Avoid direct contact with hot water. Keep children and pets away from unit while dispensing. Never allow children to dispense hot water without proper and direct supervision. Unplug unit to prevent unsupervised use by children.

Model No.	CLBL730SCCF
Hot Water Tank Volume	1 L
Cold Water Tank Volume	3.6 L
Hot Water Capacity (Measured at Ambient Temperature of 77 °F / 25 °C)	6 L/h (≥185° F / 85° C)
Cold Water Capacity (Measured at Ambient Temperature of 77 °F / 25 °C)	2 L/h (≤50° F / 10° C)
Hot Water Flow Rate	≥1.5 L/min
Cold Water Flow Rate	≥2.7 L/min
Net Weight	37.91 lb (17.2 kg)
Product Dimensions (WxHxD)	12.2 x 40.94 x 13.39 in. (31 x 104 x 34 cm)
Water Dispense Point to Water Drip Tray (H)	11.5 in. (29.21 cm)
Coffee Dispense Point to Coffee Drip Tray (H)	6.22 in. (15. 8 cm)
Coffee Dispense Point to Water Drip Tray (H)	8.26 in. (20.98 cm)
Water Drip Tray Dimensions (WxD)	11.5 x 4 in. (29.21 x 10.16 cm)
Noise (dBA)	≤55 dB

Installation

1. Determine Installation Location

- A. Place the dispenser upright.
- B. Locate the dispenser on a hard and level surface in a cool shaded location near a grounded wall outlet.
NOTICE: Do NOT plug in the power cord until the entire installation section is completed.
- C. Position the back of the dispenser no closer than 20 cm (8 in.) from a wall and permit free airflow between the wall and water dispenser.

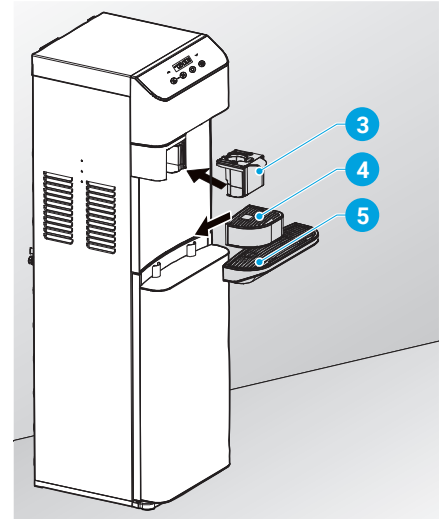

2. Install the Brewer Drawer and Drip Trays

- A. Unwrap brewer cup drawer (3) and drip trays (4 and 5) from the packaging material and slide them onto the dispenser as shown in the illustration, until securely in place.

3. Connect a Water Bottle

IMPORTANT: To prevent dry heating, do not turn on the heating and cooling switches until you complete the steps in this procedure.

- A. Remove the plastic wrapping and cap from the water bottle and clean the new bottle with a clean cloth.
- B. Open the cabinet door and feed the bottle adapter tube (9) into the water bottle. Ensure the tube hits the bottom of the bottle.
- C. For a 5-gallon bottle, place the bottle adapter (7) over the neck of the water bottle and press securely into place.
- D. For a 3-gallon bottle, press down on the two tabs on top of the bottle adapter (7) and slide the cap down the probe tubing to adjust the bottle adapter to fit.
- E. Slide the water bottle into the dispenser cabinet and close the door.
- F. Wait 5 minutes for the water tanks to fill with water before attempting to use the dispenser.
- G. Remove air from the tanks by placing a cup under each water tap and drain at least 4 cups (1 liter) of water before initial use.

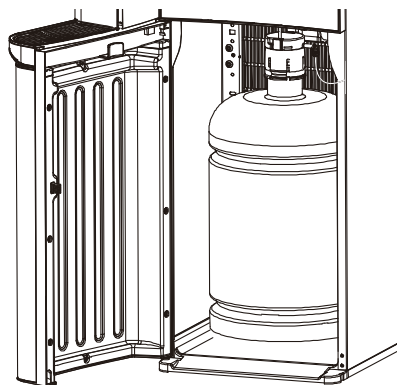
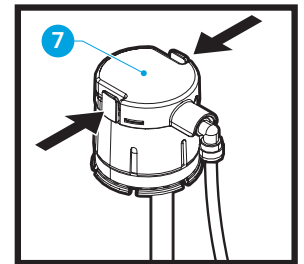
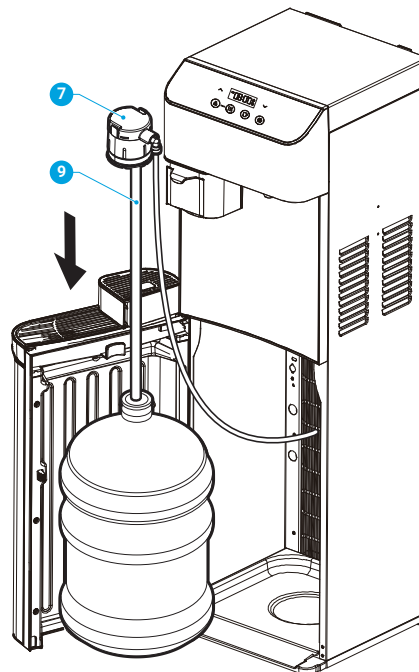

NOTE: Water will not pump from the bottle until the door is completely closed.

Operation

IMPORTANT: This unit has been tested and sanitized prior to packing and shipping. During transit, dust and odors can accumulate in the tank and lines. Dispense and dispose at least one quart of water prior to drinking any water.

Turn the Dispenser On/Off

IMPORTANT: Before you turn the dispenser on and activate the hot and cold switches, ensure a bottle is installed.

1. Plug in the dispenser.
2. Run water through the tap until water begins to dispense.
3. To power on the cooling system, flip the cooling switch on the back of the dispenser to the On position. The cold water button on the front of the dispenser illuminates in blue indicating that the dispenser is cooling water. The light changes to white when the cooling process is complete.
4. To power on the heating system, flip the heating switch on the back of the dispenser to the On position. The hot water button on the front of the dispenser illuminates in red indicating that the dispenser is heating water. The light changes to white when the heating process is complete.

Set the Time

1. Press and hold the up and down arrow buttons for 3 seconds until the clock display begins to flash.
2. Press the cold water button to set the minute and the hot water button to set the hour. Use the up and down arrow buttons to scroll until the correct minute/hour is displayed.
3. Press the hot water lock button when finished.

Set the Cold Water Temperature Level

You can select from 3 different cold water dispensing temperature levels: C1 (cold), C2 (colder), and C3 (coldest).

Temperature Level	Dispensing Temperature Range
C1	49°F to 55°F
C2	43°F to 49°F
C3	37°F to 43°F

NOTE: The default temperature dispensing level for cold water is C3 (coldest).

To change the cold water temperature dispensing level, please do the following:

1. Simultaneously press and hold the down arrow and cold water button for 3 seconds. The cold water button and LED display showing the current cold water temperature level begin to flash.
2. Press the up or down arrow to scroll through the 3 options. They will be displayed as C1, C2, and C3. After you have reached the desired temperature level, quickly press the lock button. The new level is now set. It takes approximately 2 hours for the cold water temperature range to adjust to the new level. During the adjustment process, the cold water light will illuminate in blue. Once the new level has been reached, the light will change to white.

NOTE: Cold water temperature is measured inside cold reservoir tank. Due to many variables, including but not limited to, ambient temperature, water receptacle size/temperature, internal travel from reservoir tank to dispense point, etc., temperature range of water dispensed will vary from stated range.

Dispense Cold Water

NOTE: Water will take approximately 1 hour after plugging in and turning on to become completely chilled.

1. Place a drinking glass or container under the tap and press the cold water button to dispense cold water or the ambient water button to dispense room temperature water.
2. Release the button when your container is full.

Disable Child Safety Lock and Dispense Hot Water

CAUTION: This unit dispenses water at temperatures that can cause severe burns. Avoid direct contact with hot water. Keep children and pets away from the unit while dispensing. Never allow children to dispense hot water without proper and direct supervision. Disable the heating feature by switching the heating convenience switch to the Off position.

NOTE: Water will take approximately 15-20 minutes after plugging in and turning on to reach its hottest temperature.

1. This water dispenser is equipped with a child safety feature in order to prevent inadvertent dispensing. To disable the child safety lock feature, lightly tap the lock button.
2. To dispense hot water, place a drinking glass or container under the tap and press the hot water button.
3. Release the button when your container is full. Hot water button automatically relocks.

Preparing Beverages

1. Pull out the brewer cup drawer and remove it completely from the dispenser.
2. Insert coffee capsule of your choice (sold separately) and press it firmly into place until the needle has fully punctured the bottom of the capsule, and the top of the capsule is level with the top of the drawer.
3. Slide the drawer into the dispenser and press until firmly in place. The 8-ounce serving size light will flash on the display screen.
4. Press the Up arrow button or Down arrow button for your desired serving size of 6, 8, or 10 ounces. Once your size selection has been made, press the Brew button. The screen will display the selected beverage size and the coffee button light will flash, then brewing will begin. There may be a short delay if hot water has not reached the appropriate temperature. Brewing will commence as soon as temperature is reached.
5. If you don't make a serving size selection within 5 seconds, the serving size light will turn off to prevent inadvertent dispensing of hot water. To reactivate serving size selection, simply remove and reinsert brewer cup drawer, then make your selection.
6. When brewing is complete, pull out the drawer and discard the used coffee capsule, then reinsert drawer in dispenser.
7. Approximately three 6- or 8-ounce servings, or two 10-ounce servings can be brewed consecutively. The hot water button light will illuminate in red as water is heating for the next serving. Please note that it may take a few minutes for the next brewing cycle to commence.

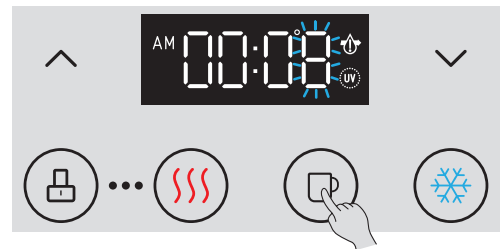

Change the Water Bottle

CAUTION: Do not dispense hot or cold water if the change bottle icon is flashing on the display as you could empty the tanks and cause the dispenser to overheat.

When the change bottle icon on the top-right corner of the display begins to flash, it is time to replace your empty water bottle with a new water bottle:

1. Open the dispenser cabinet door and slide the empty bottle out of the cabinet.
2. Remove the bottle adapter from the empty bottle and let the probe drip into the bottle. Once dripping has stopped, place the bottle adapter on the hanger and set the empty bottle aside.
3. Follow the steps in **Connect a Water Bottle** to install your new water bottle.
4. Recycle the empty bottle at your local exchange center to receive your next bottle at a discount.

Troubleshooting

Problem	Solution
The cold water is not cold.	<ul style="list-style-type: none"> • It takes up to one hour after setup to dispense cold water. • Make sure the power cord is properly connected to a working outlet. • Make sure the back of the dispenser is at least 20 cm from a wall and there is free airflow on all 20 cm sides of the dispenser. • Make sure green power switch on back of dispenser is On. • If water still isn't cold, call customer service at +1 844-257-4103 for assistance.
The hot water is not hot.	<ul style="list-style-type: none"> • It takes 15-20 minutes after setup to dispense hot water. • Make sure the power cord is properly connected to a working outlet. • Make sure red power switch on back of dispenser is On.
The night light is not working.	<ul style="list-style-type: none"> • Make sure the power cord is properly connected to a working outlet • Make sure the night light power switch on back of dispenser is On.
The dispenser is noisy.	<ul style="list-style-type: none"> • Ensure the dispenser is located on a level surface. • The heating tube may be generating a slight noise. This is normal.
The bottle is leaking.	<ul style="list-style-type: none"> • Ensure the bottle is installed correctly. • Check to see if the bottle is cracked or broken. If so, replace the bottle.
The dispenser is not dispensing water.	<ul style="list-style-type: none"> • Check to see if the bottle is empty and replace with a new bottle if necessary. • There may still be air in the tank. Press and hold the water taps to remove air until water begins to flow.
The dispenser is not dispensing coffee or is dispensing coffee slowly.	<ul style="list-style-type: none"> • Brew coffee without using coffee capsules several times, or until water dispenses normally from coffee brewer.

Cleaning and Maintenance

This dispenser runs on a continuous UV cleaning cycle. It works for 40 minutes (UV icon on display is illuminated), turns off for 140 minutes, and then cycles back on again as long as the dispenser is plugged in and on.

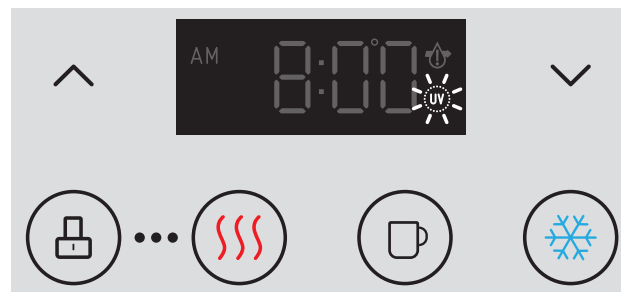

Care and Maintenance

- Brewer cup drawer and drip trays are dishwasher safe; however, washing in high temperatures or using a “sanitize” cycle is not advised.
- Keep this dispenser in a dry and cool place and avoid direct sunshine.
- Ensure the back of the dispenser is at least 20 cm (8 in.) away from the wall.
- Never put the dispenser on paper or foam, which may store water and then cause creepage. Never put anything flammable beside this machine.
- Do not use the dispenser outdoors or in a place that can be splashed by water.
- If the dispenser is not in use for longer than a 24-hour period, turn off the heating switch or the refrigerating switch to save power and drain any remaining water.
- Clean your cabinet, controls, bottle probe and spout each time you change your water bottle. Use a clean soft cloth and a food grade sanitizer or bleach.
- Empty and clean the drip tray, grid and float as needed.

Clean the Reservoirs

The reservoirs should be cleaned every 3 to 4 months to remove mineral buildup and optimize dispenser performance.

Gather the following supplies:

- 200g (approx. 1.5 cups) citric acid crystals
 - Hot water
 - Large bucket or empty 5-gallon bottle
 - Container or cup
 - Clean dry cloth
- A. Turn the hot and cold water switches to the OFF position, and unplug the dispenser.
 - B. Remove the water bottle, then move the dispenser away from the wall to gain access to the back.
 - C. Plug the dispenser back in and drain remaining water from the reservoirs by dispensing from all the taps into a container.
 - D. Pour citric acid crystals, then 2 gallons of hot water into the 5-gallon bottle or bucket. Stir or agitate briefly to mix.
 - E. Insert the bottle adapter tube into the bottle or bucket with the solution, secure the cap if using a bottle, and slide into dispenser, shutting door securely.

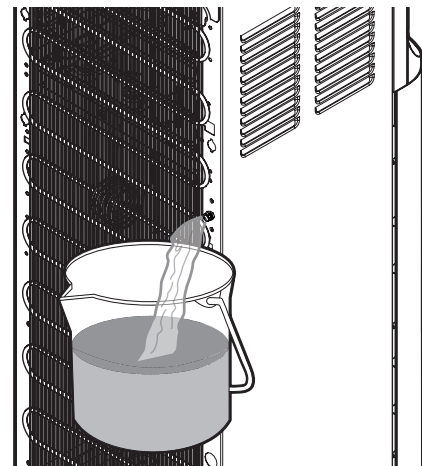
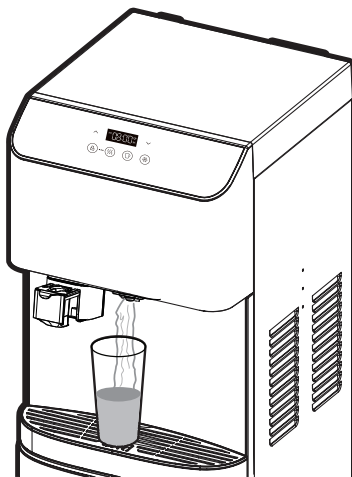
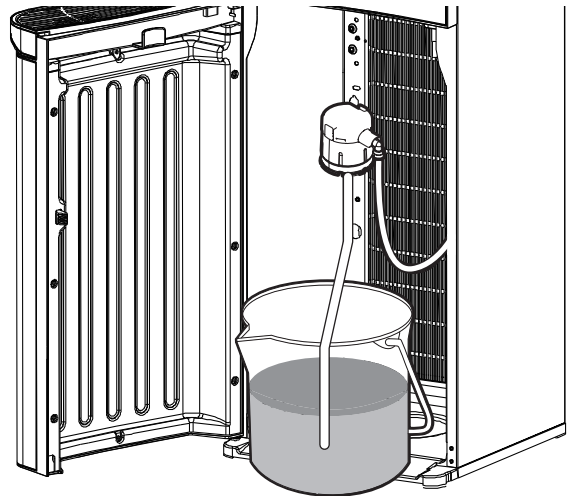

- F. Allow the cleaning solution to fill the reservoirs. Then dispense a small amount of the solution from tap into the cup or container.
- G. Wait 20 minutes, then drain the reservoirs as described in step C. Rinse out the solution bottle or bucket, then fill with 2 gallons of fresh hot tap water and repeat process described in step E. Allow reservoirs to fill.
- H. Place a 3-gallon bucket at the back of the dispenser. Remove the drain plug while simultaneously pressing the dispense buttons. Once reservoirs have been drained, replace drain plug.
- I. Return dispenser to its location, install a fresh bottle of water, and turn hot and cold switches ON.
- J. If any odor or taste persists after cleaning, repeat the above steps using 2 cups of white vinegar and 2 gallons of water.

Warranty

Brio (“Vendor”) warrants to the original purchaser of the Brio Water Cooler (the “Product”), and to no other person, that if the Product is assembled and operated in accordance with the printed instructions accompanying it, then for a period of one (1) year from the date of purchase, all parts in the Product shall be free from defects in material and workmanship. This Limited Warranty shall be limited to repair or replacement of parts, which prove defective under normal use and service and which Vendor shall determine in its reasonable discretion upon examination to be defective. To take advantage of this Limited Warranty, please follow these steps:

1. Please retain your sales slip or invoice, as Vendor may require reasonable proof of your date of purchase.
2. Contact Vendor’s Customer Service Department using the contact information listed below.
3. Return parts to Vendor, per Vendor’s instructions, at your cost and expense.
4. Upon receipt by Vendor, Vendor shall advise you in writing whether a defect covered by this Limited Warranty exists in any returned part and whether your claim has been approved or denied.
5. Upon Vendor’s approval of your claim, Vendor will replace such defective part without charge to you.

WHAT THIS LIMITED WARRANTY DOES NOT COVER: This Limited Warranty does not cover any failures or operating difficulties of the Product due to accident, abuse, misuse, alteration, misapplication, improper installation or improper maintenance or service by you or any third party, or failure to perform normal and routine maintenance on the Product, as set out in the User’s Manual. In addition, this Limited Warranty does not cover damages to the finish, such as scratches, dents, discoloration or rust after purchase.

This Limited Warranty is the only express warranty given on the Product and is in lieu of all other express warranties. Vendor disclaims all warranties for products that are purchased from seller other than authorized retailers or distributors. THIS LIMITED WARRANTY RESTRICTS THE DURATION OF ANY AND ALL IMPLIED WARRANTIES, INCLUDING WITHOUT LIMITATION, THE IMPLIED WARRANTY OF MERCHANTABILITY AND FITNESS FOR A PARTICULAR PURPOSE TO THE ONE (1) YEAR TERM OF THIS LIMITED WARRANTY. UPON THE EXPIRATION OF THE ONE (1) YEAR TERM OF THIS LIMITED WARRANTY, VENDOR DISCLAIMS ANY AND ALL IMPLIED WARRANTIES, INCLUDING WITHOUT LIMITATION THE IMPLIED WARRANTIES OF MERCHANTABILITY AND FITNESS FOR A PARTICULAR PURPOSE, THE PRODUCT BEING THUS SOLD AS-IS, WITH ALL FAULTS. FURTHER, VENDOR SHALL HAVE NO LIABILITY WHATSOEVER TO PURCHASER OR ANY THIRD PARTY FOR ANY SPECIAL, INDIRECT, PUNITIVE, INCIDENTAL, OR CONSEQUENTIAL DAMAGES. OTHER THAN THIS LIMITED WARRANTY, THERE ARE NO WARRANTIES WHICH EXTEND BEYOND THE DESCRIPTION ON THE FACE HEREOF. Vendor assumes no responsibility for any defects caused by third parties. This Limited Warranty gives you specific legal rights, and you may have other rights which vary from state to state. State law may also override statements in this Limited Warranty regarding the restriction on the duration of implied warranties. Some jurisdictions do not allow exclusion or limitation of special, incidental or consequential damages, or limitations on how long a warranty lasts, so the above exclusion and limitations may not apply to you.



Contact Us

Call: +1 844-257-4103