

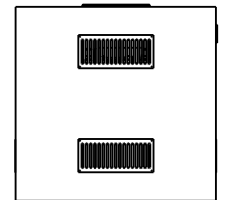

**Hearth Products Controls Co**  
FOR COMMERCIAL AND RESIDENTIAL USE

HEARTH PRODUCTS CONTROLS  
2225 LYONS RD.  
MIAMISBURG, OH 45342  
TOLL FREE: 877.585.9800  
PHONE: 937.436.9800  
www.hpcfire.com

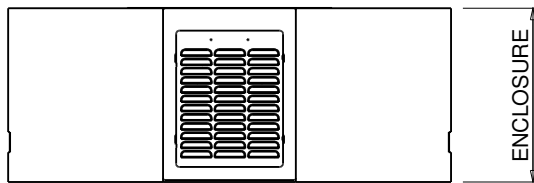
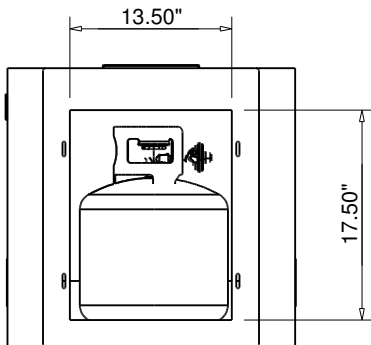
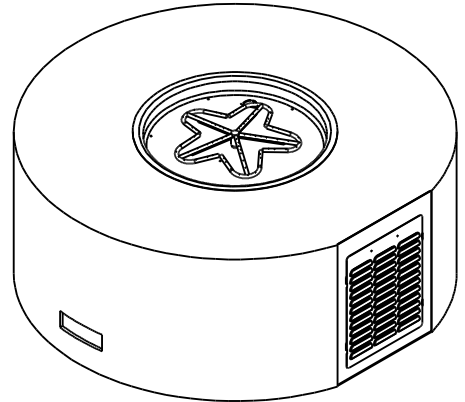
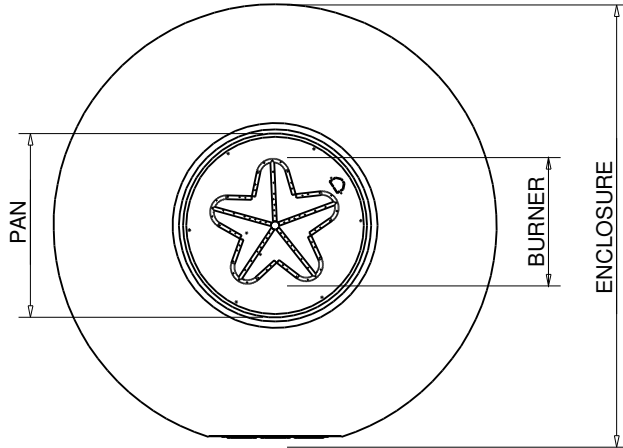

MODEL	BTU	DIMENSION CHART		
		ENCLOSURE	PAN	BURNER
UST60R/FPPK25CEK-LP	90k	60X23.5"	25"	18"
UST60R/MLFPK25CEK-LP	65k	60X23.5"	25"	18"

**Notes:**

1. PROPER VENTING
  - ENCLOSURES: Recommend 4 each 18 sq.in. vents
2. GAS SUPPLY - FOR USE WITH SMALL TANKS.
  - LP Gas: Operating Supply Pressure: Minimum: 10.0" W.C.; Maximum: 11.0" W.C.
3. MODIFICATION OF PRODUCT WILL VOID ANY CERTIFICATION AND WARRANTY.
4. FOLLOW ALL MANUFACTURER INSTALLATION INSTRUCTIONS AND LOCAL CODES.
5. ALL DIMENSIONS ARE CONSIDERED TRUE AND REFLECT MANUFACTURER'S SPECIFICATIONS AS OF THE REVISION DATE.
6. DO NOT SCALE DRAWING.
7. THESE DRAWINGS ARE FOR SIZING AND PLANNING PURPOSES. ALL INFORMATION CONTAINED HEREIN WAS CURRENT AT THE TIME OF DEVELOPMENT. THE MANUFACTURER'S RESPONSIBLE FOR THE ACCURACY OF THE DRAWING.
8. CONTRACTOR'S NOTE: FOR PRODUCT AND COMPANY INFORMATION VISIT [www.CADdetails.com/info](http://www.CADdetails.com/info) REFERENCE NUMBER 771-072.

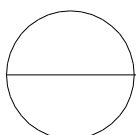

READY TO FINISH ROUND SMALL TANK SERIES