

NAPOLEON

BOASTS BEAUTY AND
PERFORMANCE

INTRODUCING

A FULL LINEUP OF ASCENT™ LINEAR



napoleon.com

Ascent™ Linear Series

The Napoleon Ascent™ Linear Series is the perfect solution for any homeowner, remodeler or builder looking for a contemporary Direct Vent Gas Fireplace without the premium price. Now available in 4 sizes - 36, 42, 46 and 56 the Ascent Linear will enhance any space with it's clean face design. The ability to frame the same as it's sister series, the Ascent, means that it is an easy transition between traditional to contemporary should the homeowner choose. The addition of the MIRRO-FLAME™ Porcelain Reflective Panels create even more impact with the flame and a sleek, elegant statement. The Ascent™ Linear comes with the exclusive Topaz CRYSTALINE™ ember bed that can easily be enhanced or changed out for a completely new look with the mix and match media enhancement kits - ensuring the perfect amount of customization.

Product Features

- BTU's BL36 - 17,500, BL42 - 22,000, BL46 - 24,000, BL56 - 28,000
- Optional Remote Control
- Simplified installation (steel header no longer required)
- Clean face design with high quality safety barrier
- Optimized burner performance (for all vent and fuel configurations)
- CRYSTALINE™ ember bed comes with Topaz crushed glass included
- Low profile optional front available in black
- Optional premium blower kit
- Optional media includes: MIRRO-FLAME™ Porcelain Reflective Radiant Panels, Mineral Rock Kit, Shore and Beach Fire Media Kits, Glass Ember Media and Glass Beads in various colors!



Features / Options / Accessories



Classic four-sided surround in black shown with Black Glass Beads



Beach Fire kit



Shore Fire kit

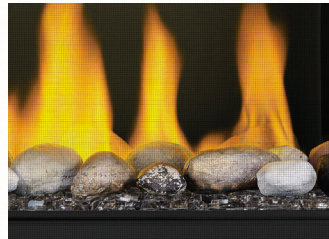

Mineral Rock kit on Black Glass Beads



Beach Fire Kit and Shore Fire Kit on Clear Glass Embers



CRYSTALINE™ ember bed shown with blue glass embers



Blower



MIRRO-FLAME™ Porcelain Reflective Radiant Panels



Optional Remote Control

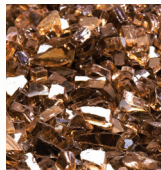
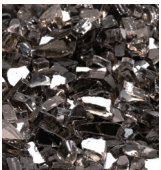

Glass Ember Media Kits

Black, Blue, Red, Amber, Clear and Topaz

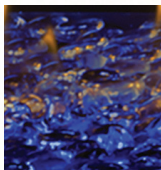

Glass Beads Media Kits

Black, Blue, Amber, Clear and Topaz

Specifications

Model	BTU'S (Input)	Top Venting	Height		Front Width		Depth		Glass Size	
			Actual	Framing	Actual	Framing	Actual	Framing	Height	Width
BL36-1	17,500	4" x 7" Top	39 1/16"	39 3/8"	35 15/16"	36 1/2"	15 3/4"	16"	16 3/4"	30 1/2"
BL42	22,000	4" x 7" Top	39 1/16"	39 3/8"	42"	42 1/2"	18 5/16"	18 9/6"	16 3/4"	37 1/2"
BL46	24,000	4" x 7" Top	39 1/16"	39 3/8"	46 7/8"	47 3/8"	18 5/16"	18 9/6"	16 3/4"	41 1/2"
BL56	28,000	5" x 8" Top	39 1/16"	39 3/8"	56"	56 1/2"	18 5/16"	18 9/6"	16 3/4"	51 1/2"

Certified under Canadian and American National Standards

Figures may vary with individual conditions such as floor plan layout, insulation value/heat loss of the house and geographical location.

BL36-1

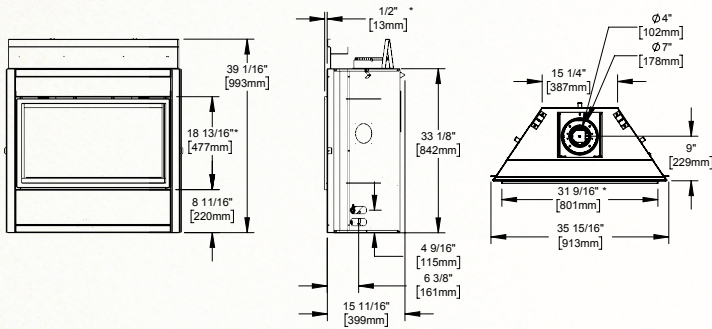

BL42

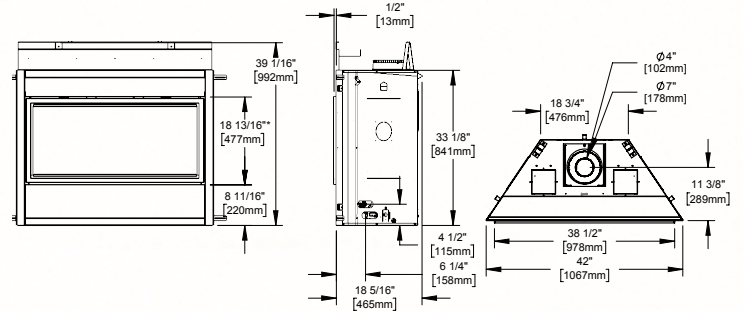

BL46

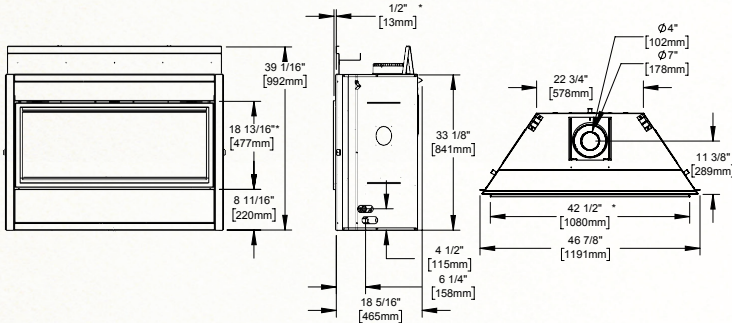

BL56

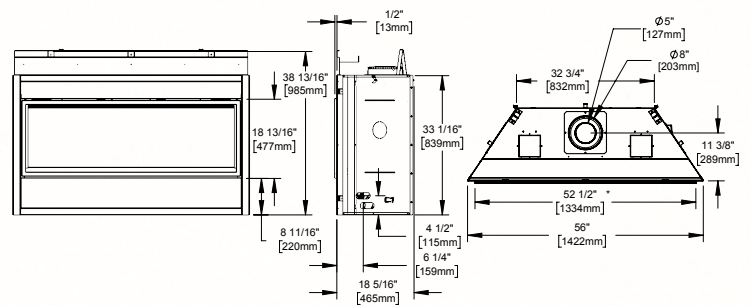

*Finishing flange depth (The finishing flange defines the perimeter of the fireplace opening. Framing or finishing materials must NEVER encroach inside the finishing flange)

Authorized Dealer



24 Napoleon Road, Barrie, Ontario, Canada L4M 0G8
 103 Miller Drive, Crittenden, Kentucky, USA 41030
 7200 Trans Canada Highway, Montreal, Quebec, Canada H4T 1A3

Tel: 1-866-820-8686
 napoleon.com



Consult your owner's manual for complete installation instructions, accurate framing dimensions and proper clearances to combustible material. Check all local and national building codes. All specifications are subject to change without prior notice due to on-going product improvements. Products may not be exactly as shown. Napoleon is a registered trademark of Wolf Steel Ltd. © Wolf Steel Inc.

Printed in Canada
 07/2021