

**NAPOLEON**

**EXCEPTIONAL VERSATILITY**

**INTRODUCING THE NEW  
ASCENT™ BX SERIES**



[napoleon.com](http://napoleon.com)

# Ascent BX

Completing the line logic of the Ascent family, comes the new Ascent™ BX. An upgrade from the Ascent B series fireplace, the BX offers premium options of ceramic glass, a remote, blower and lights in the same footprint. Framing width and depth stays the same, making it an easy transition to upgrade a discerning customer looking for more bells and whistles. Available in 36" and 42" widths the Ascent™ BX offers the same versatility of designer options as the rest of the Ascent™ family – from brick panels to trims and fronts. The added benefit of an optional heat management system means the fireplace is truly designed for sensitive items like TV's and artwork. Ensuring that Napoleon's Ascent™ BX really is the heart of any home.

## Competitive Advantages

- Optional heat management for reduced clearance to combustibles
- Will accept Flex and Rigid Venting
- Top and Rear Venting
- Emergency operation with USB power bank (not supplied)
- Wide range of optional accessories
- Premium Safety Barrier



**BX36**

- Up to 26,000 BTU's
- President's Limited Lifetime Warranty
- Heat Radiating Ceramic Glass
- Pan Style Burner
- Flame / Heat Adjustment
- Blower included
- Remote included
- NIGHT LIGHT™ included



**BX42**

- Up to 30,000 BTU's
- President's Limited Lifetime Warranty
- Heat Radiating Ceramic Glass
- Pan Style Burner
- Flame / Heat Adjustment
- Blower included
- Remote included
- NIGHT LIGHT™ included



## Features / Options / Accessories



**MIRRO-FLAME™ Porcelain Reflective Radiant Panels**



**Sandstone Decorative Brick Panels**



**Westminster™ Grey Standard Decorative Brick Panels**

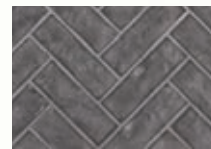

**Westminster Grey Herringbone Decorative Brick Panels**



**Newport™ Decorative Brick Panels**



**Old Town Red™ Herringbone Decorative Brick Panels**

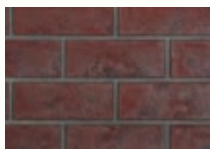

**Old Town Red™ Standard Decorative Brick Panels**



**Zen Front**



**Bevelled Trim 3"**



**Mineral Rock Kit**



**Beach Fire Kit**



**Shore Fire Kit**



**Premium Split Oak Log Set**



**Remote Control (F60)**

# Specifications

Model	BTU's (Input)	Venting	Vent Size	Glass Type	Height		Front Width		Depth		Glass Viewing Area		Remote	Blower
					Actual	Framing	Actual	Framing	Actual	Framing	Height	Width		
BX36	26,000	Rigid & Flex	4/7 Top & Rear	Ceramic	34 5/8"	35"	35"	35 1/2"	15 3/4"	16"	23 11/16"	30 11/16"	Included	Included
BX42	30,000	Rigid & Flex	5/8 Top & Rear	Ceramic	34 5/8"	35"	42"	42 1/2"	18 5/16"	19"	23 11/16"	37 11/16"	Included	Included

Certified under Canadian and American National Standards

Figures may vary with individual conditions such as floor plan layout, insulation value/heat loss of the house and geographical location.

**FRONT VIEW**

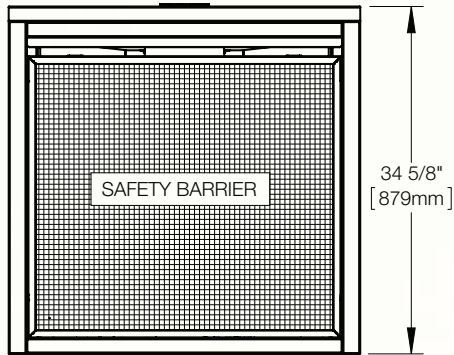

**SIDE VIEW**

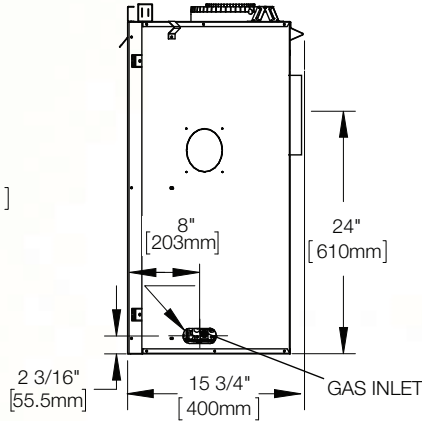

**TOP VIEW**

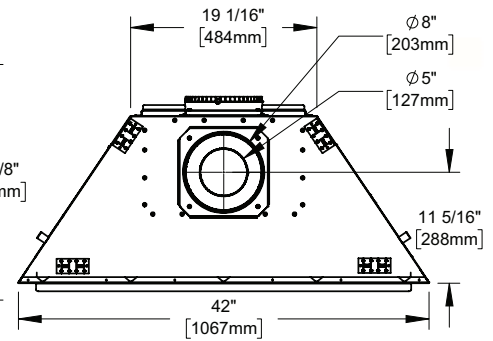
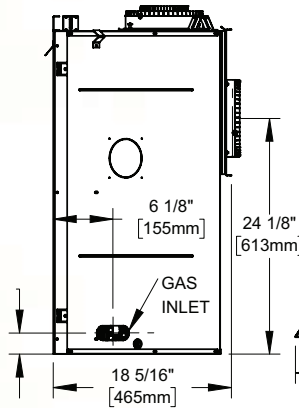
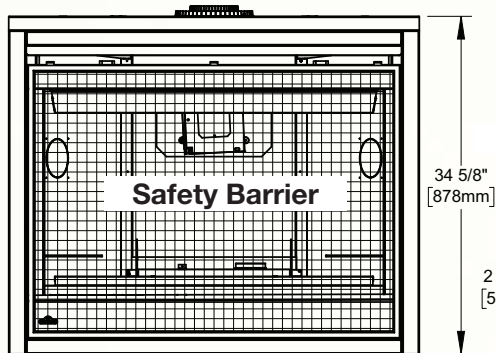
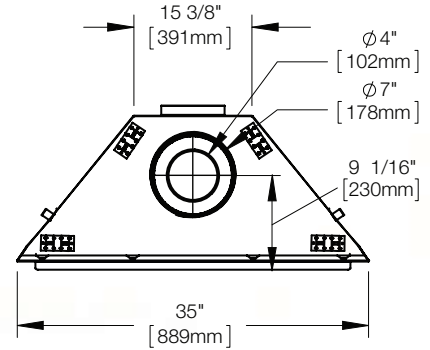

Authorized Dealer

24 Napoleon Road, Barrie, Ontario, Canada L4M 0G8  
 103 Miller Drive, Crittenden, Kentucky, USA 41030  
 7200 Trans Canada Highway, Montreal, Quebec, Canada H4T 1A3

Tel: 1-866-820-8686  
 napoleon.com



Consult your owner's manual for complete installation instructions, accurate framing dimensions and proper clearances to combustible material. Check all local and national building codes. All specifications are subject to change without prior notice due to on-going product improvements. Products may not be exactly as shown. Napoleon is a registered trademark of Wolf Steel Ltd. © Wolf Steel inc.

Printed in Canada  
 01/2022