

THERMADOR

INSTALLATION

INSTRUCTIONS

Before you start, ensure that you thoroughly read and comprehend these instructions. This guide is provided for professional garage door installers.

SAFETY CHECKLIST

Read all safety notices before installing this door.



Safety Notice:

By undertaking the installation of this door, the installer understands the dangers associated with the installation. These dangers can result in serious injury or death and the installer must take all precautions to minimise the risk of such dangers.

The manufacturer is not responsible for any damage to the door or persons derived from improper installation.

HAZARD	CONTROL
Overall	Follow current New Zealand Health and Safety legislation at all times.
Working at Heights	Work from stable ladder. Ensure it is placed correctly on level ground and have a supervisor. Don't work from the top rung. Wear correct safety headgear with chin strap fastened if operating above 2m.
Heavy Lifting	Practise safe lifting techniques when lifting overweight objects. 2-person lift for objects over 25kg. DO NOT manually lift objects heavier than 35kg.

SAFETY CHECKLIST

Sharp Edges	Wear appropriate PPE throughout the installation. Slash-proof gloves are needed especially for handling metal.
Crush Risk	Wear appropriate PPE steel capped boots throughout installation.
Use of Power Tools	Wear appropriate PPE gloves, hearing protection, eye protection throughout installation.
Springs under Tension	Tensioning the torsion springs is dangerous if the correct procedure is not followed. The springs store energy and need careful attention. Read procedure carefully and wear safety glasses and slash proof gloves.
Safety Glasses	Wear safety glasses, especially when drilling or tek screwing.
Opener Power Cord	Disconnect power cord when working on the opener and clear all personnel away from door when trialling operation.

REQUIRED TOOLS AND PARTS

Tools Required

QUANTITY	TYPE	SIZE
1	Battery drill/screwdriver, ideally with adjustable torque settings	6/12/14mm
1	Tek screwdriver adapter with 100mm extension	6/8mm
1	Hand hacksaw	
1	Tape measure	7.5mtr
1	Drill bit set	
1	Level – magnetic if available	
1	Hammer	
1	Wire Cutters	
1	Vice Grips (Locking Pliers)	

REQUIRED TOOLS AND PARTS

1	Long nose pliers	
1	Open ended spanners	10,12,13,14,17mm
1	Adjustable spanner	200mm long
2	12mm adjuster rods x 450mm	
1	Marker pen	
1	Ladder	

REQUIRED TOOLS AND PARTS

Parts Required

QUANTITY	TYPE	SIZE
1	Door panels	In Kit
1	Hardware Kit	In Kit
1	Seal	In Kit
1	Springs	In Kit
1	Track Pack	In Kit
1	Motor Box	In Kit
1	Motor track	In Kit
1	Axle shaft	In Kit
	All fastenings to mount the tracks and the spring system are to be sourced to suit the specific mounting application.	

BEFORE INSTALLATION

Before starting installation of your new garage door please check:

- The door supplied is the correct width, size, colour, and design as ordered.
- All components are supplied (as listed above).
- Is electrical power available at installation site.
- Is the doorway ready to accept the sectional door installation?
 - Check the door jambs have been fitted and measure that the horizontal and vertical measurements are correct for the door opening you are installing, (e.g. 5.2 x 2.1 metre door = inside jamb measurement of 5200mm and floor to top jamb of 2100mm).
 - Check the overhead clearance between the top of door opening and the ceiling is 300mm.
 - Check the garage walls and ceiling have been lined.
 - Check the ceiling access manhole is clear of the left or right-hand track position.
- Check each side of the door opening for fastening points for the mounting brackets. The vertical screws need to be installed at approximately 80mm out from the door opening inside face.
- Clean garage floor and position all components and tools in the garage.

INSTALLATION – DOOR SEALS



Safety Notice:

Wear safety glasses especially when drilling or tek screwing. Tensioning of the torsion springs is dangerous if the correct procedure is not followed. The springs store energy and need careful attention. Read procedure carefully and wear safety glasses and leather gloves.

Work from stable ladder.

Disconnect power cord when working on the opener and clear all personnel away from door when trialling operation.

All Instructions are given from the point of view of someone inside the garage looking out.

Door Seals – Frameless Door Type only

1. Measure up each outside face of the vertical jamb and cut the side seals according to vertical jamb height.
2. Slide the plastic outside cap from the seal, and with the rubber seal facing inward, align the plastic edge of the seal face with the inside edge of the door opening, and screw the seal at 300mm intervals.
3. Cut the top seal to fit between the side seals and fasten in the same manner.

INSTALLATION – TRACK MOUNTING

Door Track Mounting

Marking assembly reference points

Use a level to mark a level reference on the work face approximately 500mm down from the top of the door opening. Then mark a vertical line 65mm in from each side of the door opening.

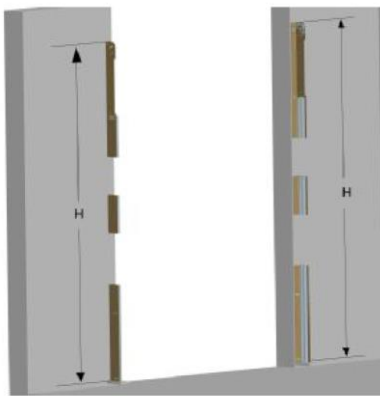

Frameless door type

Vertical tracks

Assemble the left and right flag brackets to the track assemblies as shown above. Fasten the track mounting brackets. Use the dome head screws. Stand the tracks on a 2mm packer and align with the 65mm left and right marks.

Measure up from the level reference line to the top of the flag brackets and adjust heights until equal (as shown in picture above). Secure the flag bracket with appropriate size wood screws or masonry fastener (example 8mmx 50mm complete with washer or 4mm x 50mm screws).

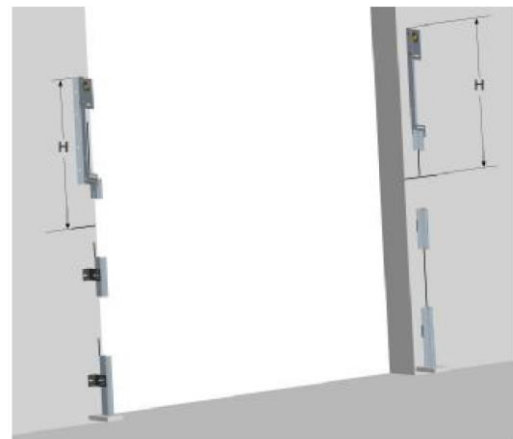

Frame door type

Vertical tracks

Fix gasket on frame. Stand the frame on a 2mm packer and align with the 65mm left and right marks. Measure up from the level reference line to the top of the frame and adjust heights until equal (as shown in picture above). Secure the frame with appropriate size wood screws or masonry fastener (example 8mmx 50mm complete with washer or 4mm x 50mm screws).

INSTALLATION – TRACK MOUNTING

Horizontal Tracks

Frameless Door Type:

Fasten the horizontal tracks (hockey stick shape) to the flag bracket slot, with the dome head screws.

Lift the track into a level position; fit the horizontal angle steel braces from the flag brackets with (bolt and nut) to the side of the track with dome head screws.

Ensure the track is mounted at 90-degree angle to the door opening. Use the angle mounting brackets to support the end of the track through into the ceiling and side brace.

Horizontal Tracks

Frame Door Type:

Fasten the horizontal tracks to the frame/rail curve slot, with the dome head screws.

Ensure the track is mounted at 90-degree angle to the door opening. Use the angle mounting brackets to support the end of the track through into the ceiling and side brace.

INSTALLATION – DOOR TYPES

Overview of various door types

Frameless Door Type

With single rail



Frame Door Type

With single rail



With double steel rail

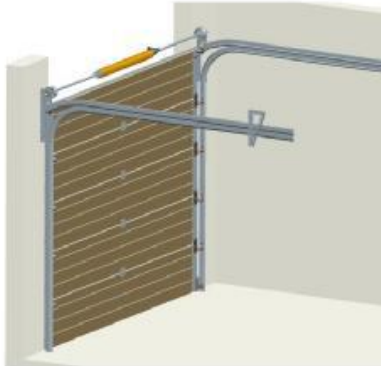

With double steel rail



With PA6 rail curve



With PA6 rail curve

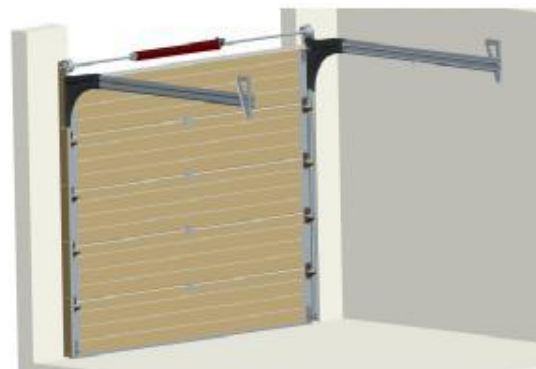

INSTALLATION – DOOR BALANCING

Door Balancing System

1. Right-handed parts are marked RED and cable drums have L' or R' marked on them.
2. Fasten torsion springs to the bearing mounts (bracket cut off facing down), and slide onto the axle shaft, with the adjustment hubs facing outward - 200mm each side of the door centre. Right hand wound spring on Left side / Left-hand spring on Right side (see attached sketch for Identification). Right-hand spring is marked with red and matches the right cable drum which also has a red mark and an R' marked on the outer edge.
3. Fasten cable drums onto the shaft up against the springs temporarily, (adjustment screws facing inward). Right painted red and marked RH.
4. Fasten the R/H bearing mounts above the flag bracket, with suitable heavy duty wall fastenings (8mm x 50mm screws), and bolt to flag bracket. The angled section of the bracket can be cut off if necessary.
5. Lift up axle shaft and insert into R/H main bracket and secure the L/H bearing mount above the left flag bracket, with correct fastenings.
6. Level the shaft and fasten the spring mounts (with the bracket cut off facing down), at 200m each side of the door centre. This allows clearance of the motor track.
7. Loosen the springs and cable drums and adjust the axle shaft to have equal protrusion each side. Lock the spring adjustment set screws.

INSTALLATION – DOOR BALANCING

8. Position the cable drums 3mm from the Left and Right shaft mounts.

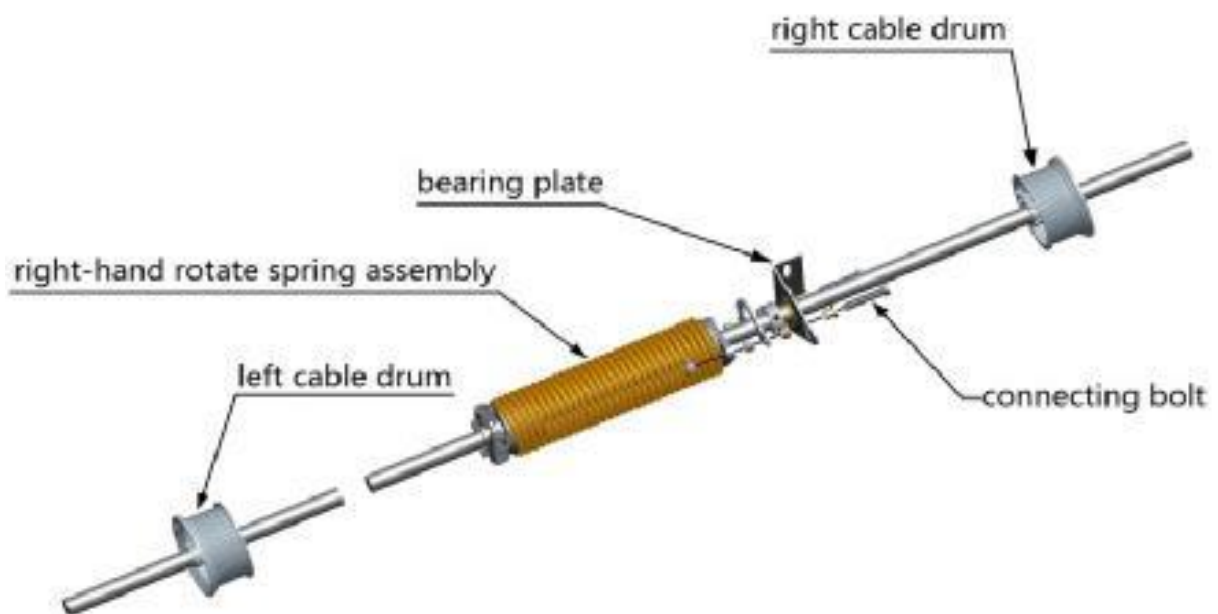
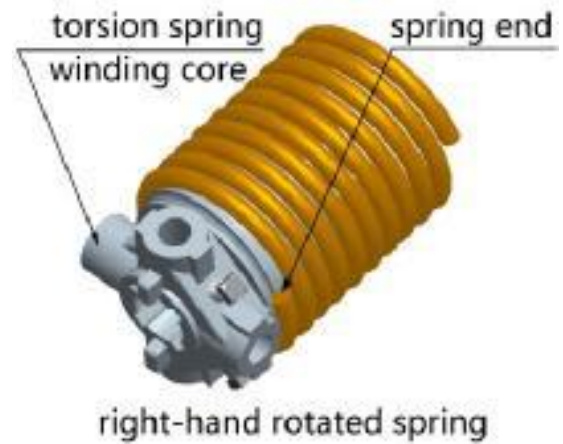
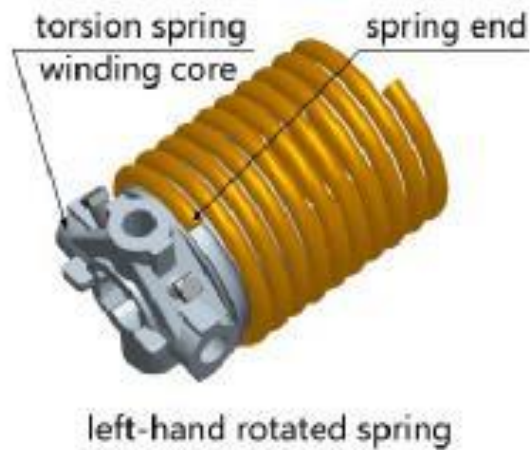

INSTALLATION – TORSION SPRING

Torsion Spring Safety Device



Safety Notice:

The fixation of the spring break device to the wall/support beam must be done with proper fixing materials. This is the responsibility of the installer.

Installation instructions

1. Place the torsion spring (B) with the stationary spring fitting (D) and the spring device with pawl wheel (L) on the door shaft (A).
2. Fix the stationary fitting (D) with help of the bolts (F) with a torque of 10Nm and distance rings (H) on the blocking plate.

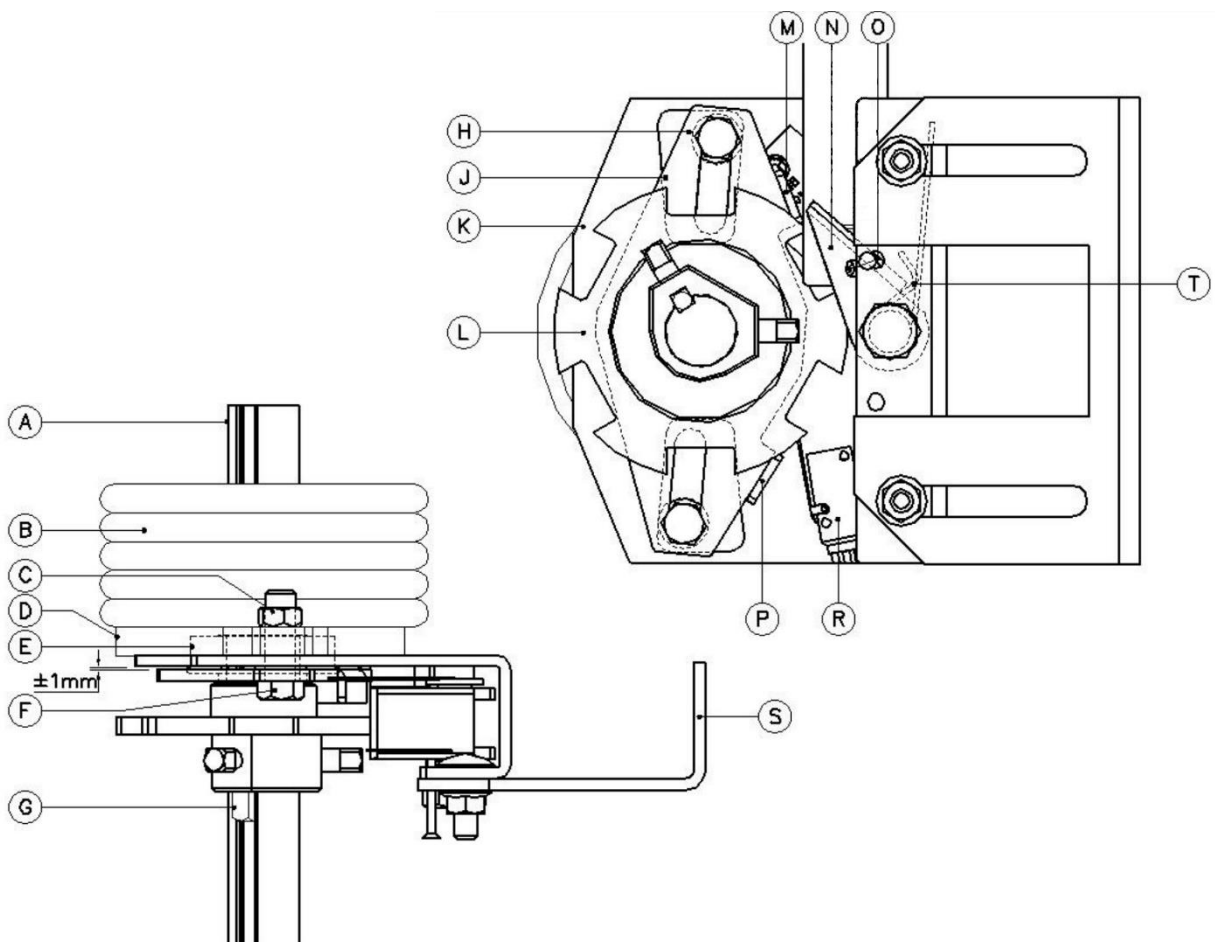

INSTALLATION – TORSION SPRING

Please note:

a) The stationary fitting (D) has to turn freely around the bearing (E). If necessary, widen the hole of the fitting.

b) The spring fitting (D) and blocking plate (J) must have a play of 2 mm which is created by the distance rings (H) and must be free of the centre plate (K).

1) Install the central plate (K) on the door frame/support beam where normally the centre bearing plate is installed. If the centreline is over 86 mm utilise the adjusting plate (S).

2) Fix the pawl wheel (L) with help of the set screw(s) and a 1/4" key of 30 mm minimum length. Max. torque 10 Nm.

3) Wind the torsion spring (B) in the prescribed usual way. All torsion springs on one door must be given an equal number of turns.

4) If available, remove the temporary blocking of the pawl. The pawl must be pushed to the lip (M) of the blocking plate by the small double torsion spring (T).

INSTALLATION – PANEL FITTING

Door Panel Fitting



Safety Notice:

Select the lowest torque to fix TEK screws on panel.

No Pitch Resistant Panel Type:

with single rail

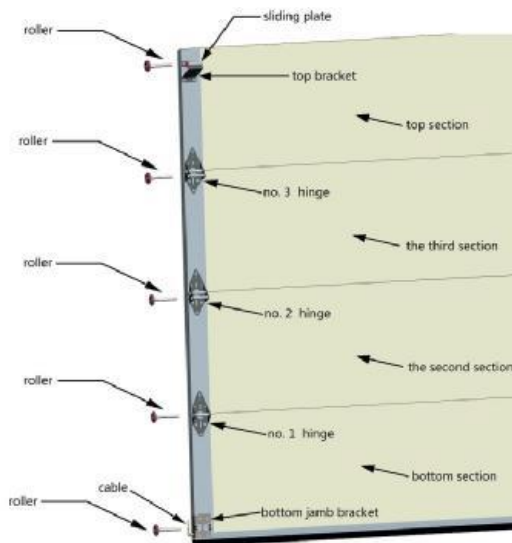

with double rail

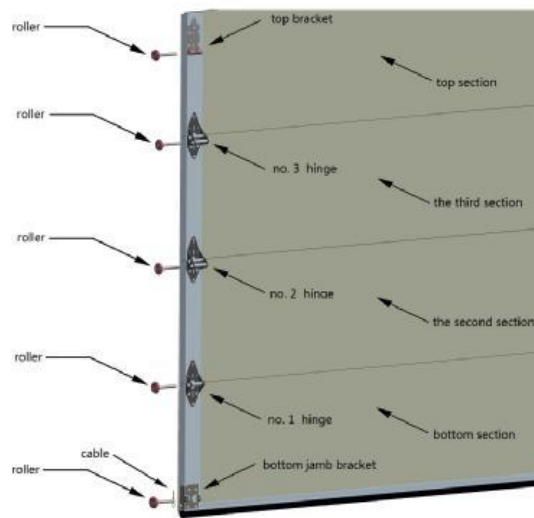

INSTALLATION – PANEL FITTING

Pitch Resistant Panel Type:

with single rail

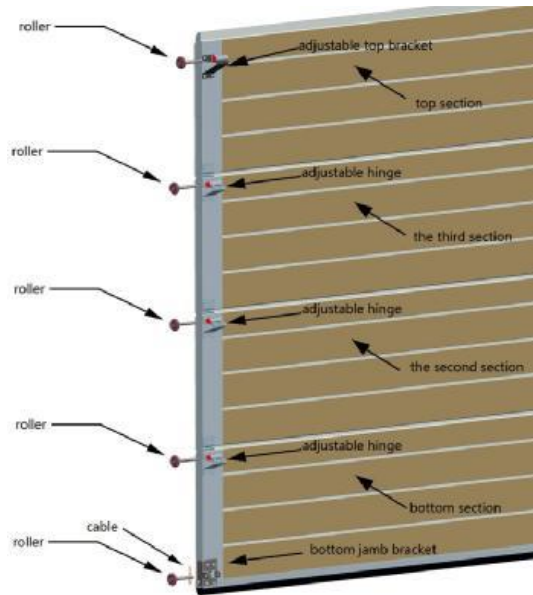

with double rail

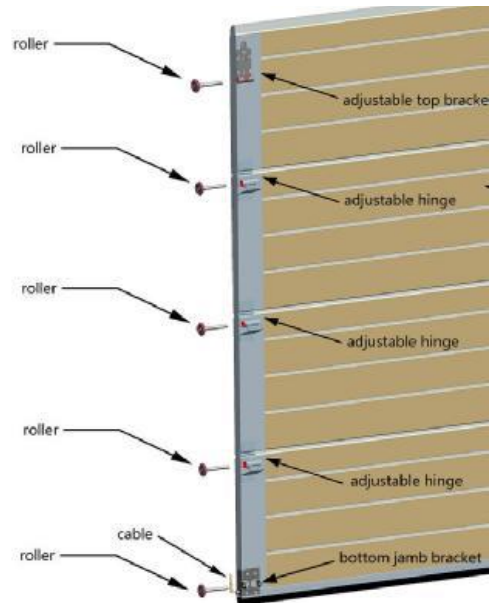

INSTALLATION – PANEL FITTING

Lower door panel

1. Lay the first panel onto the two stands covered with cardboard or carpet and fit the floor seal tightly onto the lower (recessed) edge of the panel. Drill and rivet the floor seal on at each end and at 300mm intervals into the centre. Slide the black rubber seal into place.
2. Lift the panel into position an equal overlap each side and temporarily brace.
3. This panel needs to be level to set a base for the door assembly. Use packers/shims to level the panel.
4. Position the lower door bracket (with cable trunnions) with roller installed into the track – as close as possible to the bottom, and tek screw.

No-Pitch-Resistant-Panel-Type:

Tek screw the #1 door hinges (c/w roller in track) to the top edge each side of the panel.

Pitch-Resistant-Panel-Type:

Tek screw the door hinges (c/w roller in track) to the top edge each side of the panel.

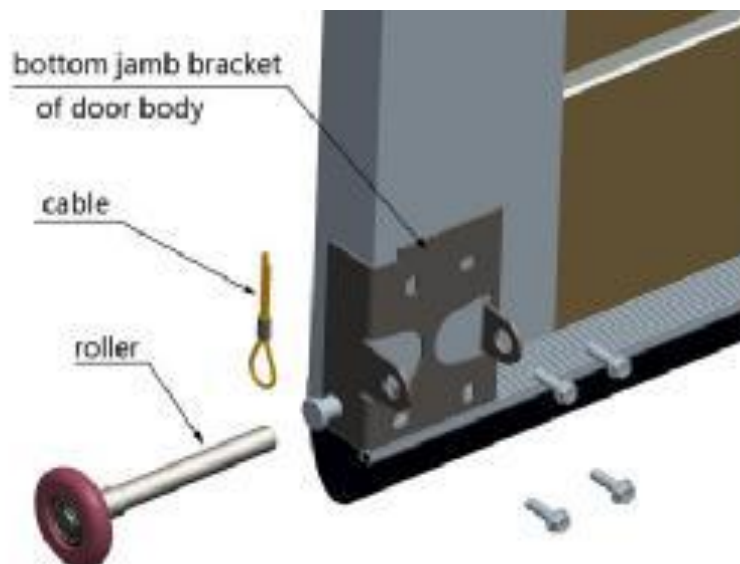

INSTALLATION – PANEL FITTING

Second and third door panel

1. Lift second door panel into position on top of the lower panel. Adjust panel until even protrusion at each end, and secure lower hinges to second panel.

No-Pitch-Resistant-Panel-Type:

Tek screw the #2 door hinges (c/w roller in track) to the top edge each side of the panel. Repeat steps for third panel using #3 hinge, and if necessary, the fourth panel using the #4 hinge.

Pitch-Resistant-Panel-Type:

Tek screw the door hinges (c/w roller in track) to the top edge each side of the panel. Repeat steps for third panel, and if necessary, the fourth panel.

Top door panel

1. Only Frame Door Type: Lay the last panel onto the two stands covered with cardboard or carpet and fit the top seal.

2. Lift top door panel into position on top of the third panel. Adjust panel until even protrusion at each end, and secure lower hinges to the top panel. Support the top panel temporarily.

3. Adjust the vertical tracks inward to close the door gap to 2-3mm. Adjust the horizontal track to align with vertical track.

INSTALLATION – PANEL FITTING

No-Pitch-Resistant-Panel-Type:

Assemble top roller bracket and insert into the track. Set roller bracket adjustment to allow the bracket to be fastened to the top panel as high as possible (to enable quicker turning when opened).

Pitch-Resistant-Panel-Type:

Assemble top roller bracket and insert into the track. Set roller bracket adjustment to allow the bracket to be fastened to the top panel as high as possible (to enable quicker turning when opened).

Centre hinges

No-Pitch-Resistant-Panel-Type:

Use the #1 hinge for all centre hinges. Evenly space the centre hinges and fasten with Tek screws.

Pitch-Resistant-Panel-Type:

Use the small hinge for all centre hinges. Evenly space the centre hinges and fasten with Tek screws.

INSTALLATION – SPRING SYSTEM



Safety Notice:

Read this section carefully and take all precautions.

Cable drums and cables

1. Thread one end of each cable through the alloy ferrule and then back into the ferrule with no loop on the bend. Set 5mm cable protrusion from exit of ferrule. Hammer alloy ferrule flat to lock cable.
2. Thread the other end of each cable through the alloy ferrule and then back into the ferrule with a 25mm loop on the bend. Set 5mm cable protrusion from exit of ferrule. Hammer alloy ferrule flat to lock cable.
3. Run the loop end down the inside of the vertical track - side mounting brackets, and onto the lower panel cable trunnion.
4. Start on the Left-hand side drum –Fit the top end of the cable into the cable drum slot and rotate the drum to coil the cable and hold tight while tightening the drum set screws.
5. Fit the vice grips (locking pliers) to the shaft and wedge against the wall to prevent the shaft from turning, and the cable from unwinding.
6. Attach cable to the Right-side drum and hold tension on the cable while tightening the set screws.

INSTALLATION – SPRING SYSTEM

7. Check that both cables are correctly positioned, and equally tensioned. Then tighten the two (2) lock screws on each drum very tightly. The screws must bite into the axle pipe to prevent them from releasing when the door weight is applied. Tighten one drum screw then the other until no more movement can be applied with a 10mm spanner.



Safety Notice:

Wear safety glasses and leather gloves when tensioning.

Work from a steady ladder when performing this task.

Tighten the spring end lock screws very tightly before releasing the bars.

The springs when tightened have stored energy and can cause injury.

INSTALLATION – SPRING SYSTEM

Spring Tension

Tension the springs by inserting the adjustment bars into the spring end, then lift the bar toward the ceiling to tighten.

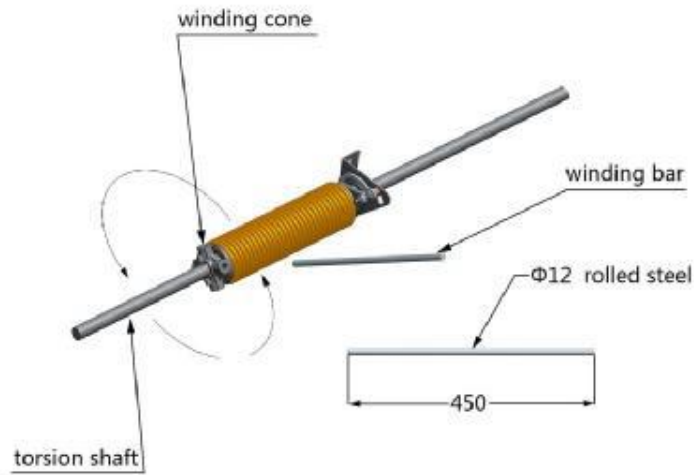

The spring end has four (4) adjustment sockets. Insert next bar into the spring end before releasing the first. Use a 10mm open end spanner to tighten the spring end lock screws very tightly before releasing the bars.

1. Tension each spring - The spring/winding cones should then be turned (tensioned) approximately 6-7 full turns (for 2.1 m height) Each additional turn equals 0.3m height.
2. Tighten each spring bolt tightly and evenly before removing the bar once tensioning is complete.
3. Carefully release the Vice Grips and check the door. If the door feels very heavy to lift or alternatively 'springs up' then the springs will need to be adjusted so that the door feels 'neutral' or just raises slightly from the floor.
4. Retighten all lock screws on the cable drums and spring cones very tightly.

INSTALLATION – MOTOR TRACK

Door movement

- Check the tracks are adjusted and secure.
- Check the tracks are parallel overhead. Adjust as required.
- Open the door by hand until the lower door floor seal is level with the top of the door opening only --- and NO further, as cables may jam.
- Repeat several times to check axle wheels are running freely. Adjust axles or tracks as required. It is good practice to lubricate all hinges and rollers with a silicon spray.

Motor Track

Please note: All motor and track mounting brackets in motor box.

Front Mount

Mark the centre of the door opening. Fit the motor track mounting bracket to the centre line mark – as close to the ceiling lining as possible. Recommend the use of four 4mm x 50mm wood screws for wooden framed ceilings.

Fit the motor track to the front mount.

INSTALLATION – MOTOR TRACK

Rear Support Mount

Fit the single U-shaped mounting bracket and the 200mm angle bracket (2 x M8 bolts / nuts) to the track.

Mark the motor track mounting position 90 degrees with the centre of the door opening. Lift the track up to the mounting position and measure the length of the vertical braces needed to connect the 200mm brace to the ceiling overhead support. Lower track and cut bracing to length.

Lift track and mount as close to the ceiling as possible. Do not fit motor at this stage.

Motor & Track Assembly

1. Ensure the track trolley (1' in right hand drawing below) is contacting the track stop in front of the motor mount, move trolley back if required. Connect the straight link to the trolley pin (2).

2. Secure the motor linkage plate at the centre of the top panel with four (4) tek screws. Set screwdriver driver to lowest setting to install tek screws. Do the final tighten of the screws by hand.

3. Connect the curved link to the door bracket (7) and then to the straight link (5). Tighten linkage bolts (3,4) Lift up the drive motor into the track drive spline (4, below), and secure with the two (2) overhead clamps. Ensure Black aerial wire is loose.

INSTALLATION – MOTOR WIRING



Safety Notice:

DO NOT CONNECT POWER CORD

Wall Mounted Control Wires

1. Ensure power cord is not connected.
2. Remove the motor cover (loosen the exterior screws) and install the in-house opening control wires (if fitted). Connect the wires to the PCB of the motor.
3. If there is no in house wall mounted switch wiring, use the switch and wire (if supplied).
4. Refit the cover.



Safety Notice:

Final check before connecting power cord:

- Check all fastenings are tightened.
- All hinges are fitted and secure.
- Check all axle wheels are adjusted and tightened.
- Check all tracks are secure and braced.
- Clear all tools and parts from door area.
- Important: Clear all personnel from door area

INSTALLATION – MOTOR SETTINGS

Motor Adjustment



Safety Notice:

Clear all personnel from door area before programming the motor. Keep hands off tracks.

For adjustment of end position and force please refer to the motor manual.

Testing Safety Rebound Feature

1. Open the door and place a solid object at least 400mm high on the floor under the door.
2. Close the door and watch the door contact the object and rebound away. If the door exerts too much downward pressure on the object, the setting can be adjusted as per motor manual.

Custom Settings for Door Opener Motor

The garage door should be ready to use at this point, the following adjustments are for custom settings only. For custom adjustment of end position and force please refer to the motor manual.

Maintenance and repair

Please inspect the automatic reversal and the door balance monthly and adjust it if necessary.

TROUBLESHOOTING GUIDE

PROBLEM	REASON	SOLUTION
Door can't stop in every position, can't be opened completely.	Preload of torsion spring is too low.	Add tension on the torsion spring.
Door gets very heavy during opening and opens only halfway.	The torsion spring(s) has been installed backwards.	Re-install the torsion spring.
Door opens very fast and is hard to bring back down.	Preload of torsion spring is too high.	Remove tension from the torsion springs.
Door closes fast and is hard to lift.	Preload of torsion spring is too low.	Add tension on the torsion spring.
Door works well but it goes back up 2 to 3 inches.	Preload of torsion spring is too high.	Remove tension from the torsion springs.
Door is hard to open at the beginning.	Weather strip is too close to the panel.	Loose weather strip and fix it in a distance of 10mm.
Door is hard to open at the end.	The horizontal tracks are not perpendicular with the axis of the door.	Cross check dimensions, adjust tracks.

TROUBLESHOOTING GUIDE

PROBLEM	REASON	SOLUTION
Top panel does not close completely.	Position of upper bracket incorrect.	Adjust the position of the upper brackets.
The door slanting as it moves.	The lifting cables have different length.	Readjust the cable length.
Noise during operation.	Hardware is not fully tightened.	Tighten all screws.
	The traction bracket of the motor is not aligned with the door centre.	Adjust position of the bracket to align it with door centre line.
	The two side tracks are not parallel to each other.	Adjust level of vertical tracks to get them parallel.
	Roller and cable drum not greased.	Grease roller and cable drum.
The opener does not work.	No electrical power.	Connect to electrical power.
Door stops before it is fully up on opening cycle; or door auto reverses before reaching the ground on closing.	The closing resistance is greater than the auto rebound system.	Inspect and adjust the door balance system.

TROUBLESHOOTING GUIDE

PROBLEM	REASON	SOLUTION
Door does not fully close or open.	The travel position adjustment is not suitable.	Re-adjust limit position.
Push button can operate normally, but not remote control.	Remote control has not been set correctly or it has no battery. Flat battery in the remote control.	“Learn” transmitter according to the manual. Change the battery of remote control.
The remote control has short range, or the brightness of indicator lamps have become dimmer.	The signal to the motor is getting shielded by the garage. The battery power is not enough.	Draw the antenna to the outside of garage. Change the battery.
Remote can operate normally, but the push button has no function	Push button loose or broken circuit.	Inspect push button wiring.

MOTOR TECHNICAL DATA

Motor Technical Data

Power supply: AC 230/240 V or 110/120 V, 50/60 Hz

Standby approx. 5W

Protection category: For dry rooms only

Push and pull force: 600N / 800N / 1000N / 1200N.

Input power: 120W (in operation with lighting)

Motor: DC 12V

Transformer: With thermal overload protection

Connection: Connection for external equipment with safe low voltage of 24 V DC, e.g. push buttons for impulse control.

Special functions:

- Quick release: In the event of a power failure, actuated from the inside via a pull cord.
- LED operator lighting (automatic switch off after approx. 180 seconds)
- Photocell can be connected.
- Universal fitting: For up-and-over and sectional doors.
- Door speed: Approx. 12 cm/s (depending on size and weight of door)
- Remote control: 2-button hand transmitter.
- Remote distance: $\geq 30\text{m}$

Remote frequency: 433.92MHz

Ambient operating temperature: $-20^{\circ}\text{C} \sim +55^{\circ}\text{C}$

REPAINTING DOOR PANELS

Repainting door panel

- To repaint panel surface, lightly sand the surface with fine sandpaper (at least 180 grain size).
- Clean with water, dry and remove any grease - treat further with commercially available synthetic resin paints suitable for outdoor applications.
- Avoid dark coatings on double-skinned doors and doors
- Follow the directions of the paint manufacture

Dismantling

Method:

Dismantle the door in accordance with these fitting instructions, in the logically correct reverse order.

TRIMMING DOOR PANEL SIZE

Tools Required

QUANTITY	TYPE
1	Black Marker Pen.
1	Square.
1	Power cord.
1	Electric Jigsaw or Circular Saw with Metal Blade.
1	Metal Cutting Jigsaw Blade at least 70mm long.
1	Rivet Gun.
1	Face dust mask, glasses and earmuffs.
1	Corrosion sealant / rust inhibitor.

TRIMMING DOOR PANEL SIZE

Method:

Measure daylight opening size of finished doorway, inside to inside measurement, or floor to the top of opening if shortening a door.

Width:

Add 40mm to the new width measurement of the door and use a black felt marker to mark a line square/perpendicular across the panels.

Support door panel on timber high enough for the jig saw cutting blade to operate and not contact the floor. Ensure a support is in place under the off-cut section.

Start cutting along the black line.

When cut remove end cap from off-cut and install onto door end. It is recommended that the cut ends be treated with corrosion sealant i.e. paint.

If your door is a cassette style you will need to trim an even amount off both ends to ensure the pattern remains centred.

Height:

Add 20mm to the new height measurement and mark across the top door panel with a black felt marker.

Support door panel on timber high enough for the jig saw cutting blade to operate and not contact the floor. Ensure a support is in place under the off-cut section.

Start cutting free hand along the black line.

A galvanized capping will need to be fitted (40mm x 30mm x 30mm) to seal the top end.

Place capping over top of the panel and rivet at each end and at 300mm intervals.