



LUNARES OUTDOORS™  
SAN FRANCISCO



## AQUOS PLANTER EXTRA LARGE

SKU #6033

**MATERIAL:** 100% Recycled Aluminum

### DRAINAGE:

- 3 holes - approx 1" diameter
- Custom size available to function with irrigation and draining

**FINISH:** Green  
Additional finish colors available

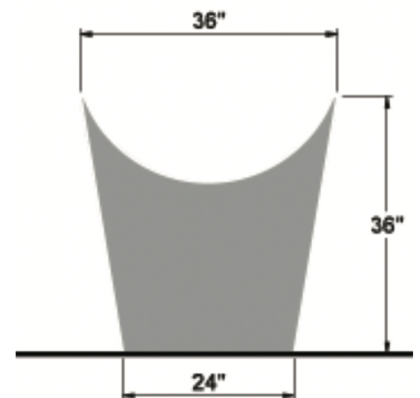
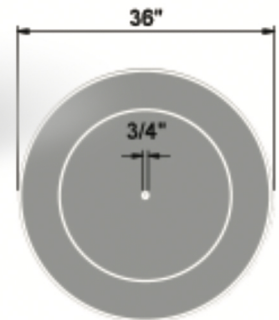

Aquos  
Planter, XLarge  
Sku#6033 p.17