

Linha dobrável

Mesa



montagem 1 pessoa



tempo 30 minutos



ferramenta chave phillips



ferramenta martelo



ferramenta martelo de borracha



meumóvelde madeira

www.meumoveldemadeira.com.br



ATENÇÃO

- 1- Leia e observe atentamente toda a instrução antes de iniciar a montagem.
- 2- A montagem do produto deverá ser feita em uma superfície limpa e plana. Aconselhamos utilizar a embalagem para forrar o chão a fim de não danificar o produto.
- 3- Os parafusos devem ser apertados periodicamente.
- 4- Evitar contato com objetos cortantes.
- 5- Evitar batidas.

FERRAGENS/ACESSÓRIOS

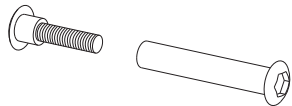
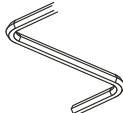
A		02
B		02

PARTES DO PRODUTO

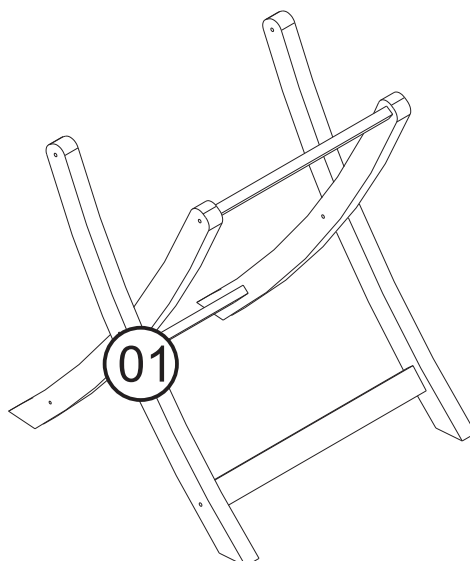
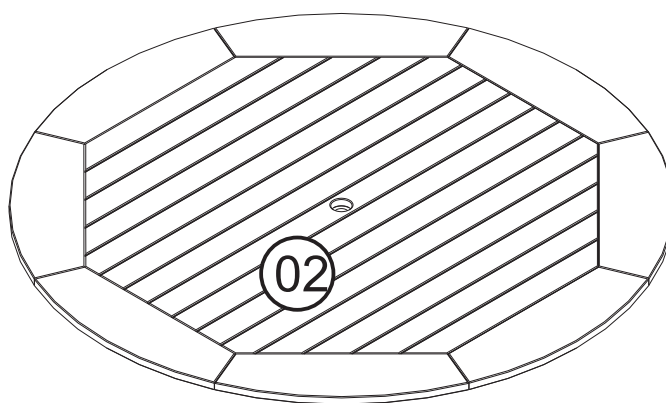

01

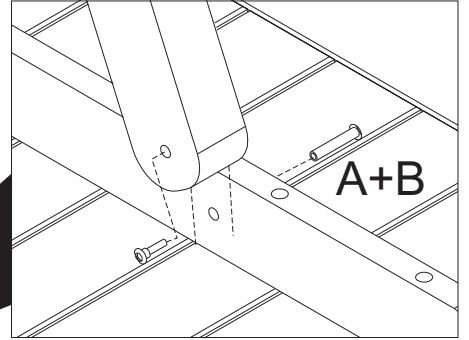
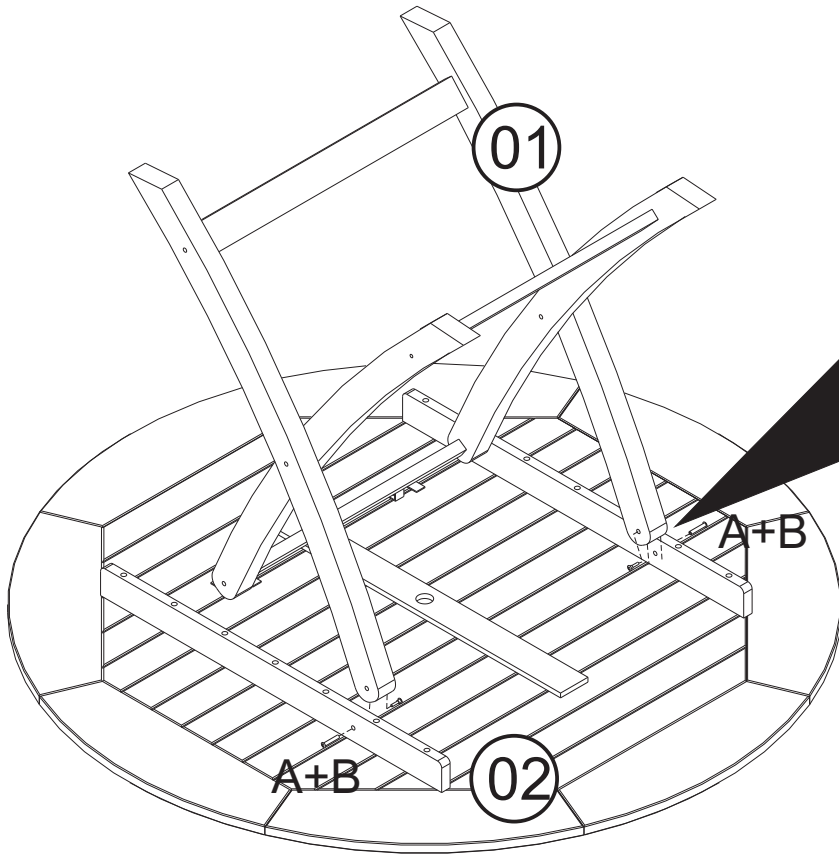
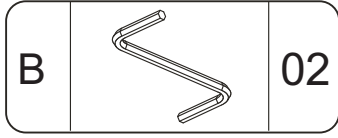
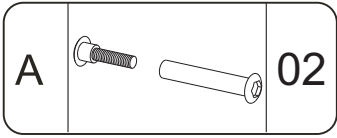

02

