

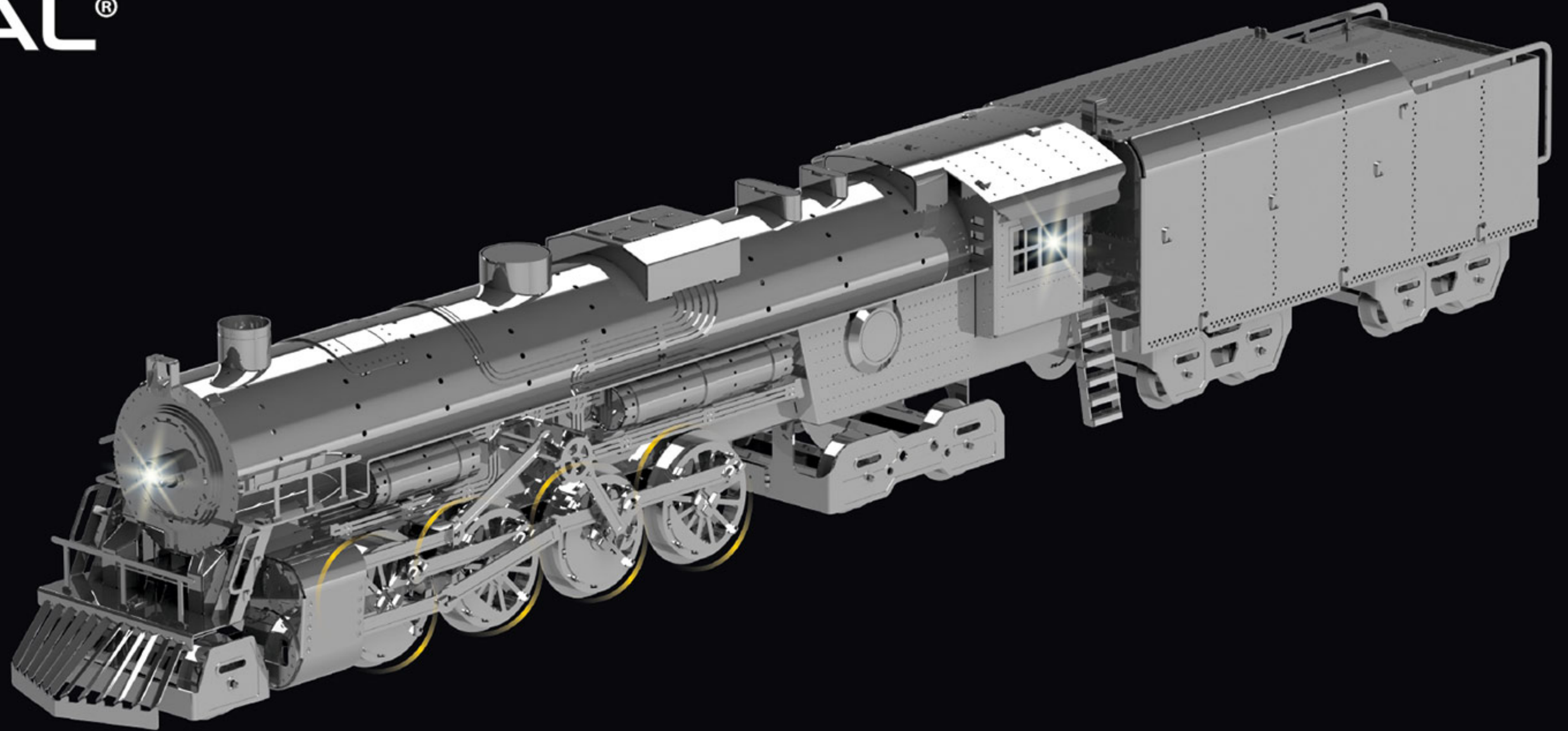

METAL<sup>®</sup>  
TIME



## POLAR STEEL

3D Metal Mechanical  
Model Building Kit

Assembly instructions

Collect the Best

**211** PIECES

**12** hours

Fully moving / Front spotlight  
Cabin illumination / Tracks

AGES  
**14+**

## STANDARD FIXING OF FASTENERS AND SYMBOLS

**WARNING!** Please read these instructions carefully before assembly and use.

When assembling the model, don't rush, avoid pointing details at yours or anyone else's face. If one of the parts has a sharp edge, please file it down. Use pliers and additional tools to assemble the model. Each kit contains a cloth for wiping and polishing the model once it's assembled.

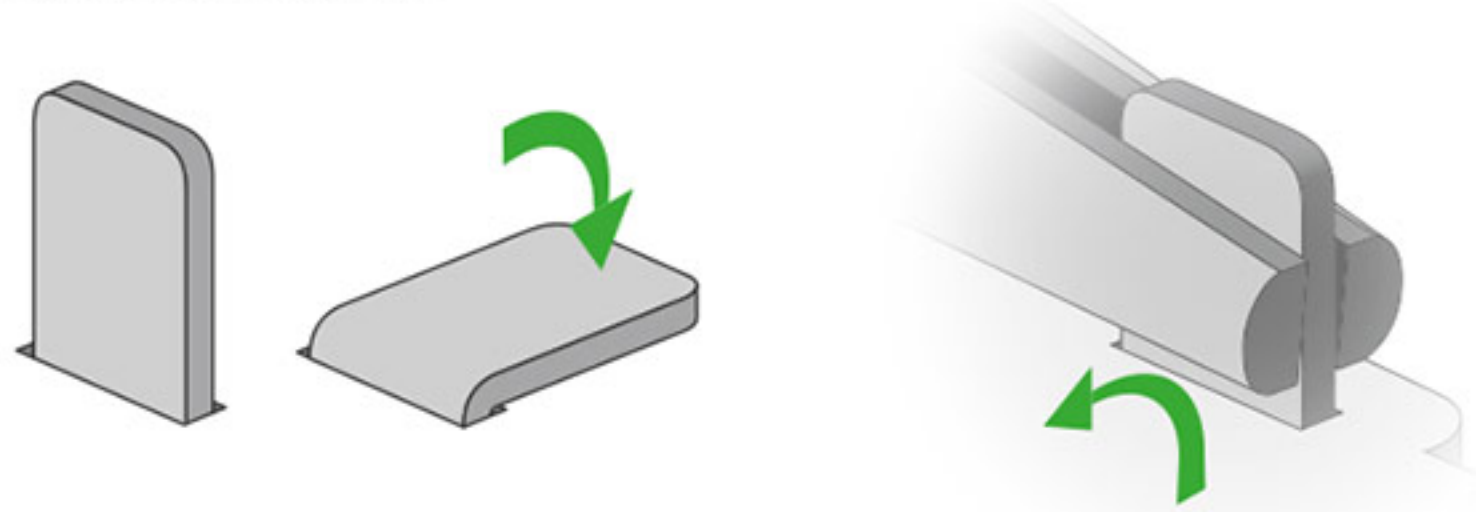

If there are no additional designations, use the standard fixing method

Use pliers to bend the fasteners



Twist the eyelet 45°

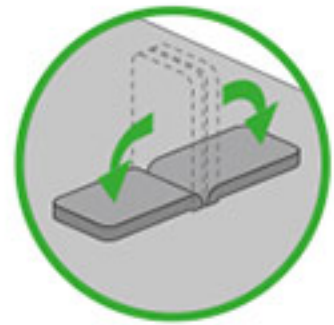

Bend the ears 90°



Assemble/bend parts symmetrically

**WARNING!** Product contains small parts and sharp parts. Not suitable for children under 3 years of age.

**WARNING!** To avoid a short circuit, the contact points must not touch the product body

## MODEL PARTS AND ASSEMBLY TOOLS

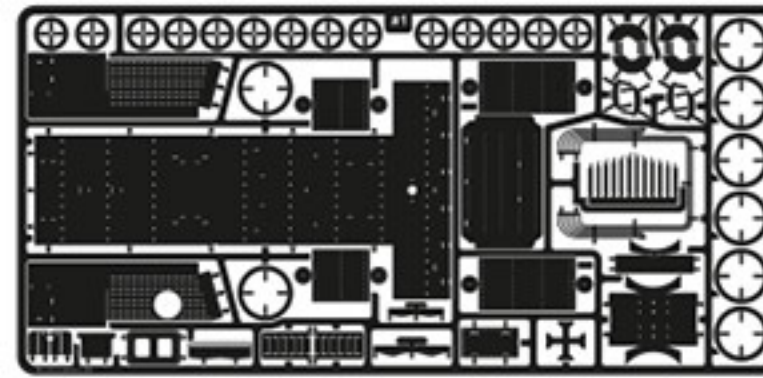

#1

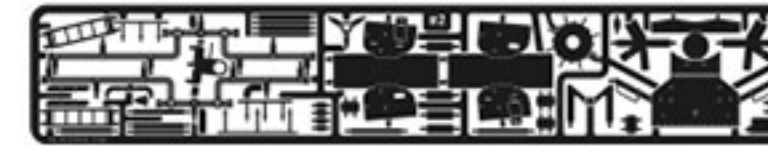

#2



#3

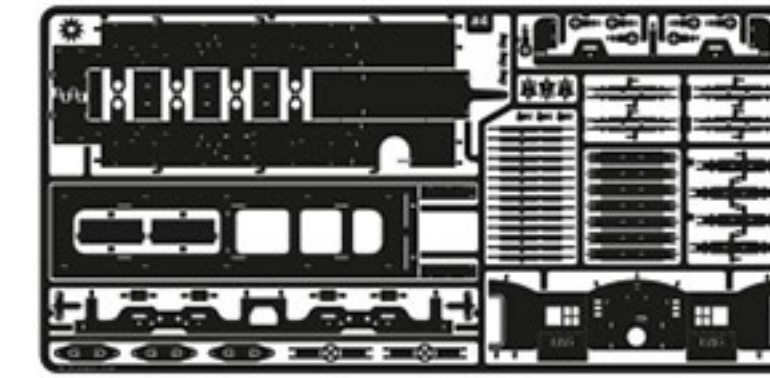

#4

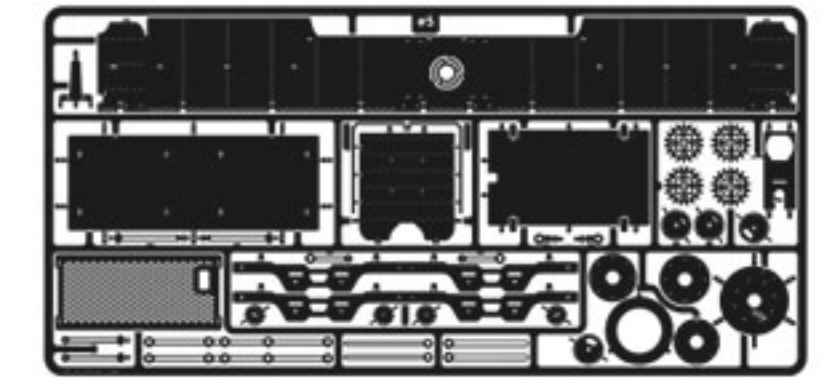

#5



x4



x4



x14



x3

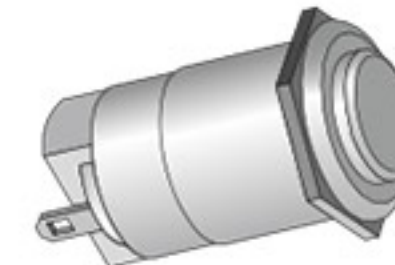

Button

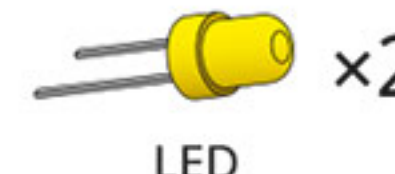

LED

x2



40 mm



40 mm



40 mm



70 mm



190 mm

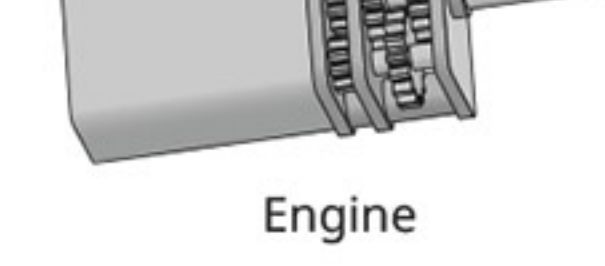
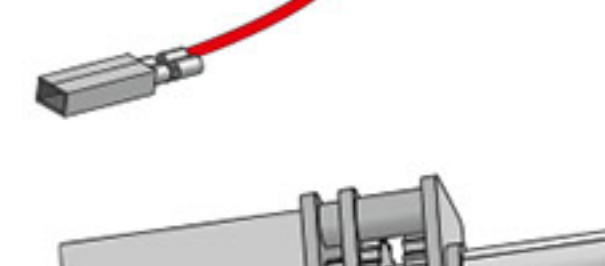
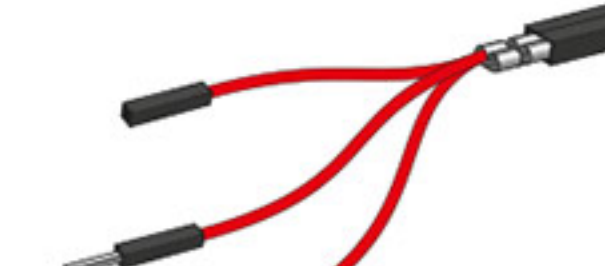

Engine

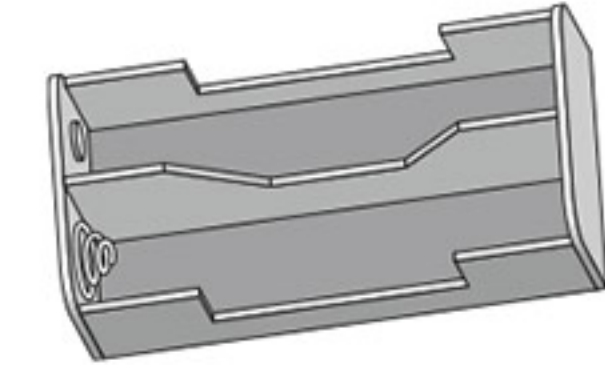

Battery holder

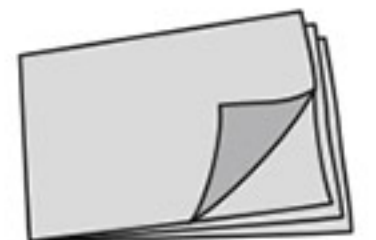
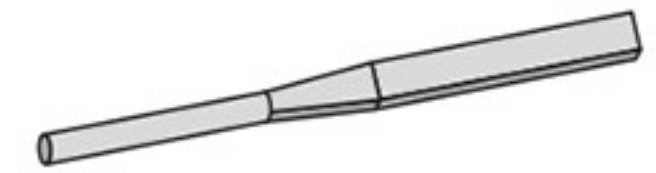
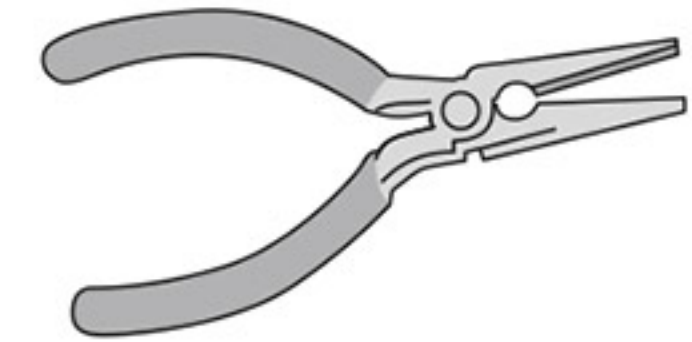

Tools

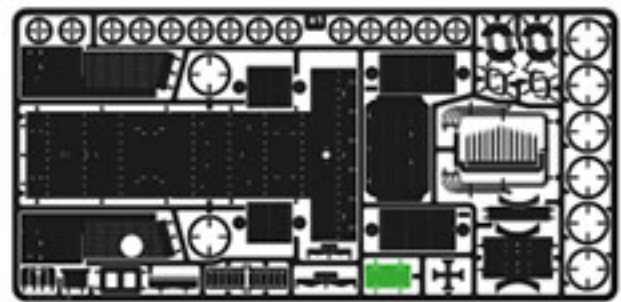

#1



#2

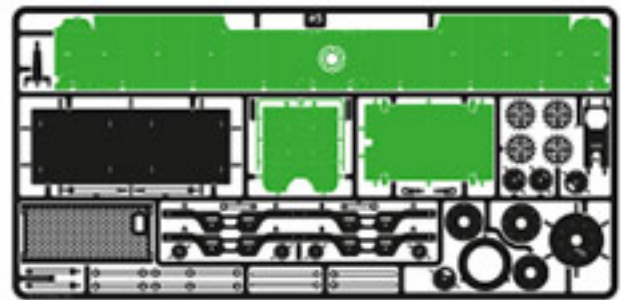

#5

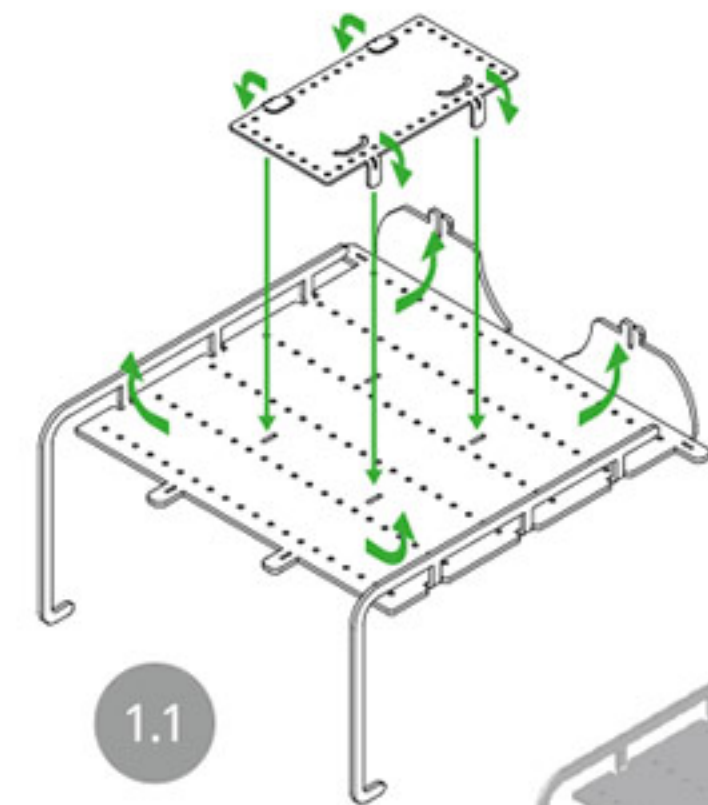

1.1

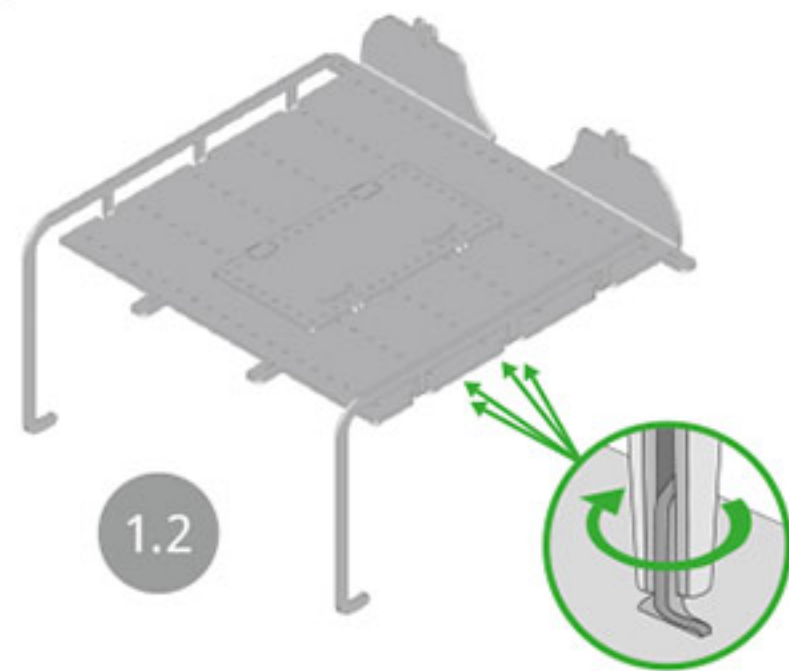

1.2

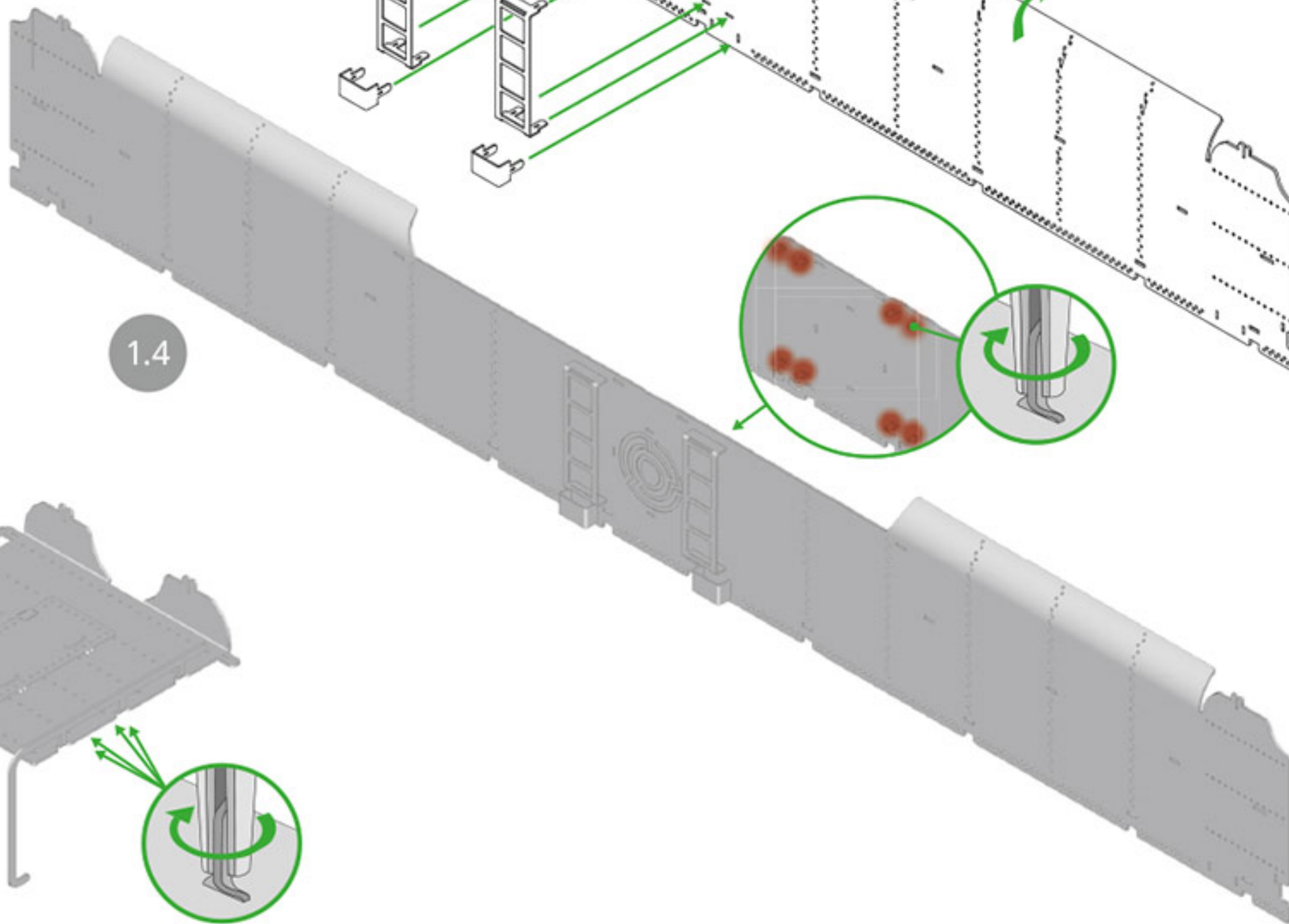

1.4

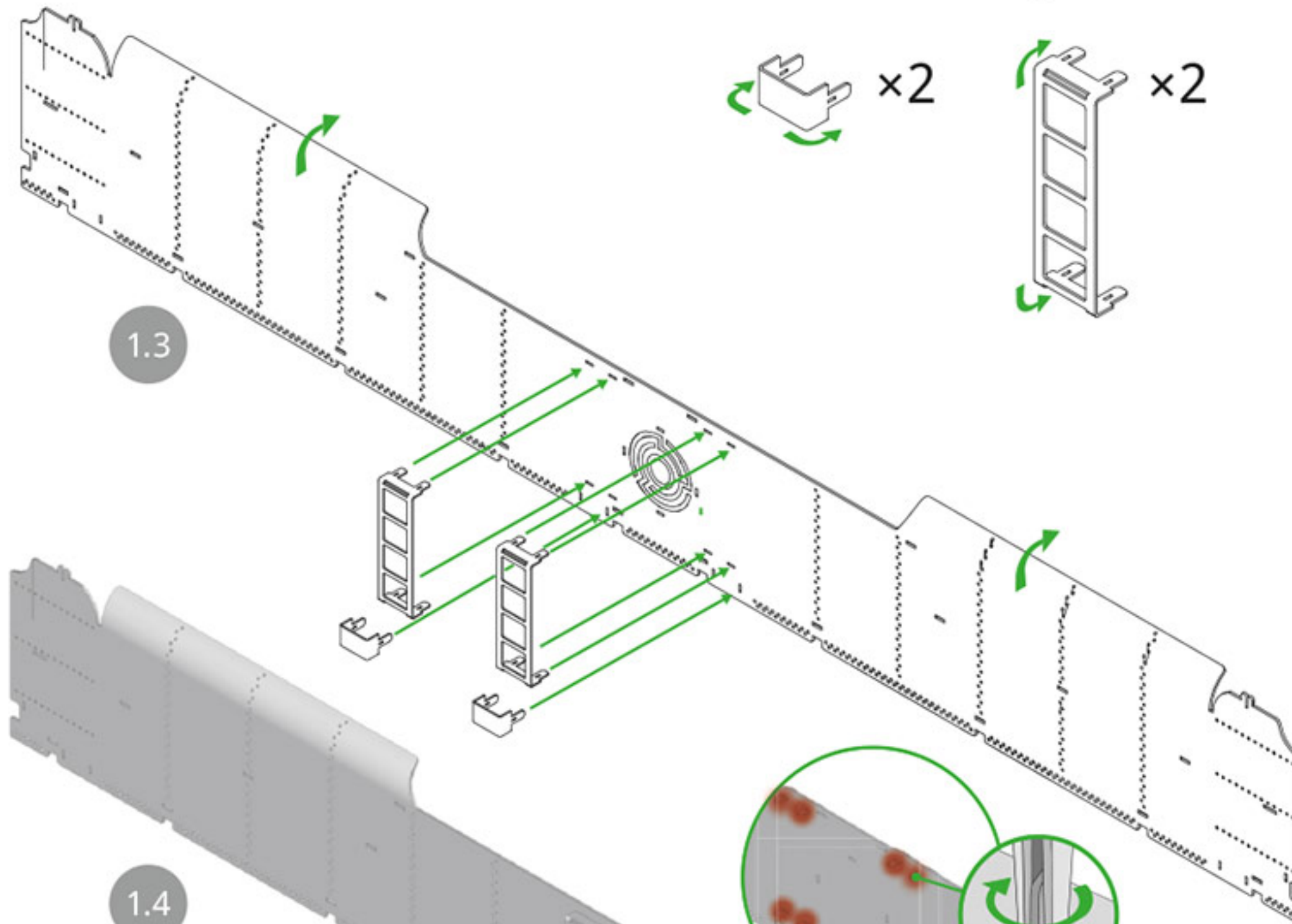

1.3

x2

x2

1.5

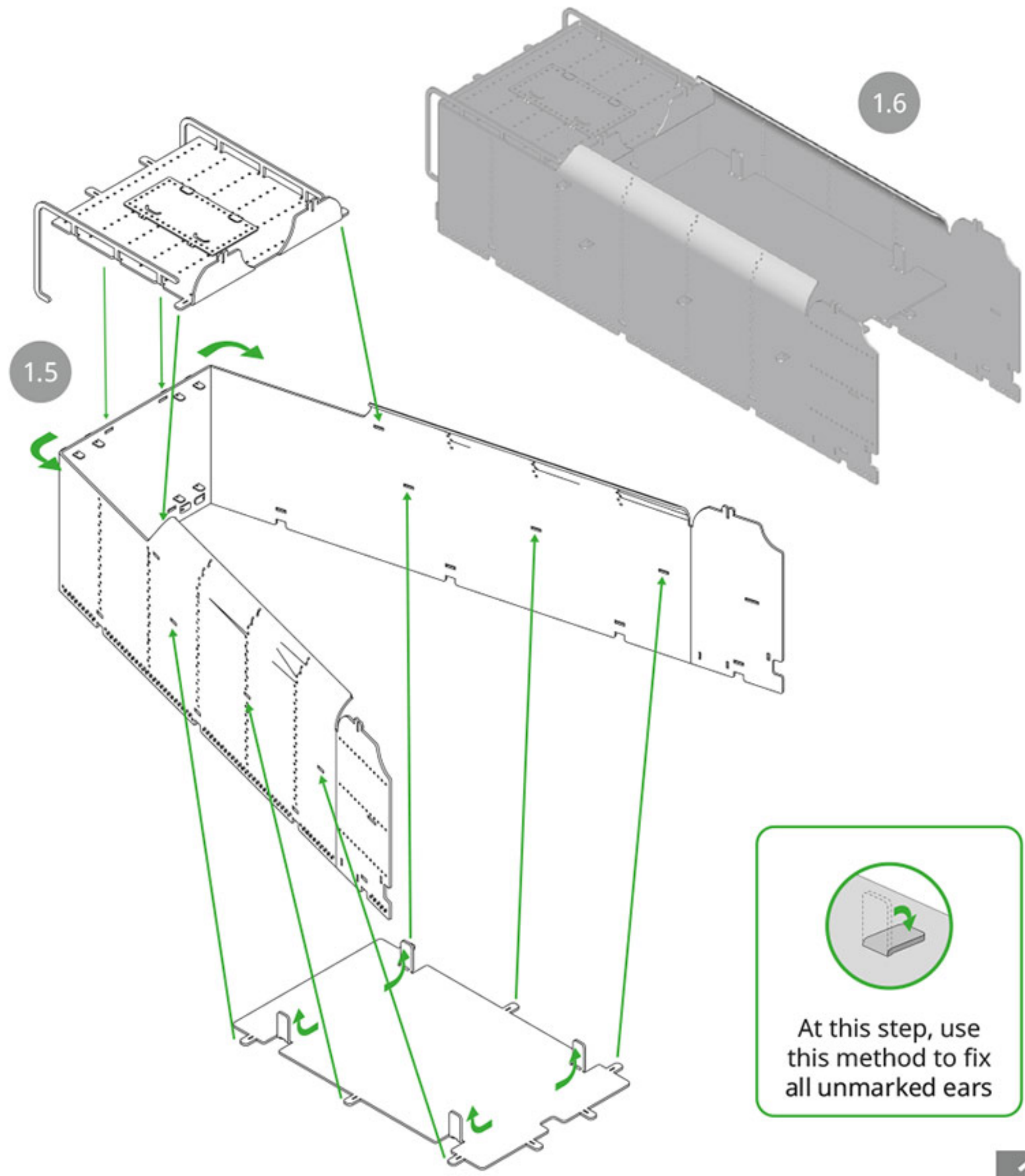

1.6



At this step, use this method to fix all unmarked ears

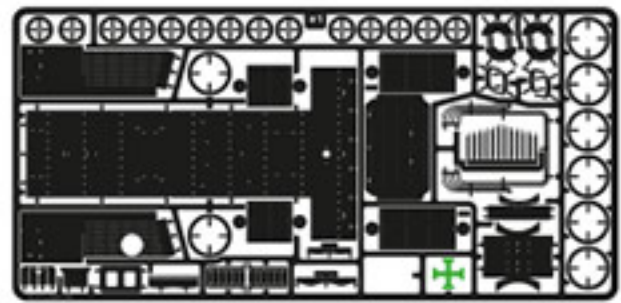

#1



#2

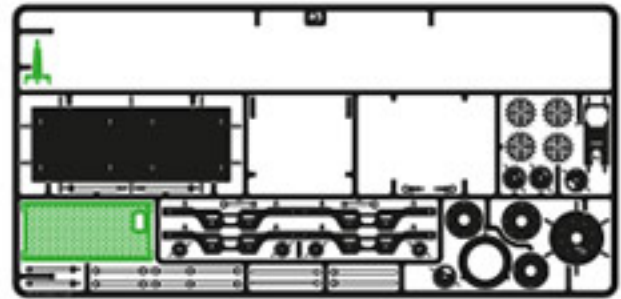

#5

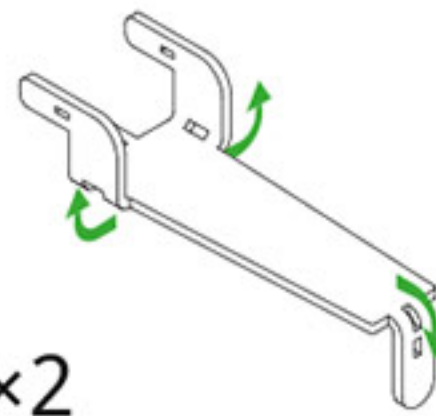
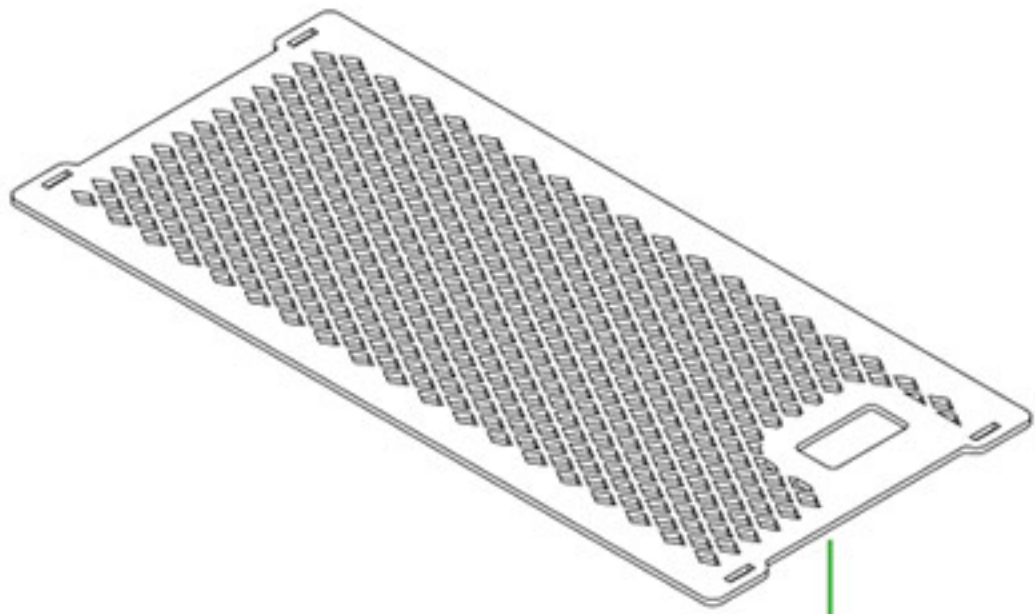

Battery box

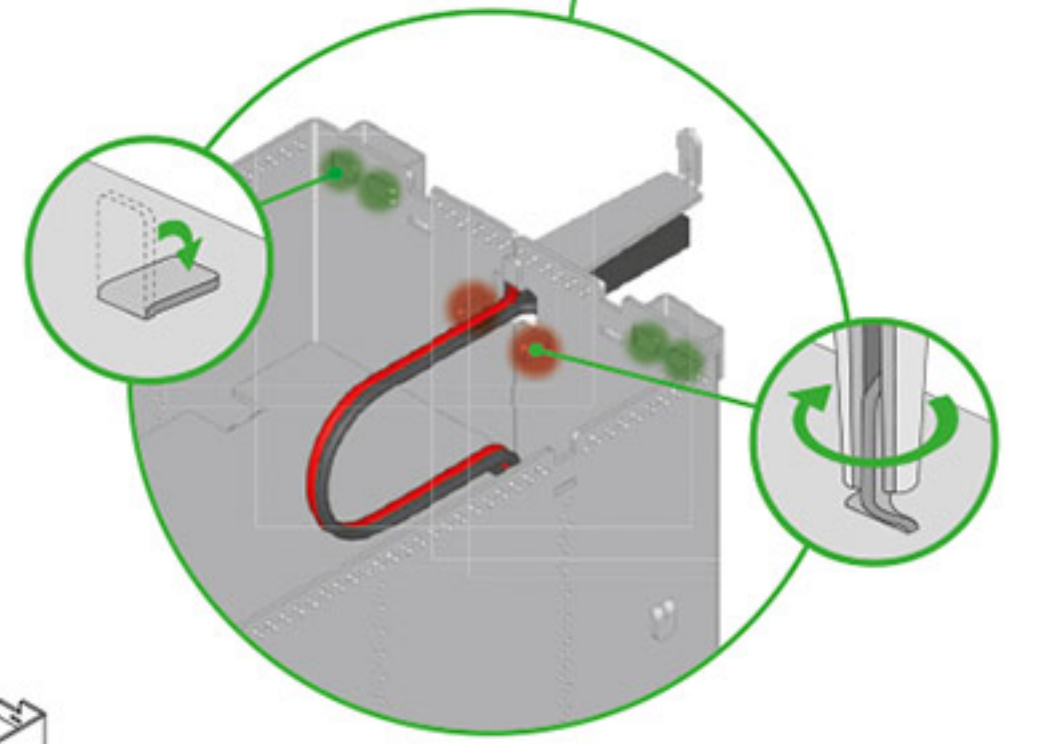
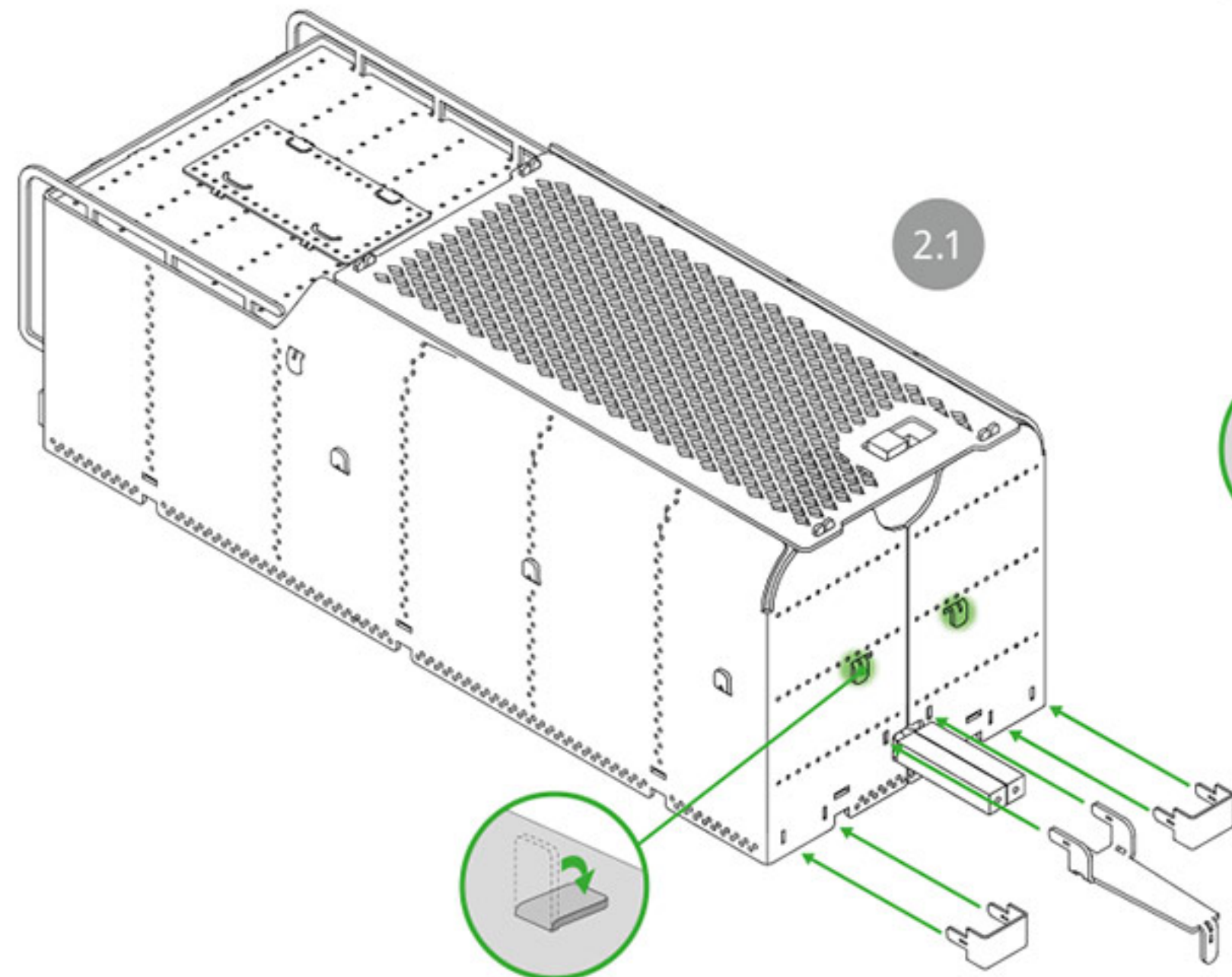
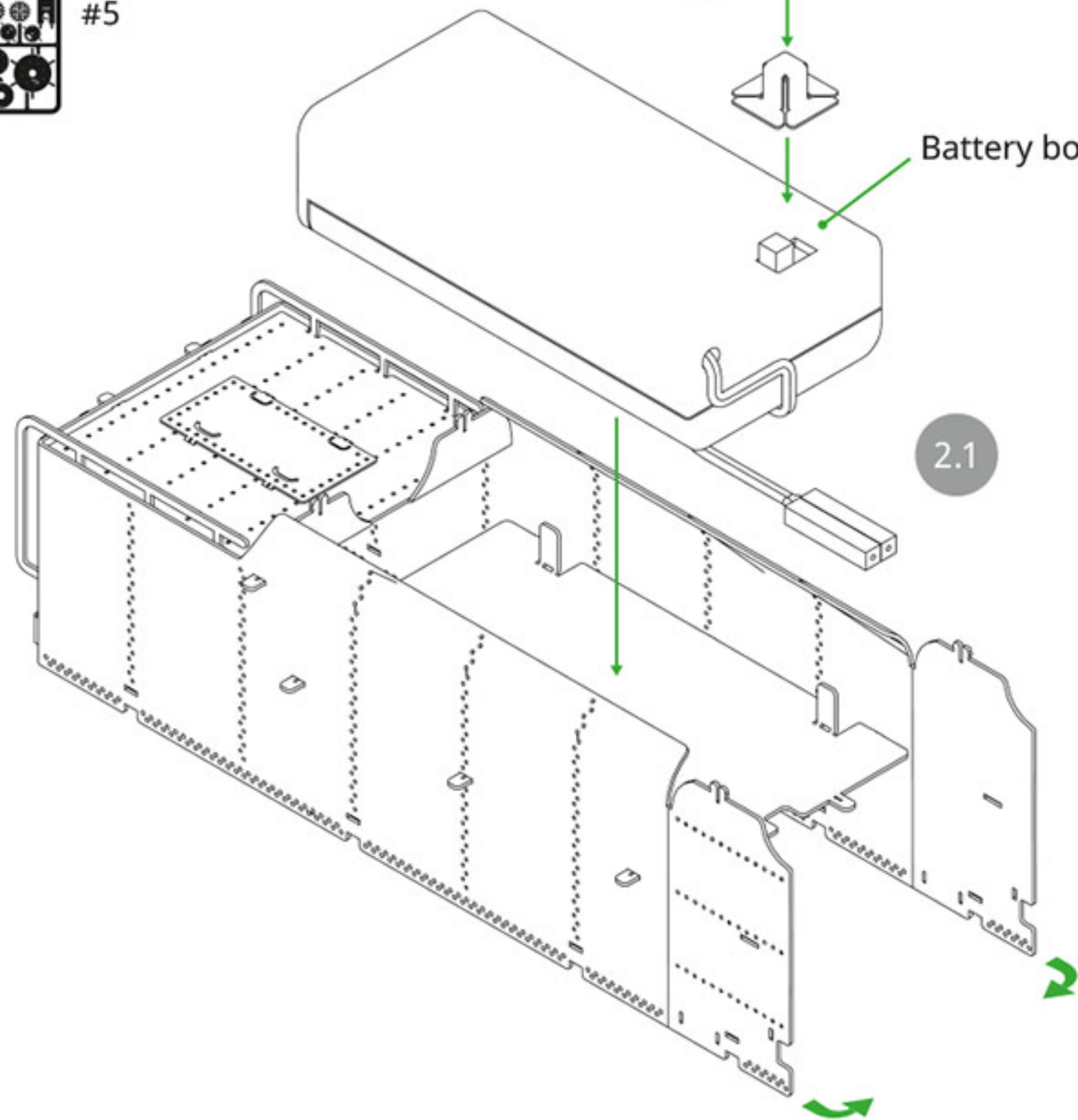

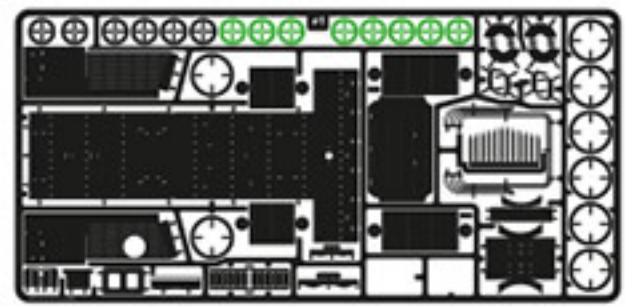

#1



#2

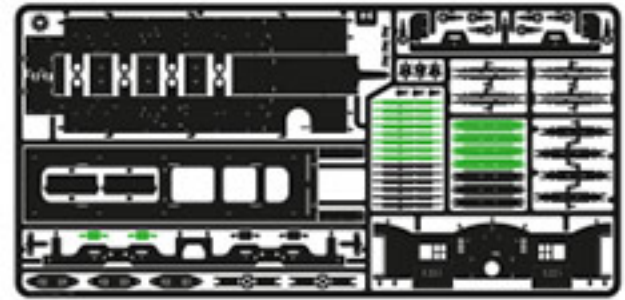

#4

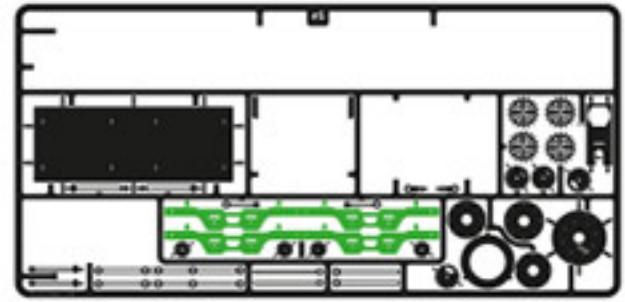

#5



x8

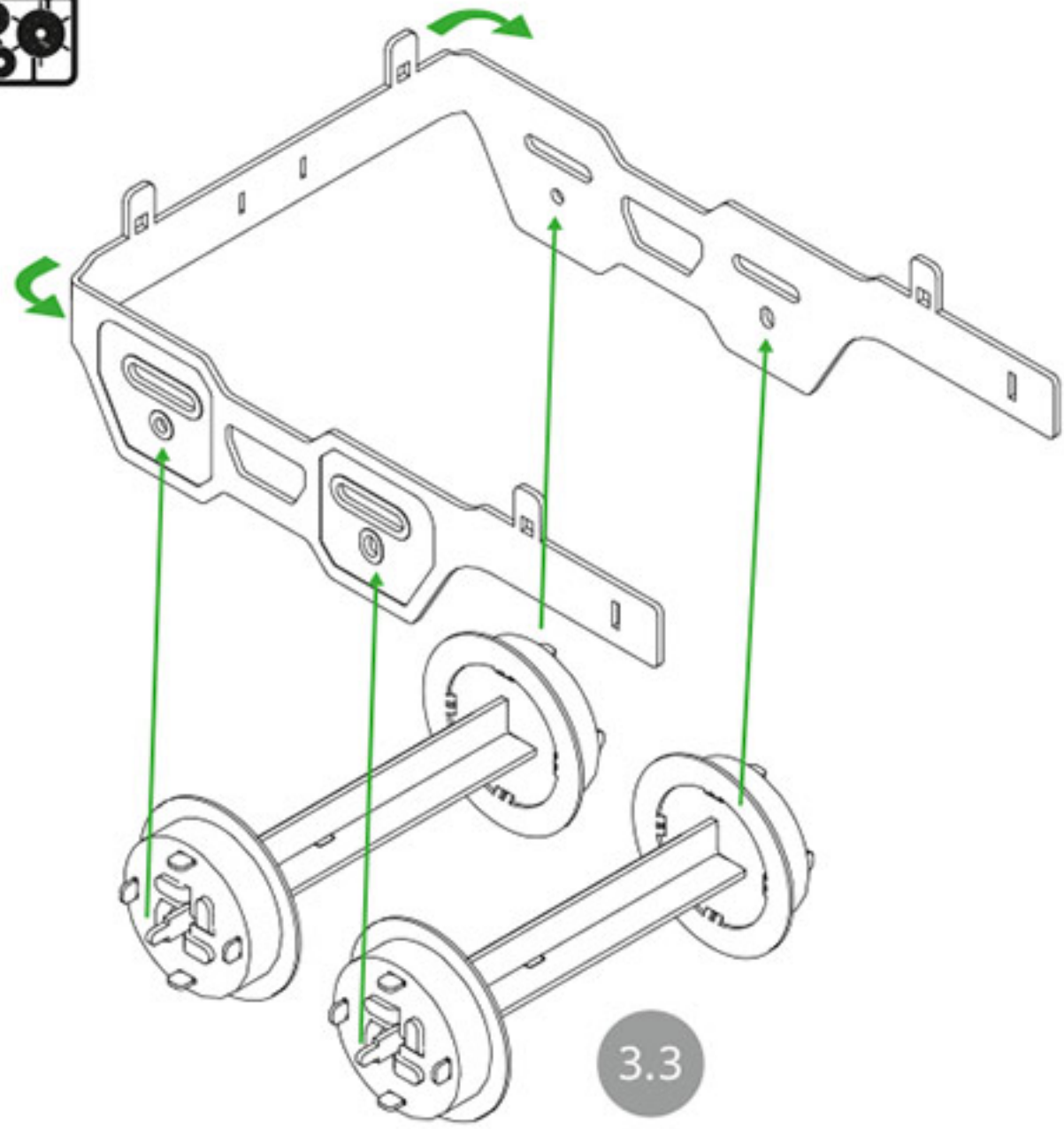

3.1

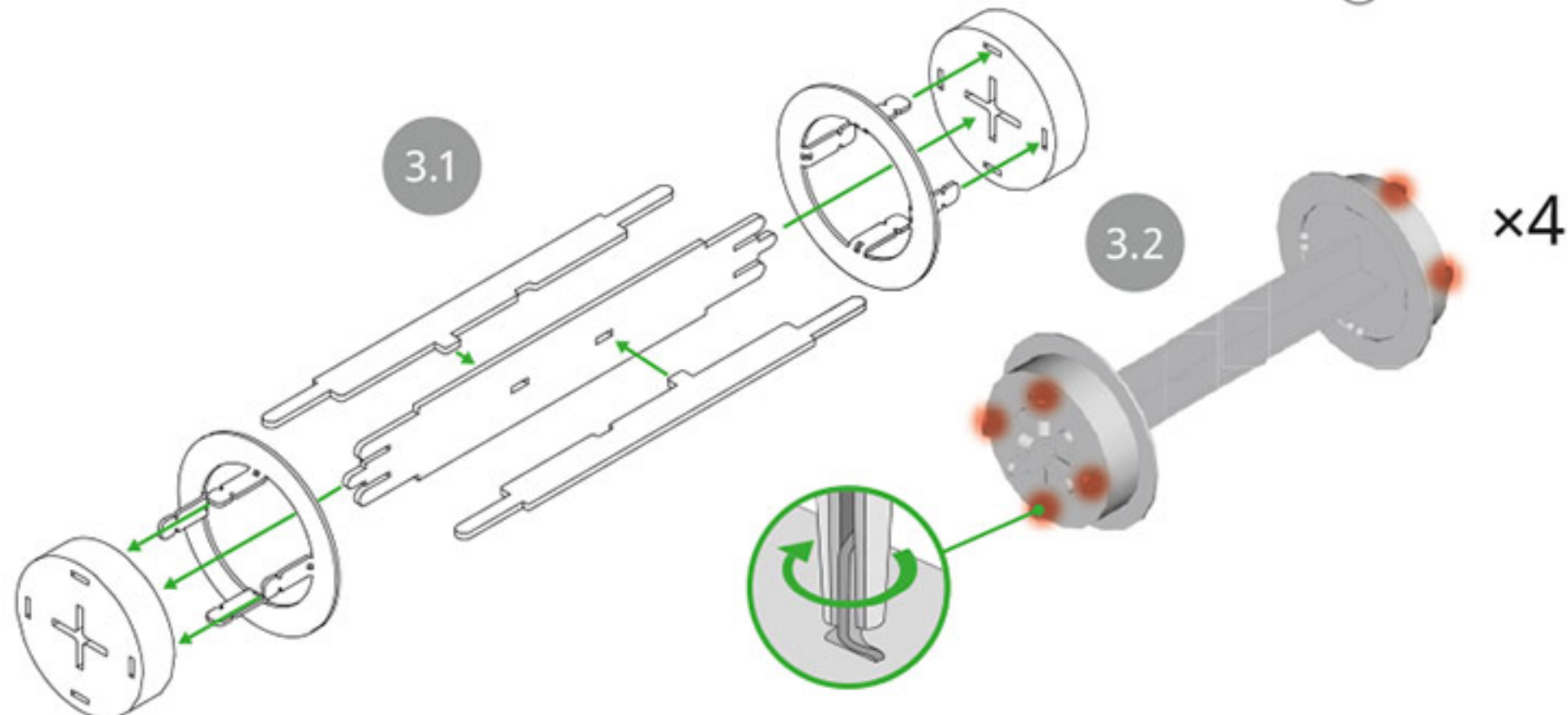

3.2

x4

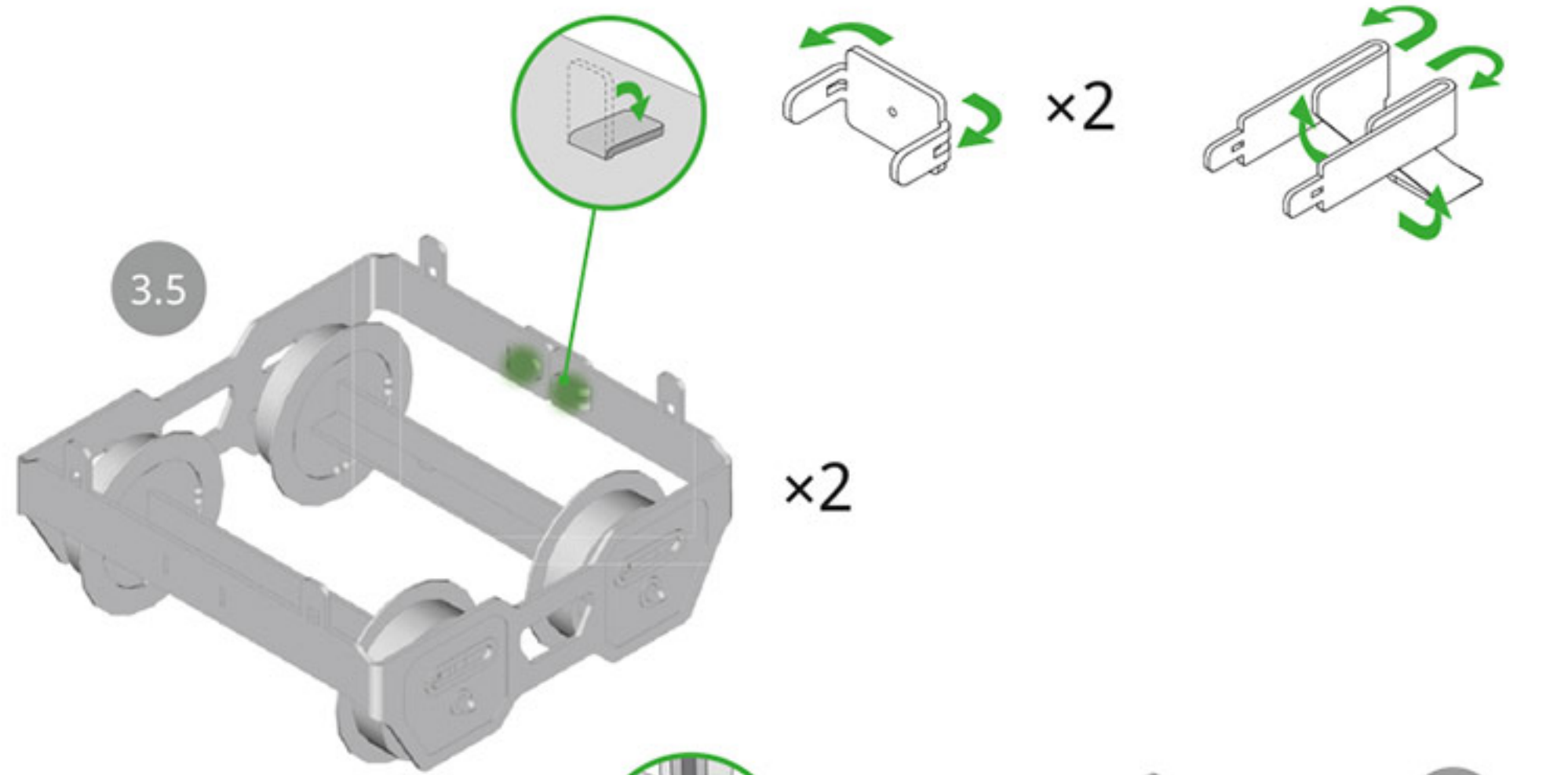

3.5

x2

x2

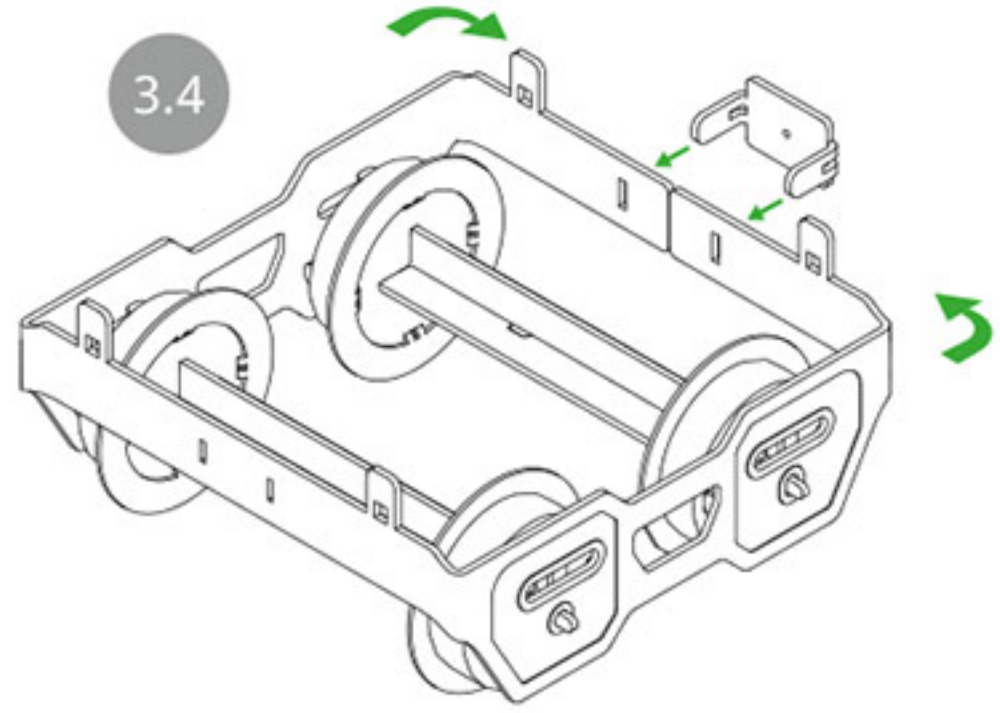

3.4

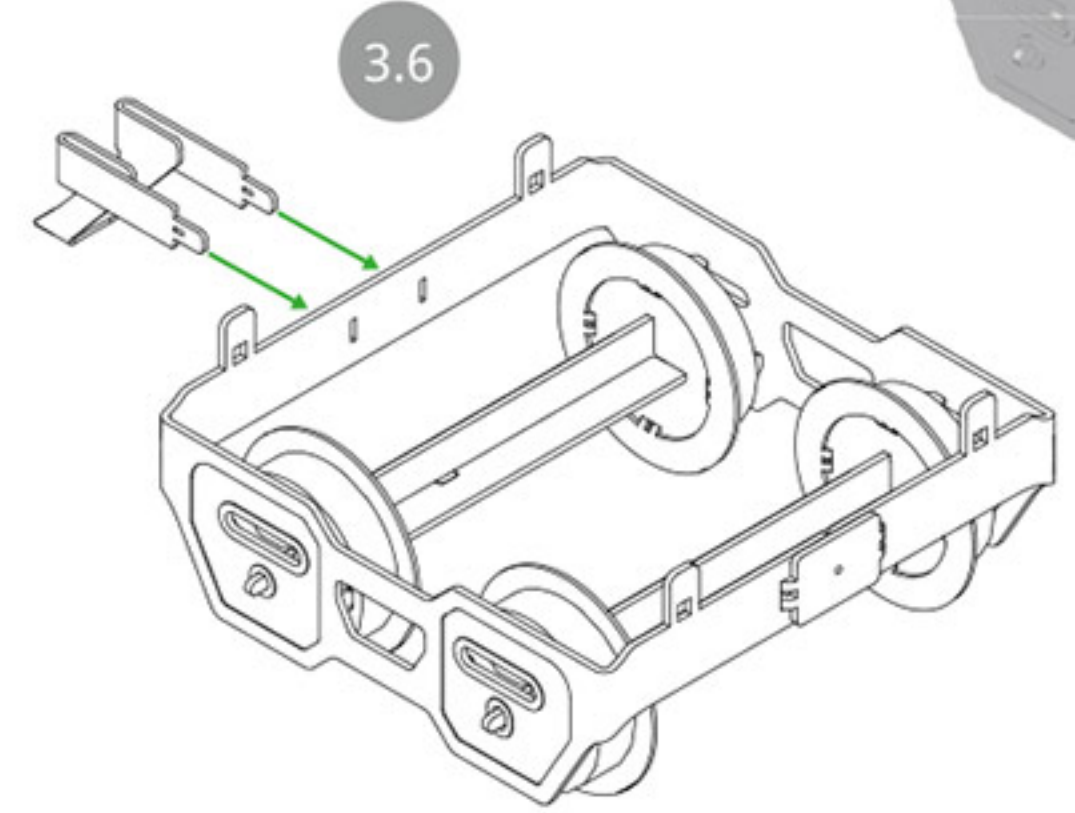

3.6

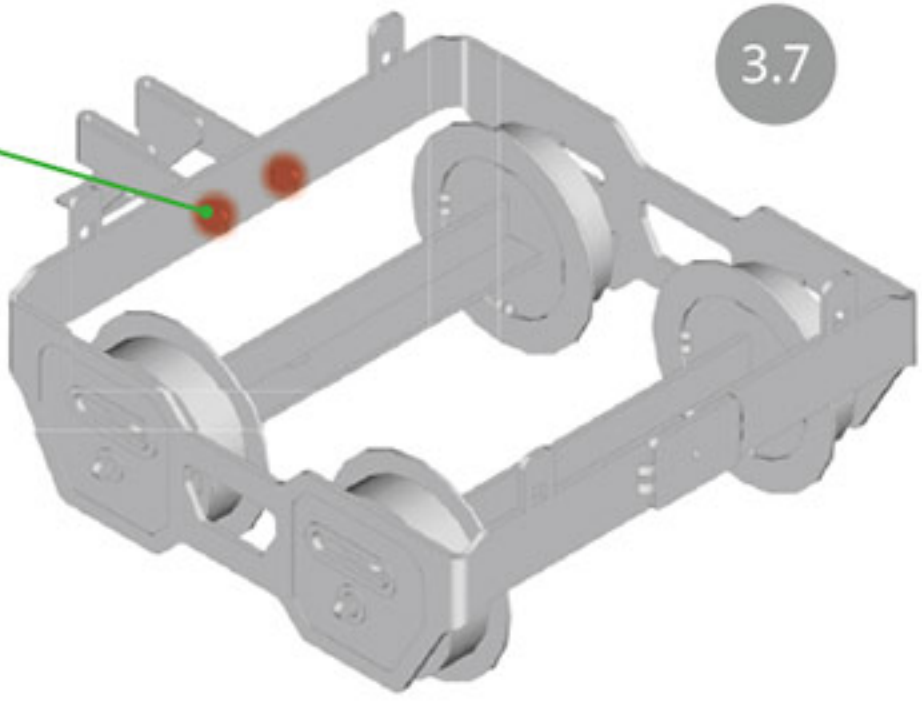

3.7

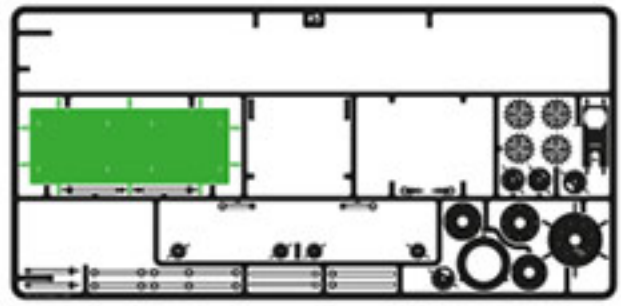

#5

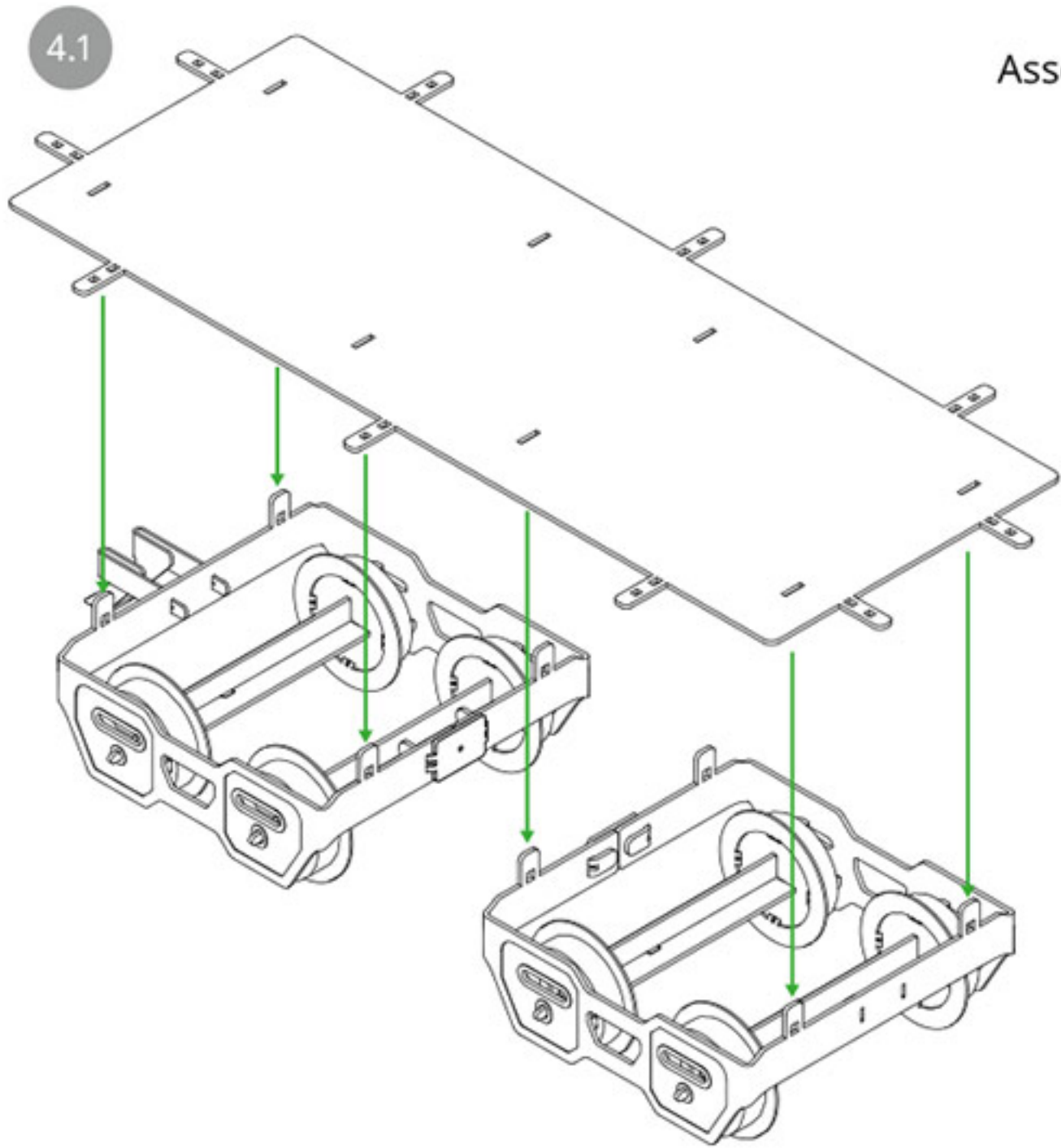

4.1

Assembly step 2

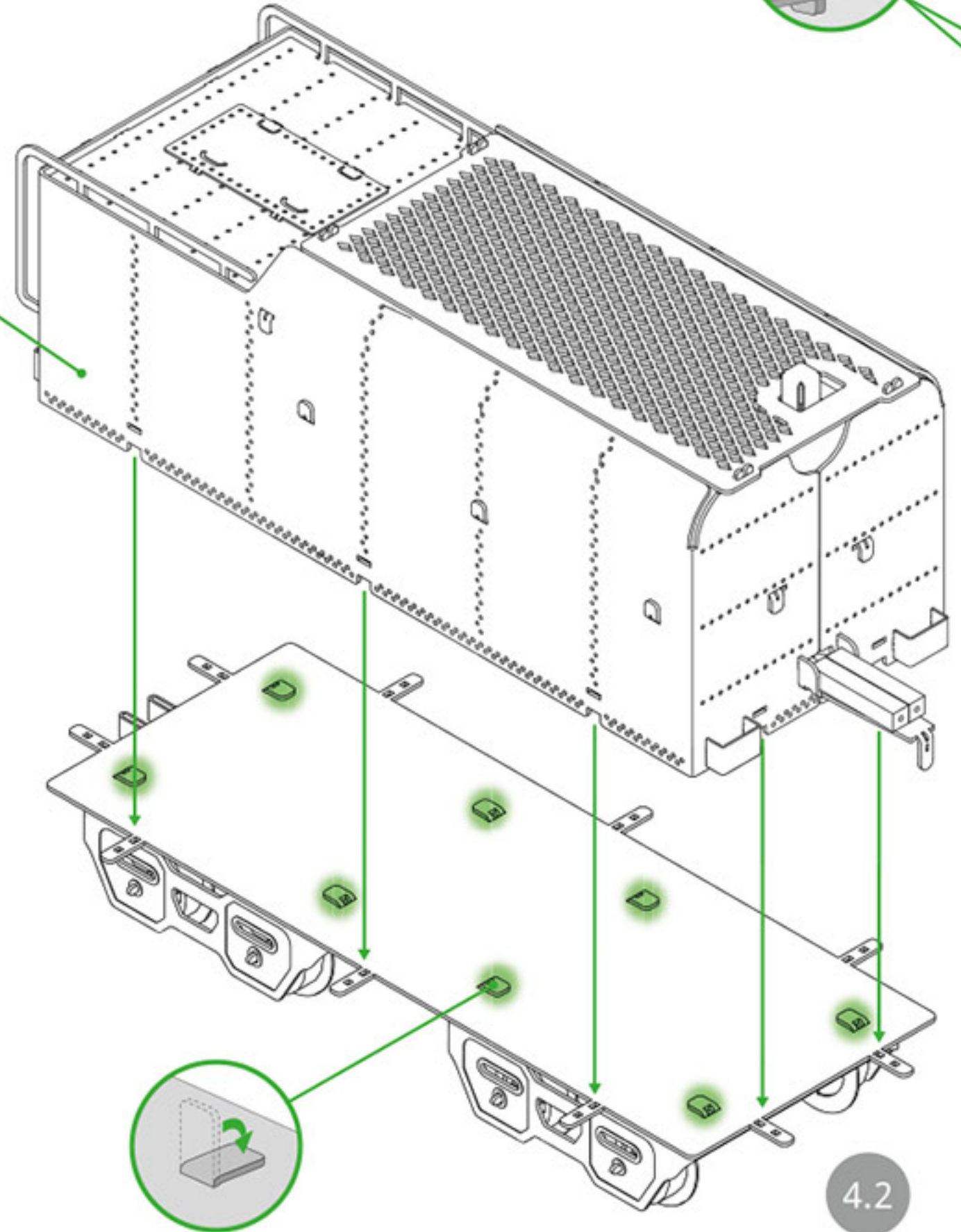

4.2

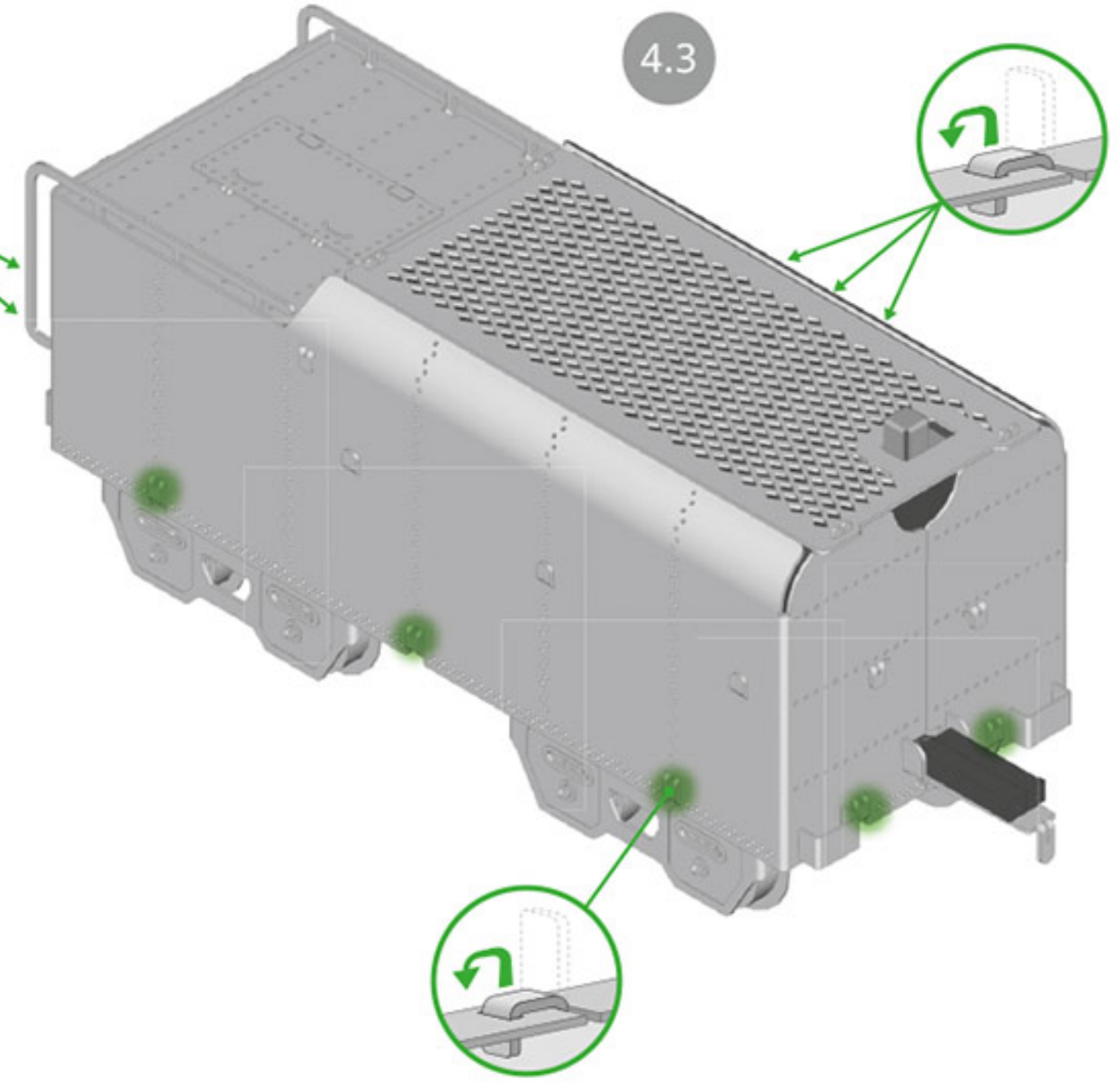

4.3

## WIRING DIAGRAM

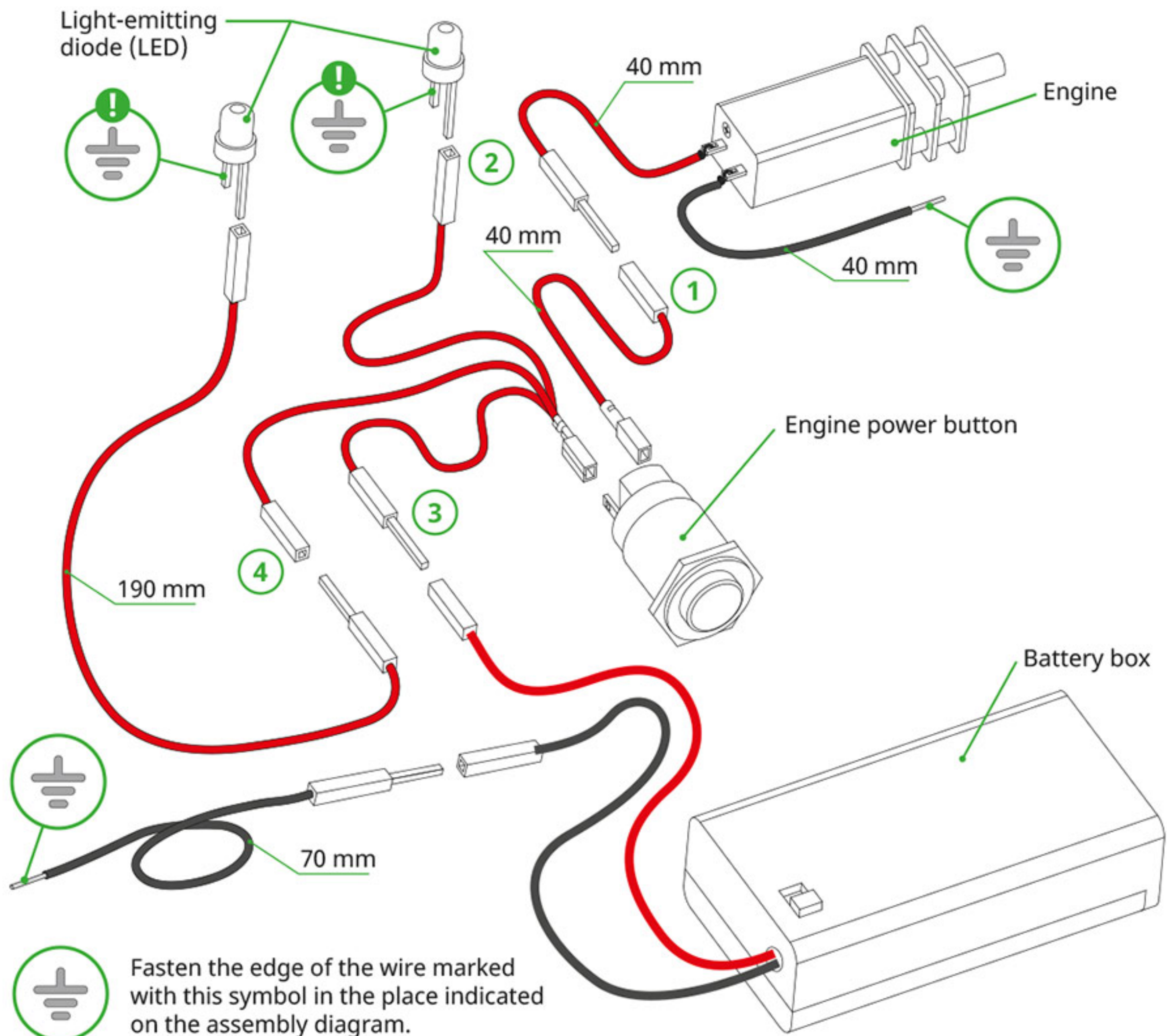

## MOTOR SHAFT ROTATION DIRECTION CHECK DIAGRAM

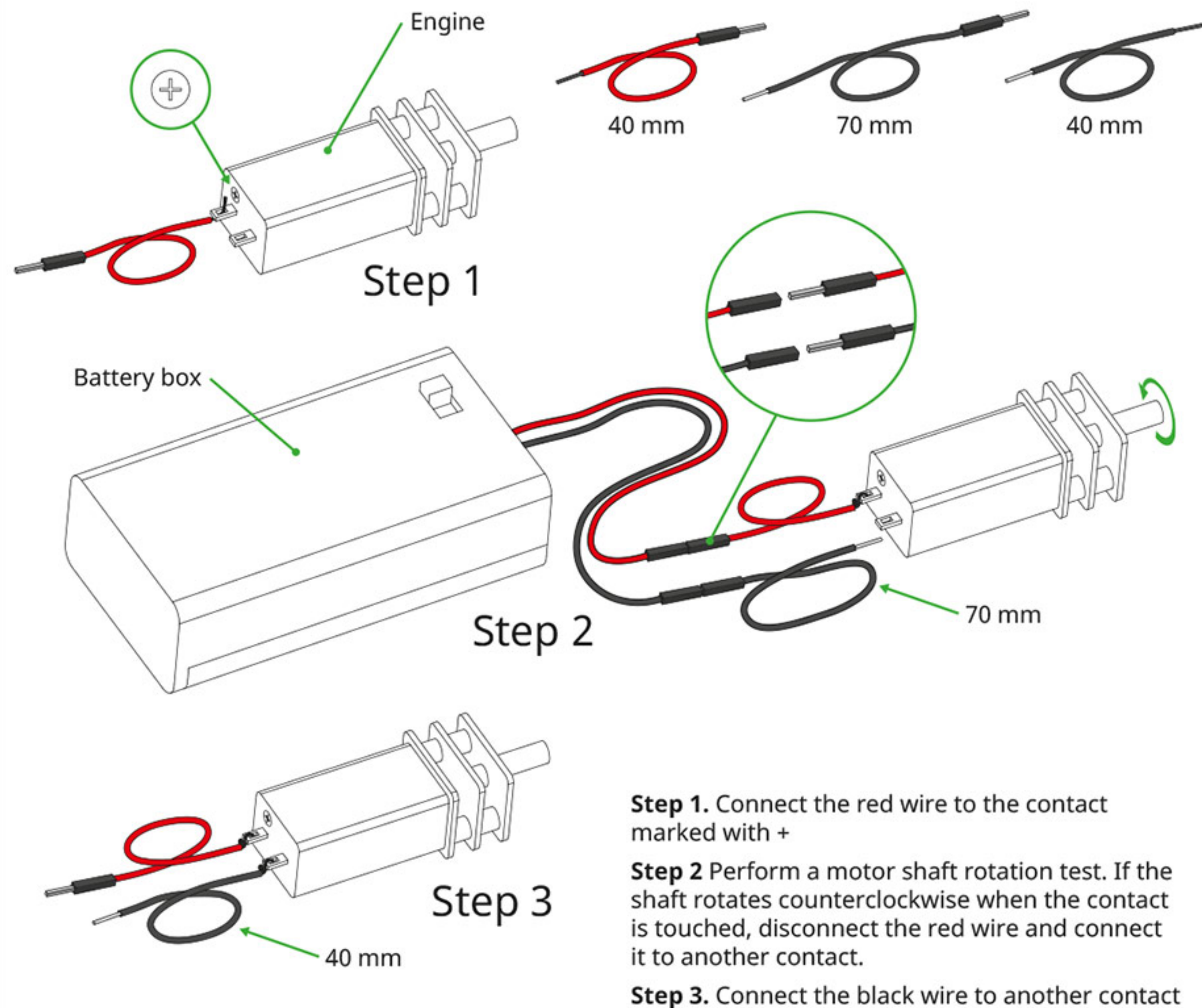

**Step 1.** Connect the red wire to the contact marked with +

**Step 2** Perform a motor shaft rotation test. If the shaft rotates counterclockwise when the contact is touched, disconnect the red wire and connect it to another contact.

**Step 3.** Connect the black wire to another contact

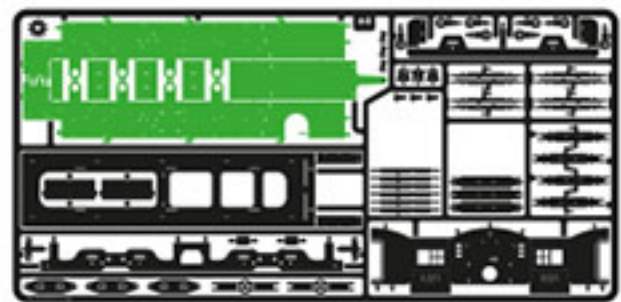

#4

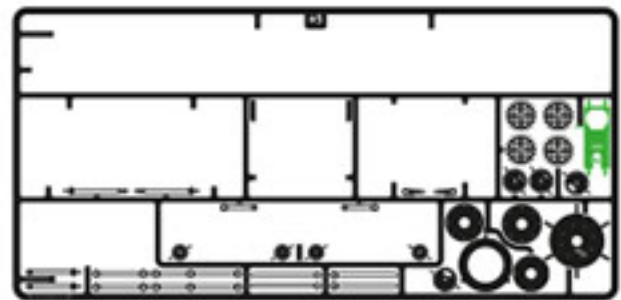

#5



At this step, use  
this method to fix  
all the ears

Engine

5.1

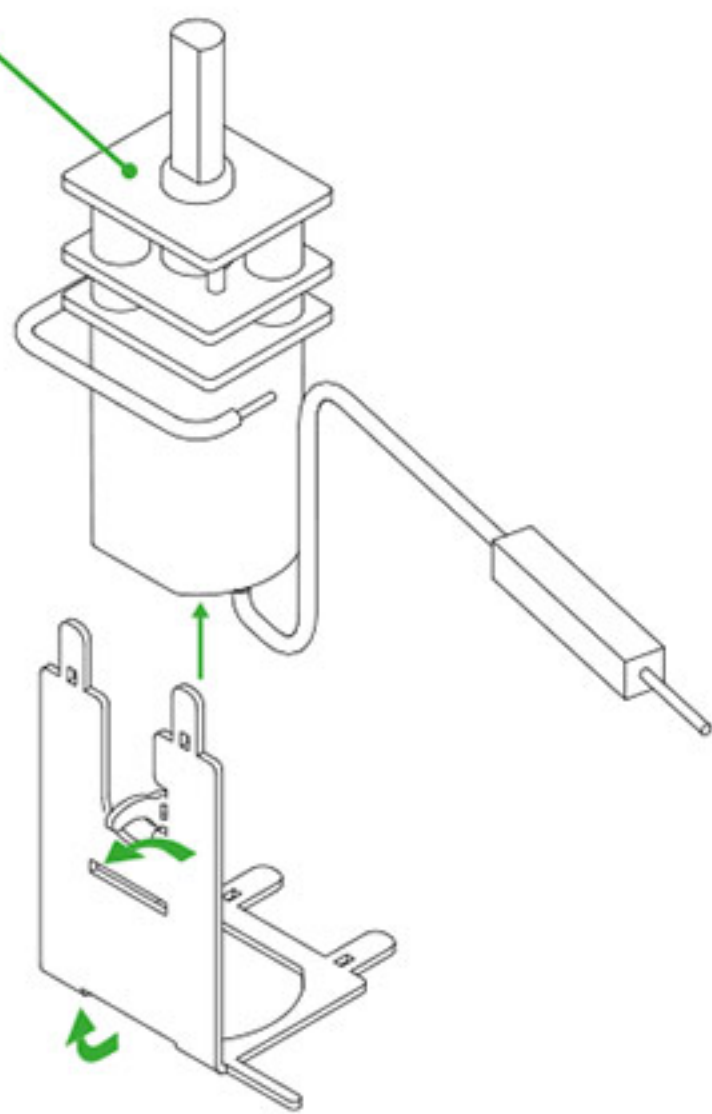

5.2

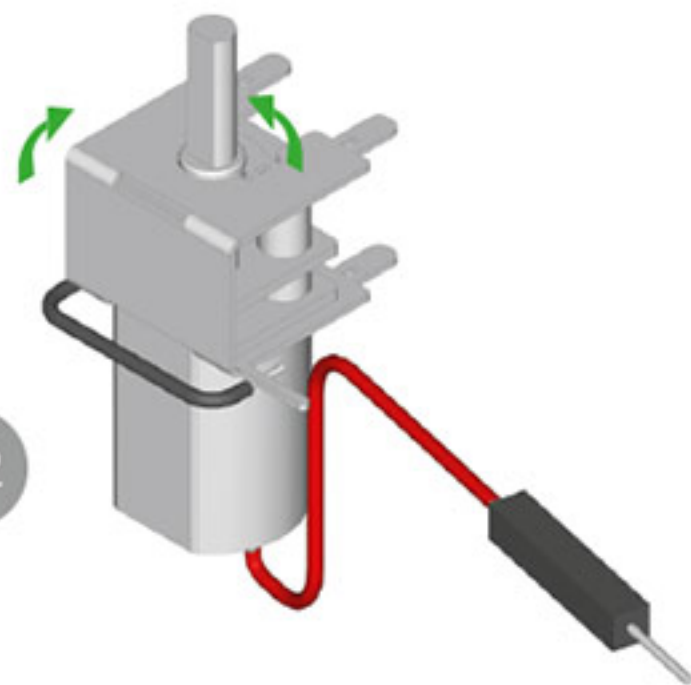

5.3

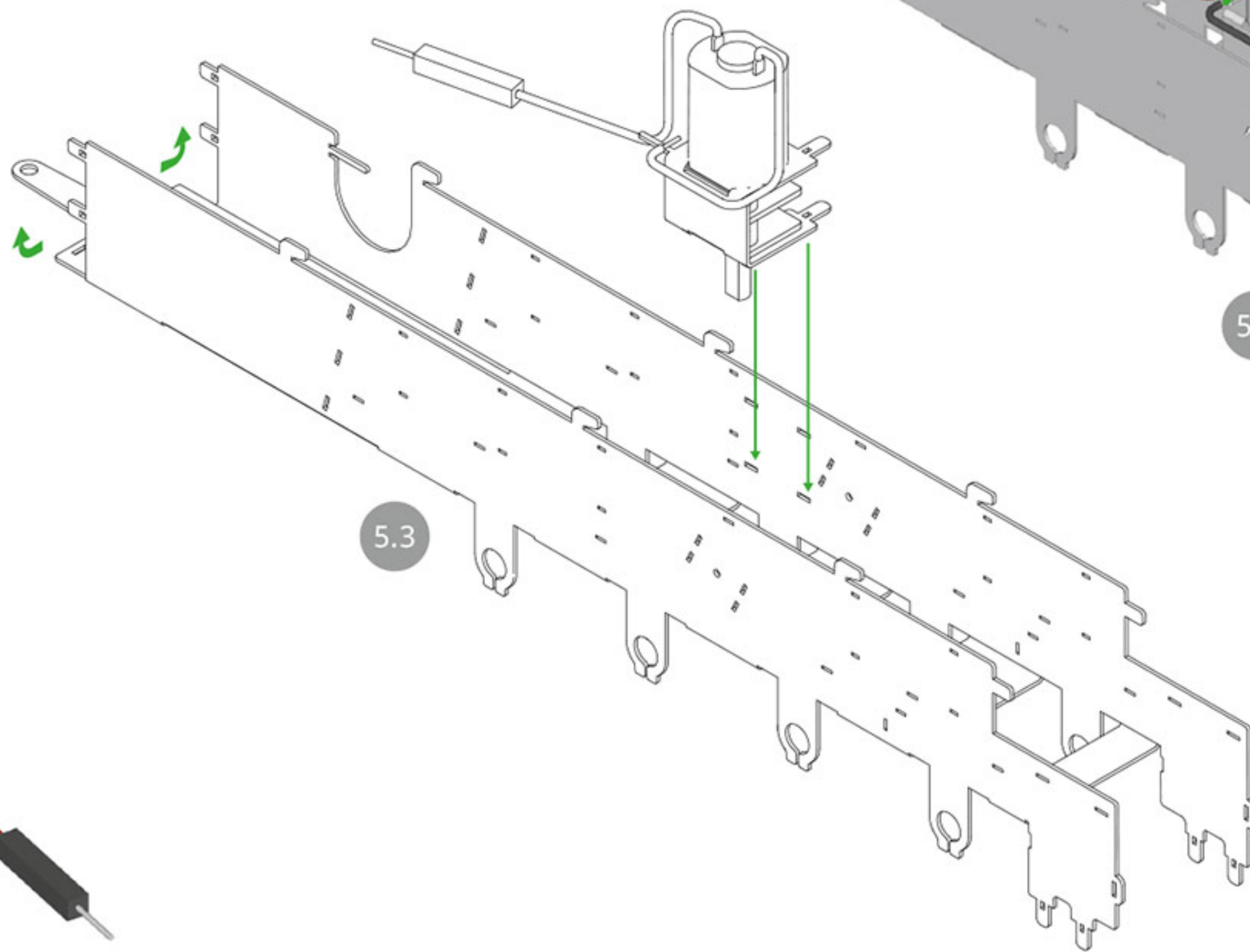

5.4

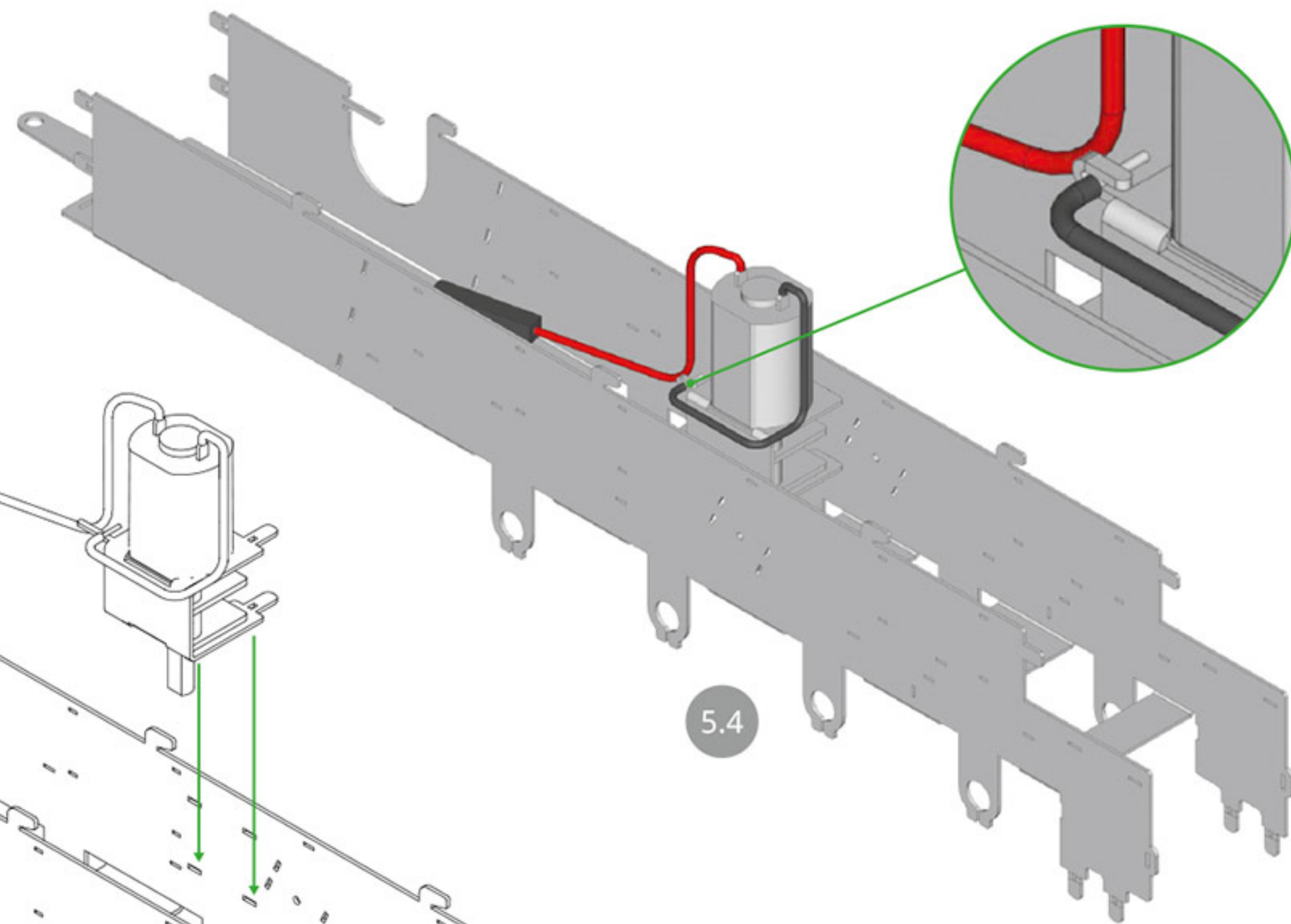



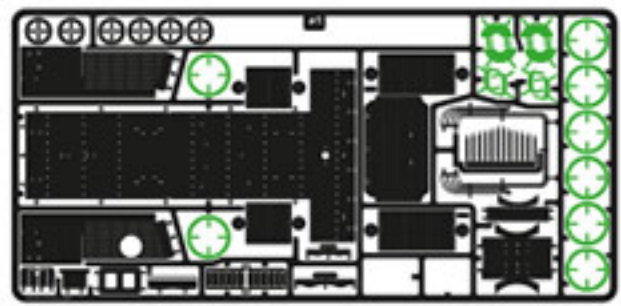

#1



#4

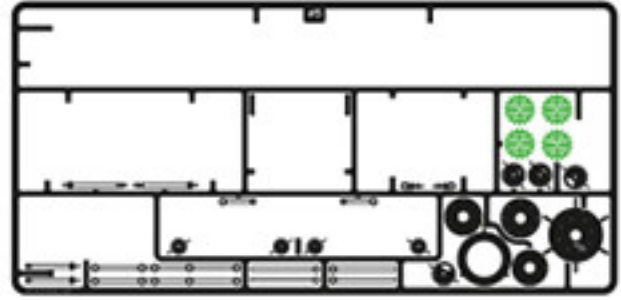

#5



x4



x4

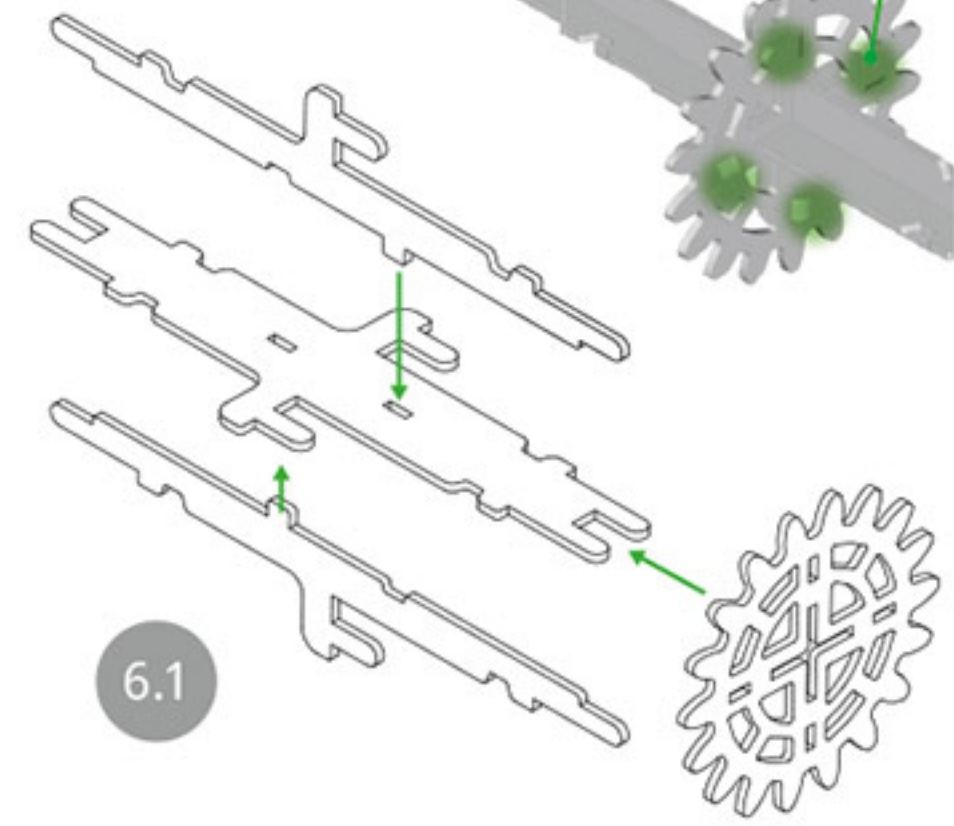

6.1

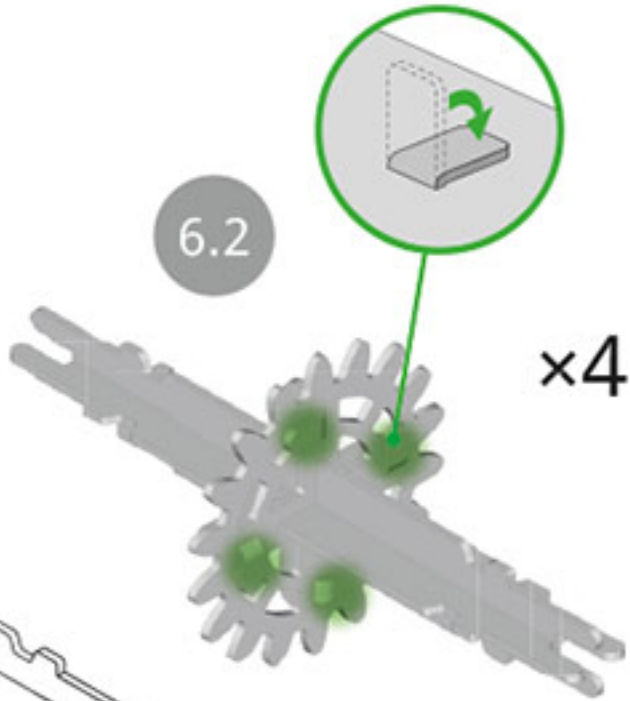

6.2

x4

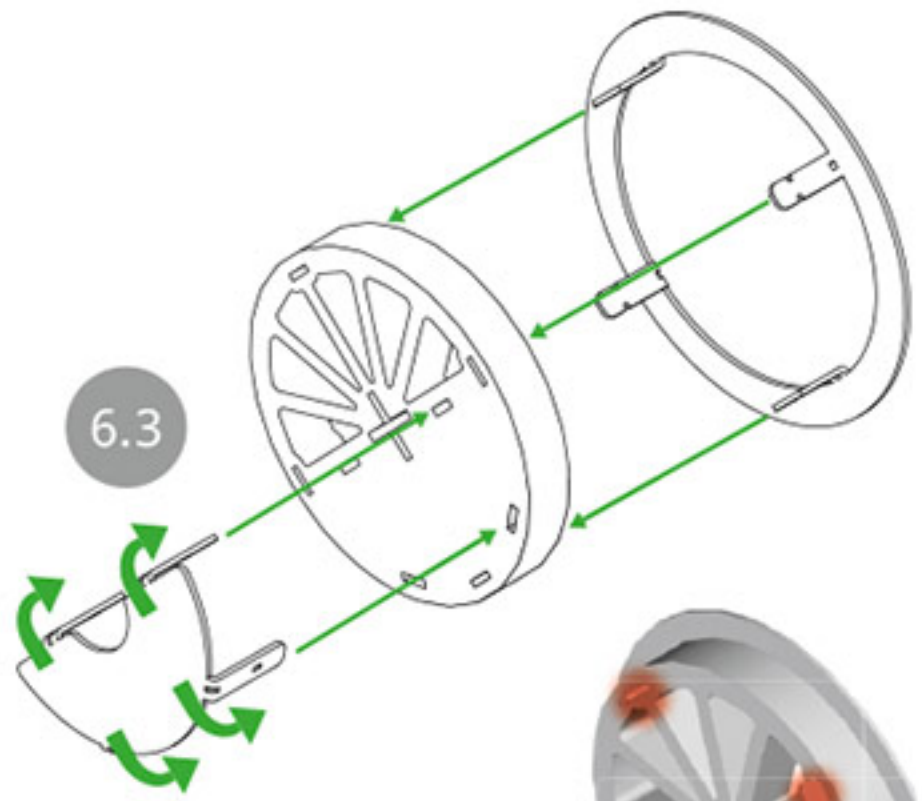

6.3

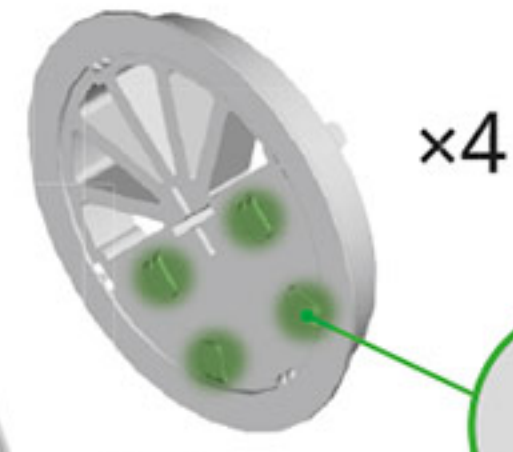

6.4

x4

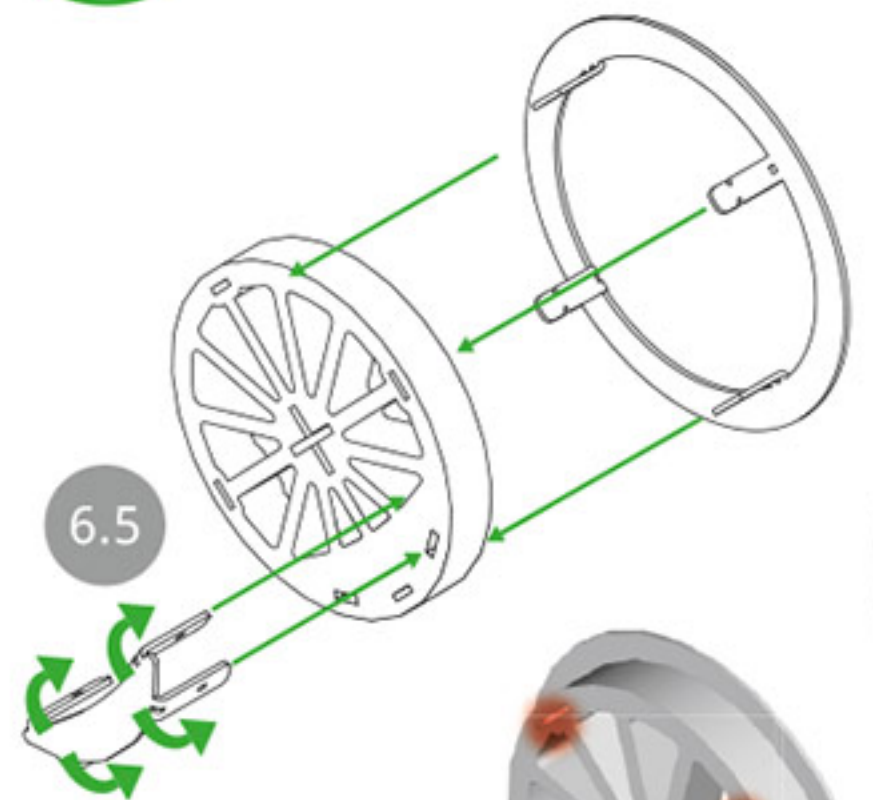
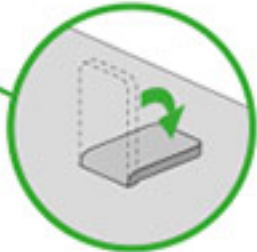

6.5

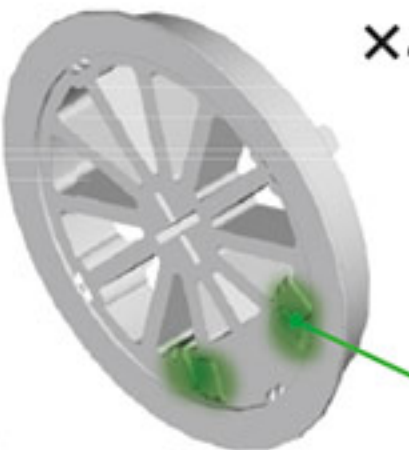

6.6

x4

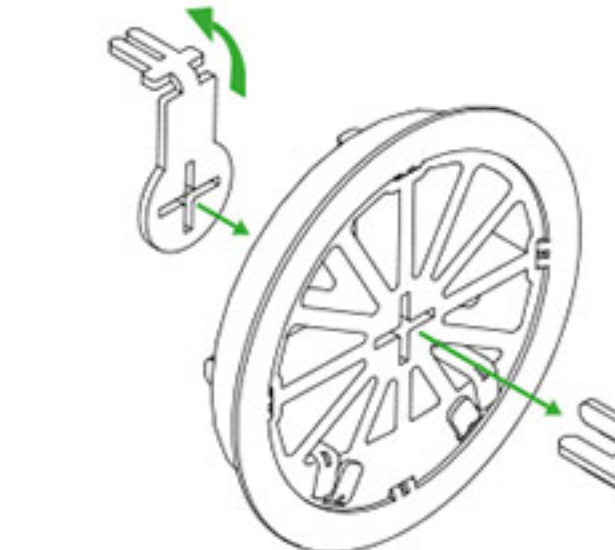

6.7

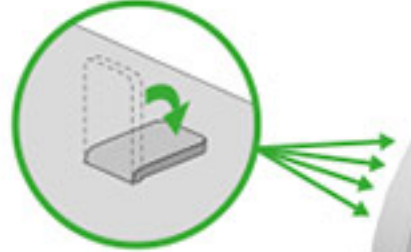

6.9

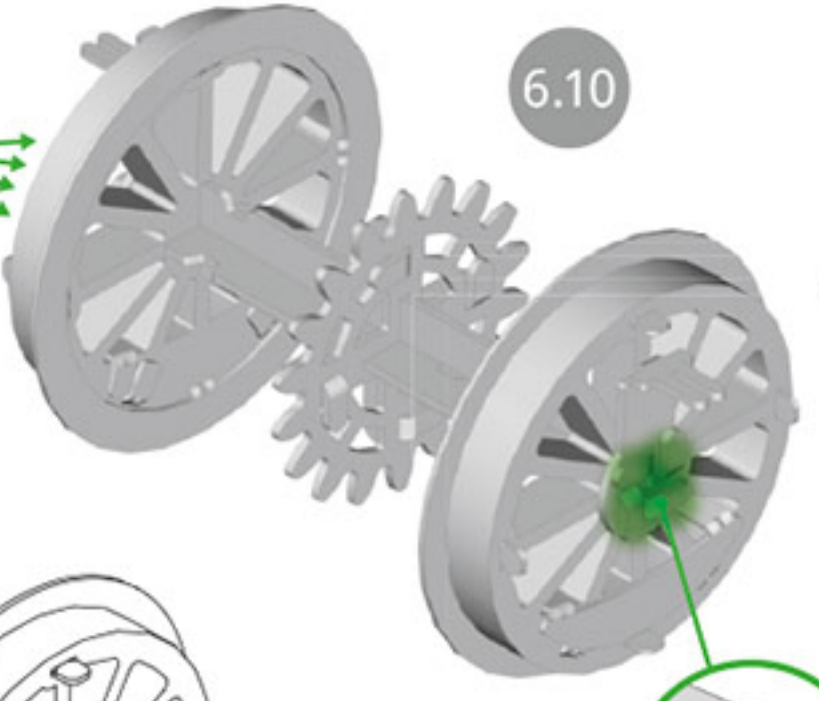
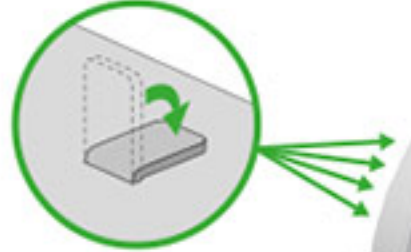

6.10

x2

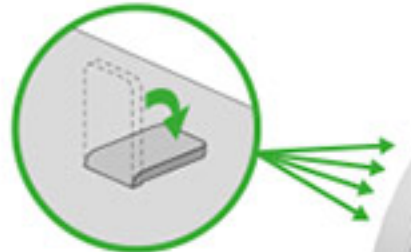

6.8

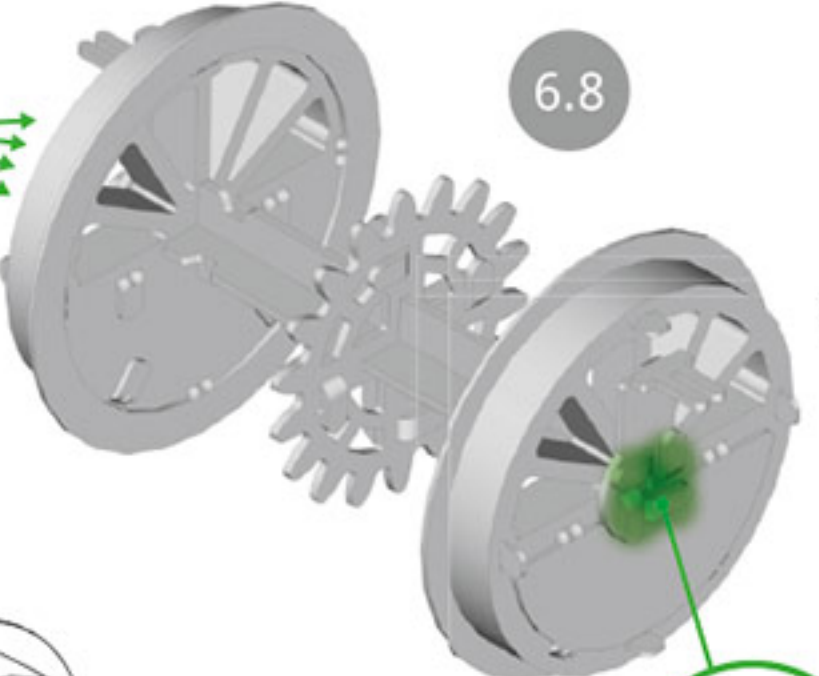

x2





#2



#4

 x3

7.3

Assembly step 6.8

Assembly step 6.10

7.4

7.5

7.6

7.7

x3

7.8



7.1

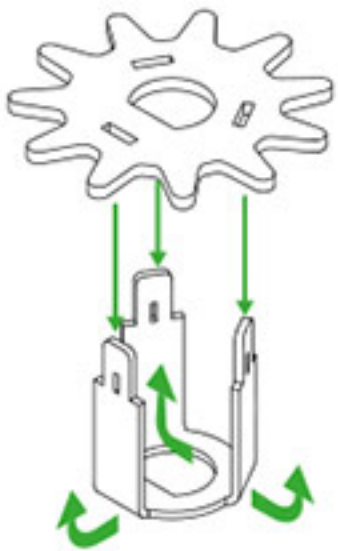

7.2

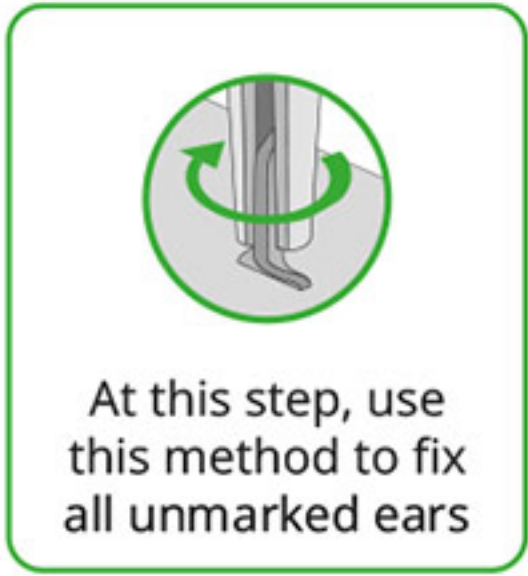
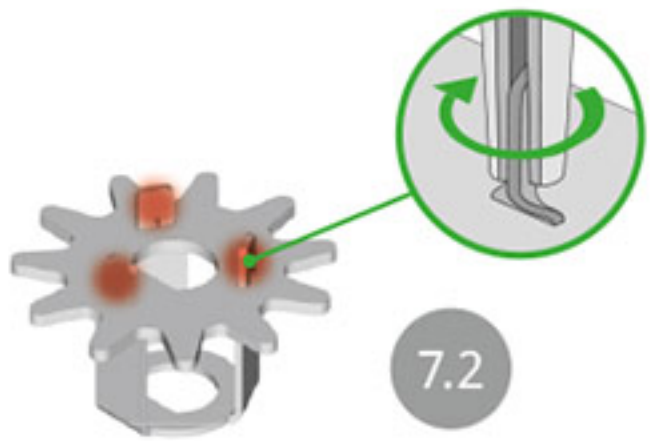

At this step, use this method to fix all unmarked ears

7.9

7.10



#1



#4

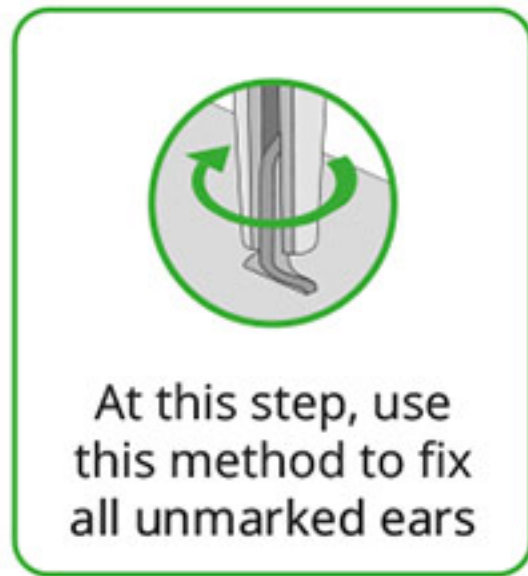

x6

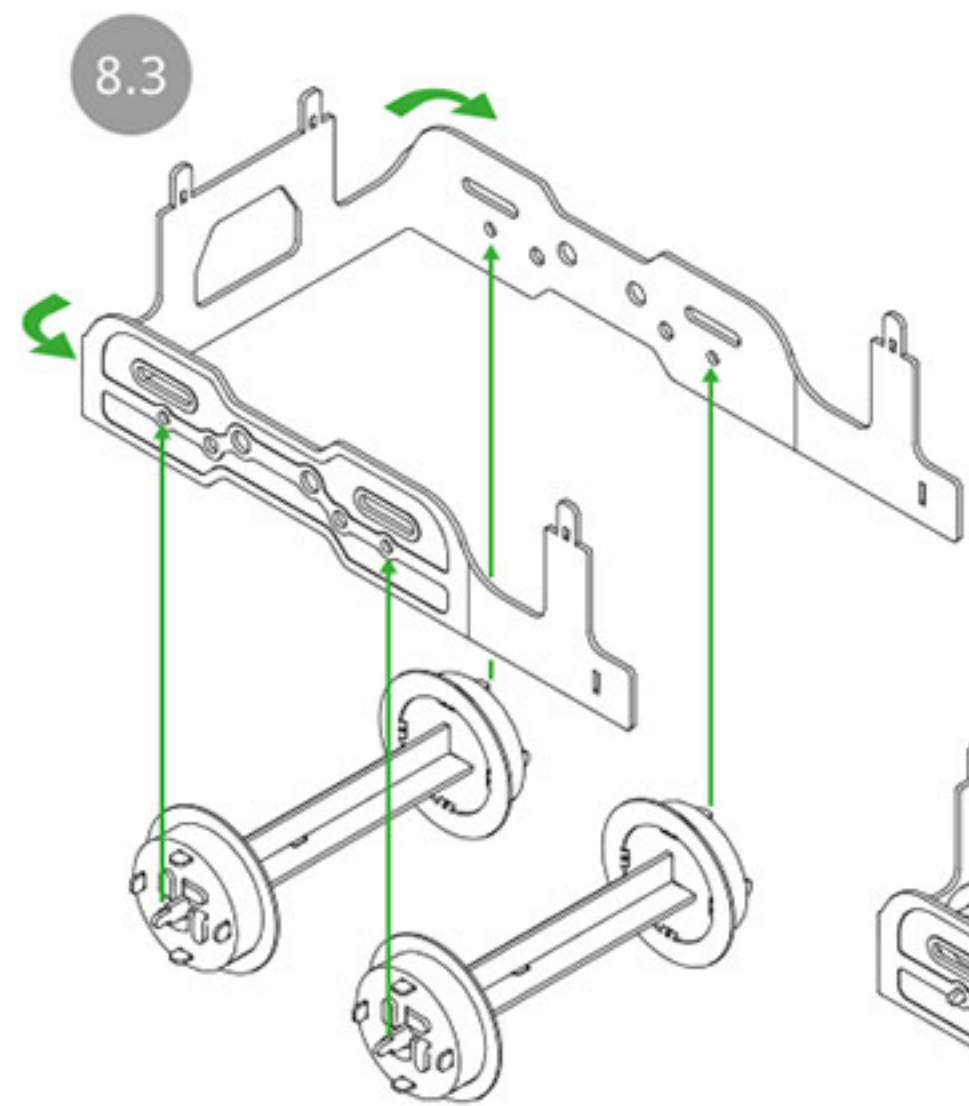

8.3

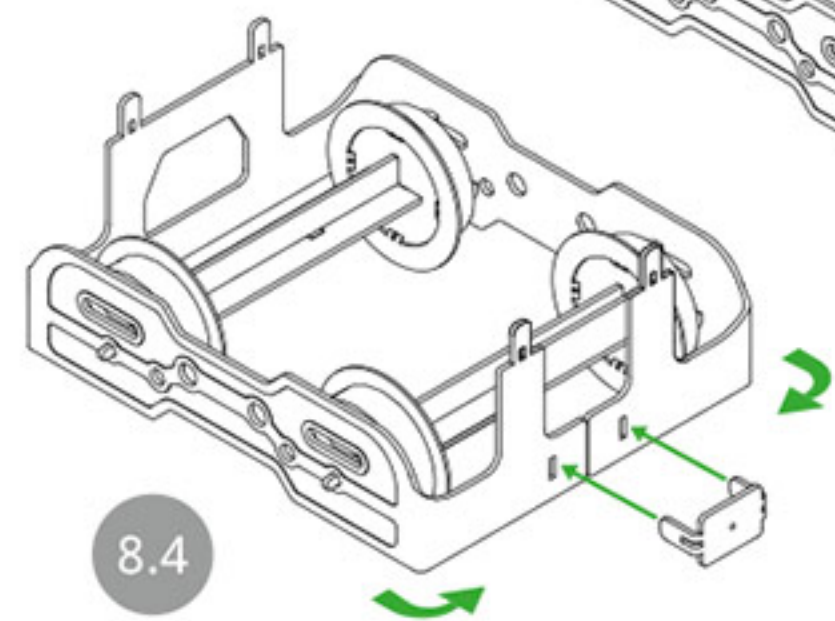

8.4

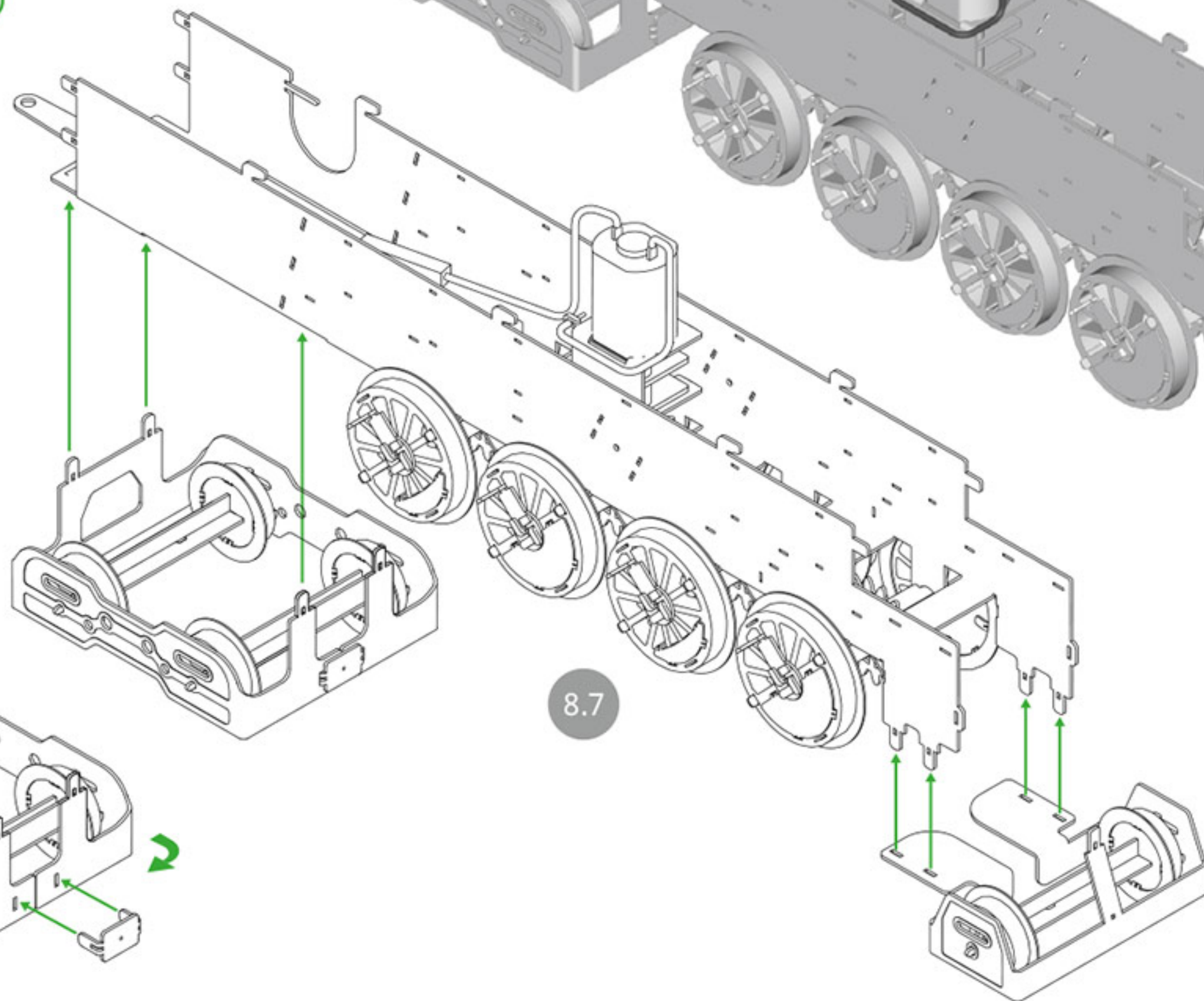

8.7

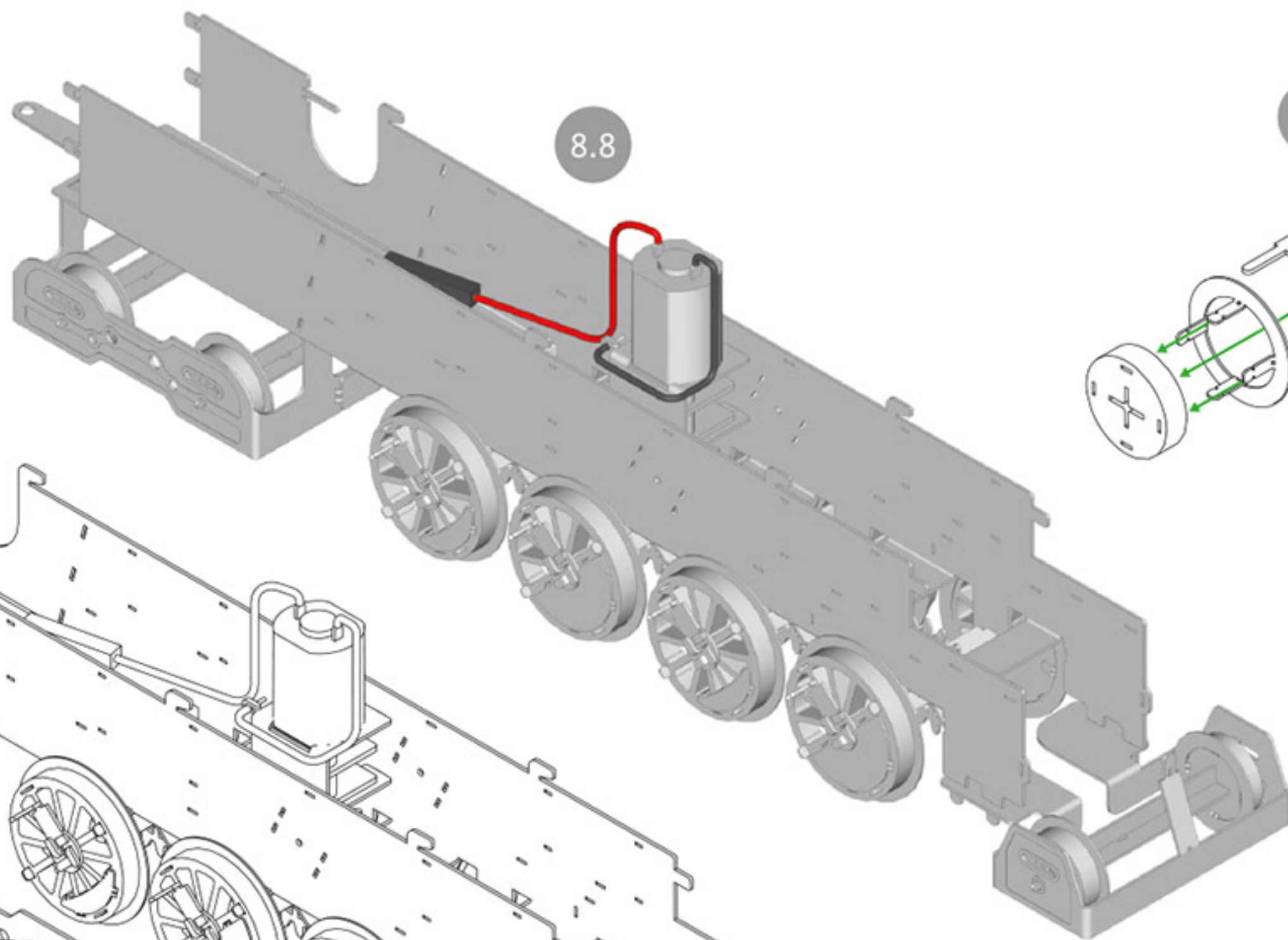

8.8

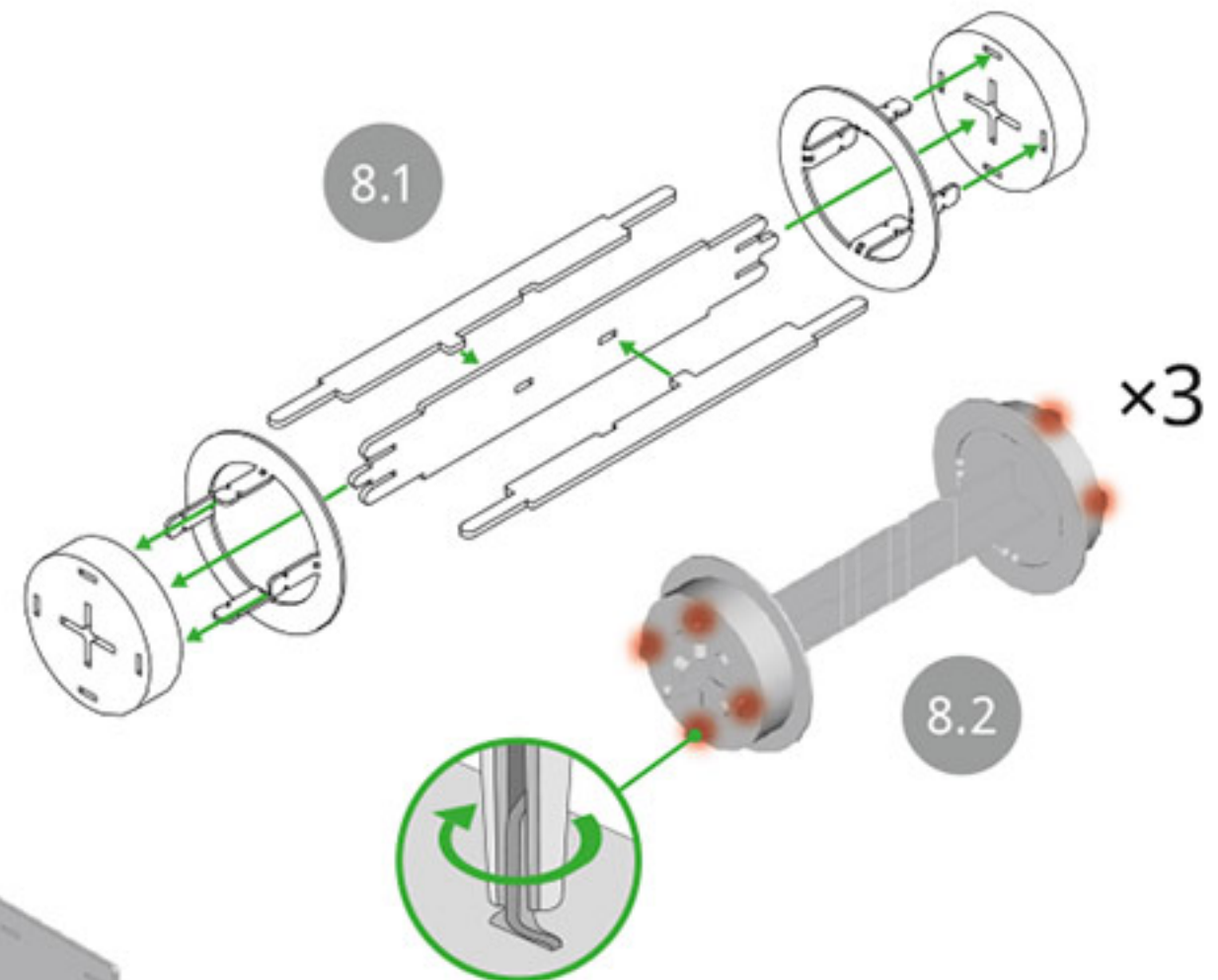

8.1



8.2

x3

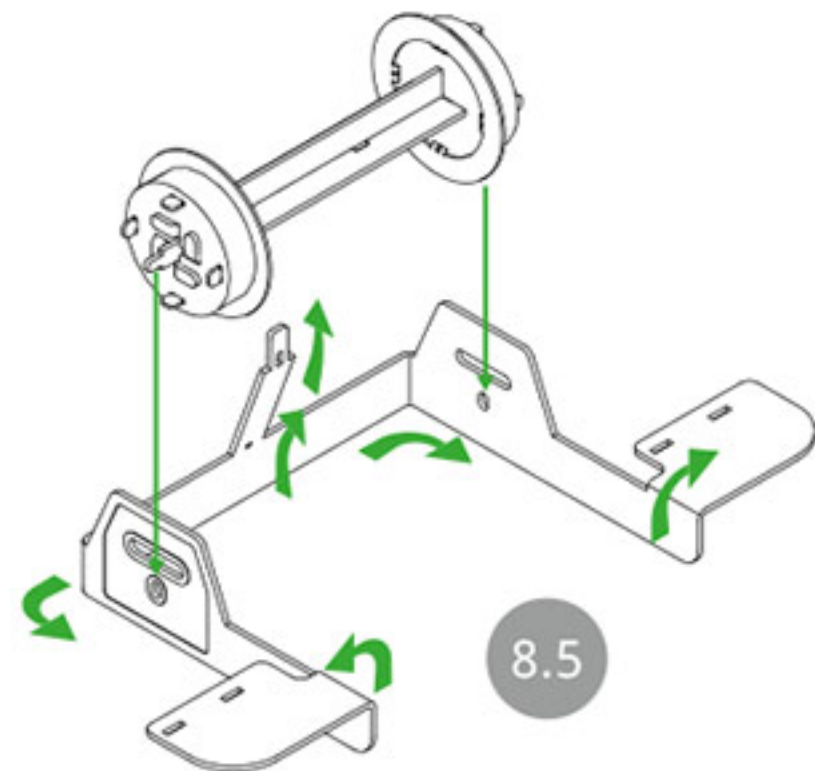

8.5

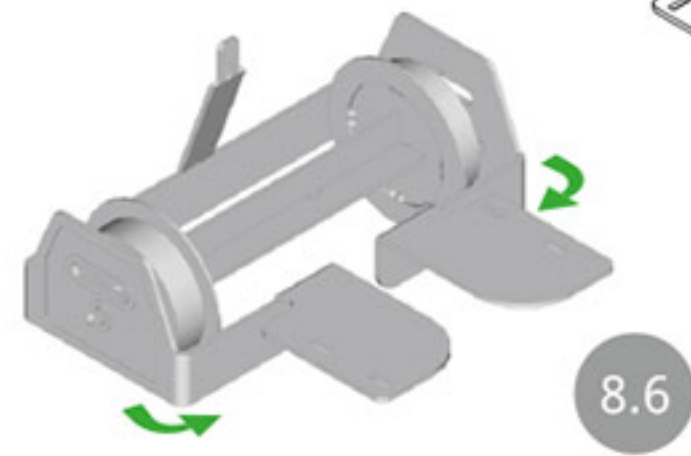

8.6

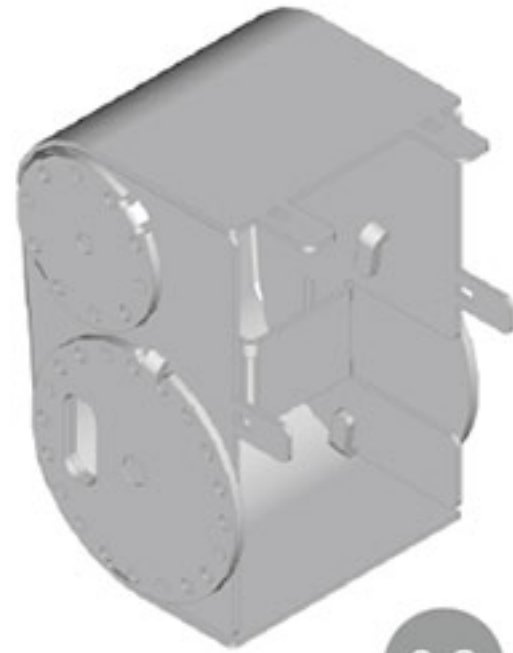
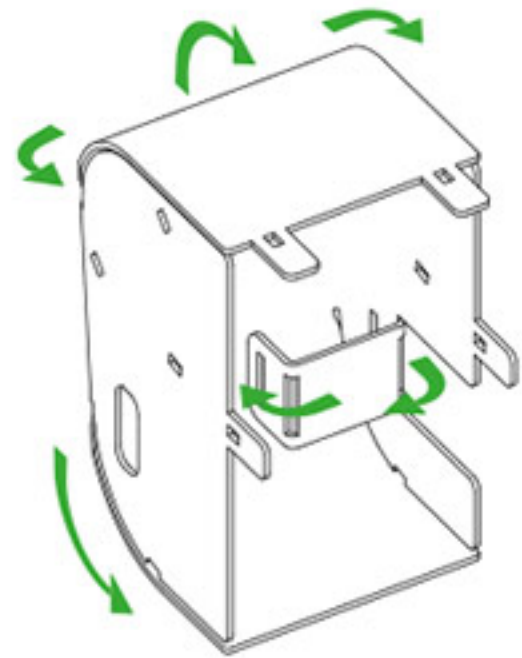
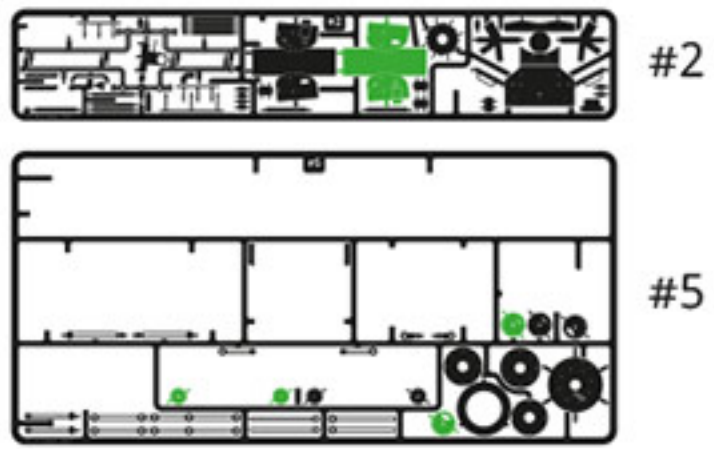

9.3

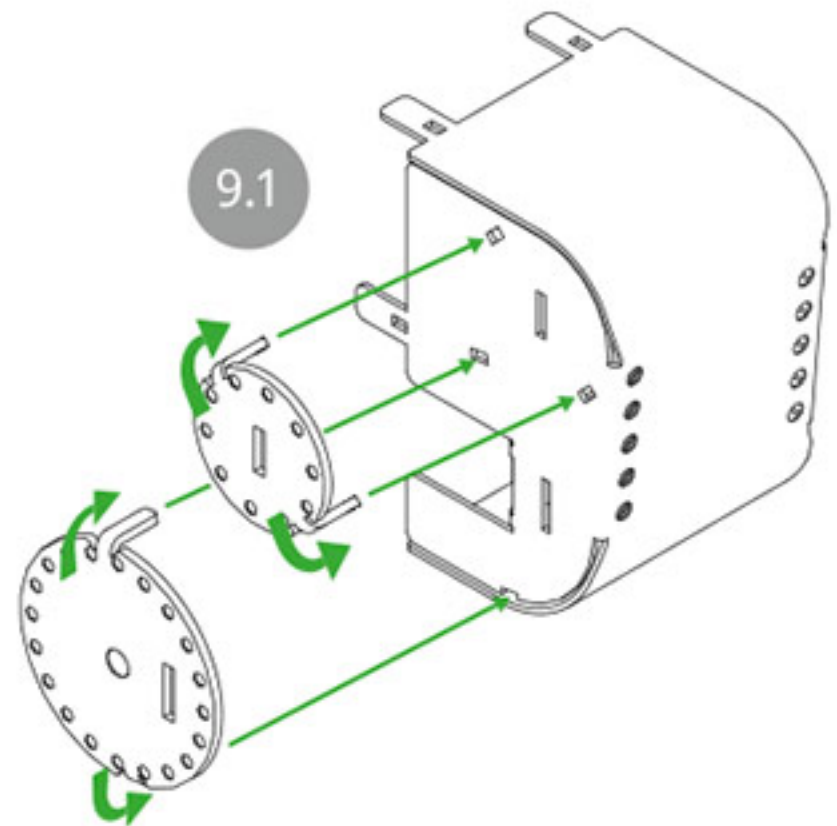

9.1

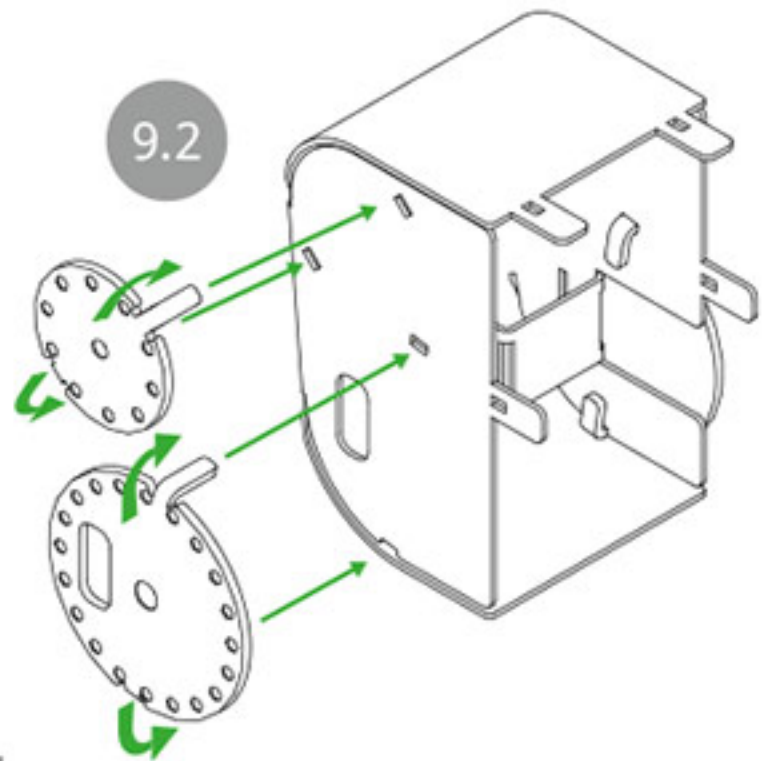

9.2

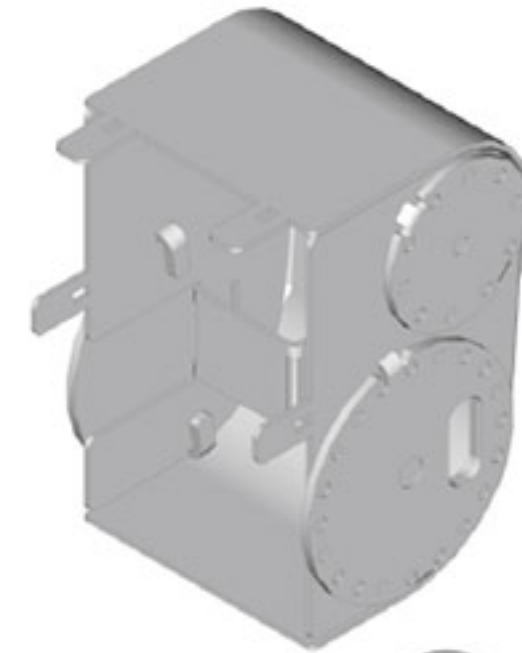
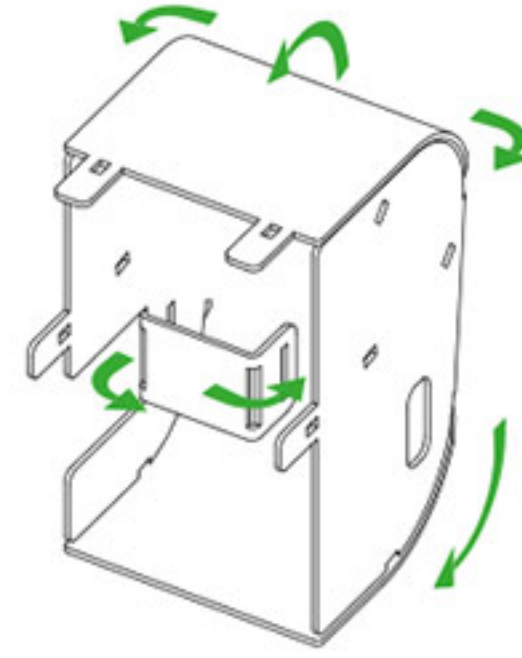
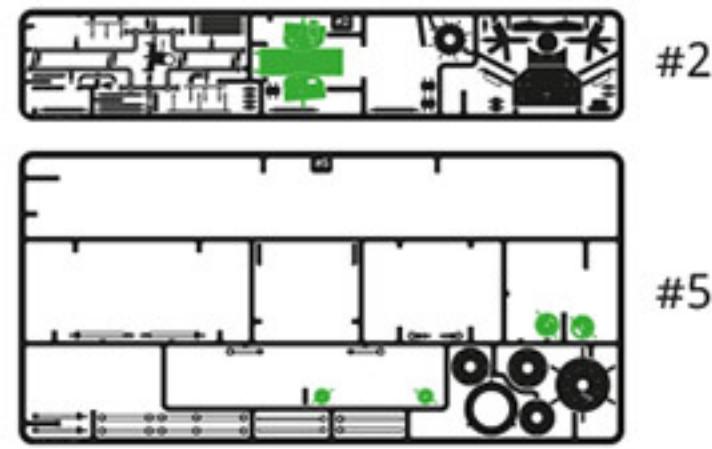
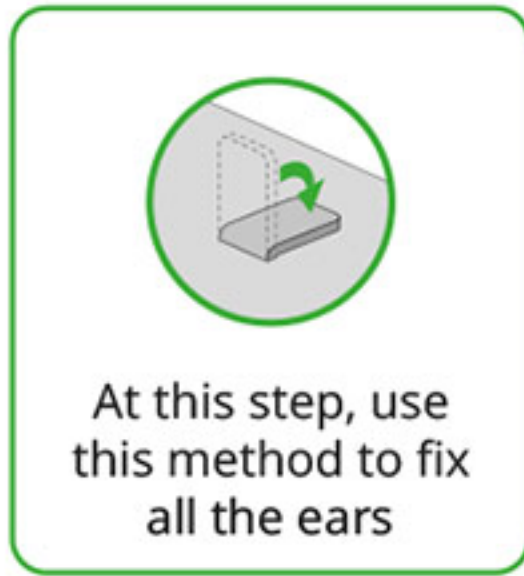

10.3

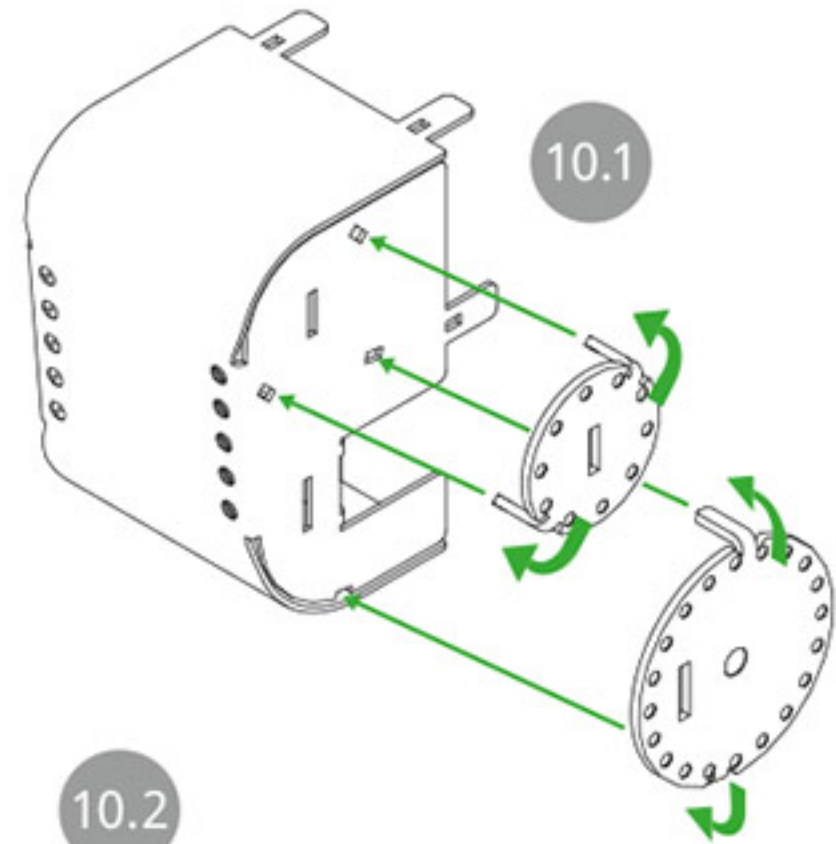

10.1

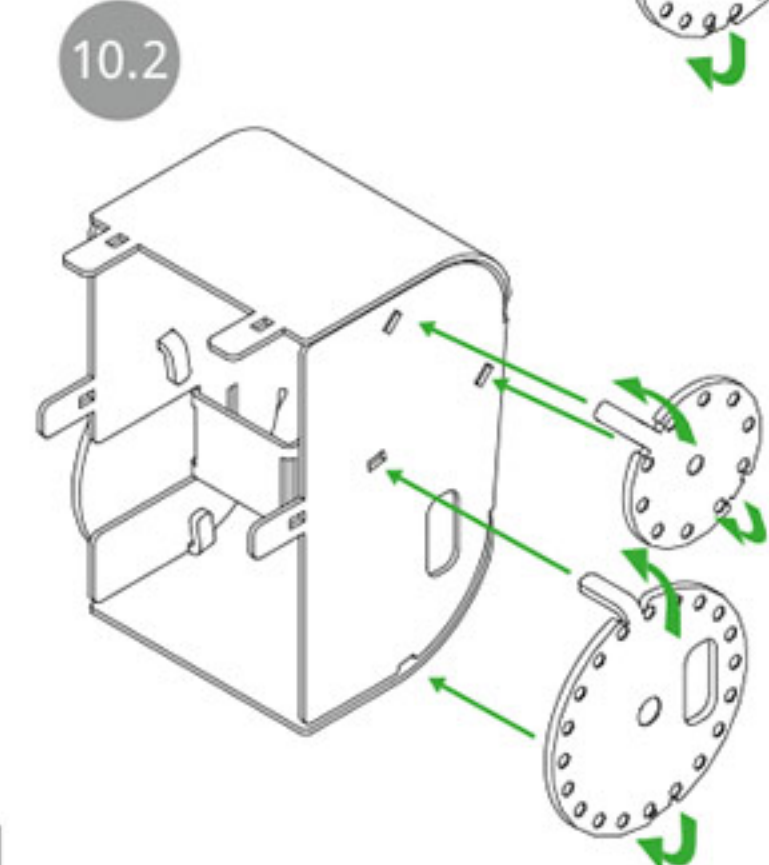

10.2

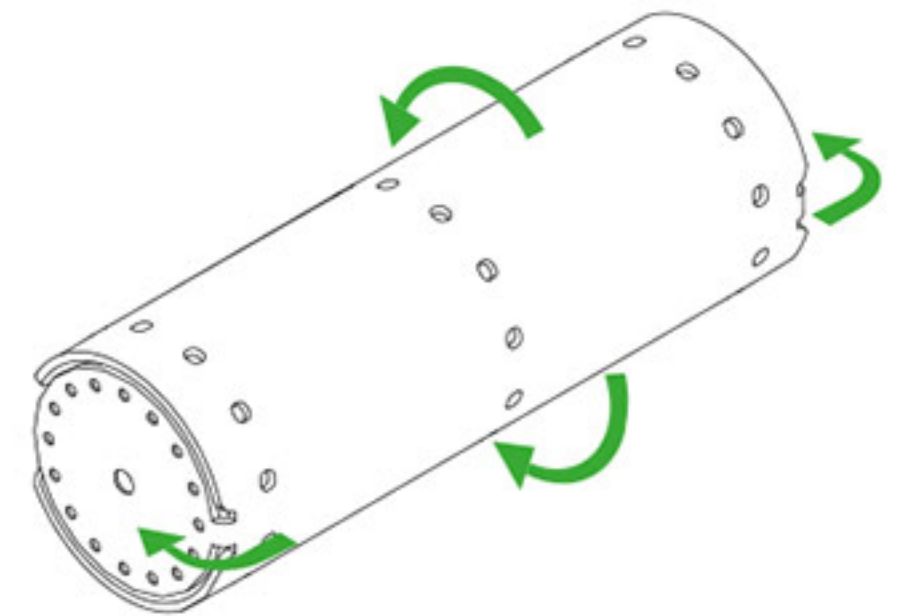
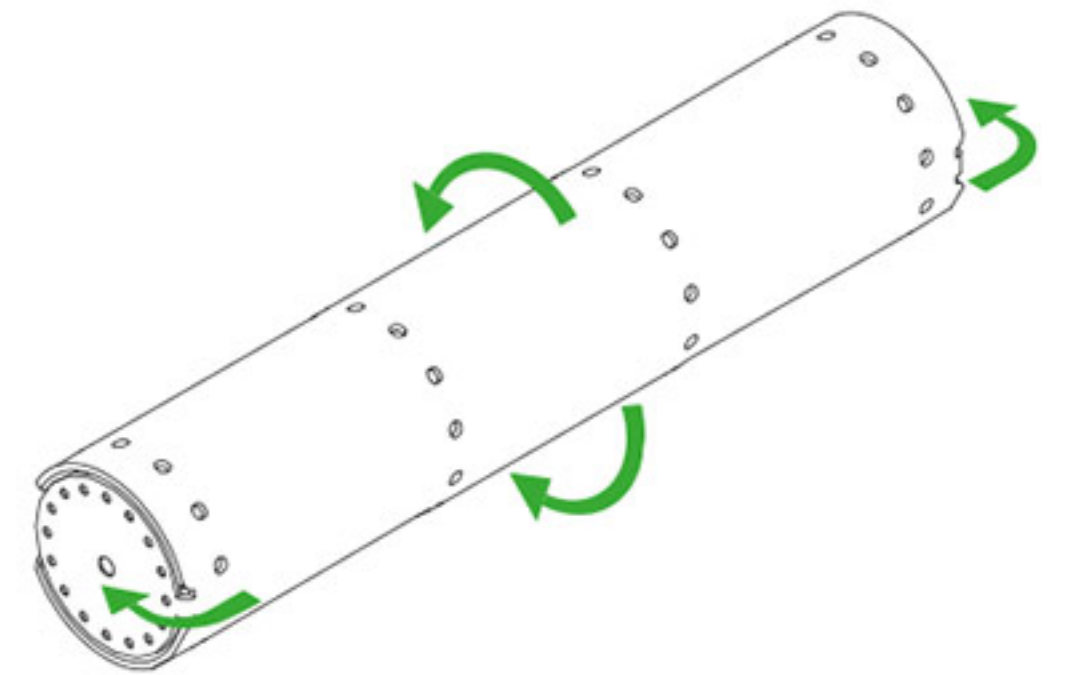
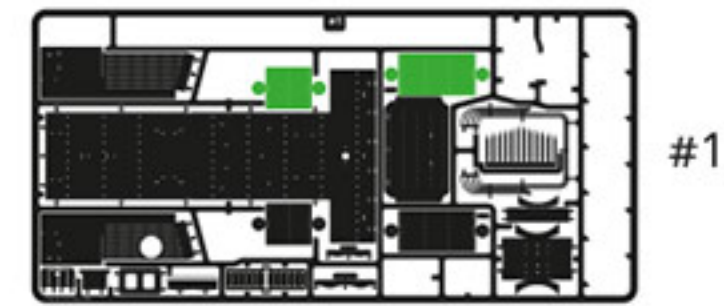
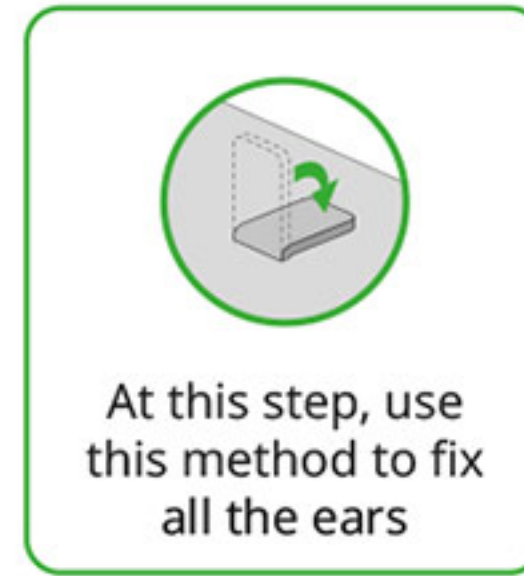

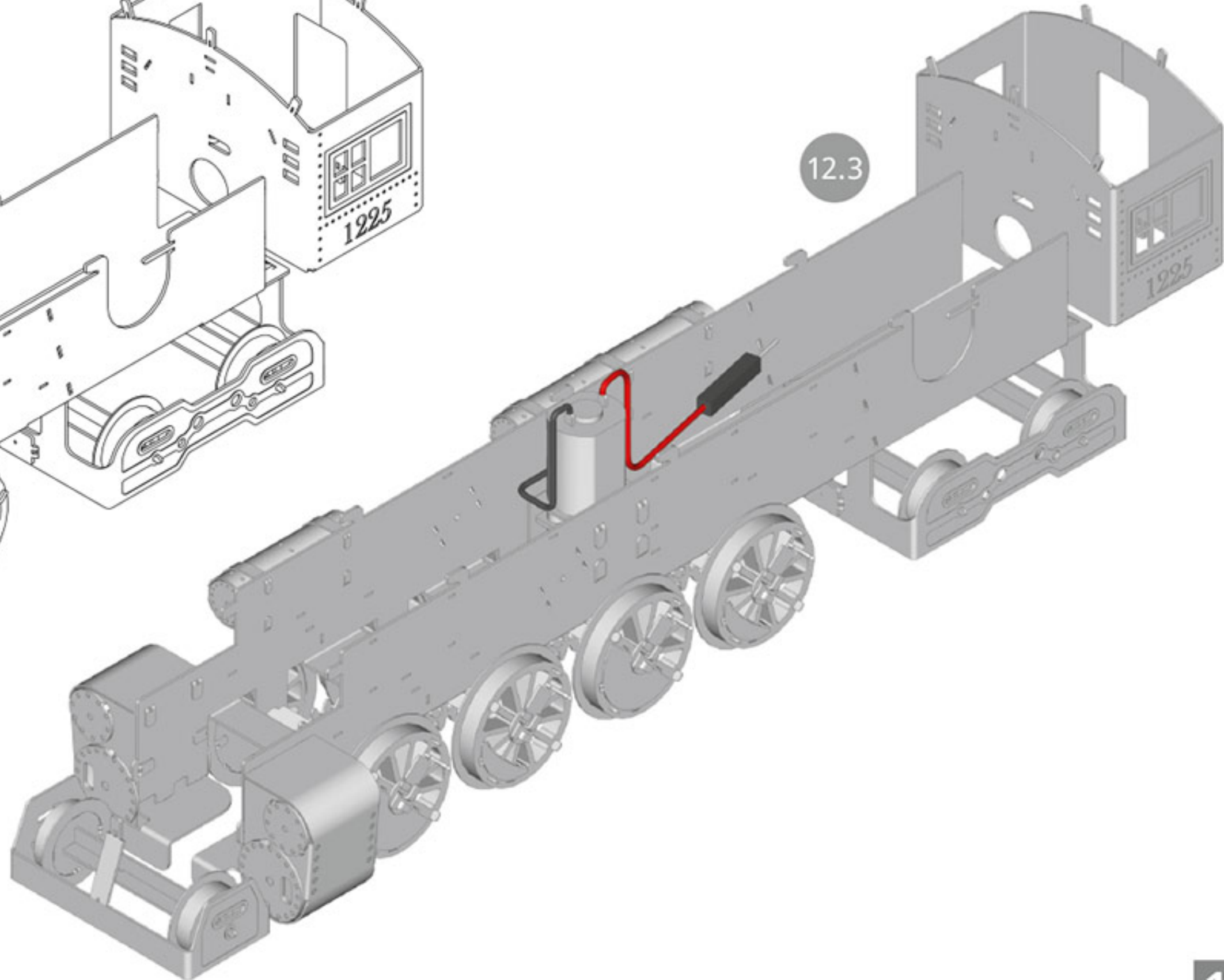
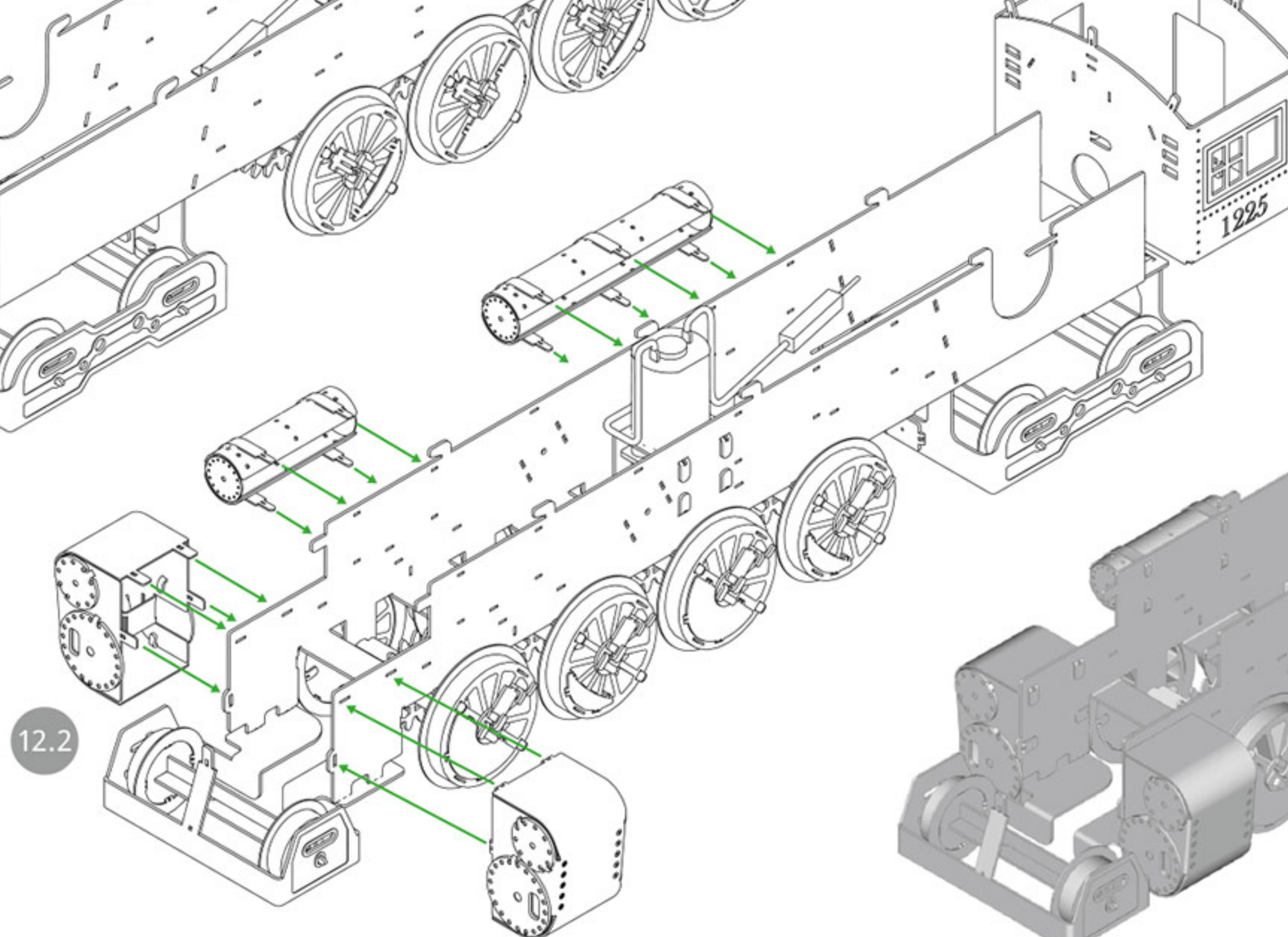
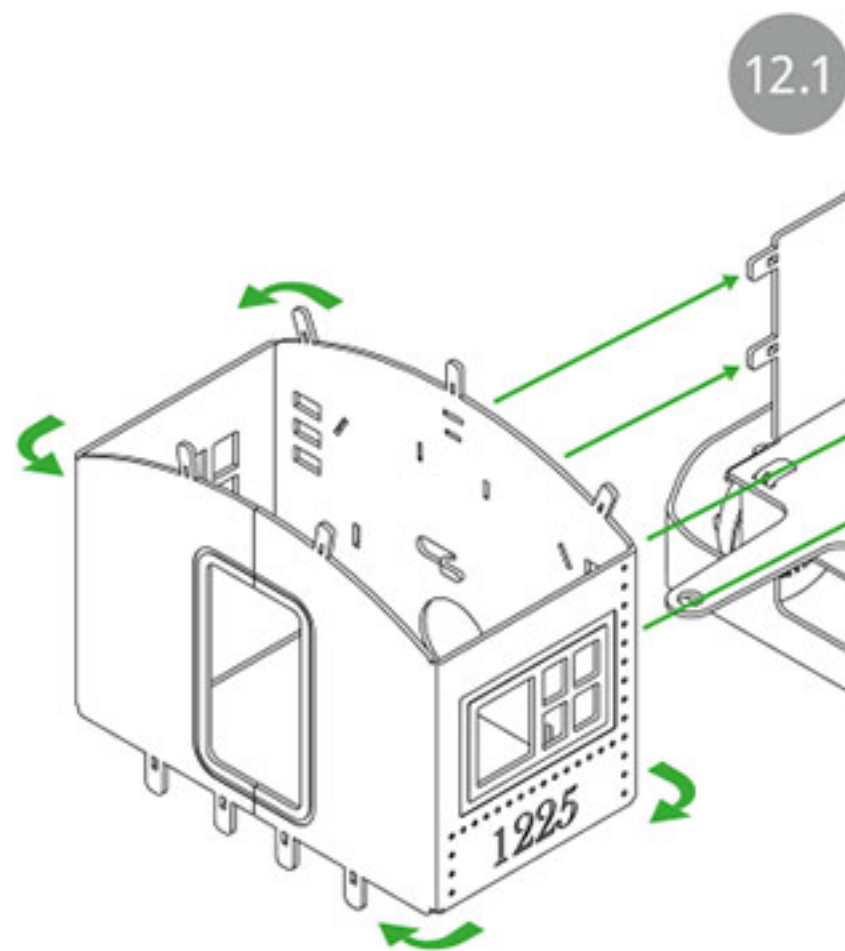
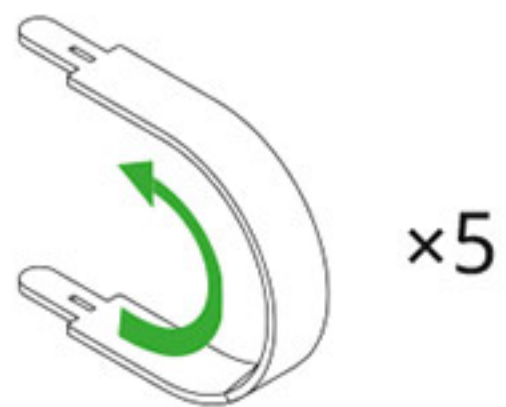

At this step, use this method to fix all the ears



#5

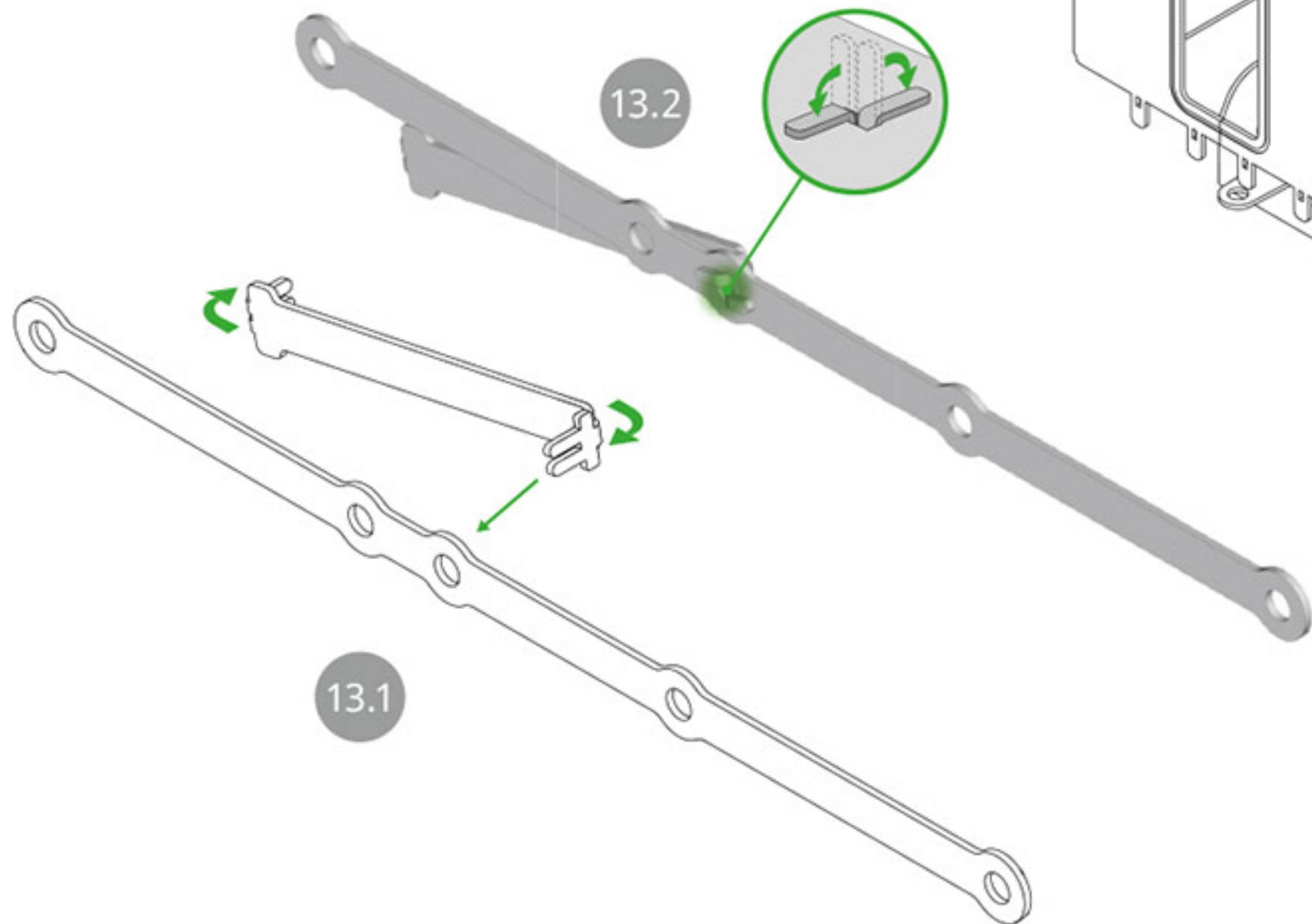
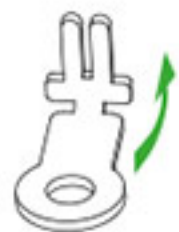

13.1

13.2

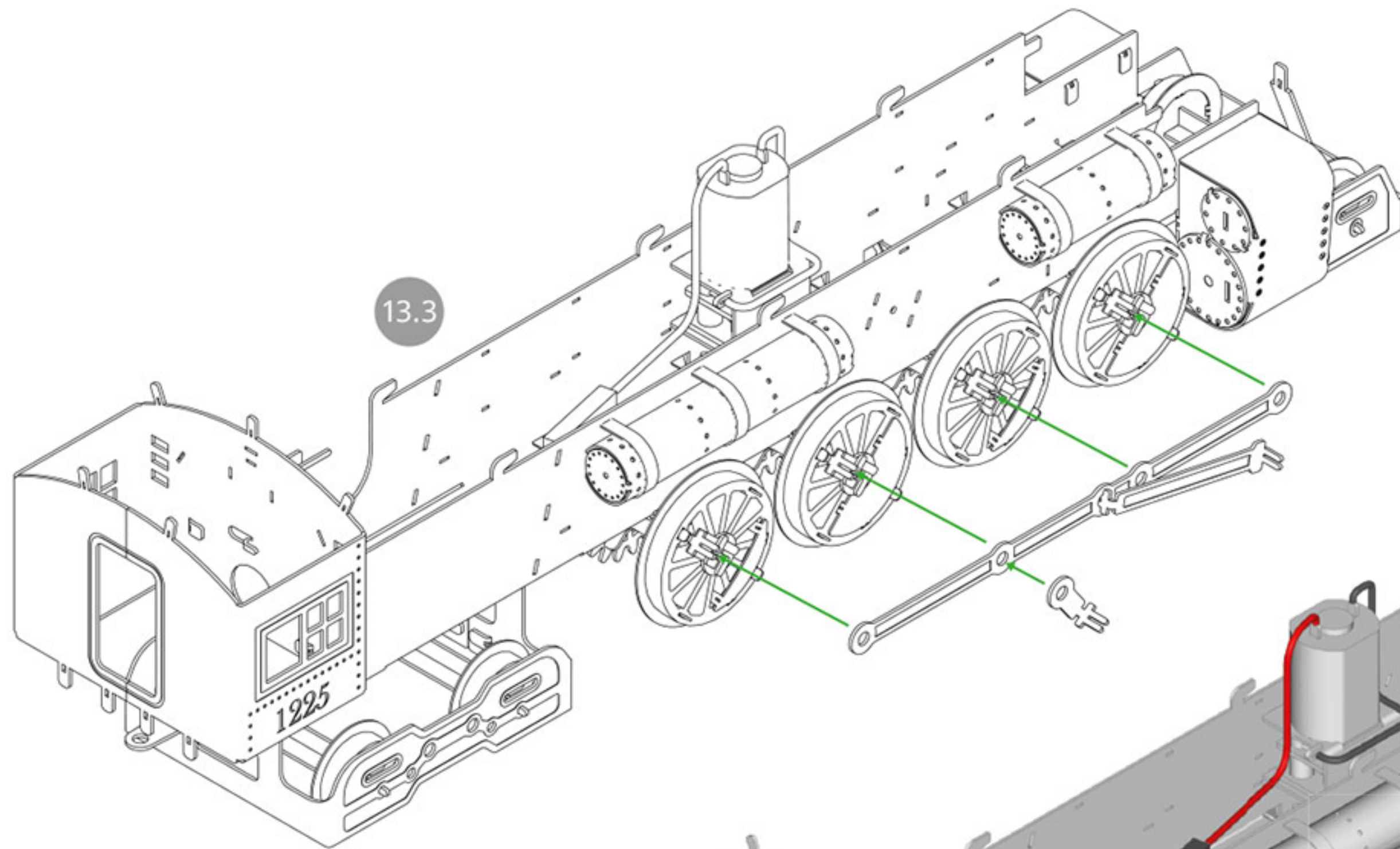

13.3

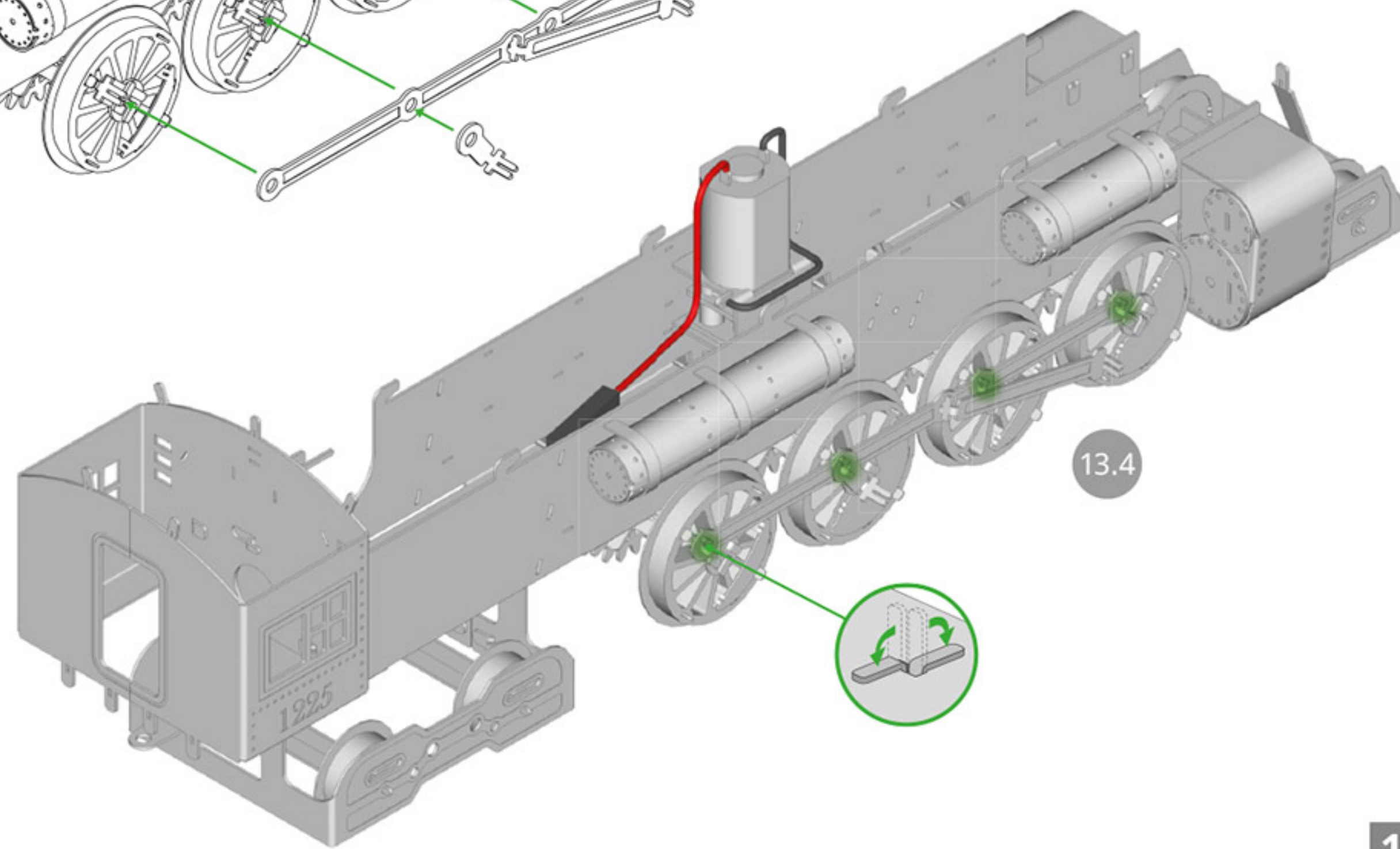

13.4

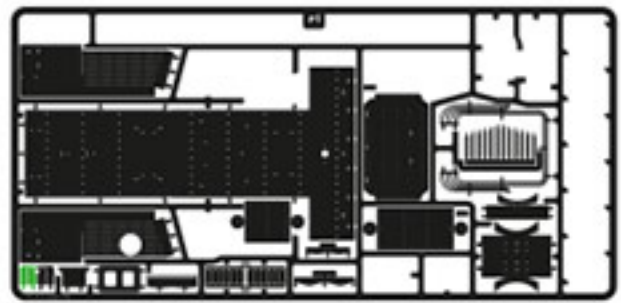

#1



#4



#5

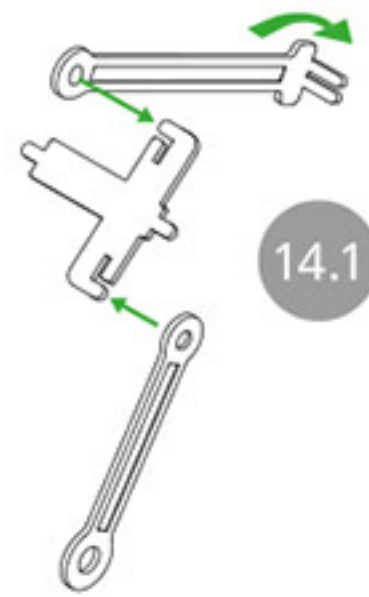

14.1



14.2

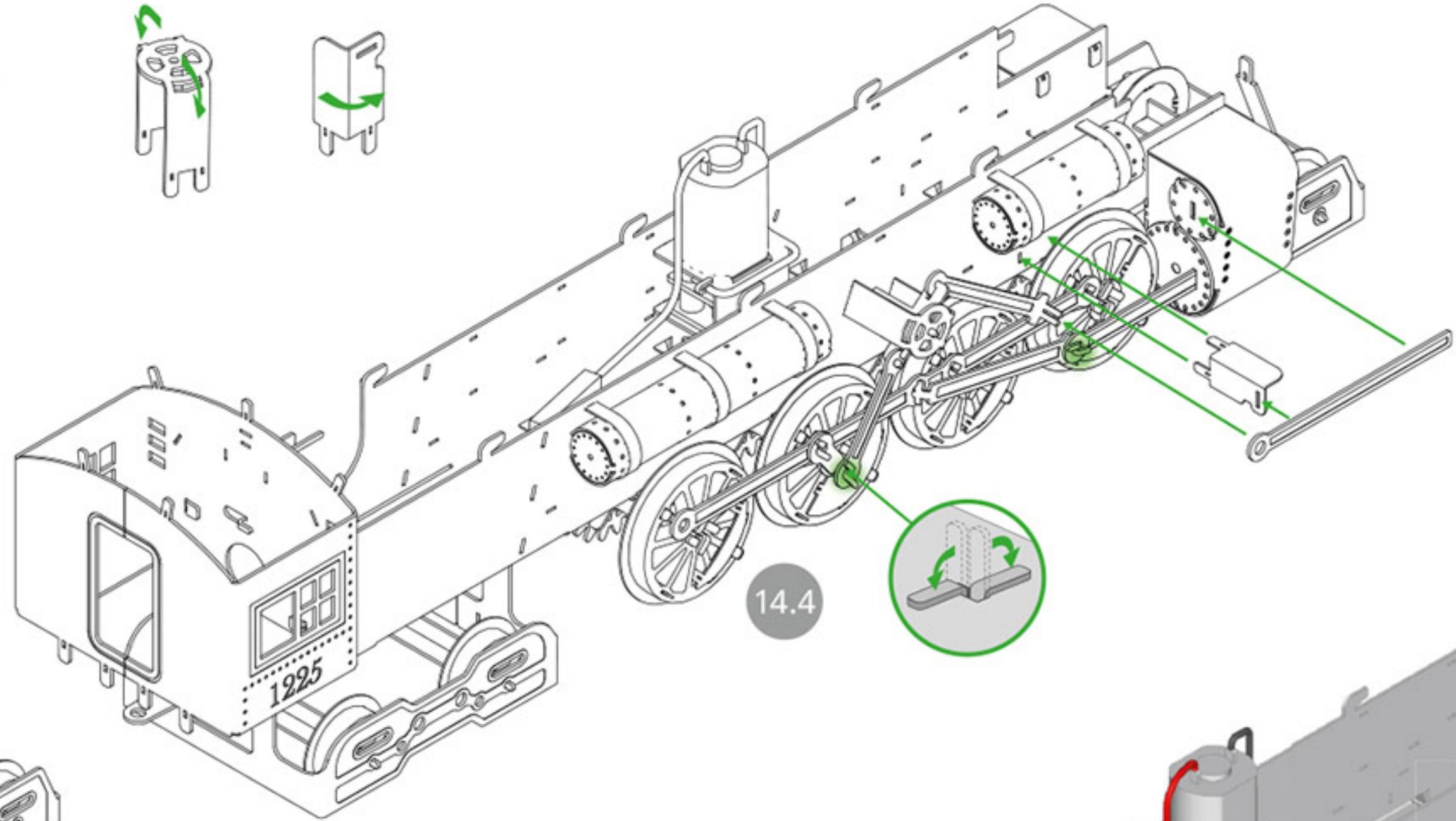
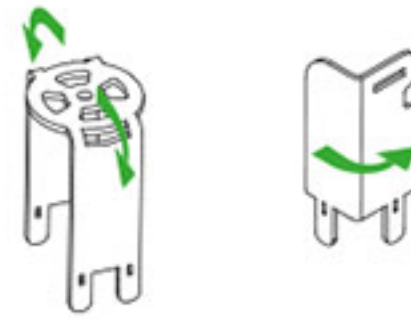

14.4

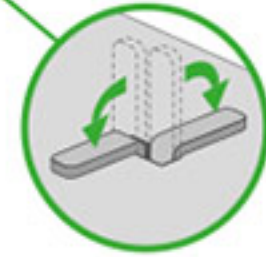

At this step, use this method to fix all unmarked ears

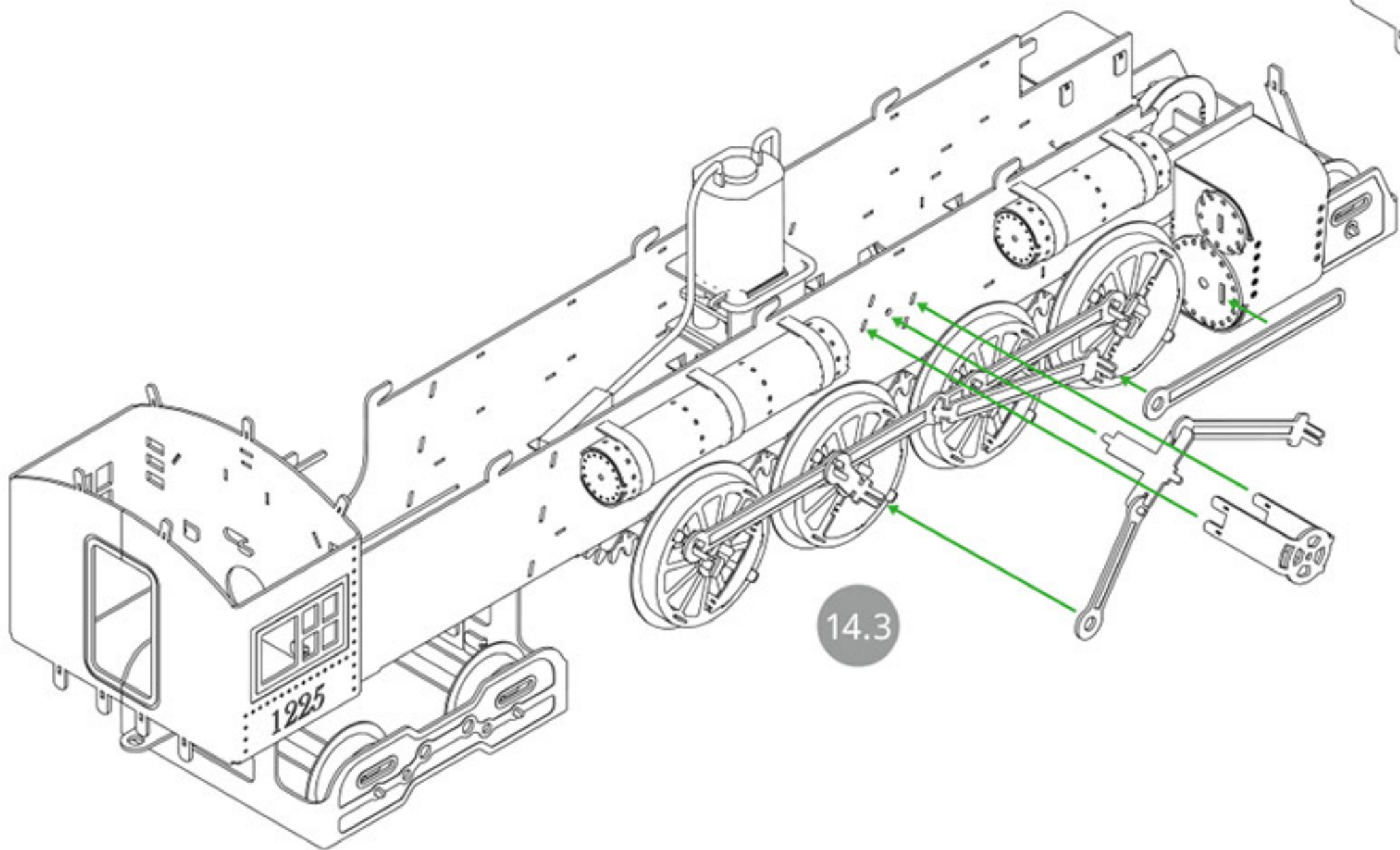

14.3

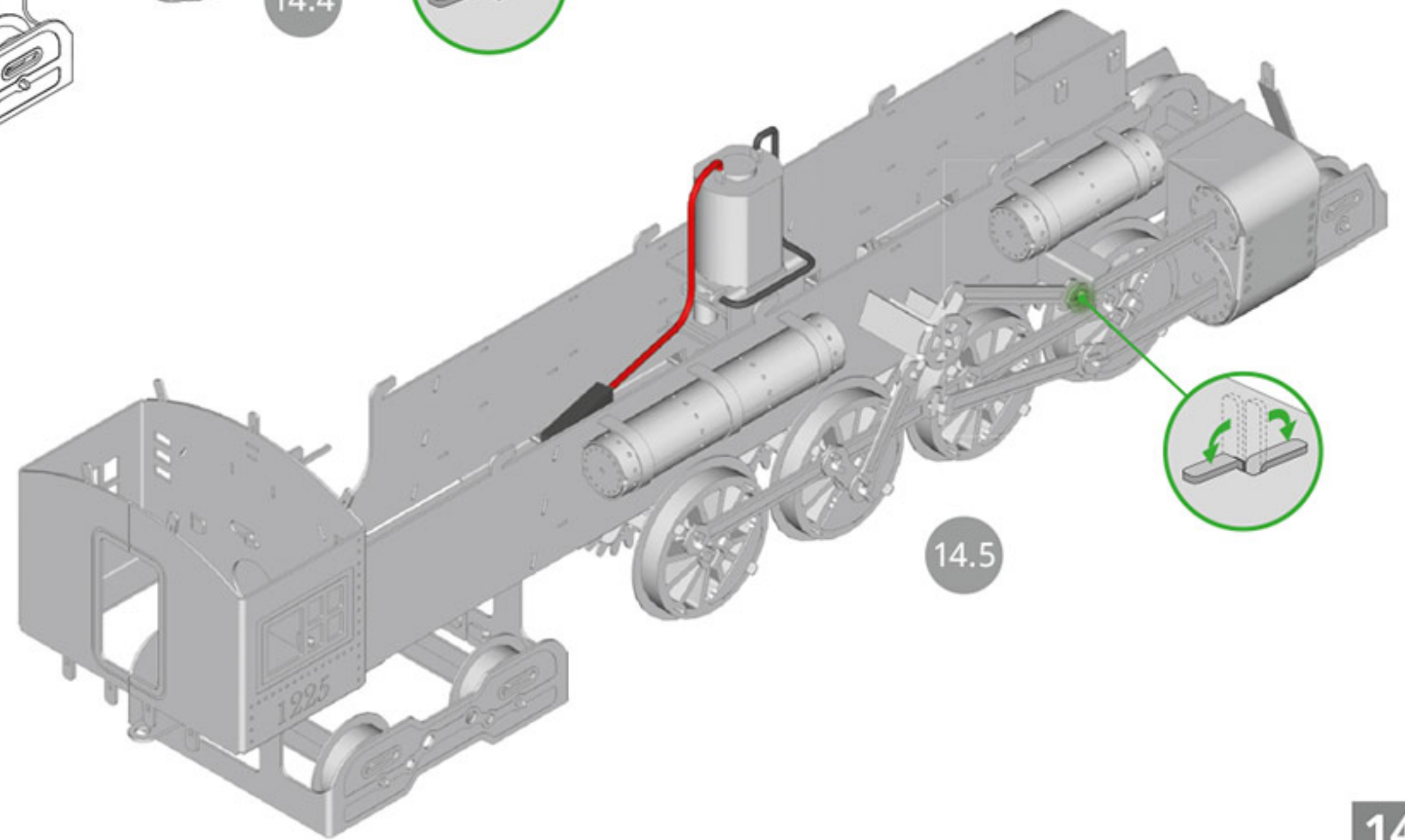

14.5

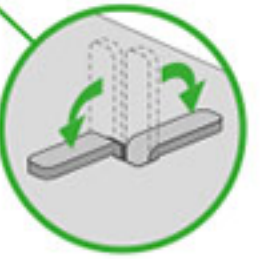



#1

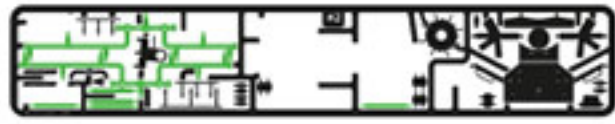

#2



x5

15.1

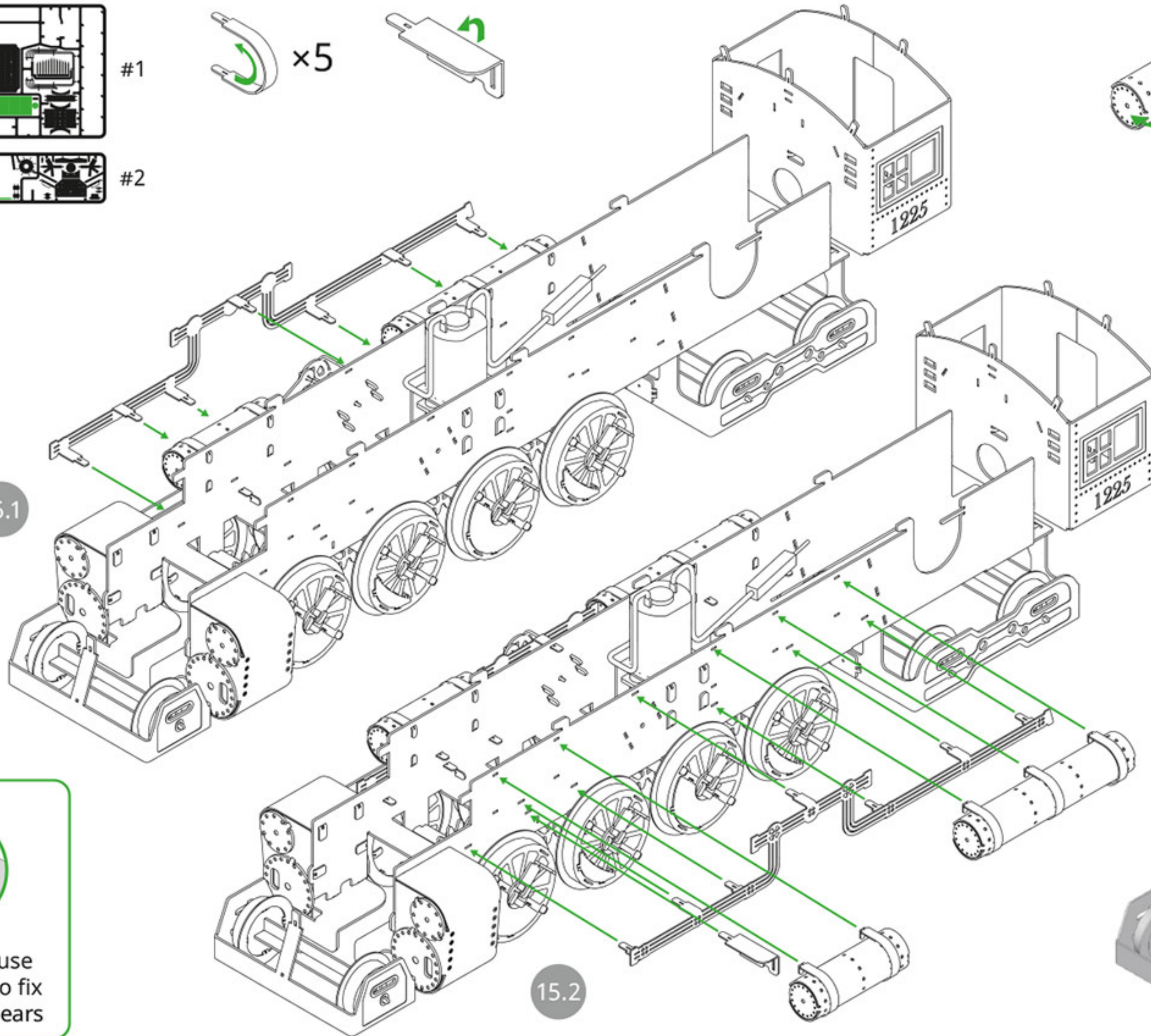

15.2

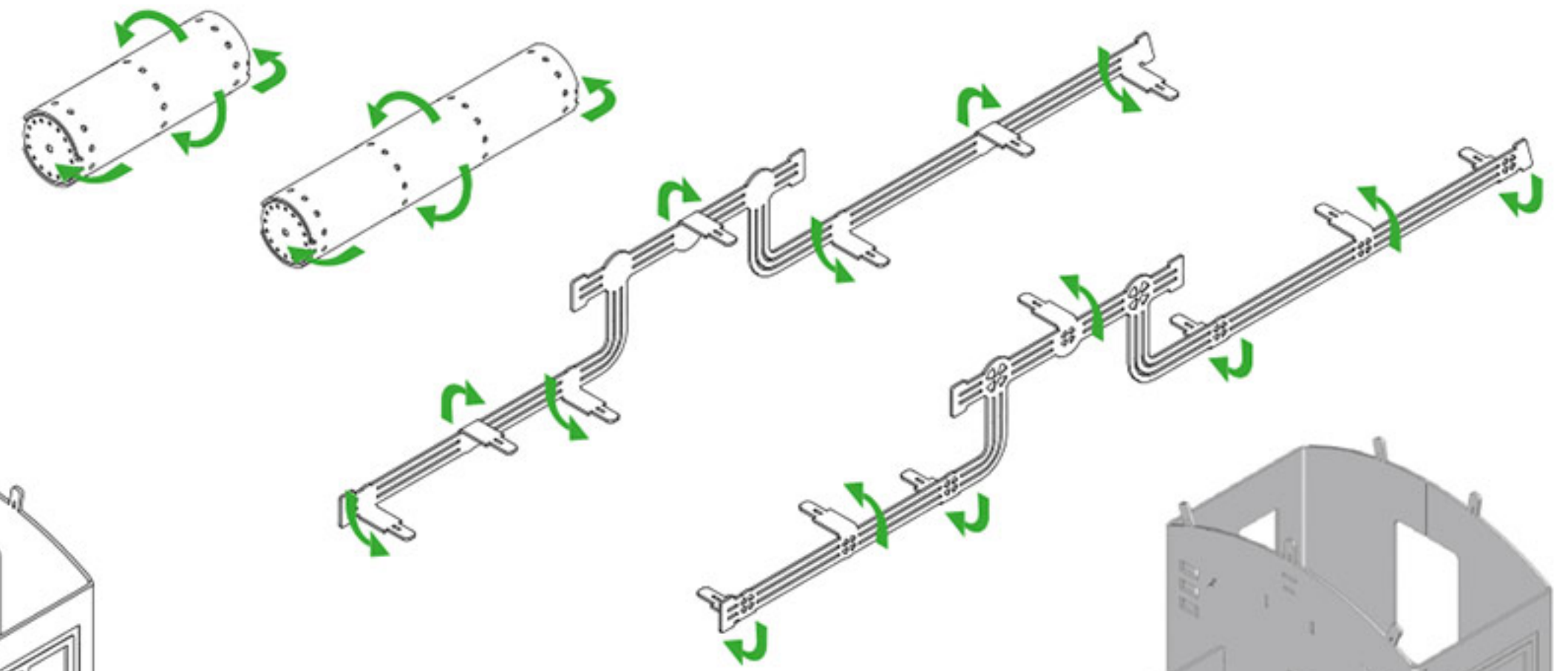

15.3

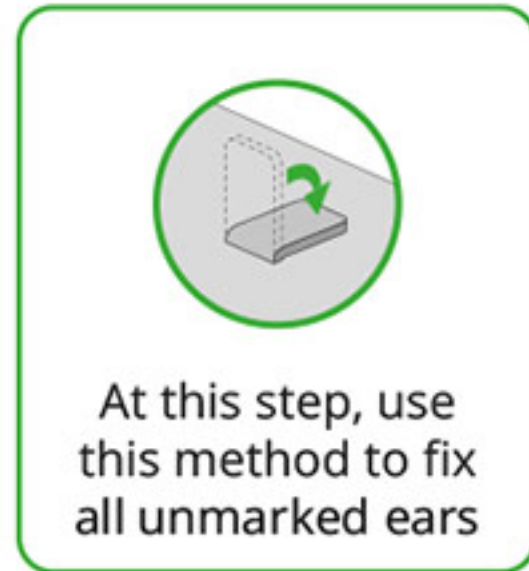
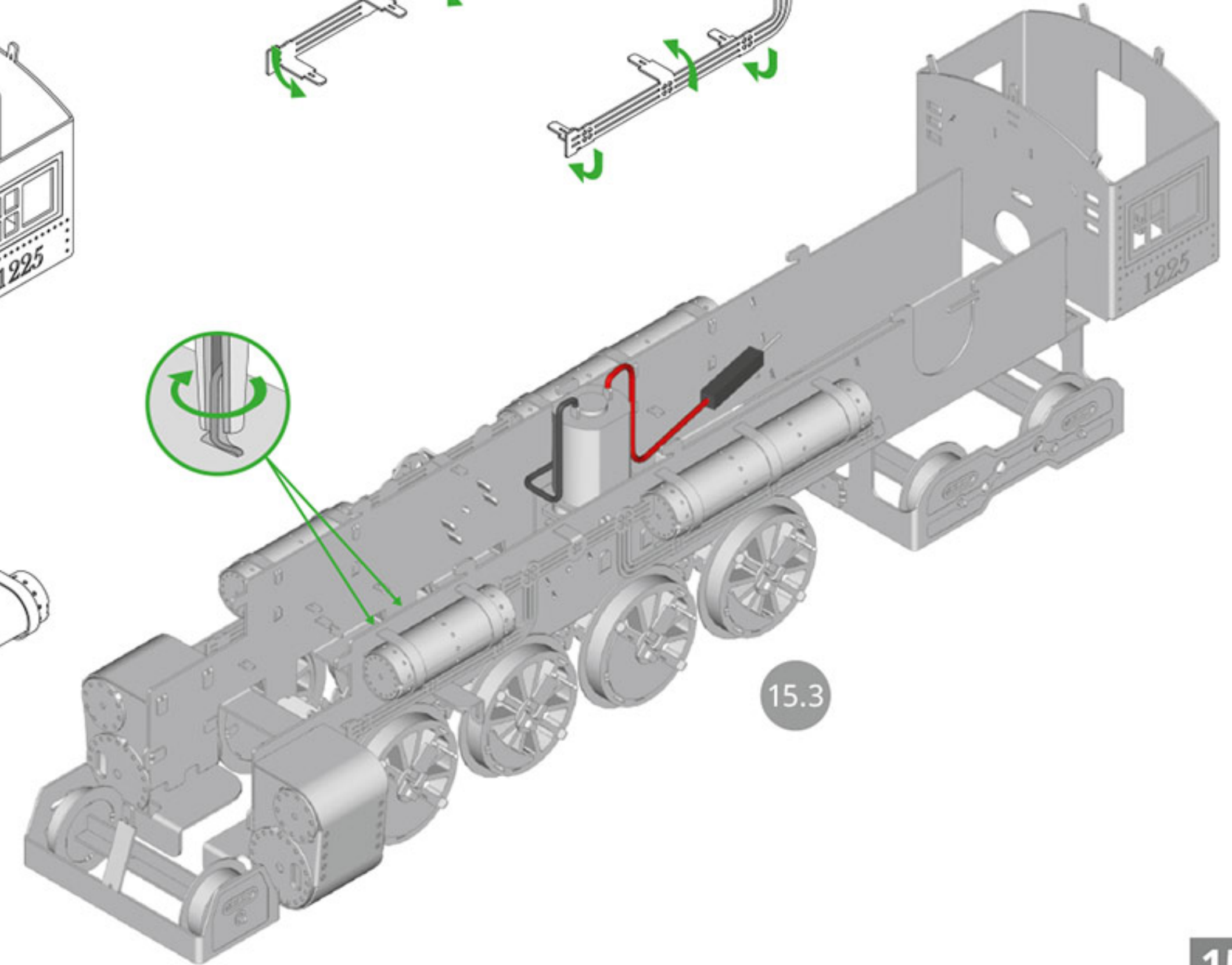

At this step, use this method to fix all unmarked ears





#4



#5

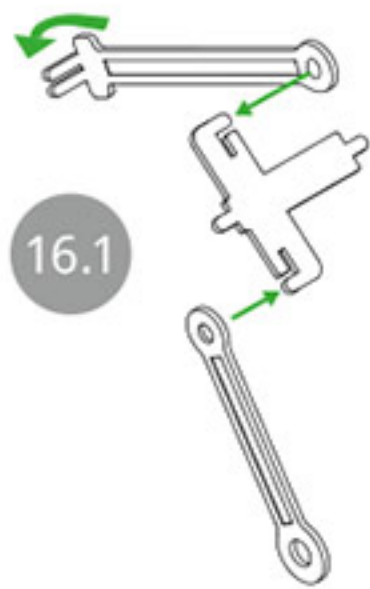

16.1

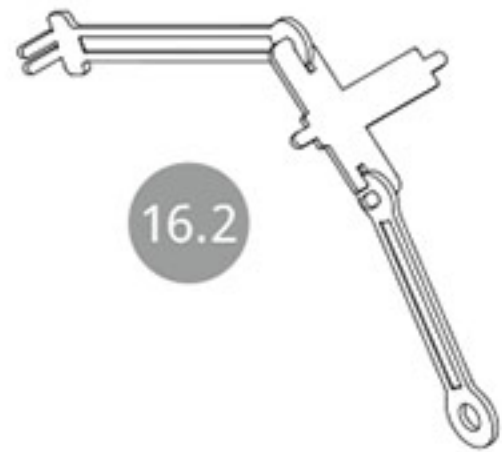

16.2

16.3

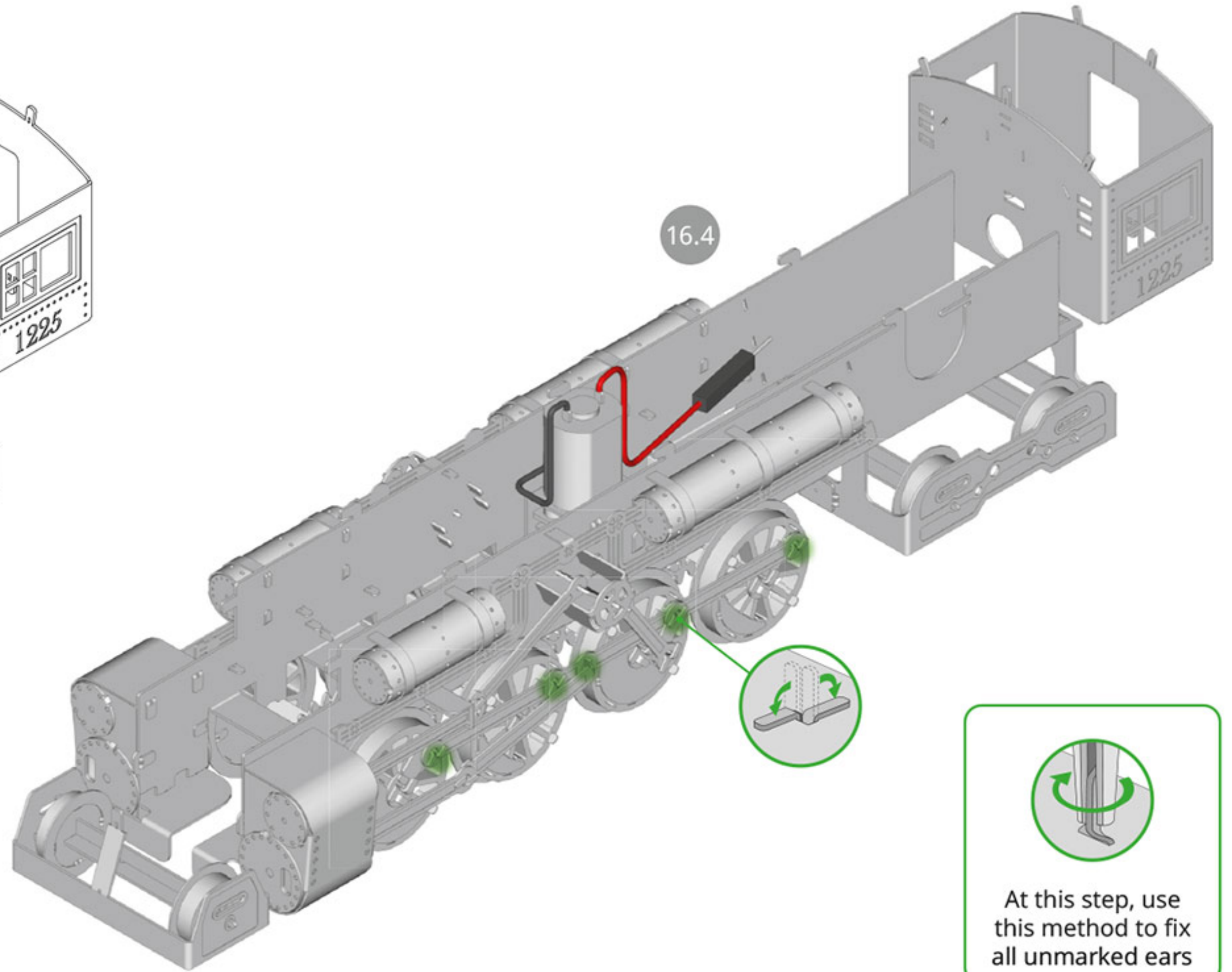
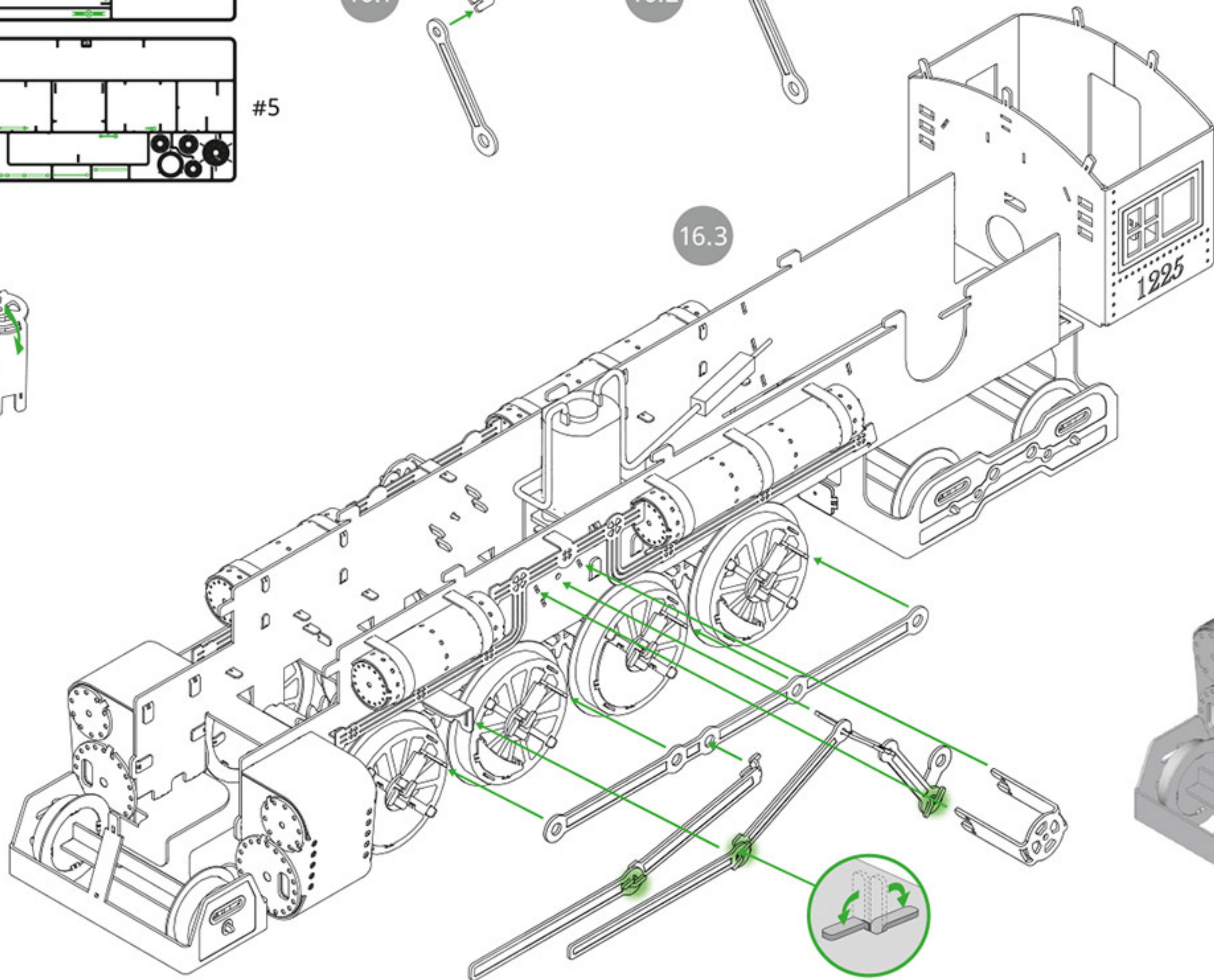

16.4

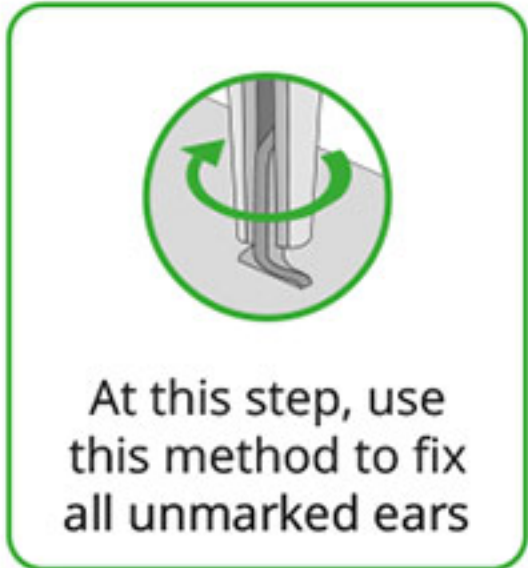

At this step, use this method to fix all unmarked ears



#1



70 mm

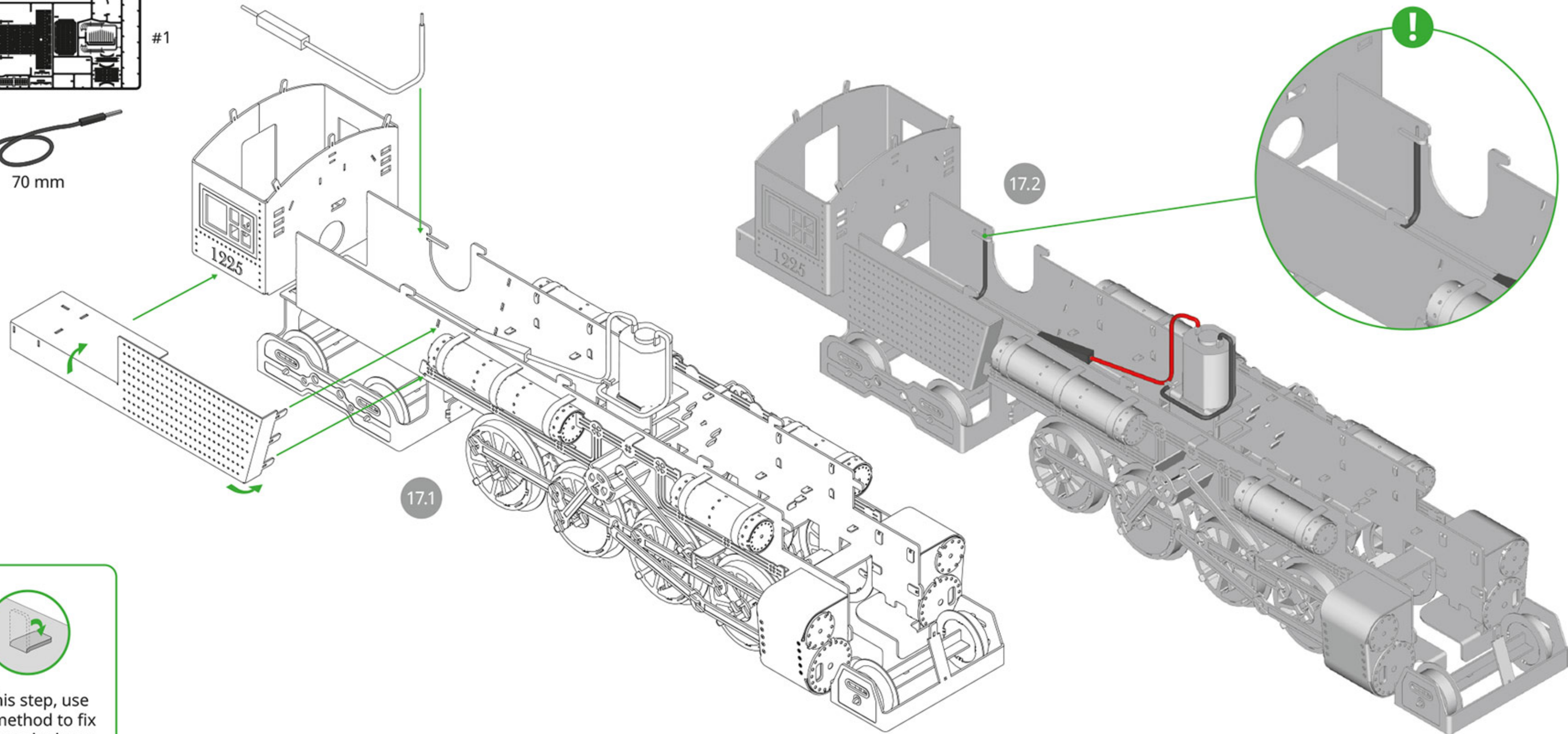

17.1

17.2



At this step, use  
this method to fix  
all unmarked ears

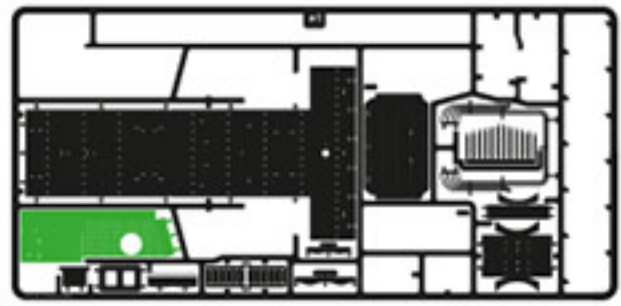

#1



40 mm

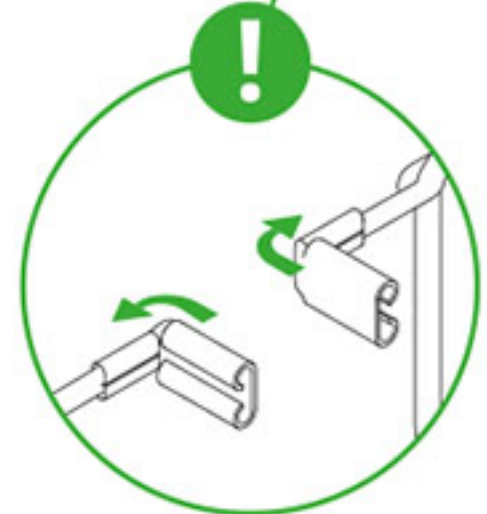

Before installation, bend the terminals at an angle of 90°

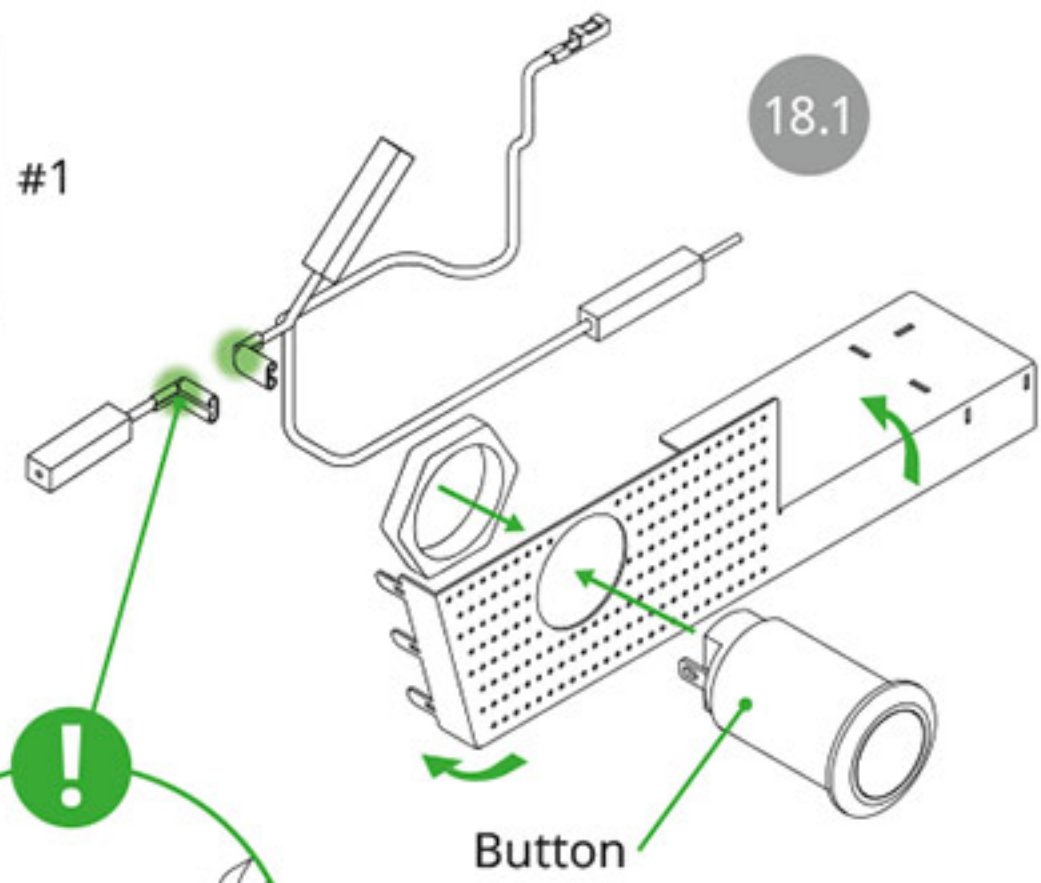

18.1

Button

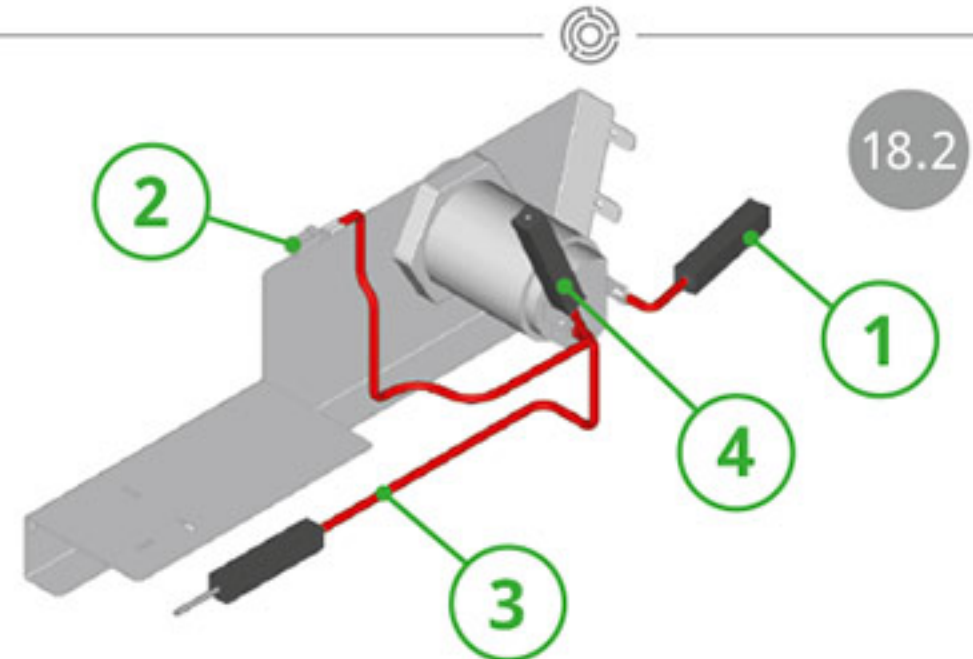

18.2

**!** Before installing, unscrew the nut from the button, then insert the button into the body and fix the button with the nut

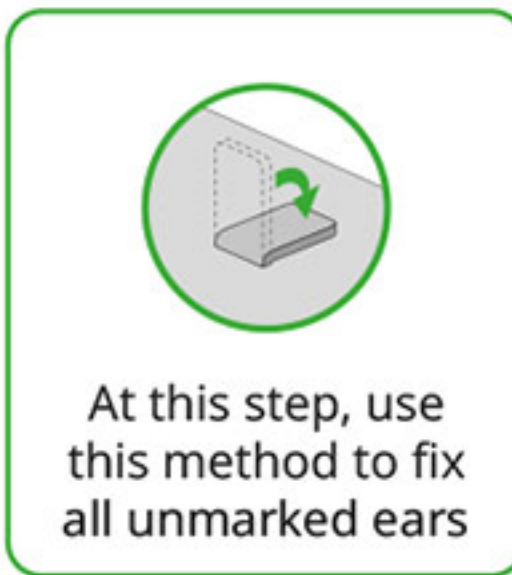

At this step, use this method to fix all unmarked ears

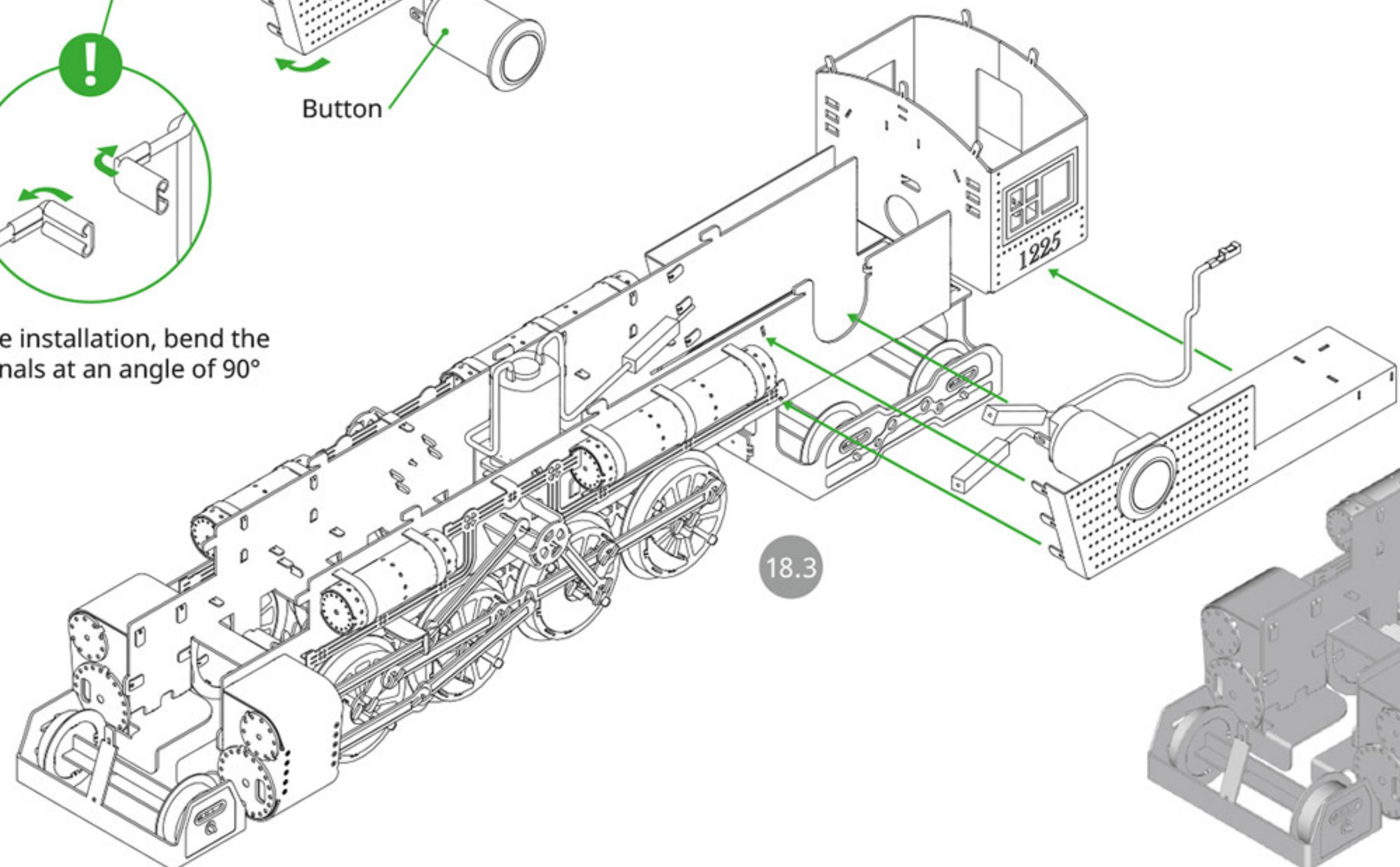

18.3

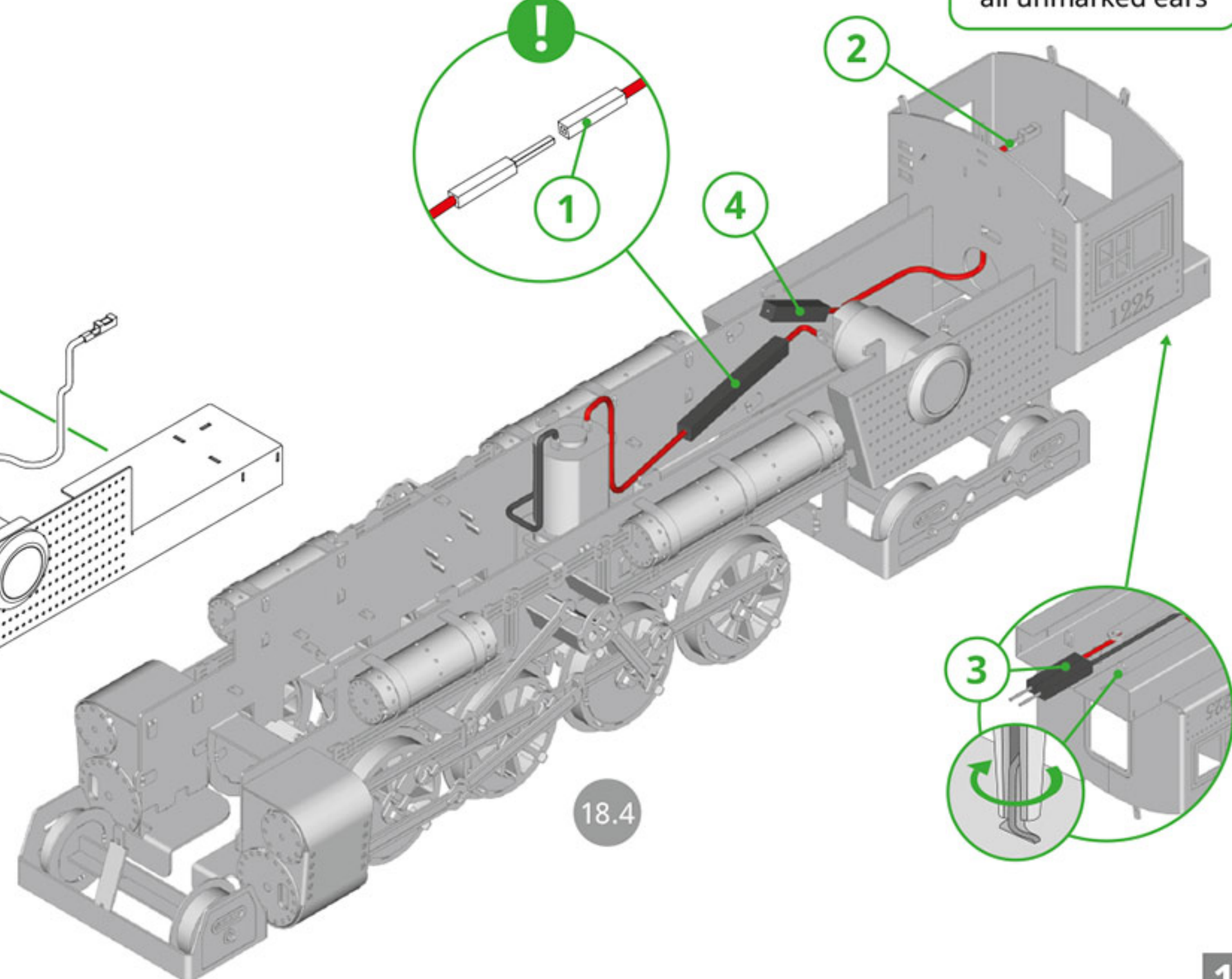

18.4

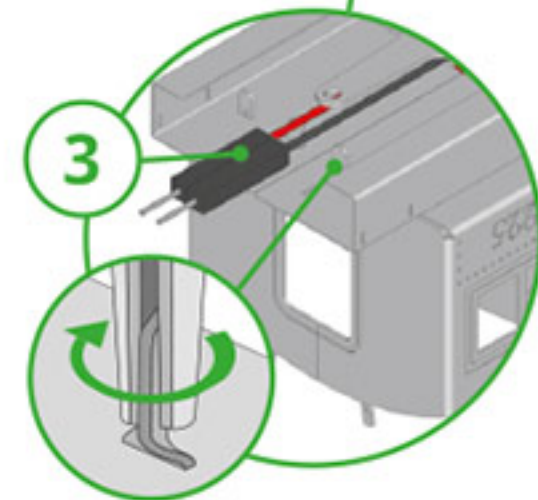
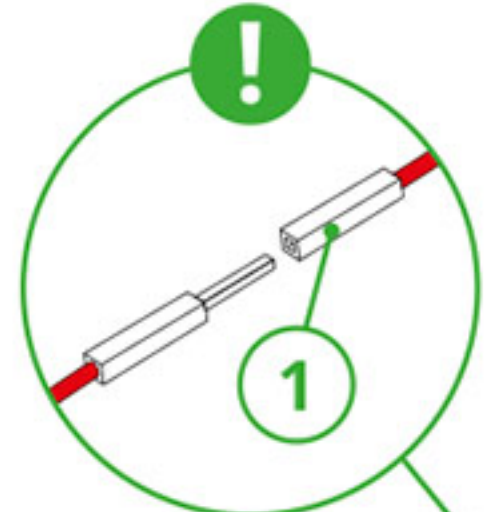

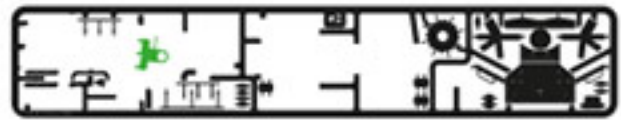

#2



#4

Light-emitting diode

19.1

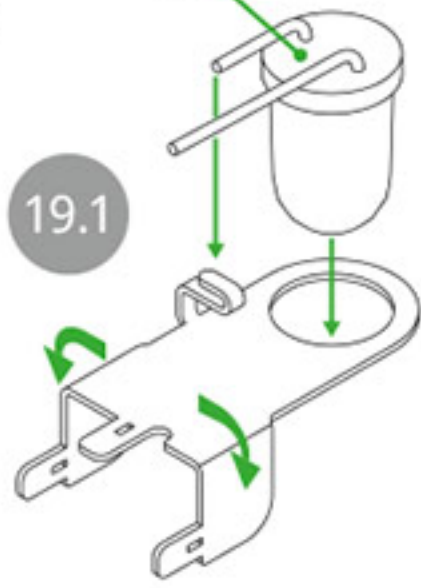

19.2

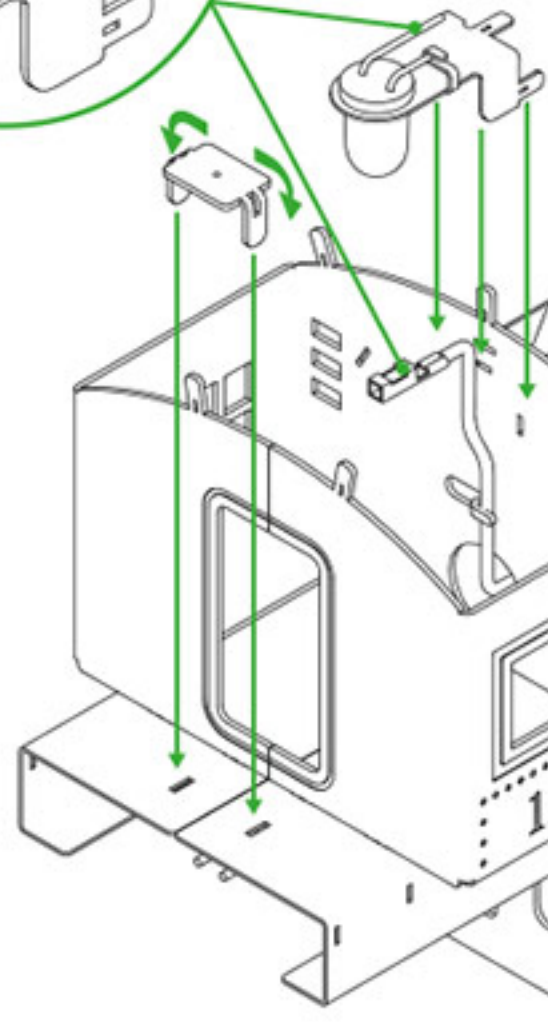
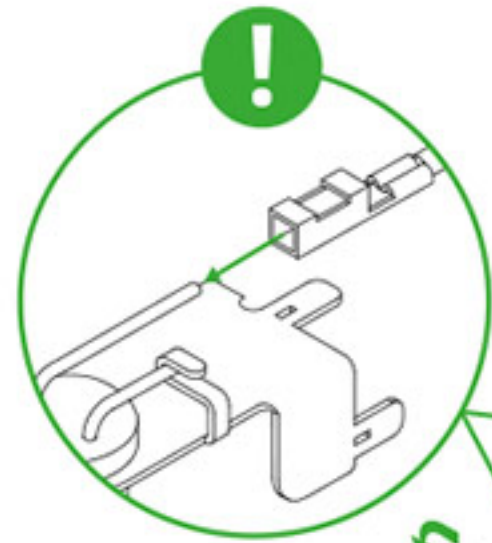

19.3

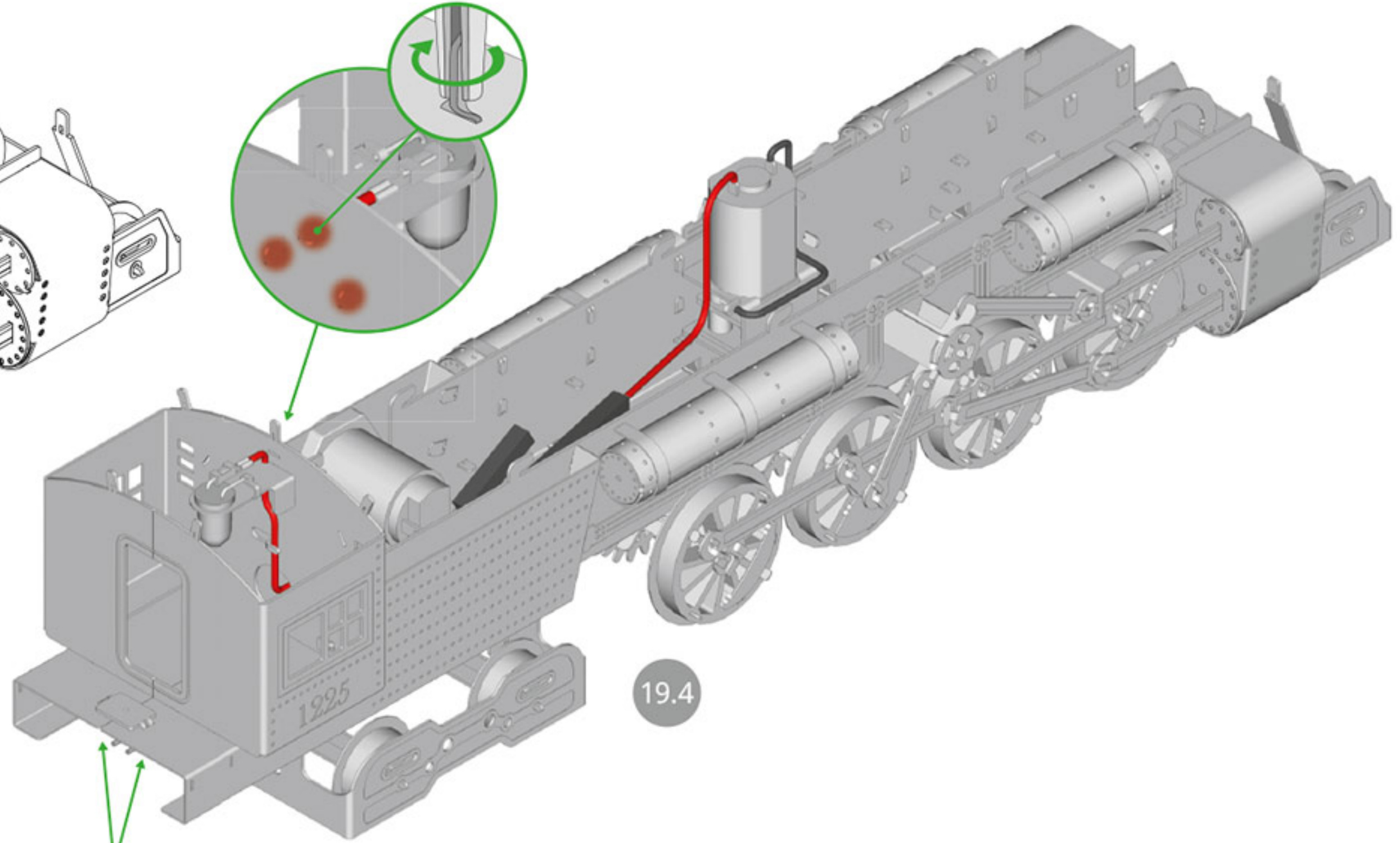
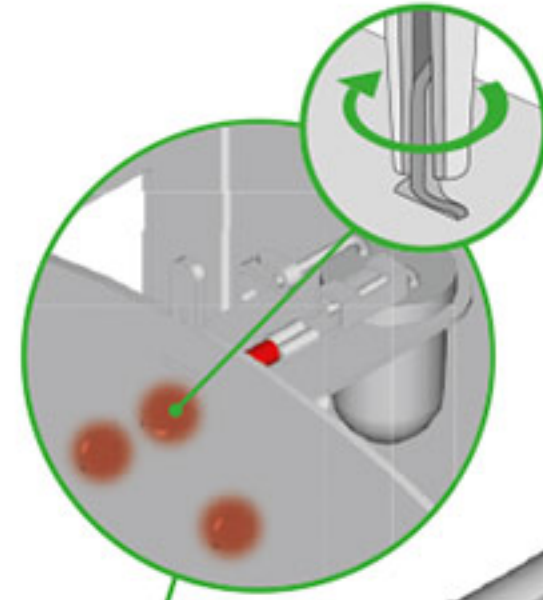

19.4

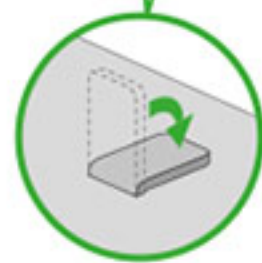

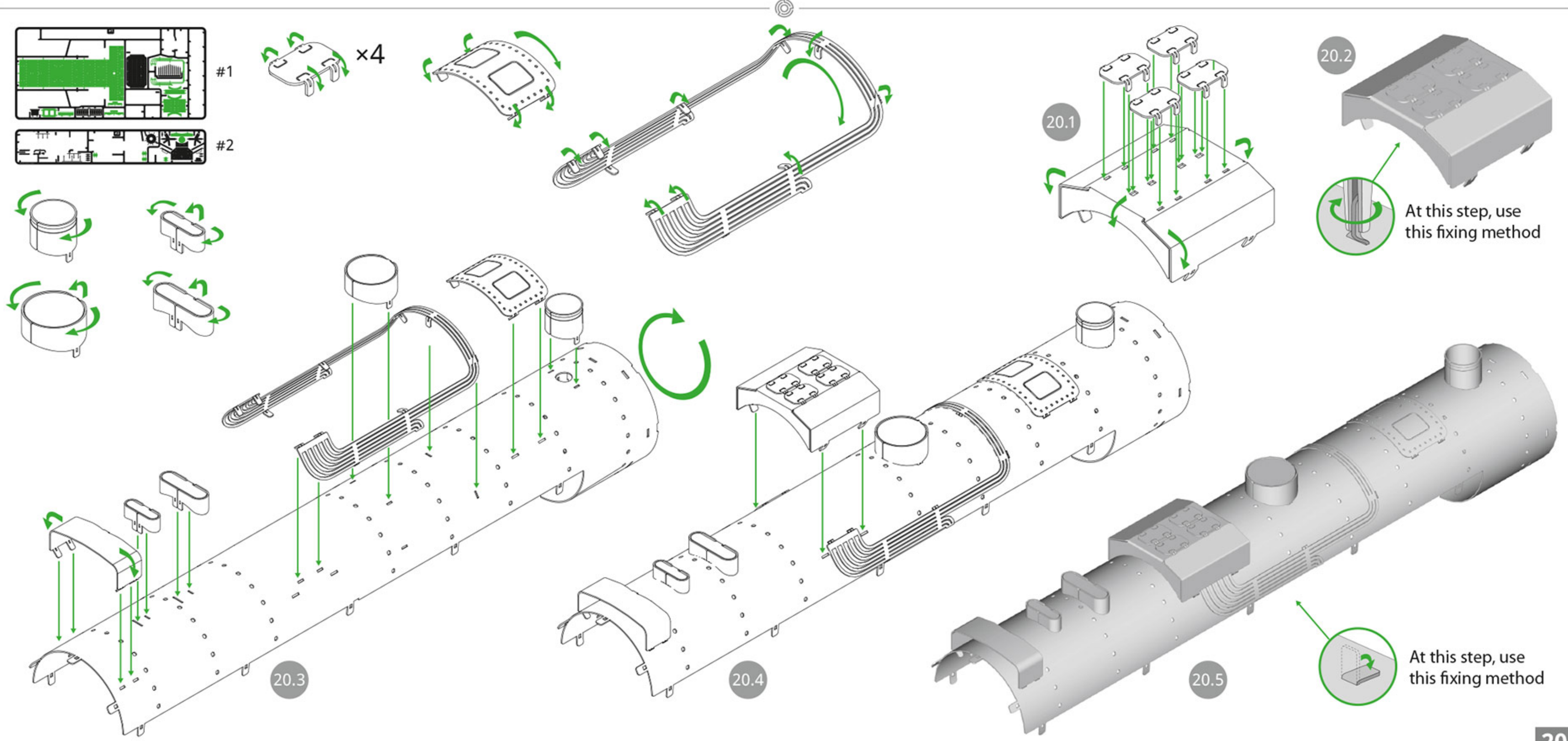

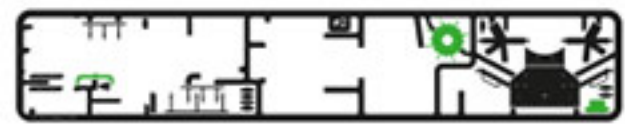

#2

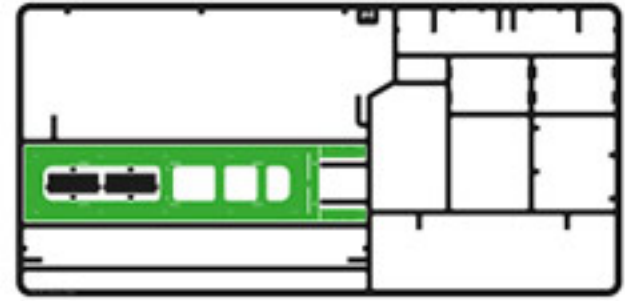

#4

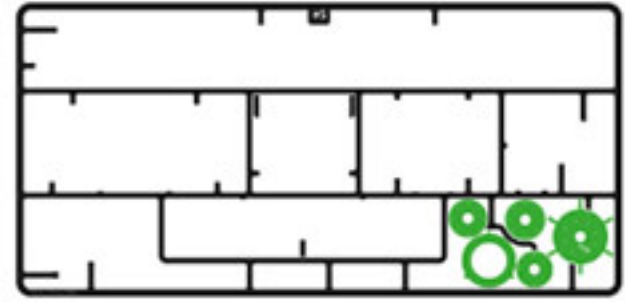

#5



190 mm

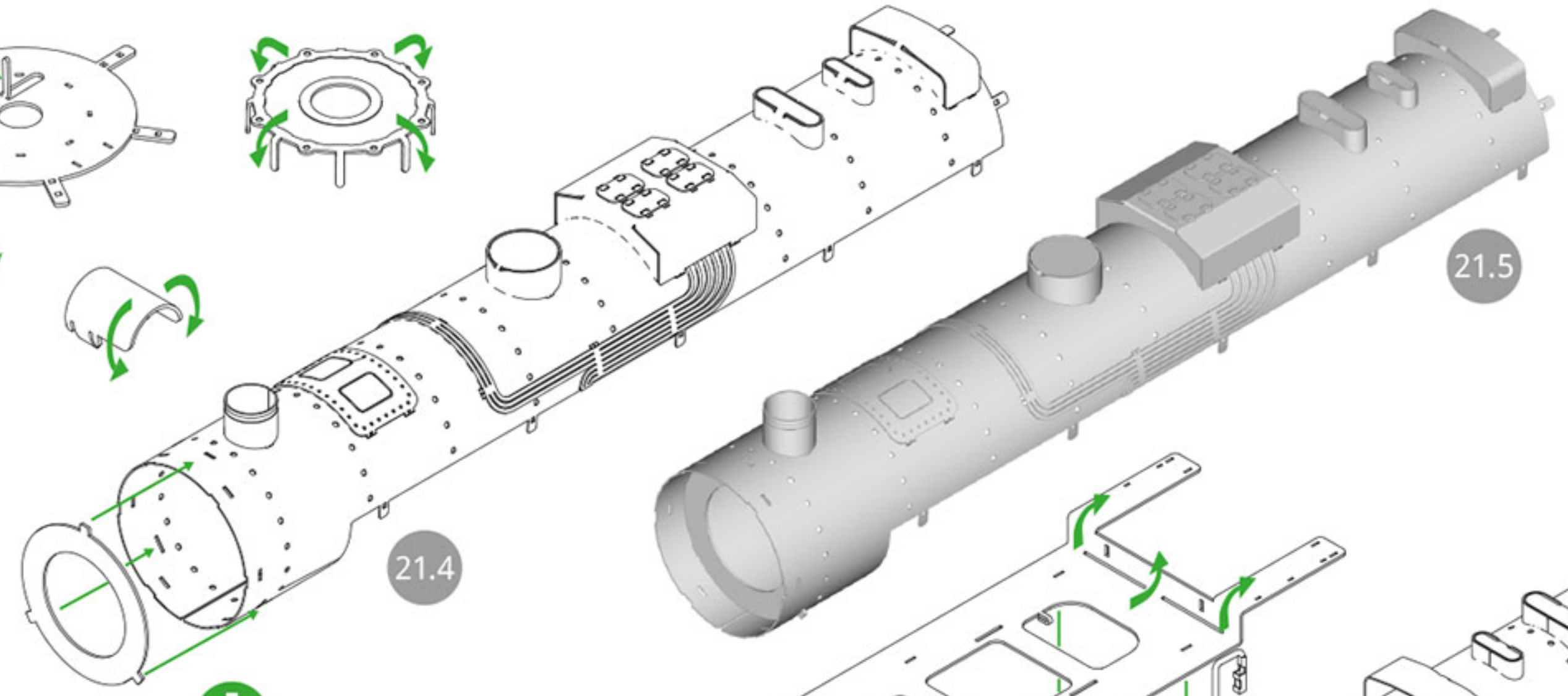
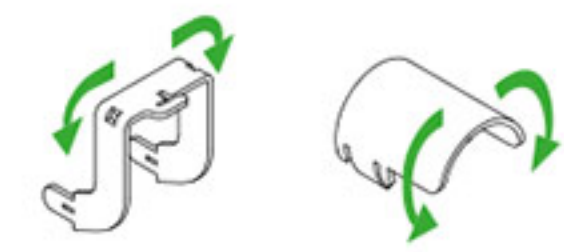
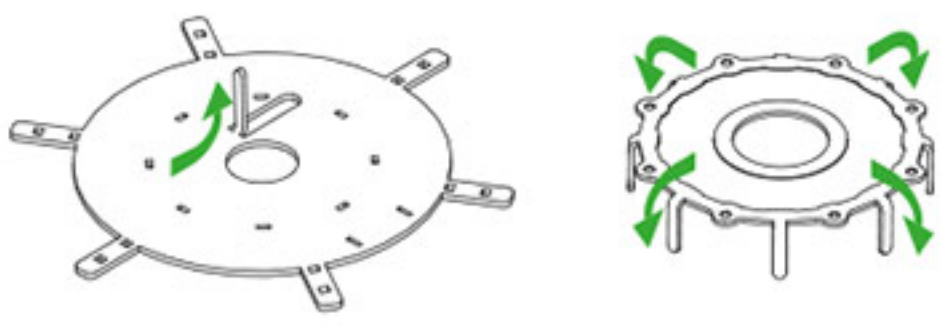

21.4

21.5

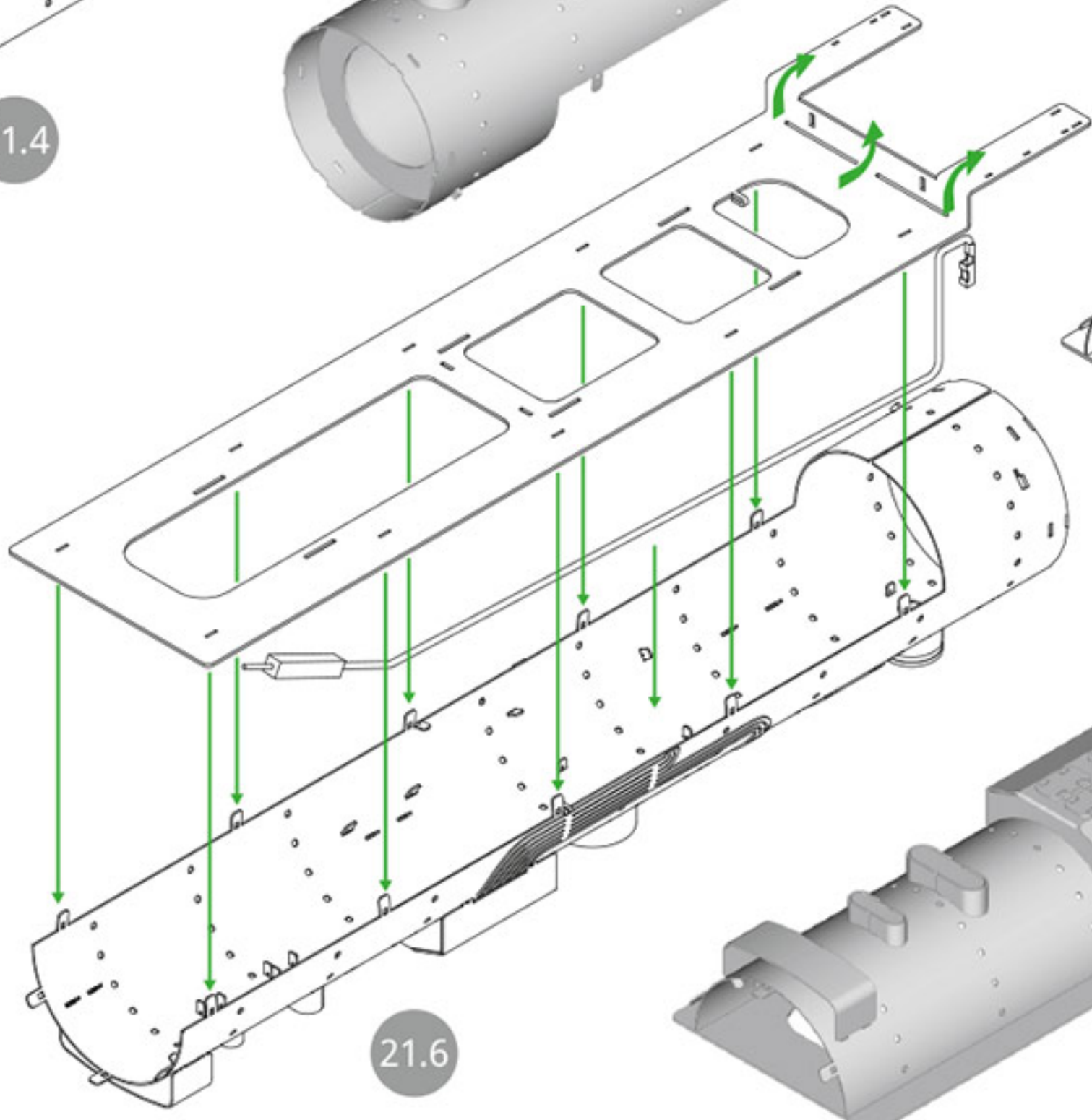

21.6

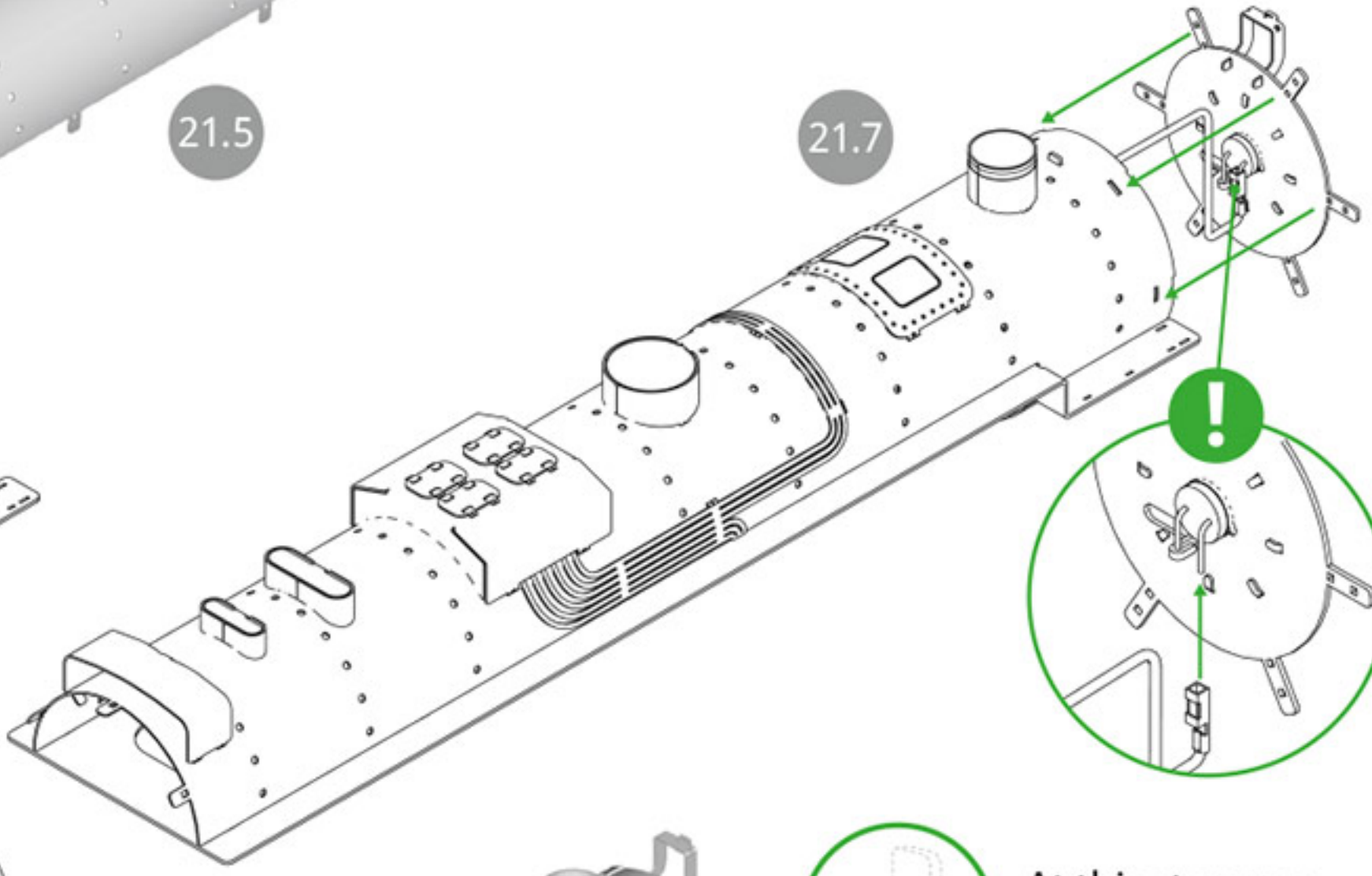

21.7

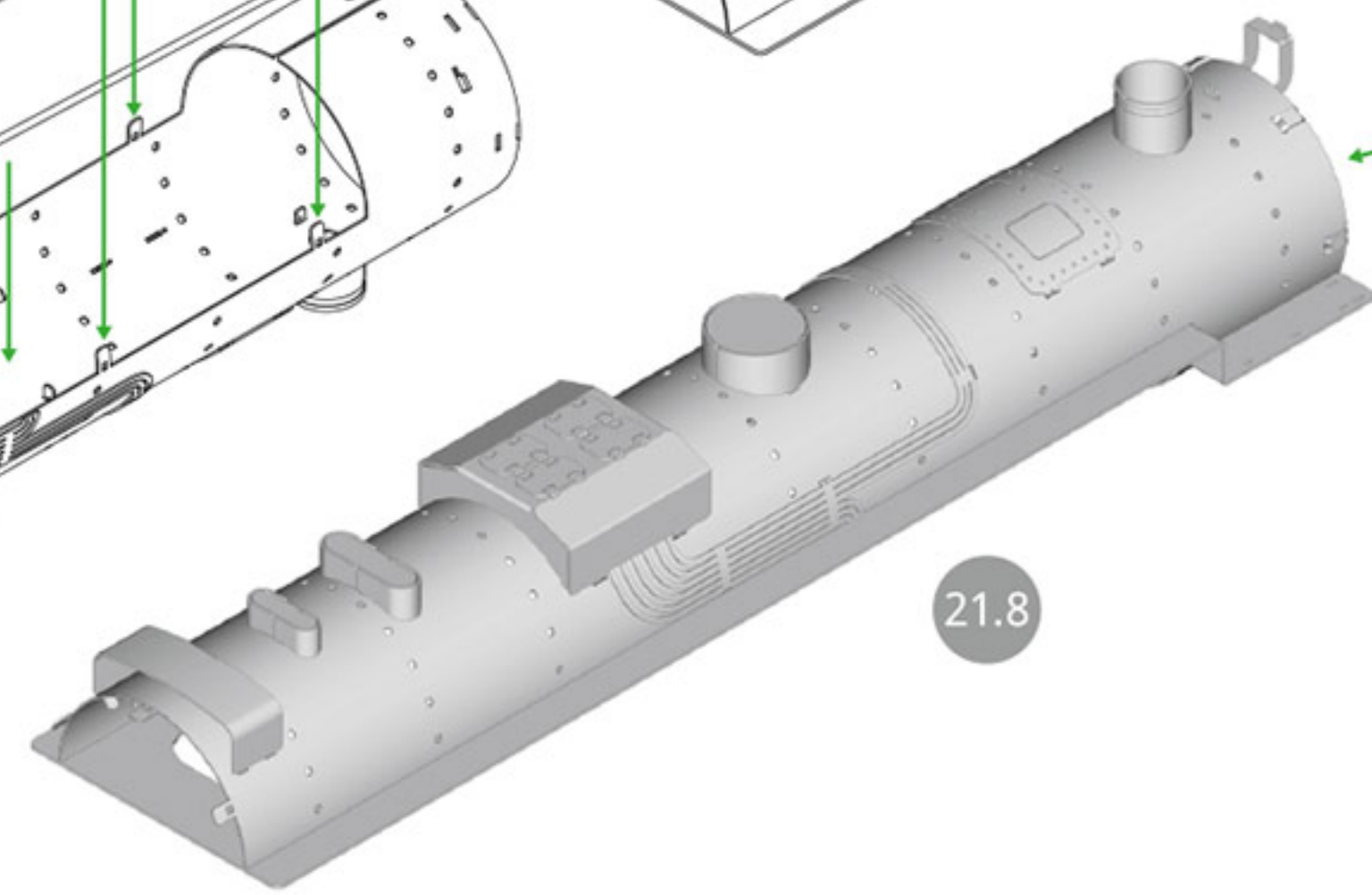

21.8

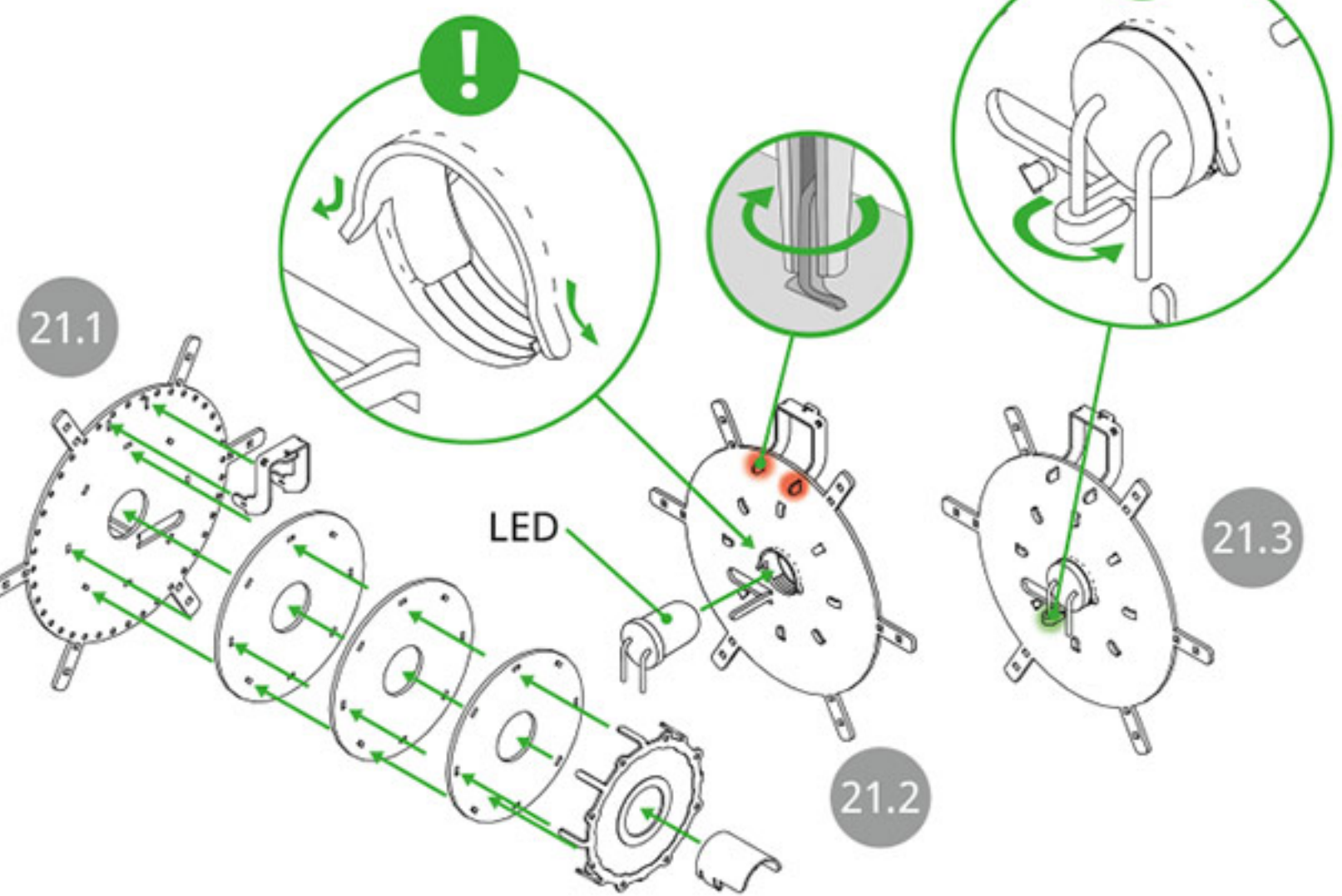
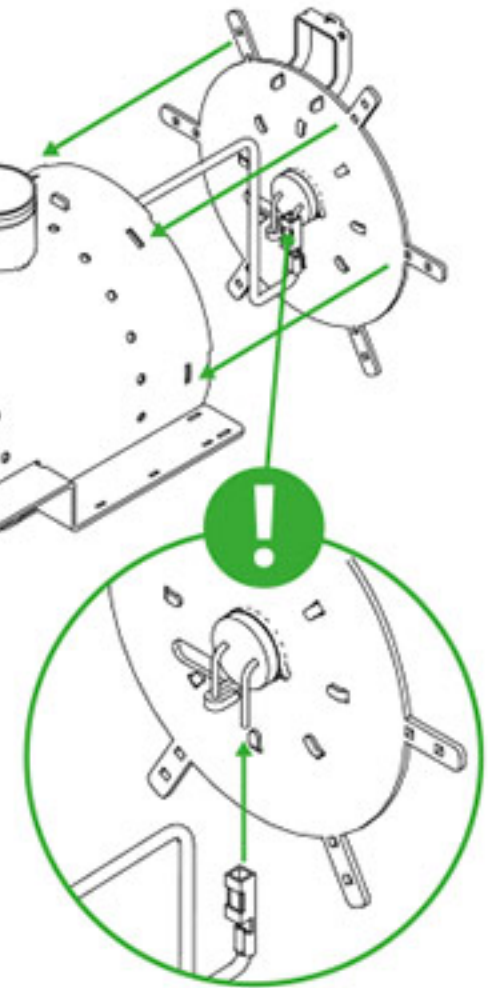

21.1

LED

21.2

21.3



At this step, use this fixing method

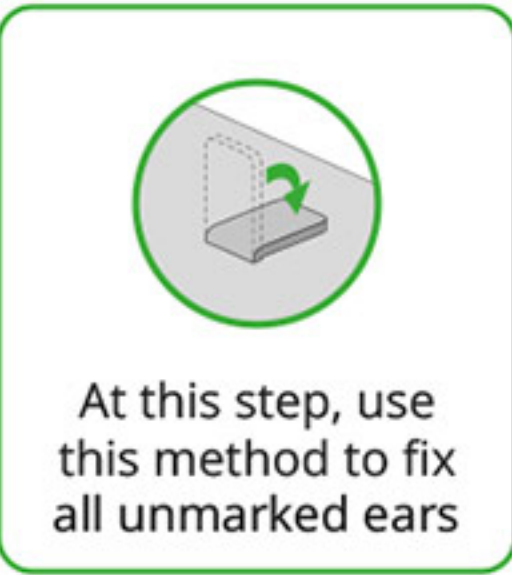

At this step, use this method to fix all unmarked ears

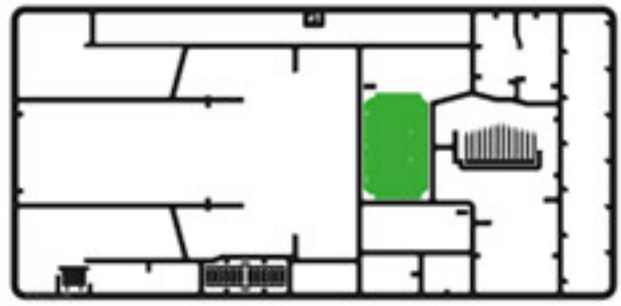

#1

22.1

4

Assembly step 19

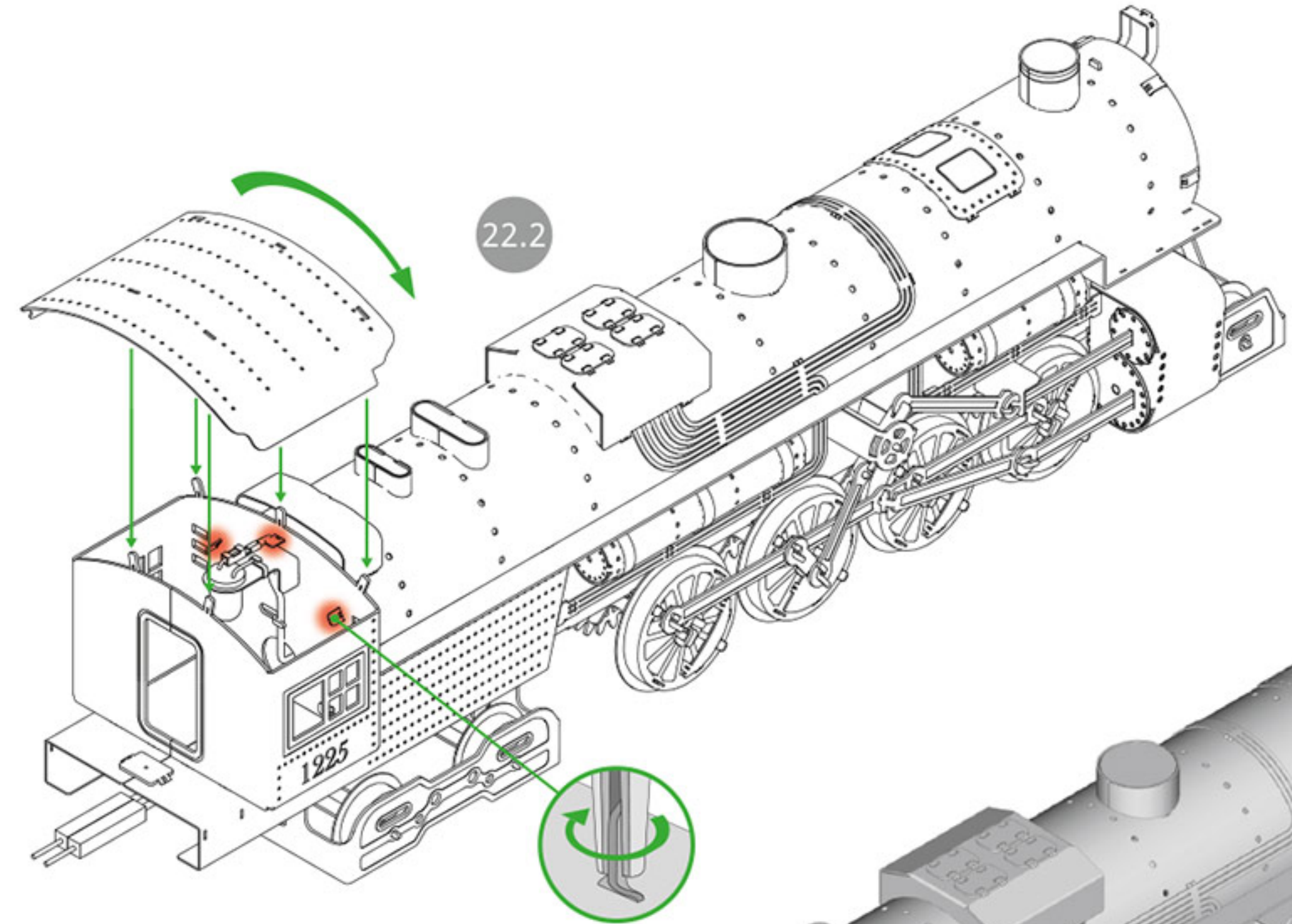
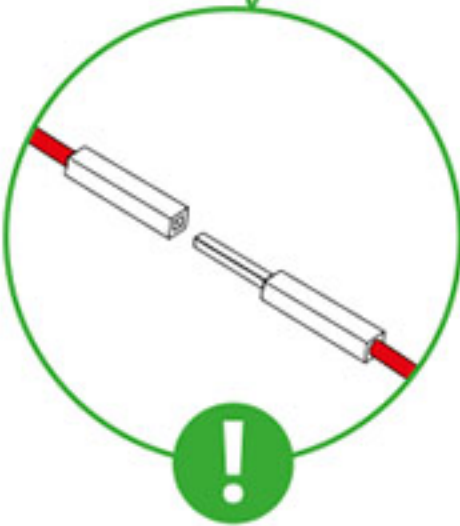

22.2

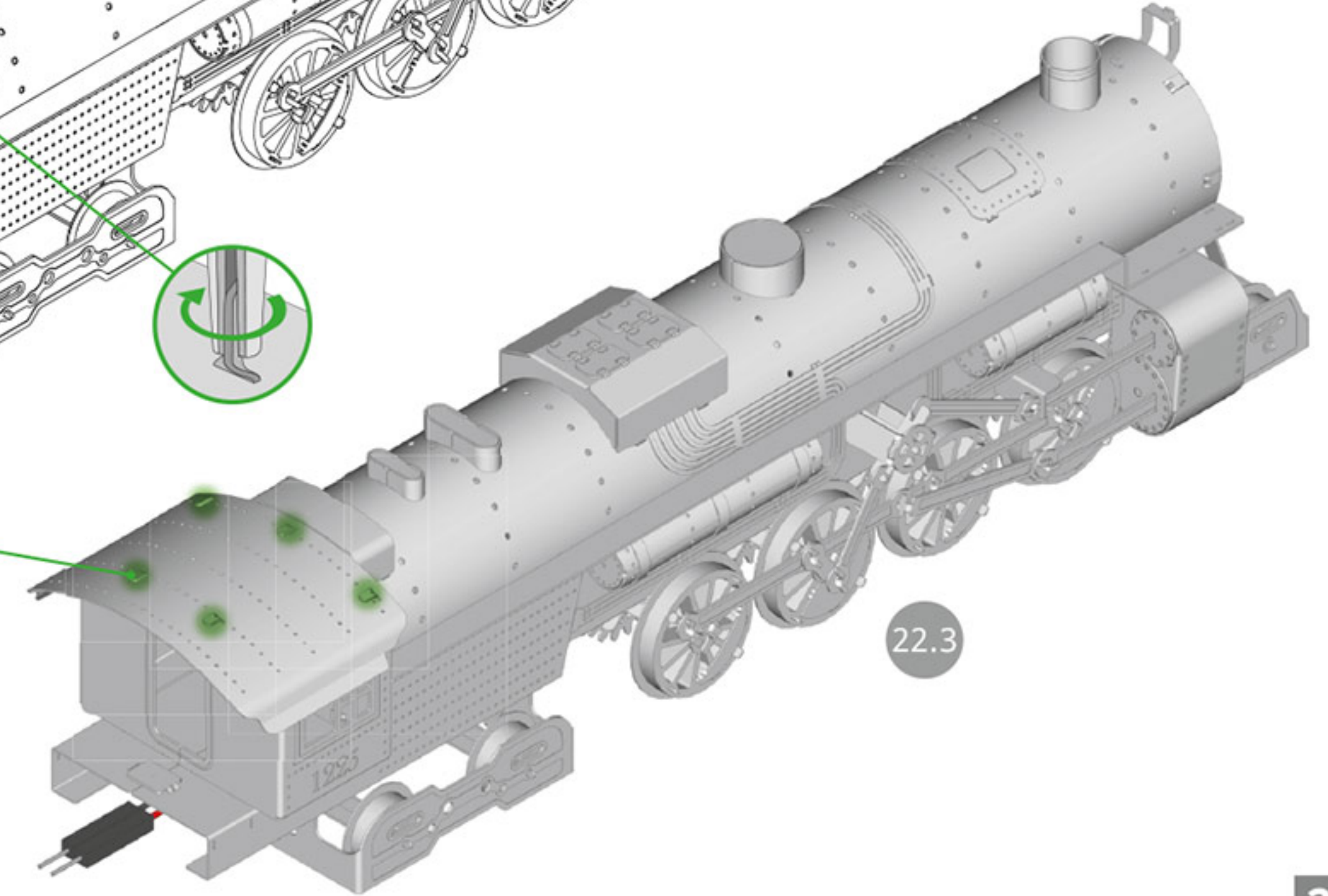

22.3



#1  
#2

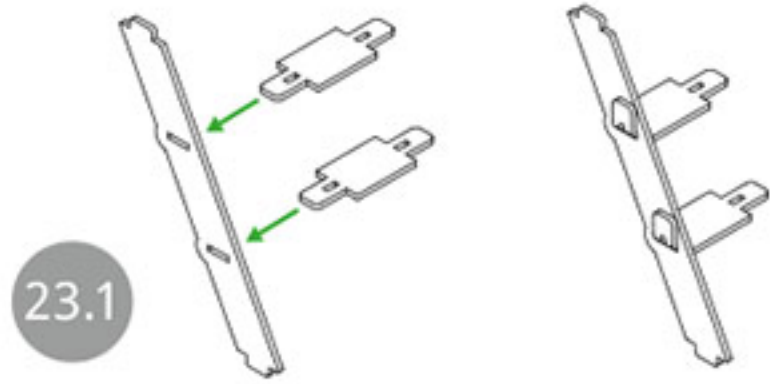
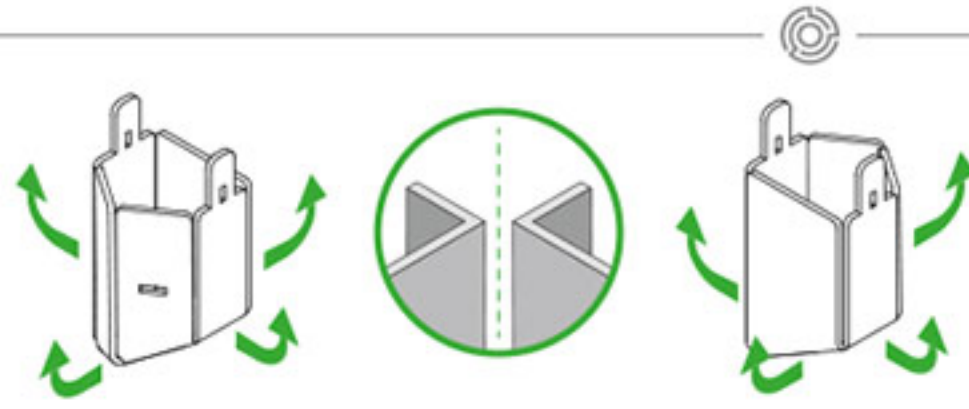
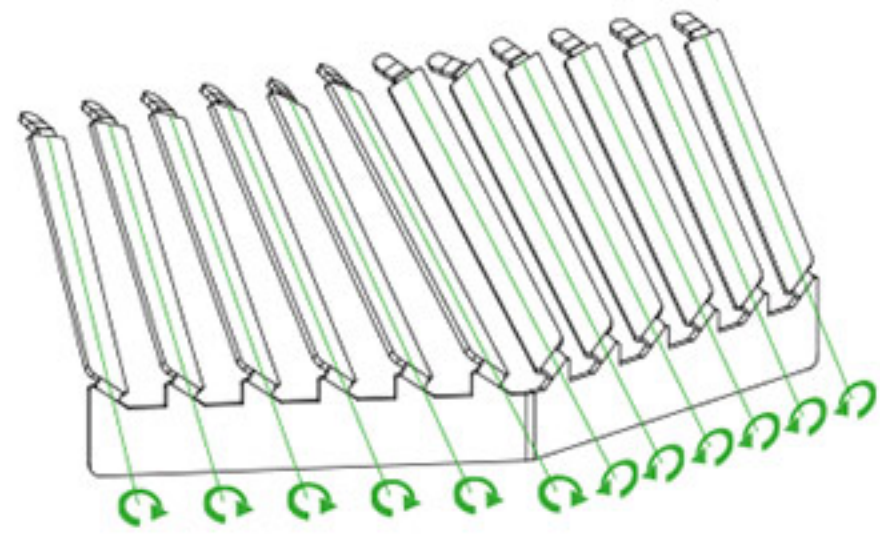

23.1

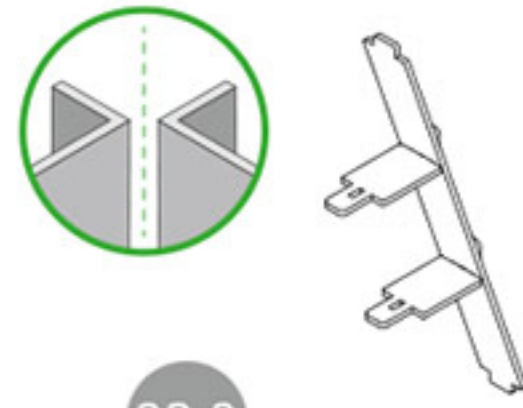

23.2

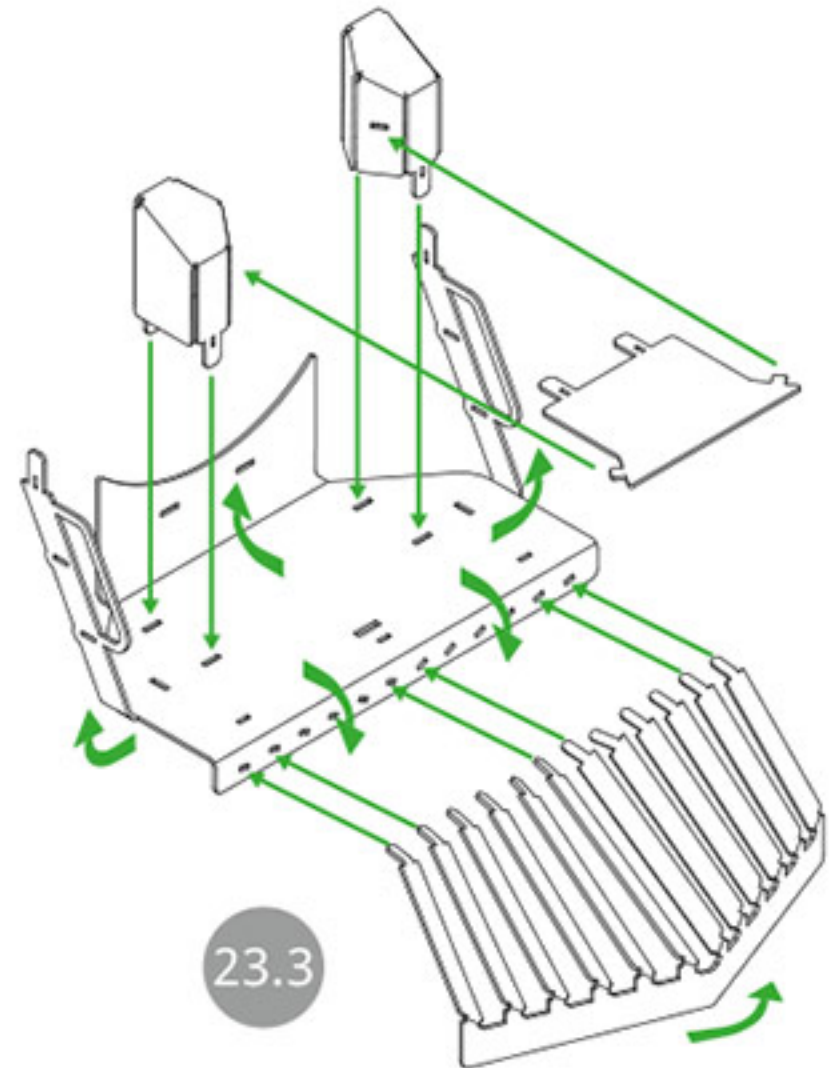

23.3

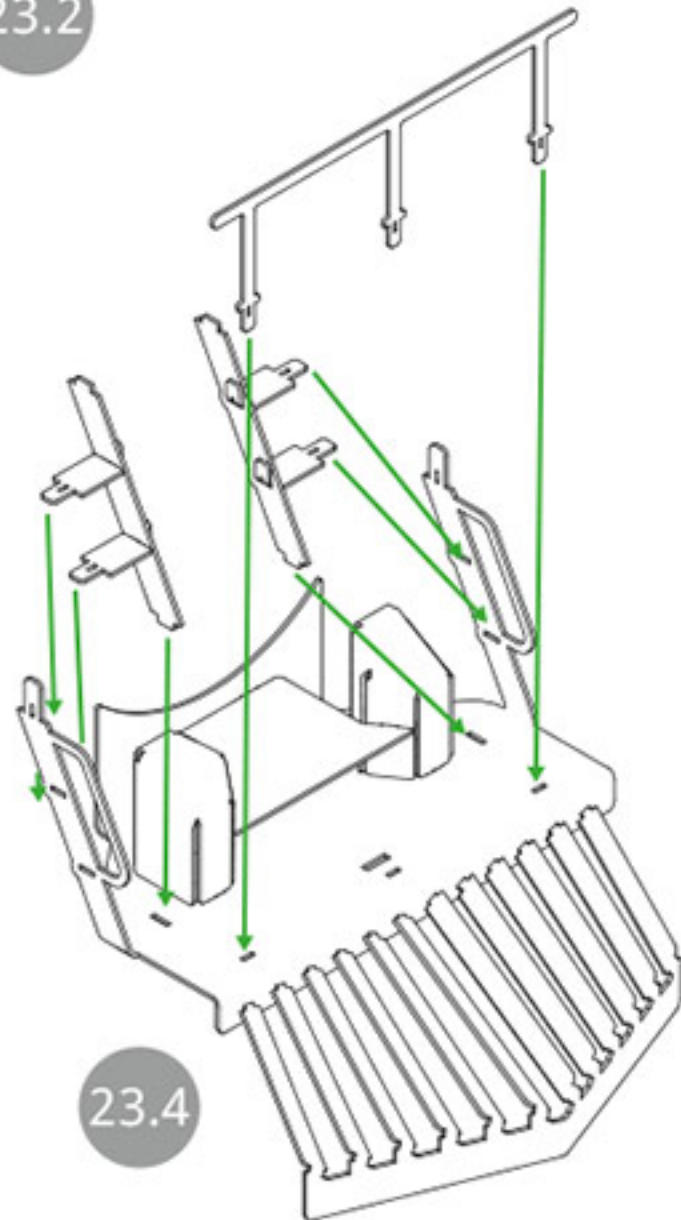

23.4

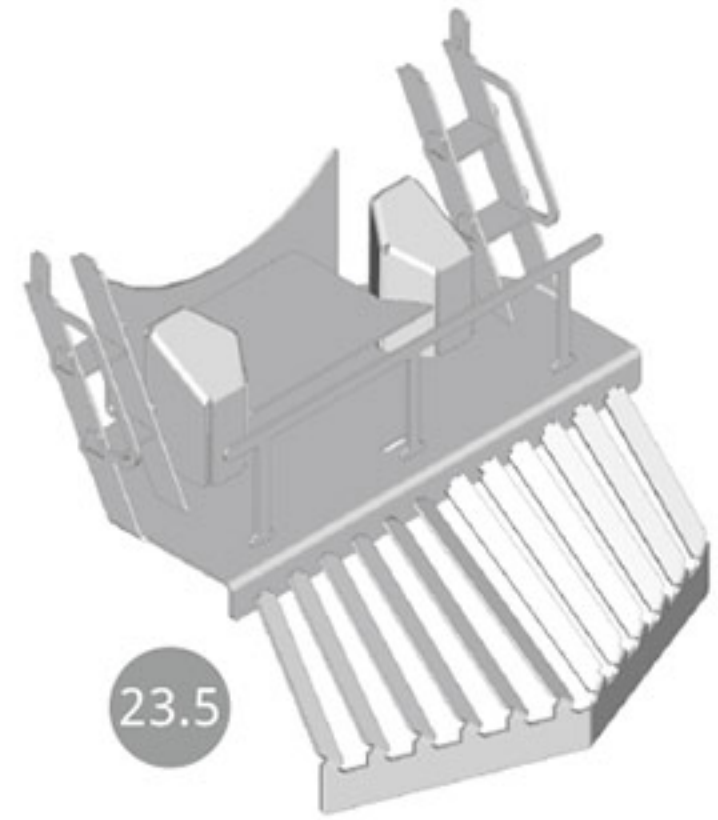

23.5

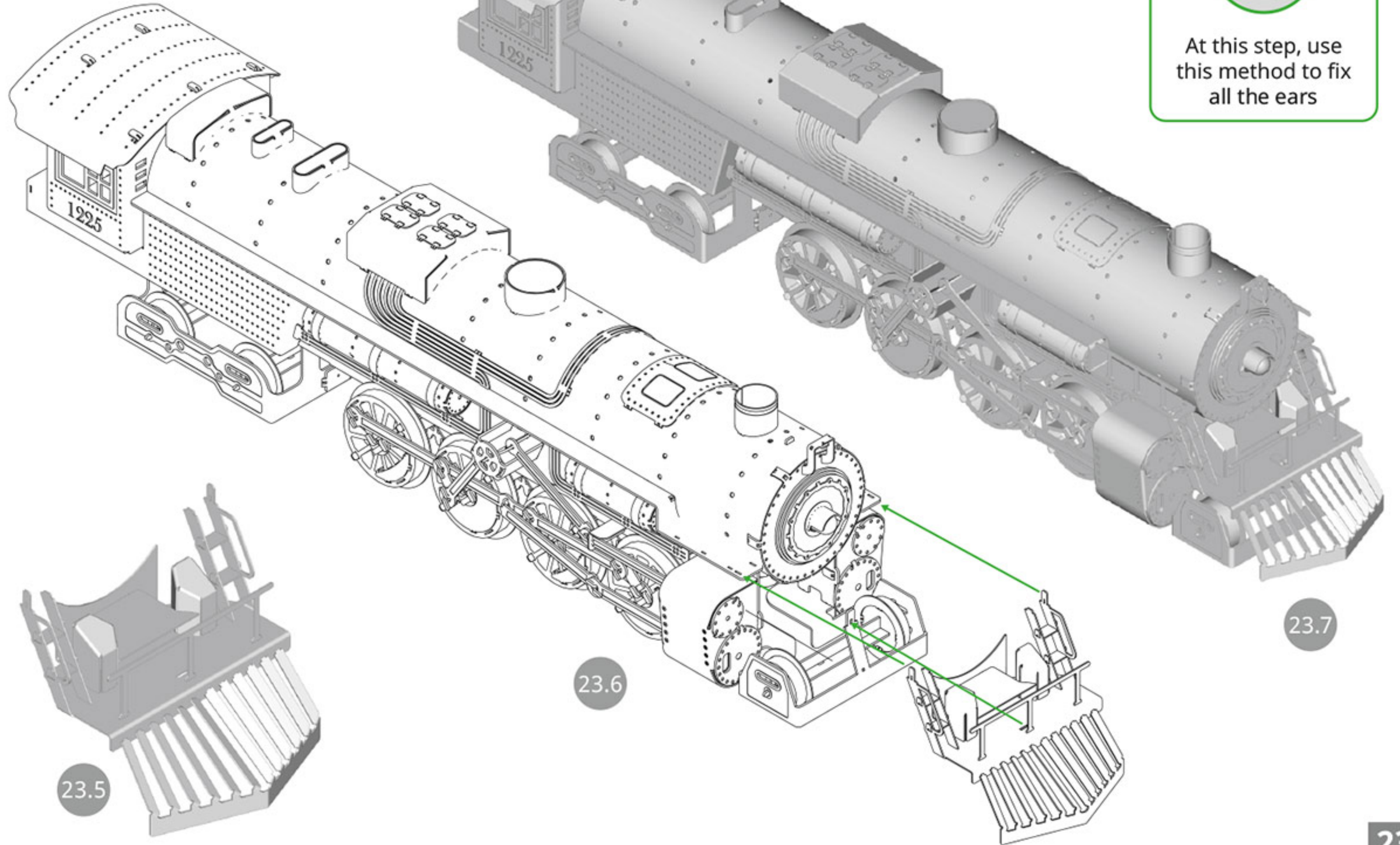

23.6

23.7



At this step, use this method to fix all the ears





#1

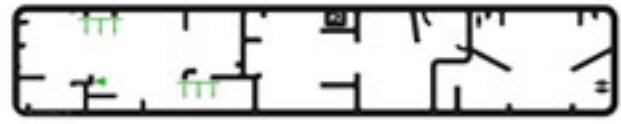

#2

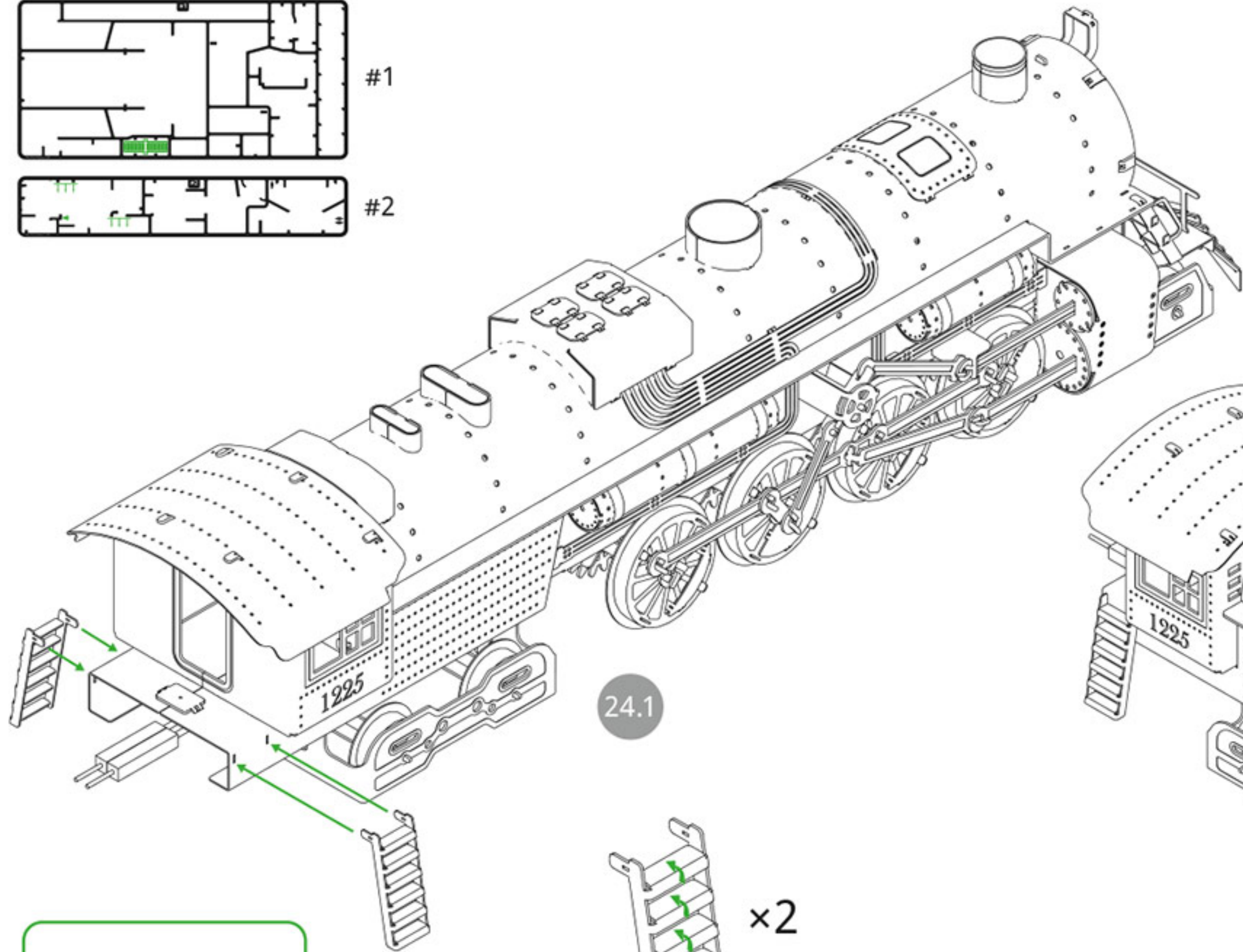

24.1

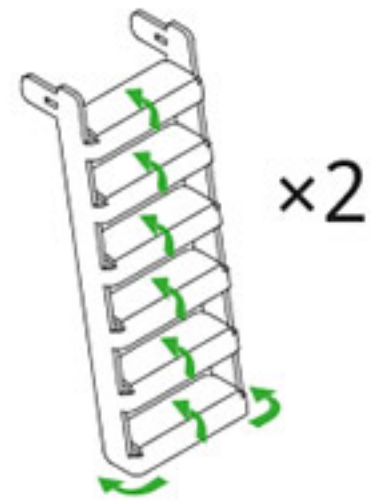

x2



At this step, use this method to fix all the ears

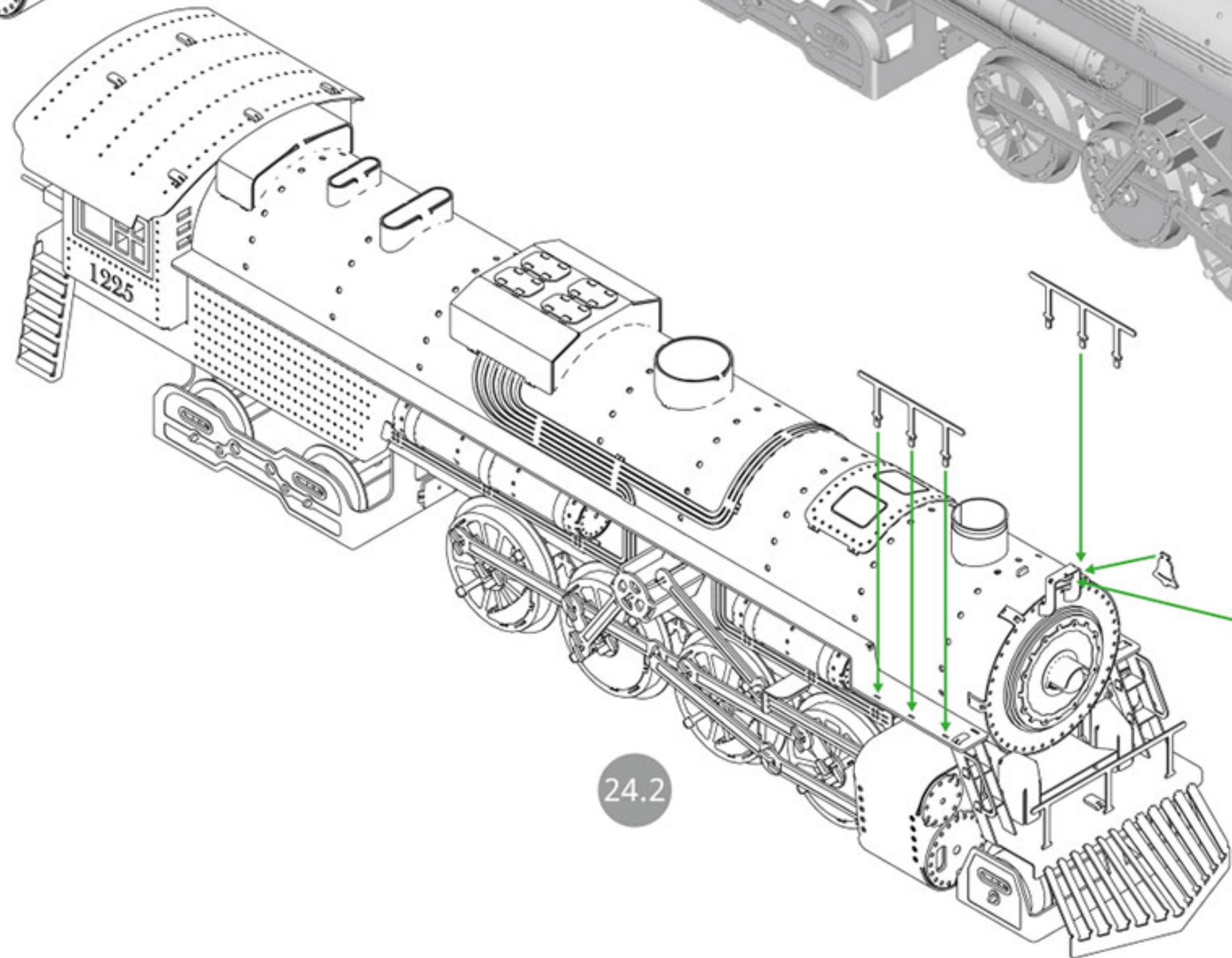

24.2

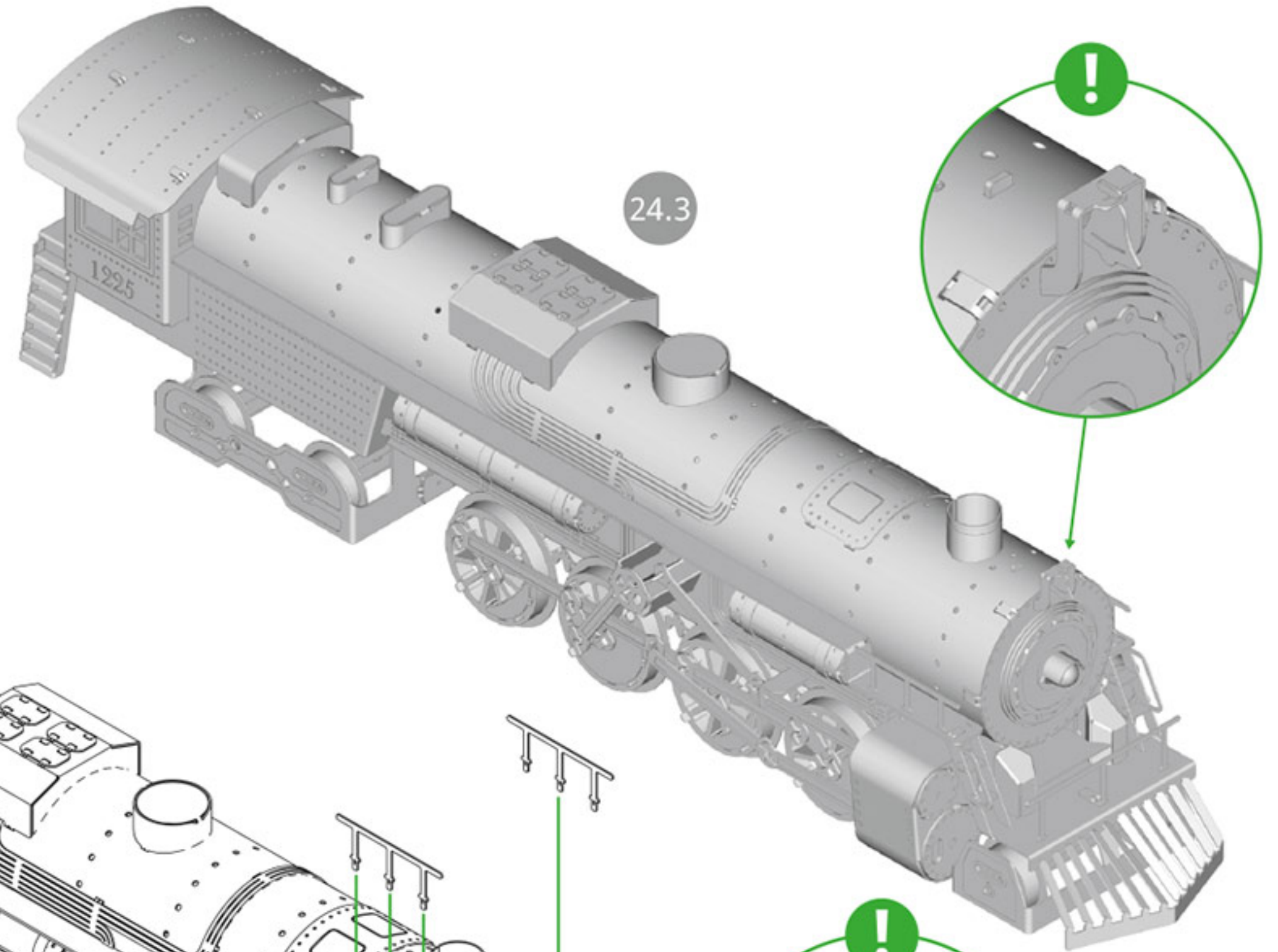
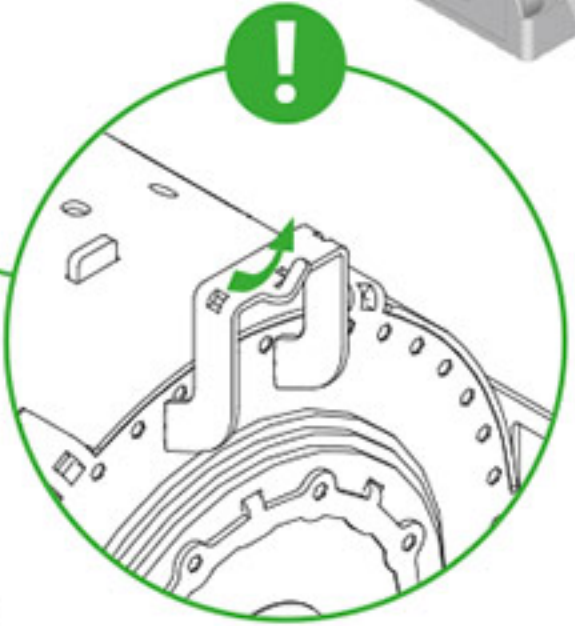

24.3



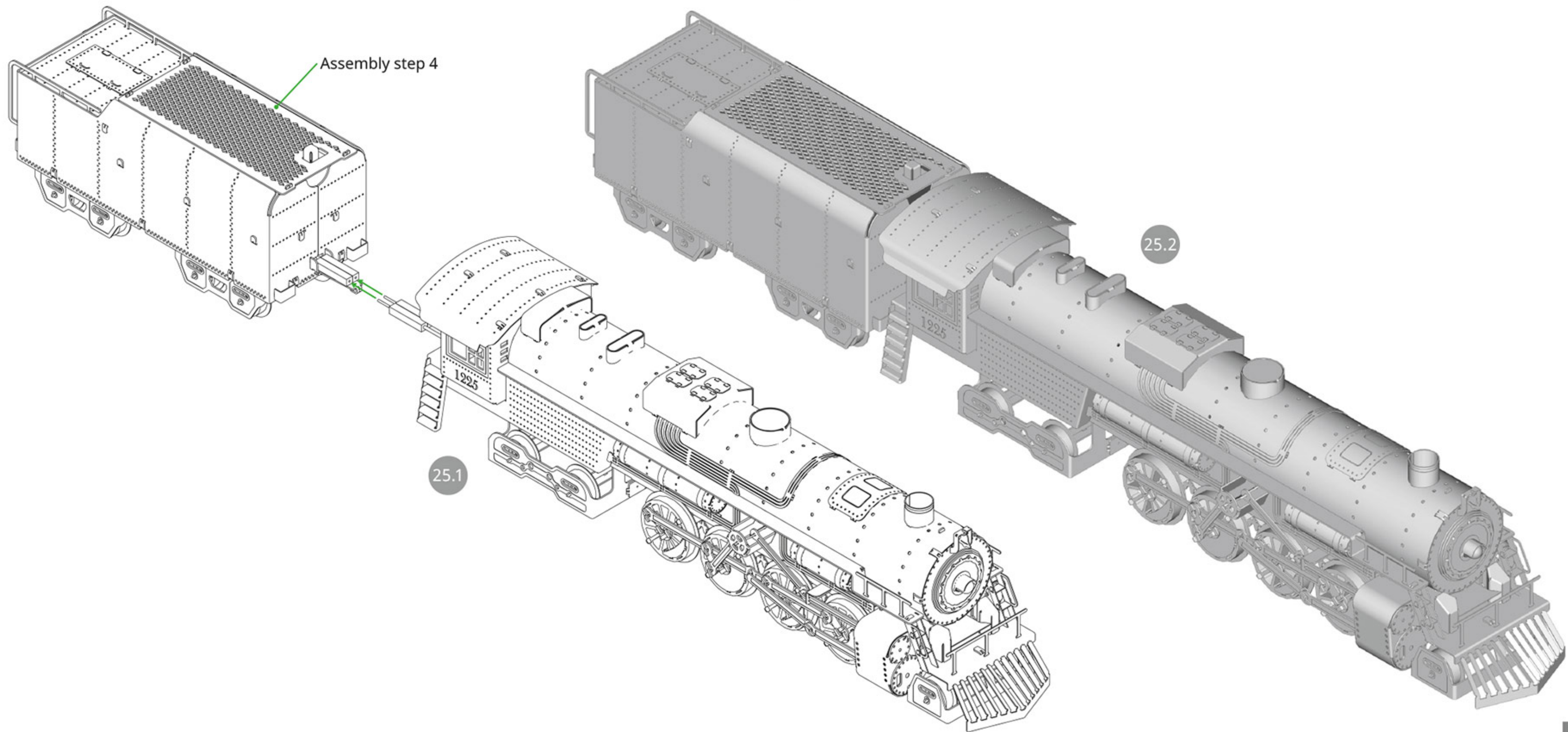

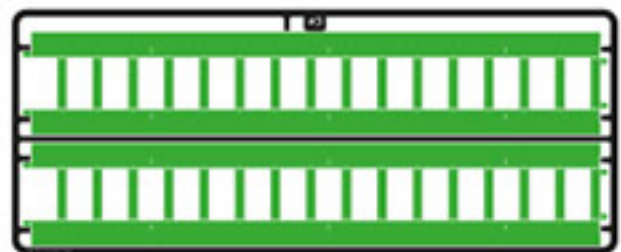

#3

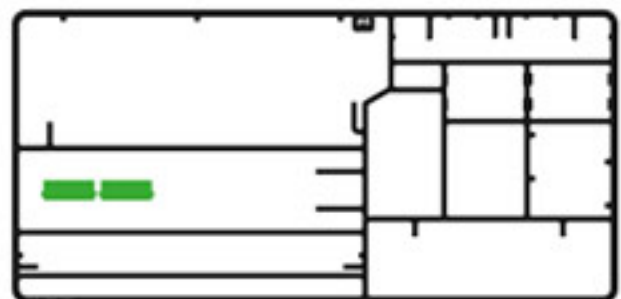

#4

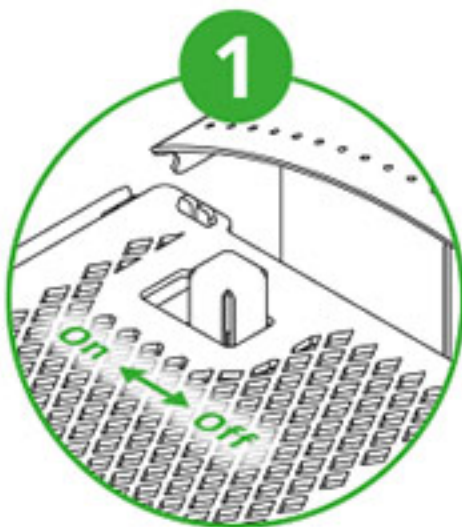

1

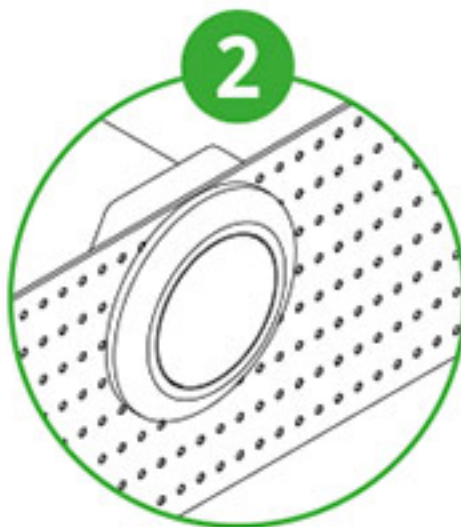

2

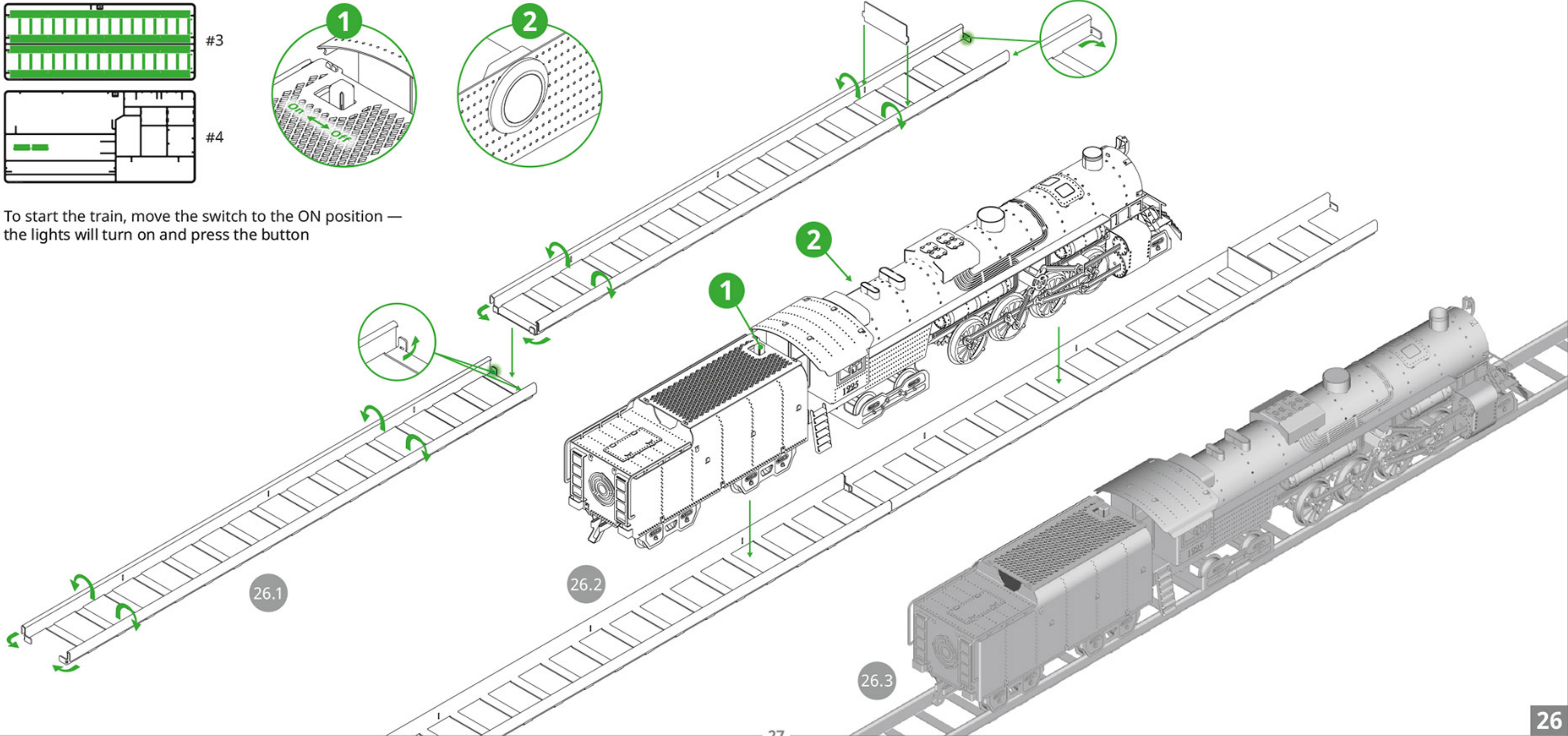

To start the train, move the switch to the ON position — the lights will turn on and press the button



Model name:

# POLAR STEEL

The train is waiting for you. "Polar Steel" is journeying to the North Pole. Board the train and race north over mountains and through boreal forests inhabited by timber wolves as well as rabbits, but this train never slows down. Build "Polar Steel" train with your own hands!

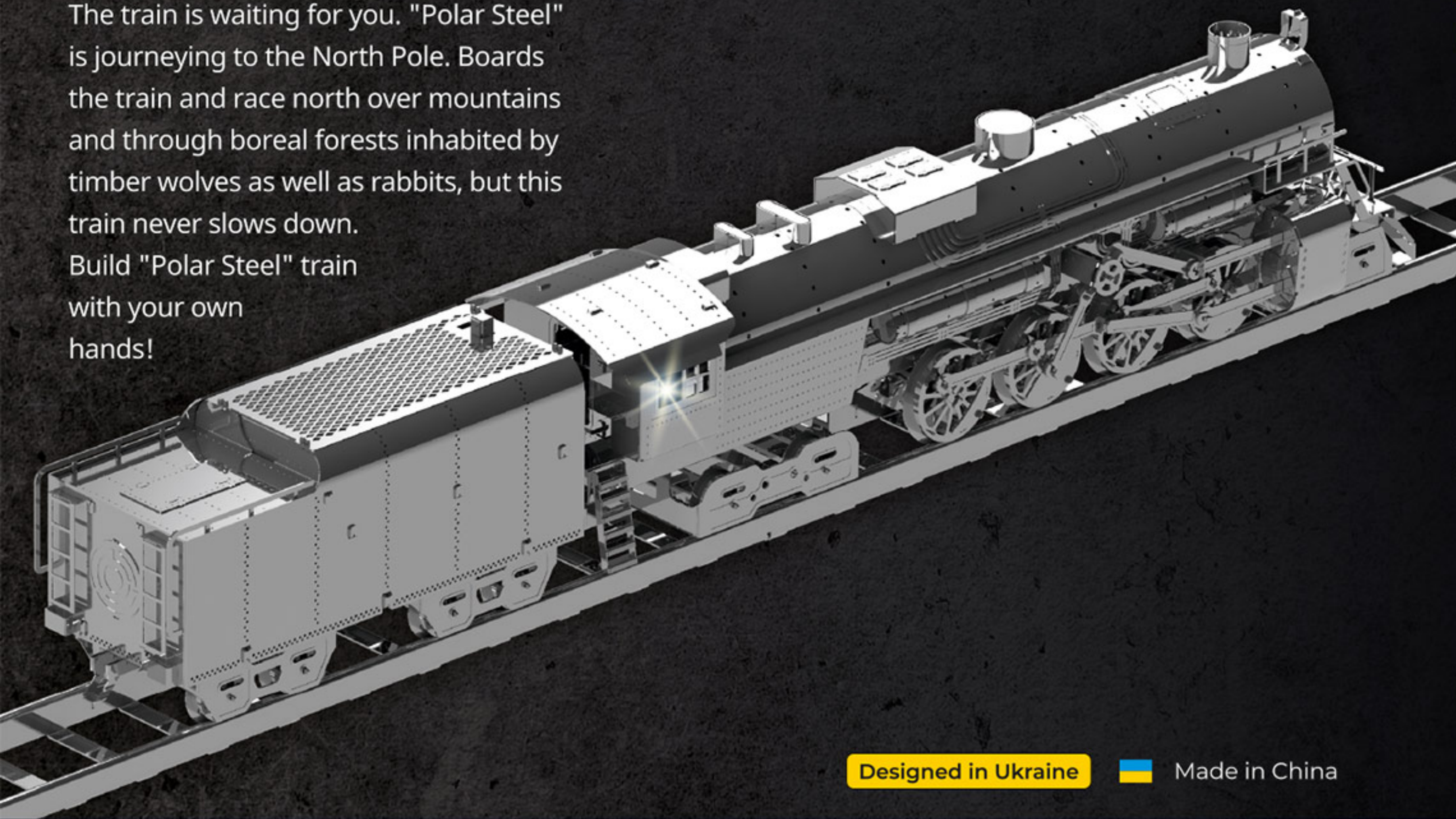

Product number: SKU052ST

Product material: Stainless steel

Number of metal sheets: 5 pcs

Finish product size: L14.37" x W2.44" x H1.97" (L36.5cm x W6.2cm x H5.1cm)

## ⚠ WARNING!

The product contains small and/or sharp parts. Not suitable for children under 3 years of age.

In order to avoid possible injury from sharp edges, please carefully discard the metal sheet after parts have been removed. This product is not a toy. Keep out of reach of children.

Conforms to CPSIA and CE standards. The product complies with the requirements of EN 71-1,2,3; ASTM F963, REACH, AS/NZS 8124, GB 6675



Difficulty level

Designed in Ukraine



Made in China

No expiration date

MODEL  
BUILDING  
KIT

@hobbadd.cn

霍布德



Collect the Best

**Includes:** steel sheets, gears, pliers, file, gloves, polishing cloth, user's guide, power switch, wires, LED light, electric motor and battery box (AA batteries are not included).

ALL RIGHTS RESERVED  
© Metal-Time Inc., USA

www.metal-time.com  
info@metal-time.com