



METAL[®]
TIME

THE GREAT BELL

3D Metal Mechanical Model Building Kit

Assembly instructions
Інструкція зі складання
Instrukcja montażu
Istruzioni di montaggio
Montageanleitung
Instructions de montage
Instrucciones de montaje

Instruções de montagem
Инструкция по сборке
装配说明书
조립 설명서
組立説明書

تعليمات التجميع
הוראות הרכה

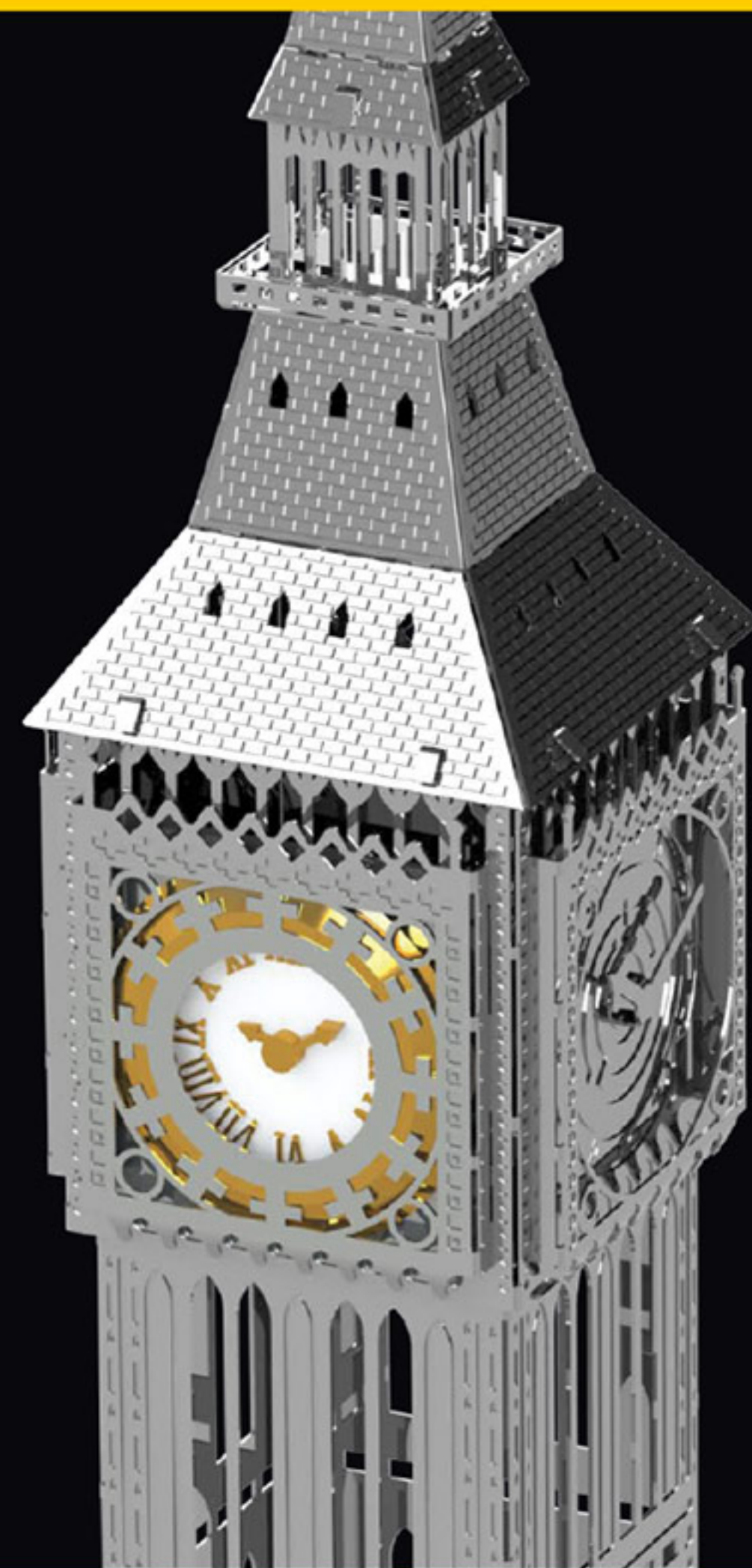

Collect the Best

35 PIECES

3 hours

Interior décor / Clock mechanism
Candle place

AGES
14+

WARNING! PLEASE READ THESE INSTRUCTIONS CAREFULLY BEFORE ASSEMBLY AND USE

When assembling the model, don't rush, avoid pointing details at yours or anyone else's face. If one of the parts has a sharp edge, please file it down. Use pliers and additional tools to assemble the model. Each kit contains a cloth for wiping and polishing the model once it's assembled. If needed, you may choose to apply a small amount of siliconbased grease to the spring and the mechanism; however, this is not a requirement for the mechanism to function properly. The mechanism will perform at its best in the absence of excessive friction or excessive play of its parts

WARNING! Product contains small parts and sharp parts. Not suitable for children under 3 years of age

SYMBOLS



Bend the eyelet 90°



Twist the eyelet 45°

Model for collectors, suitable for children 14+

MODEL PARTS AND ASSEMBLY TOOLS

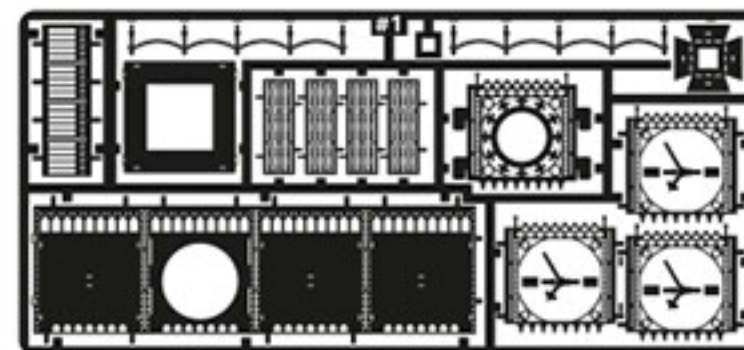

#1

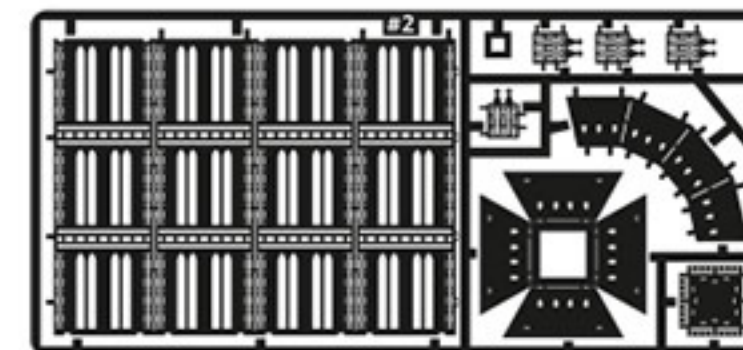

#2

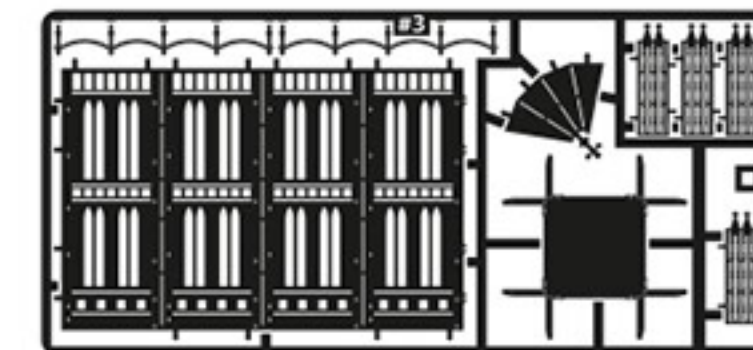

#3

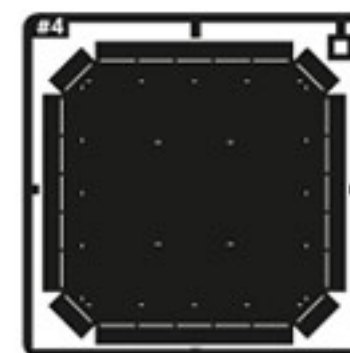

#4



Clock

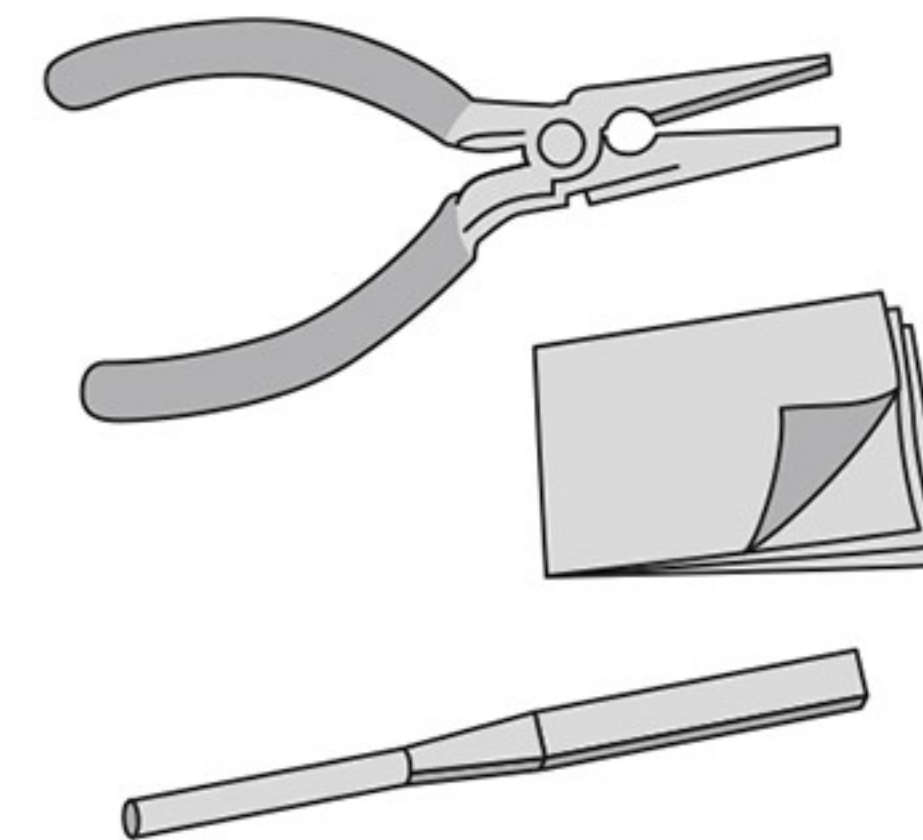

Tools

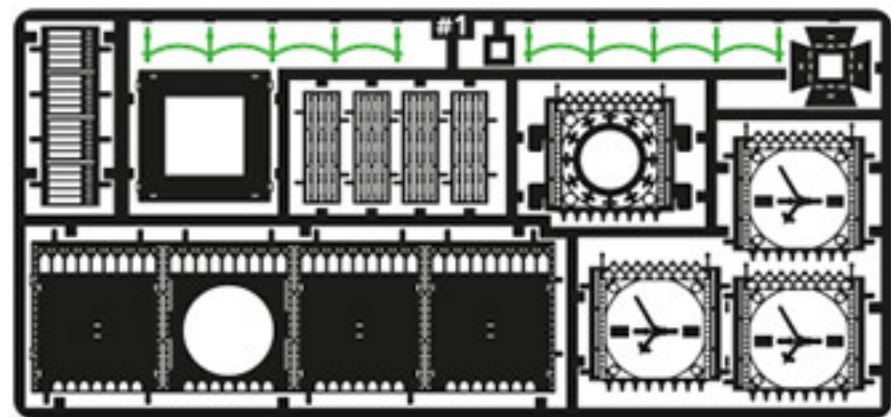

#1

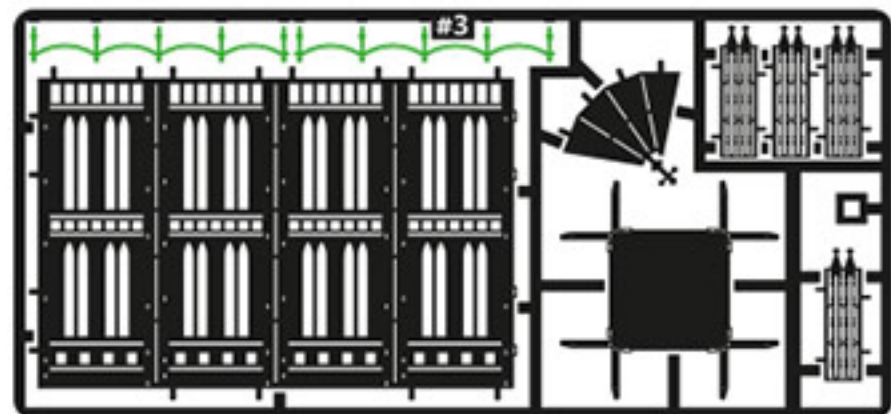

#3

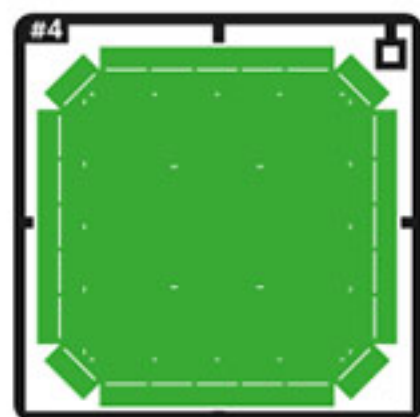

#4

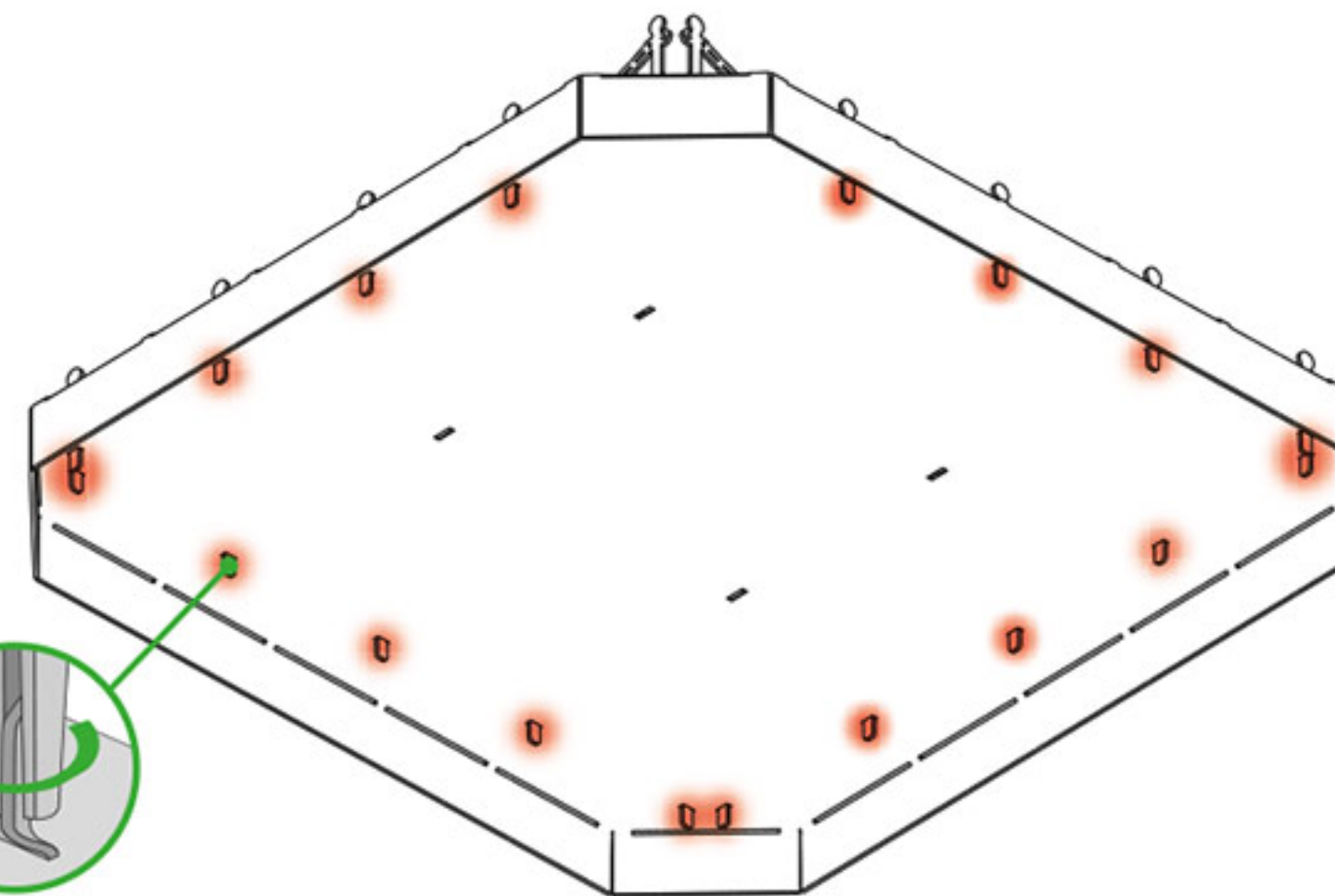
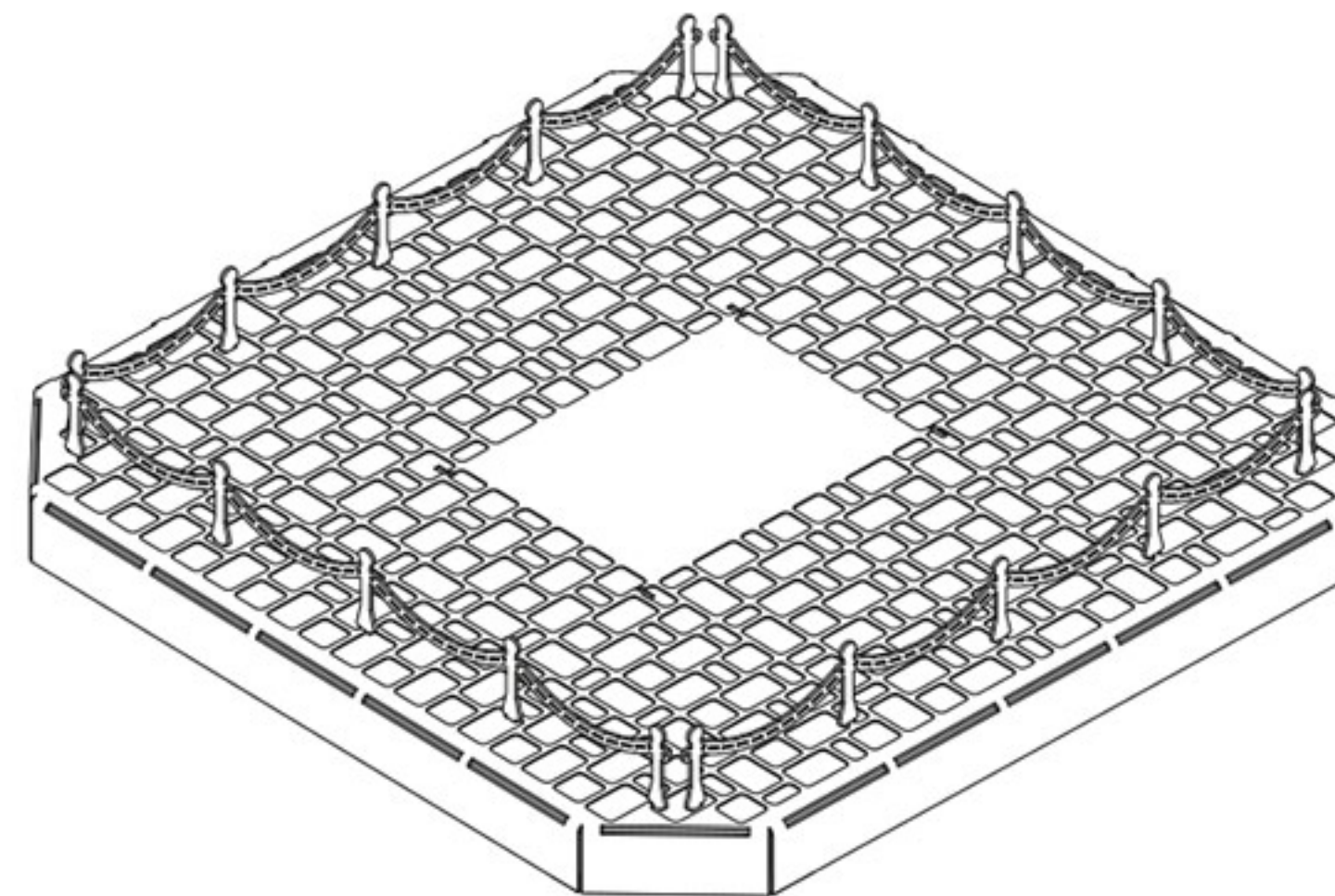
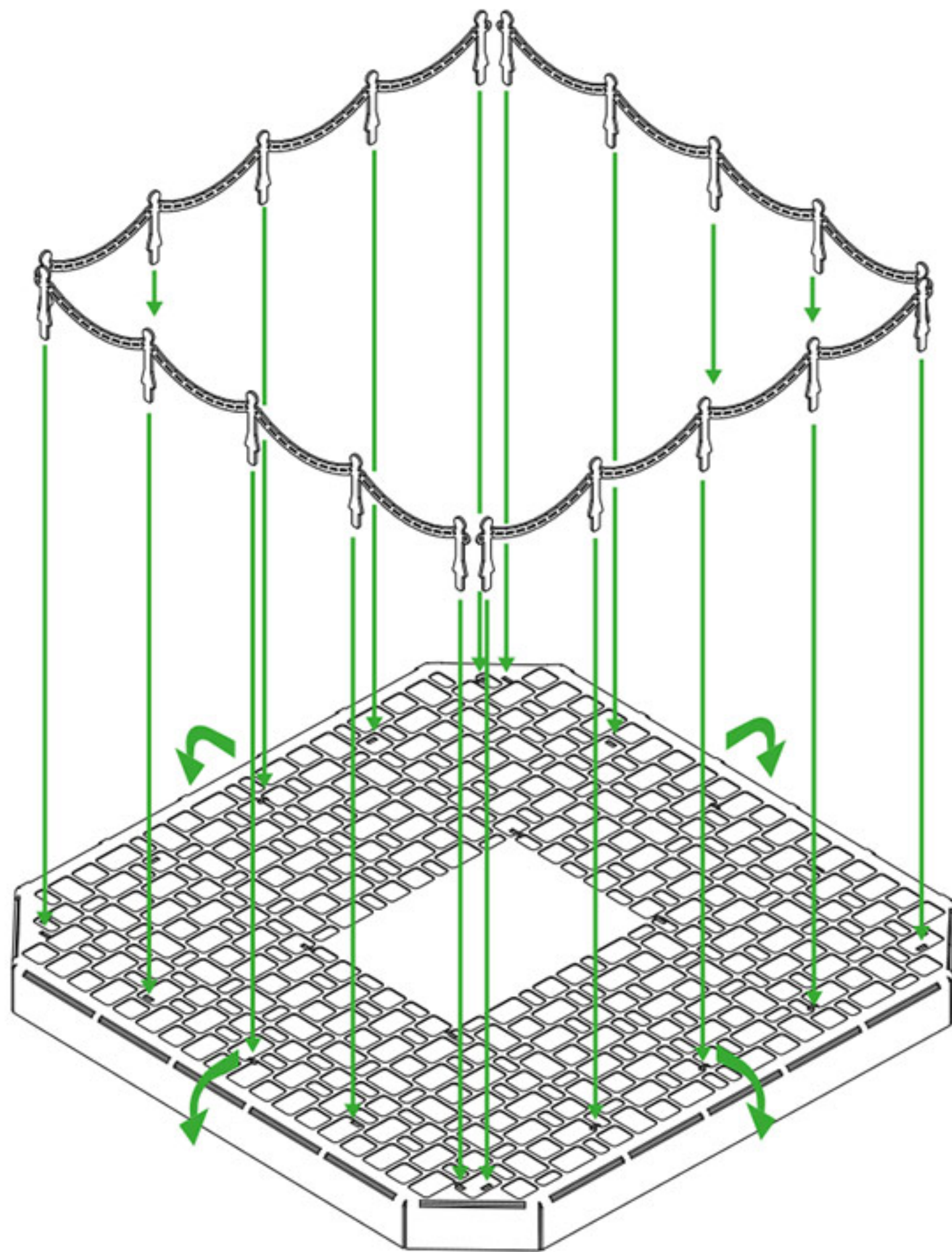

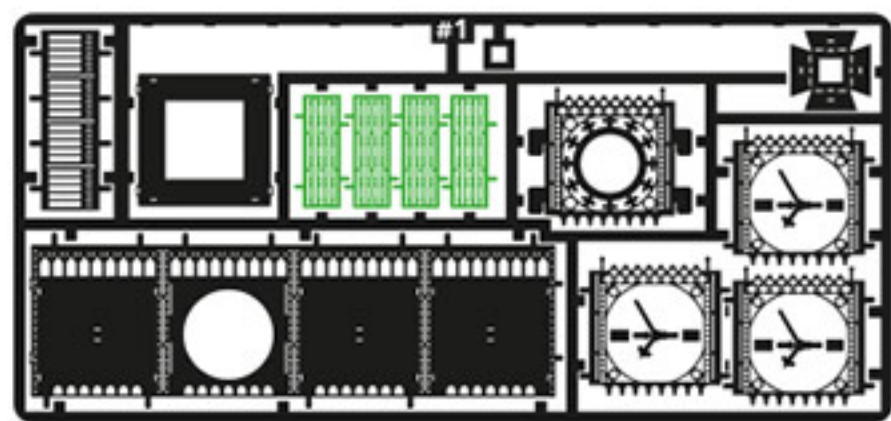

#1

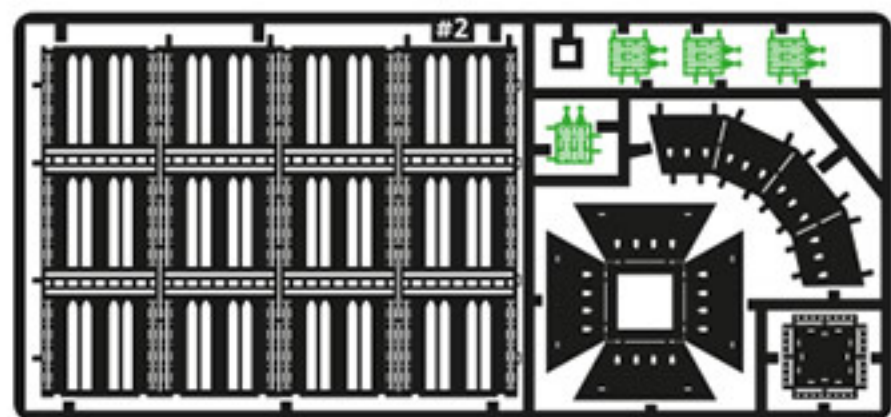

#2

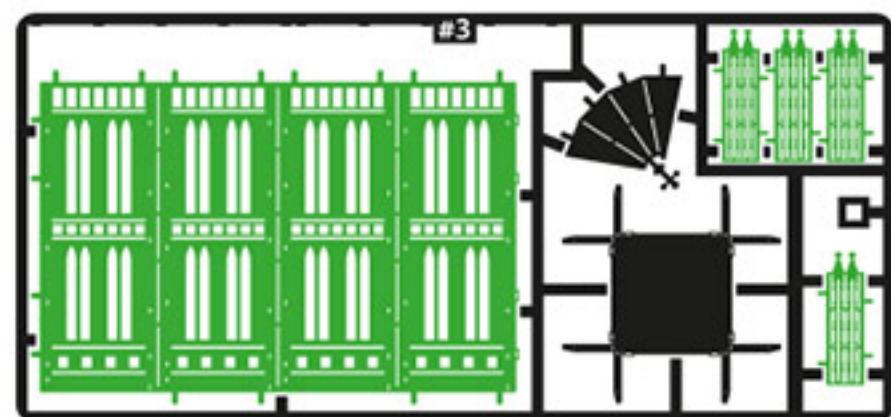

#3

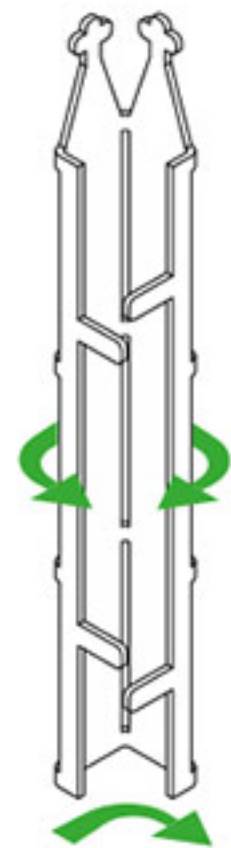

x4

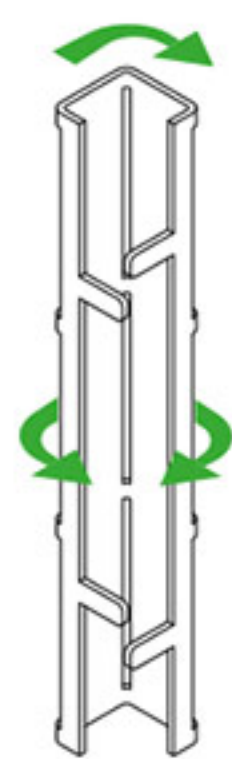

x4

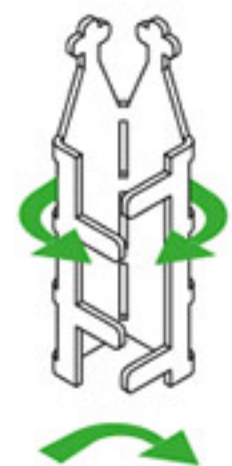

x4

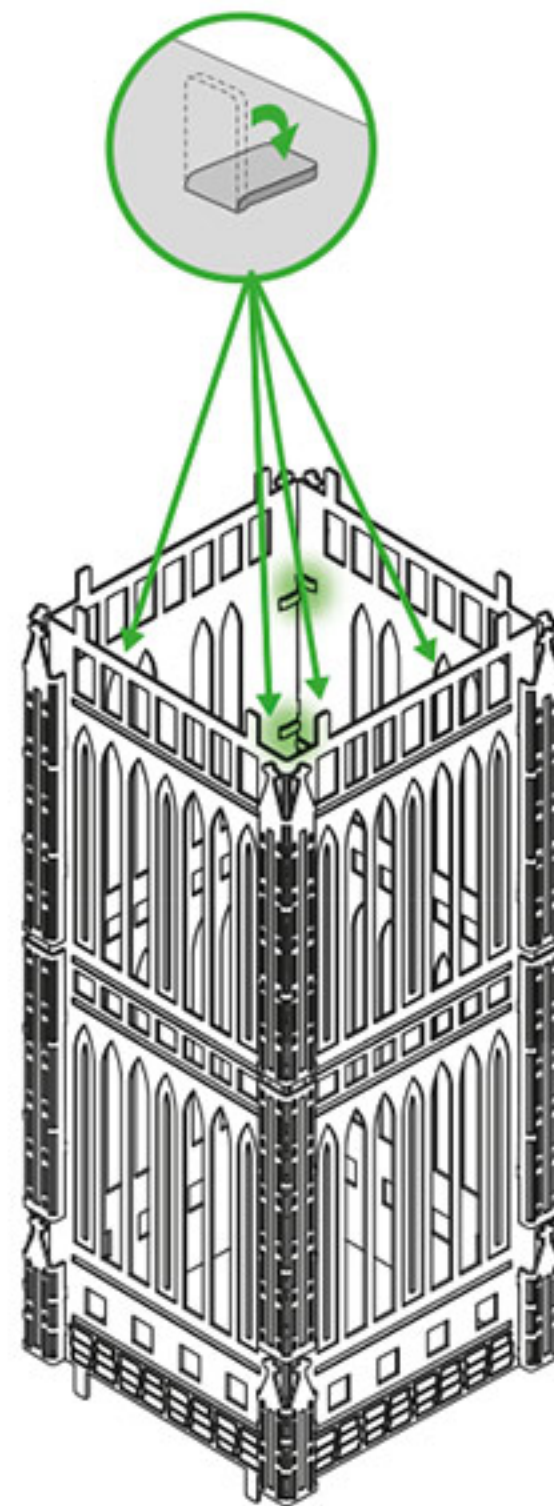
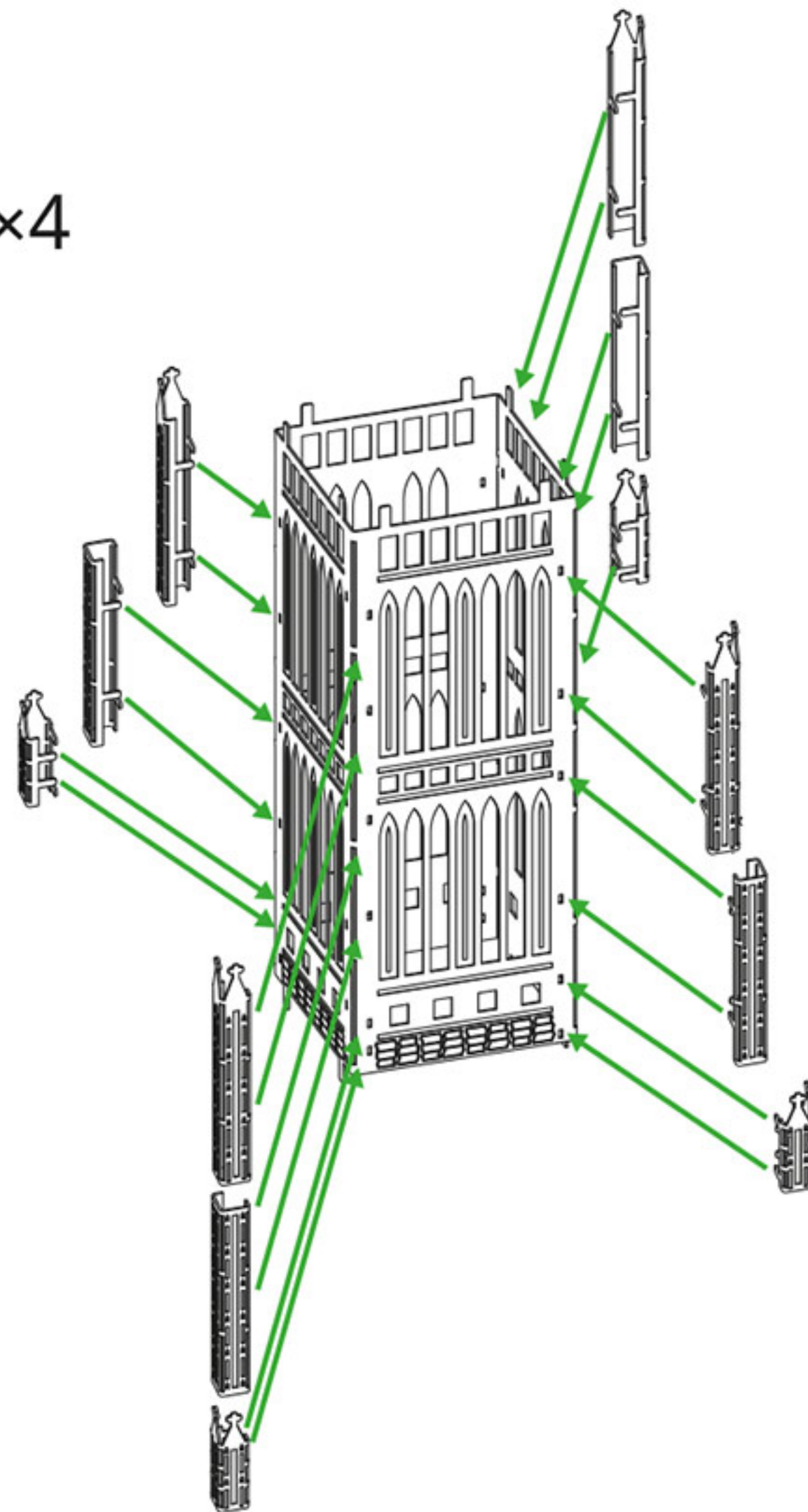
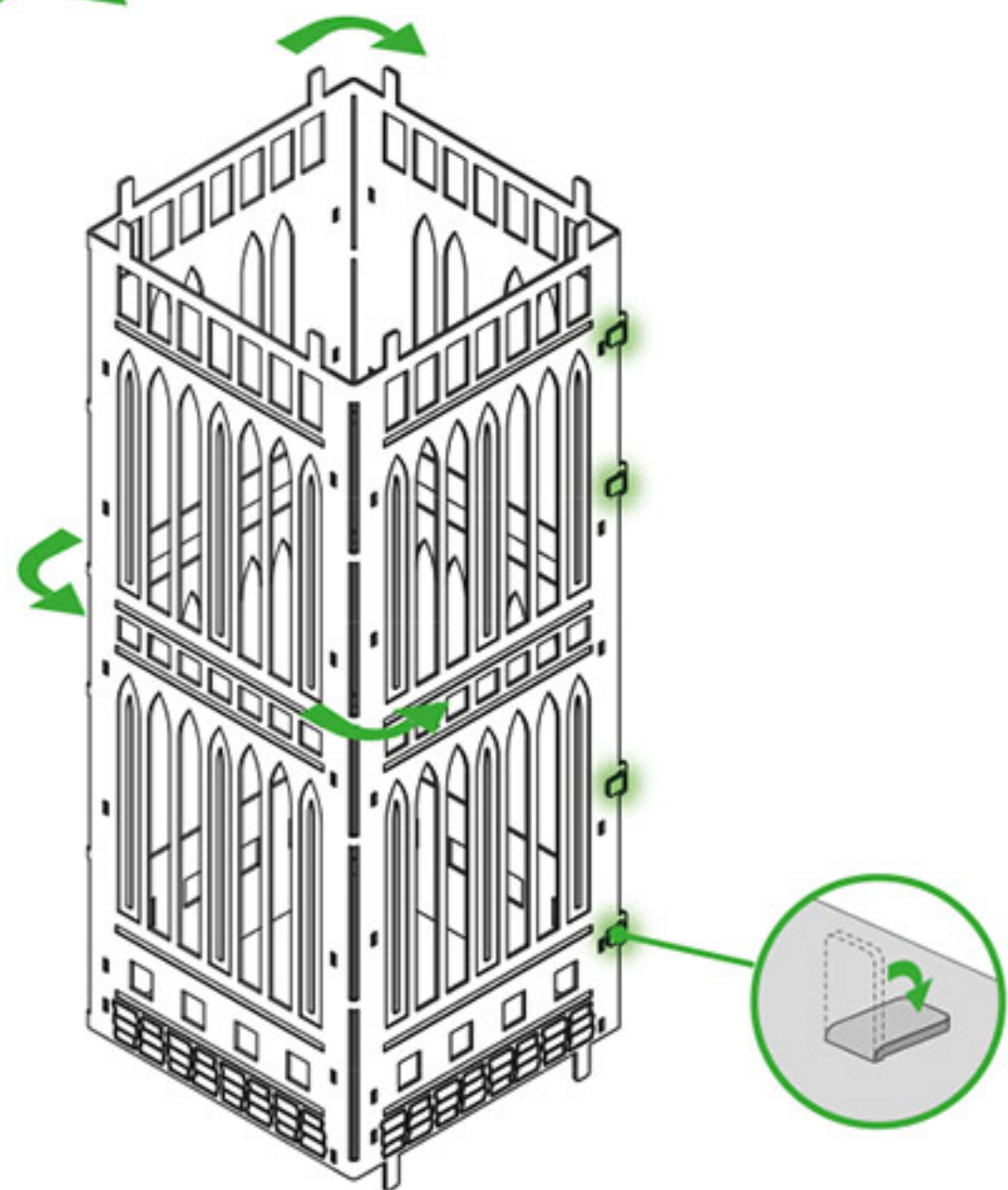

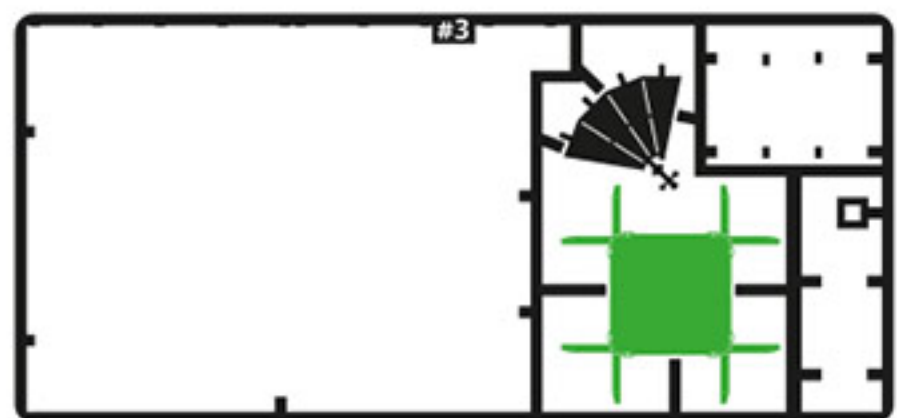

#3

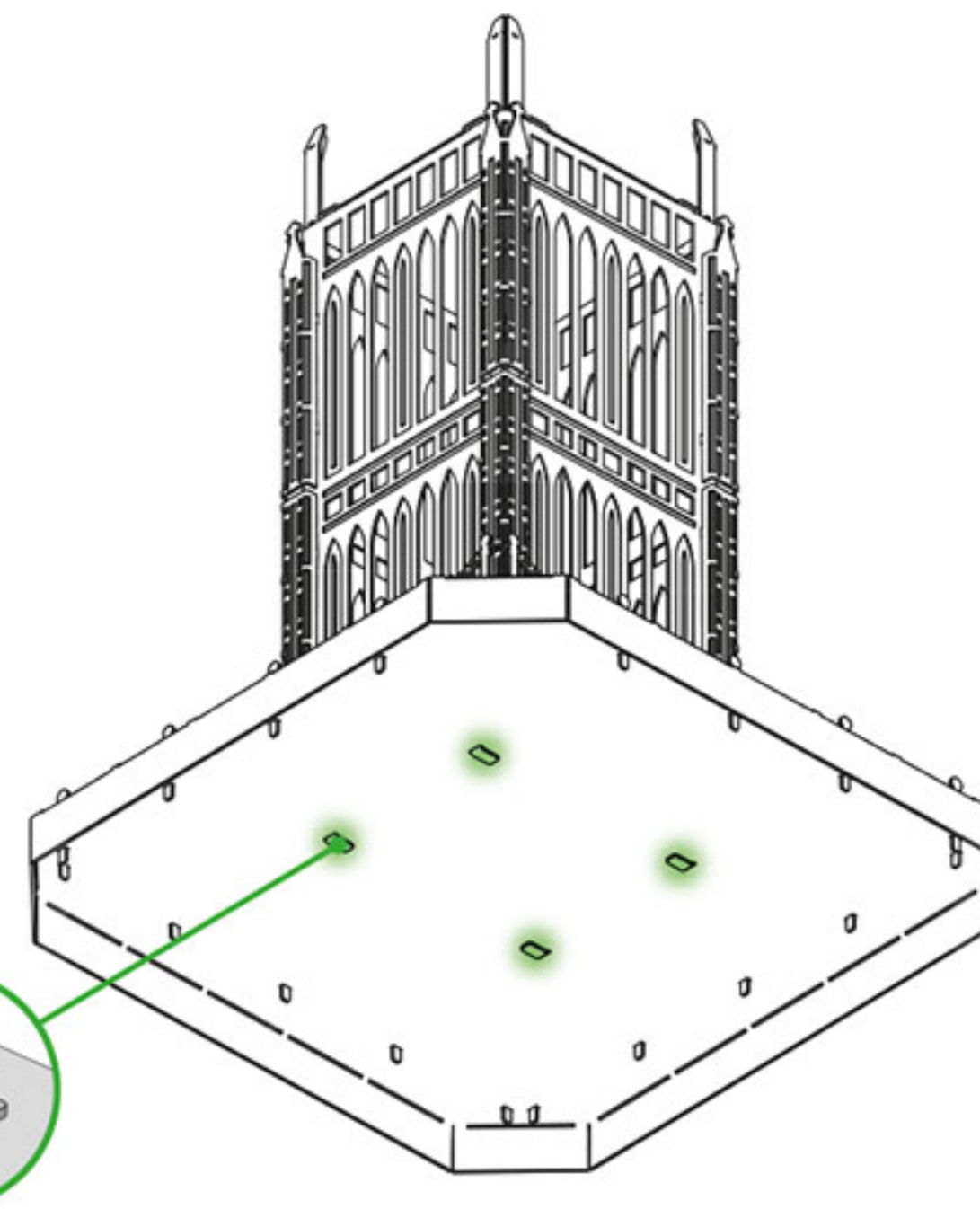
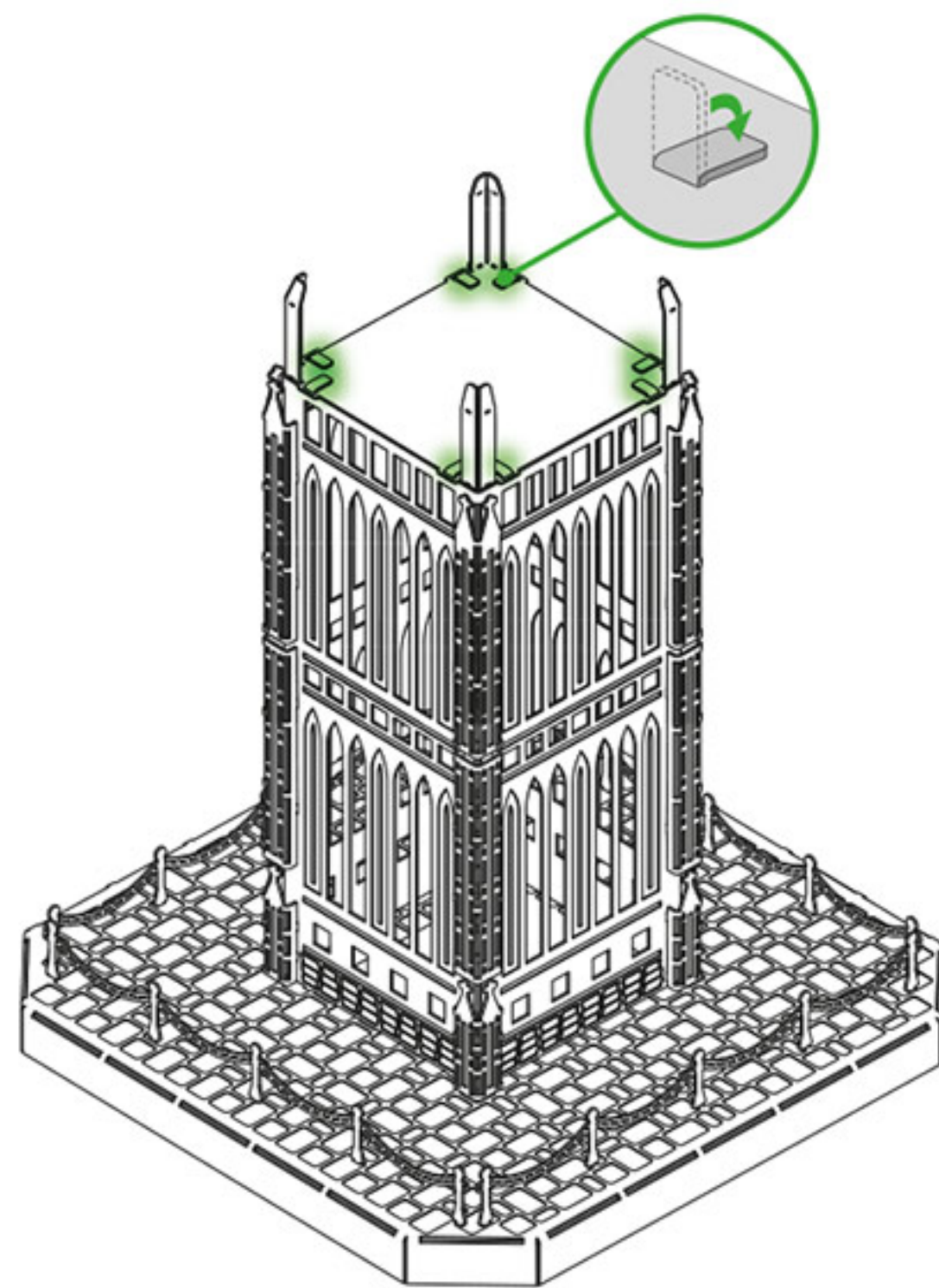
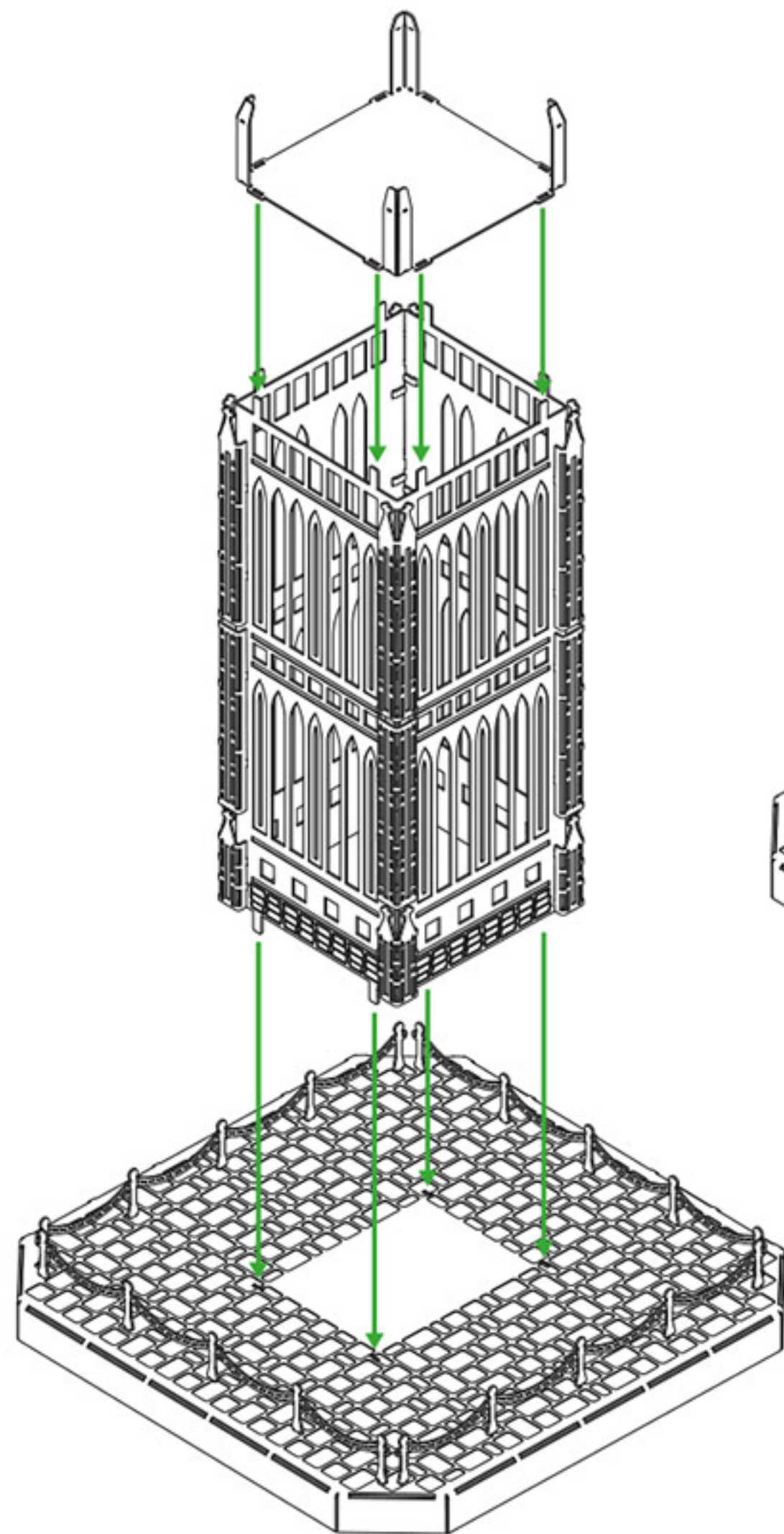
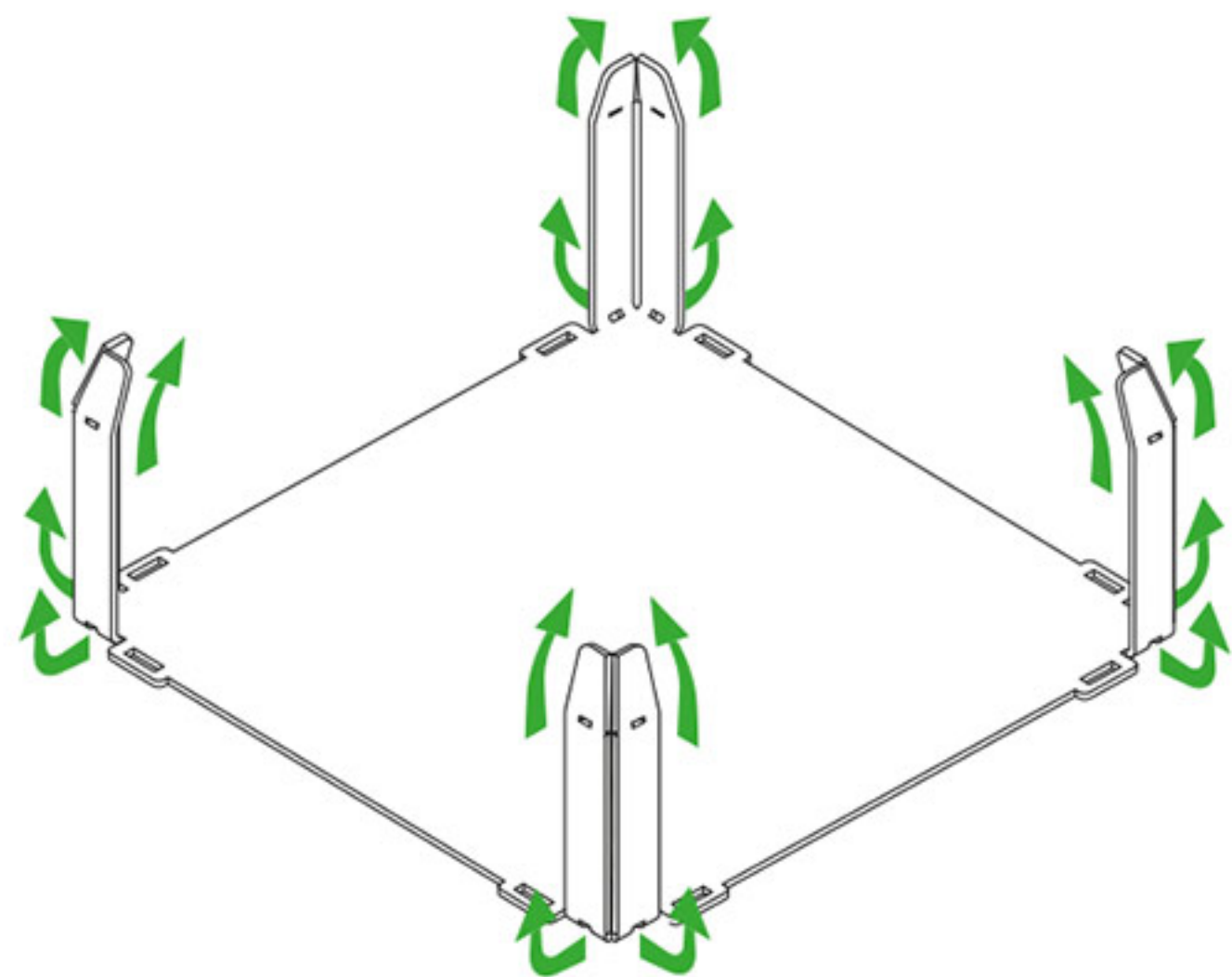

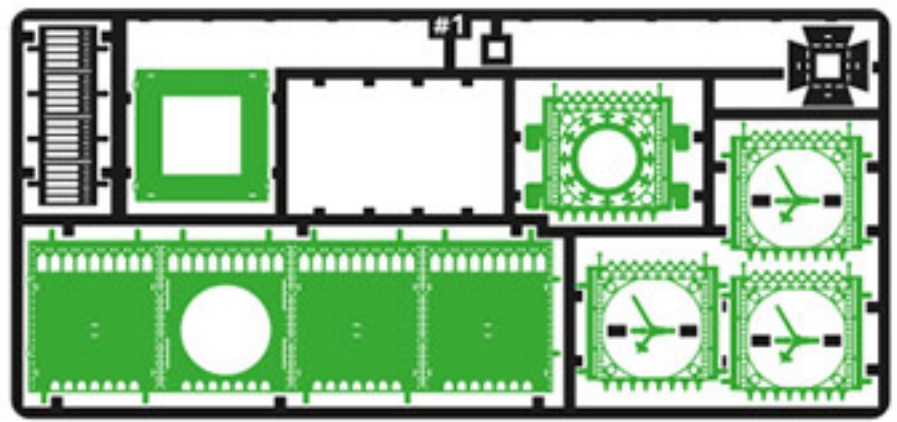

#1

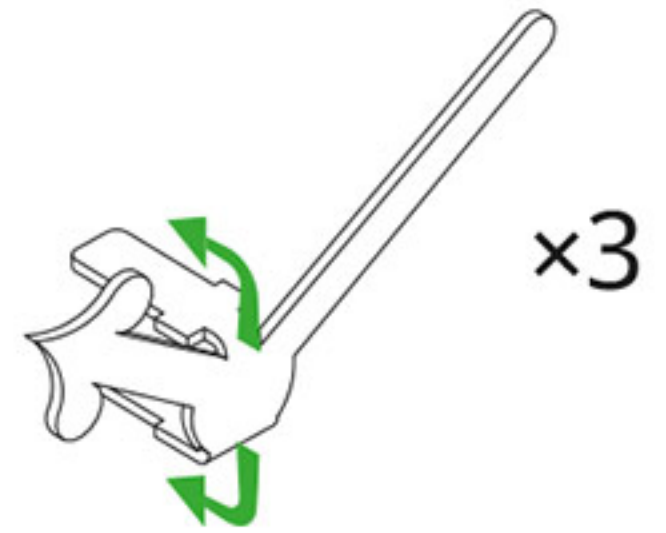

x3

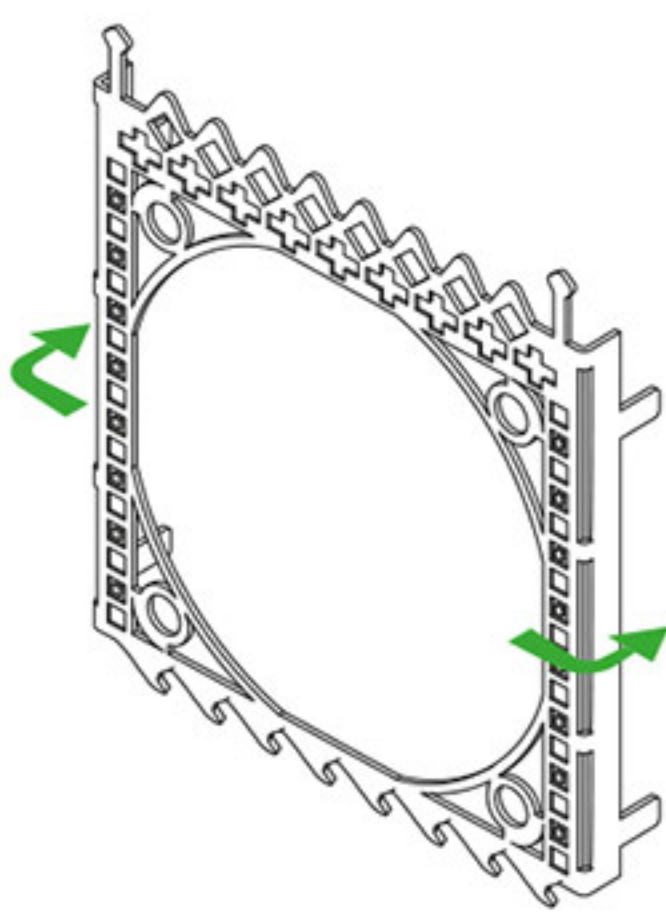
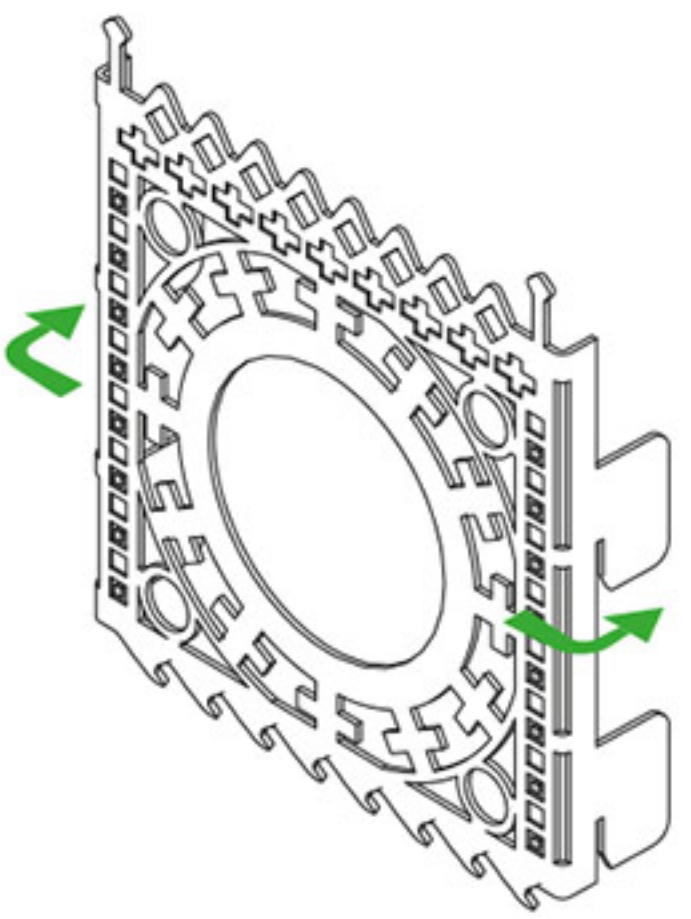

x3

Clock

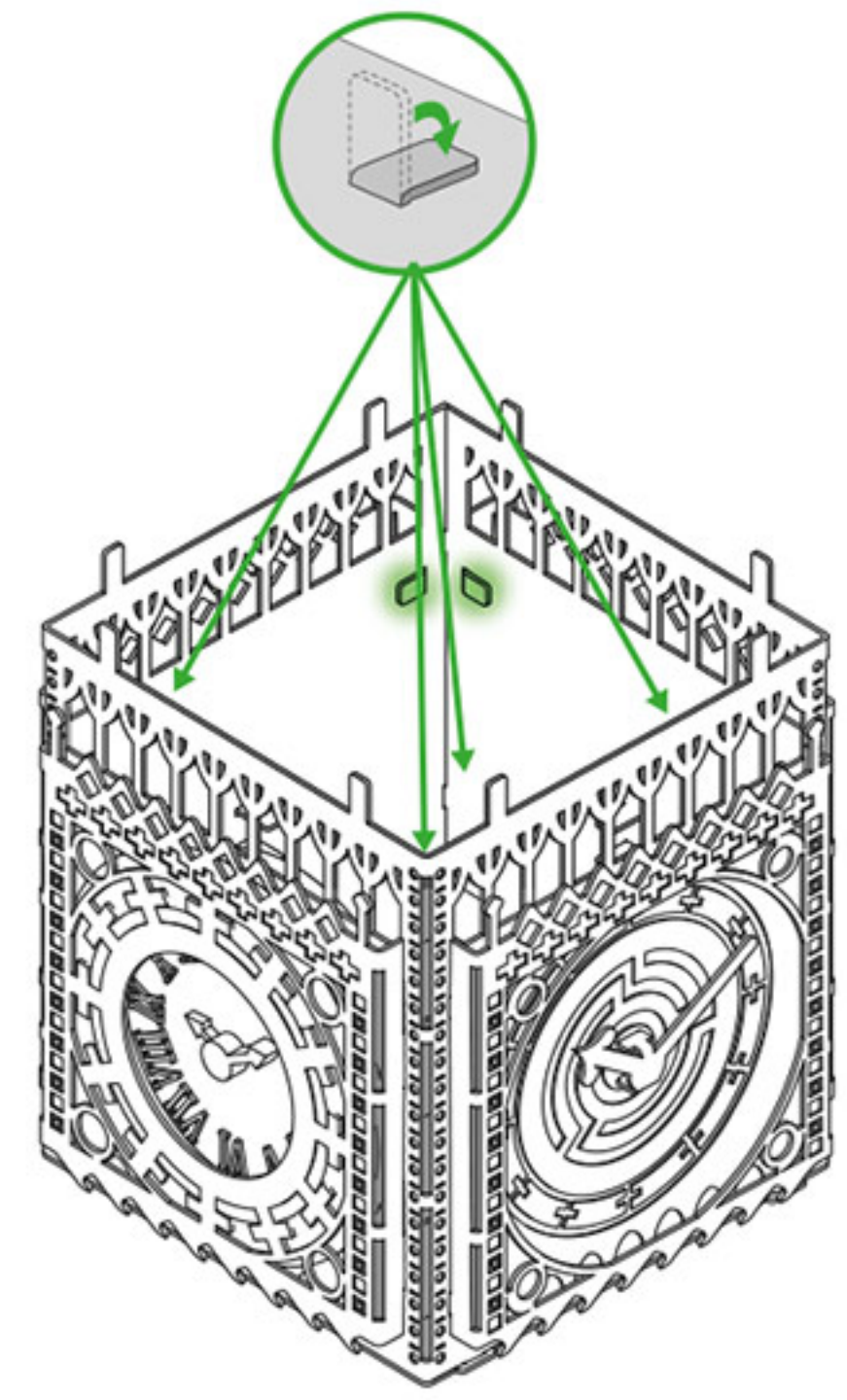
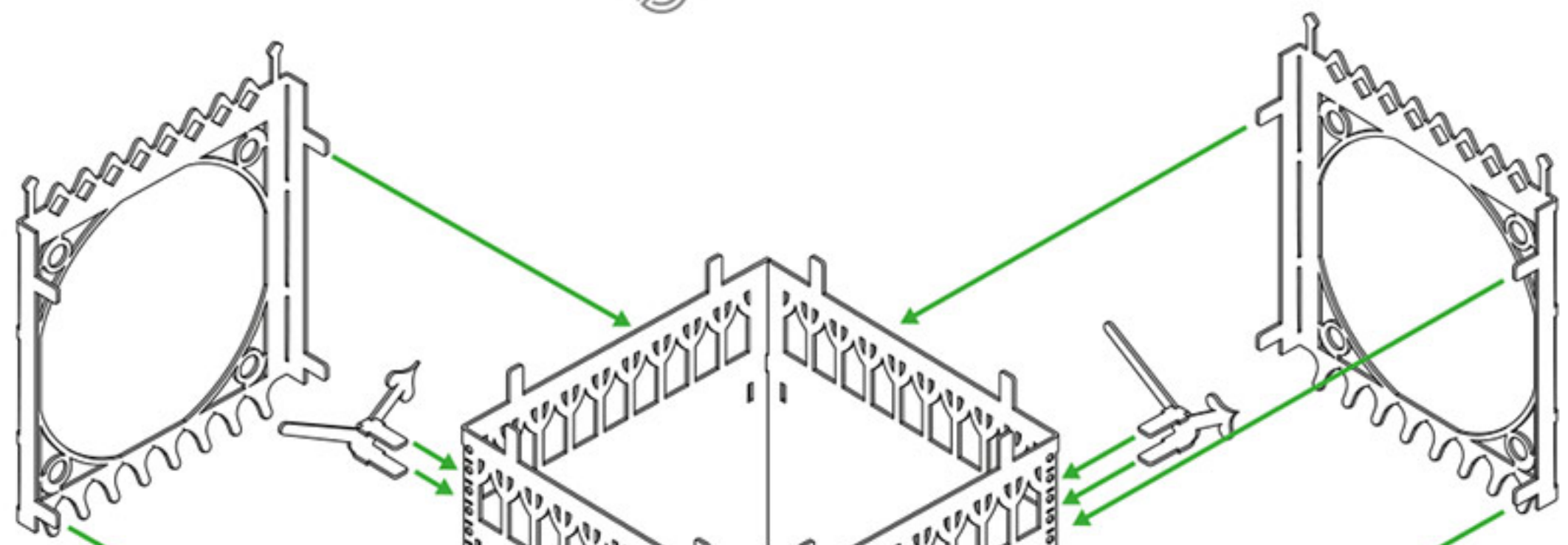
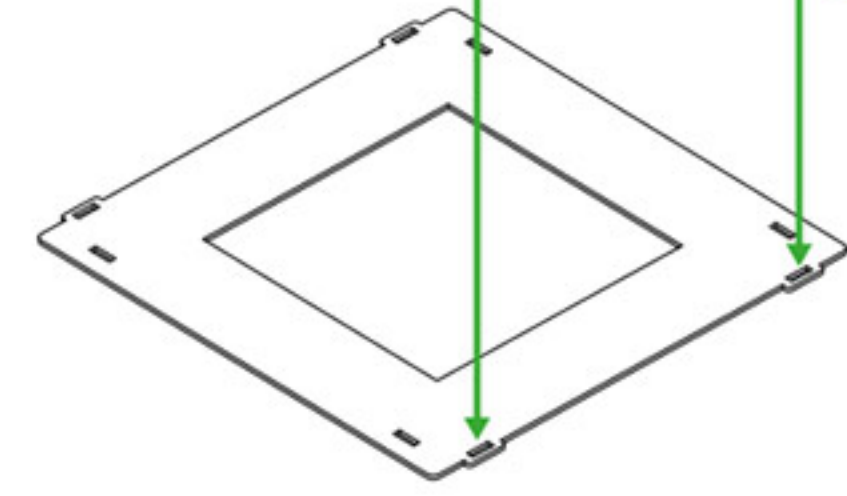
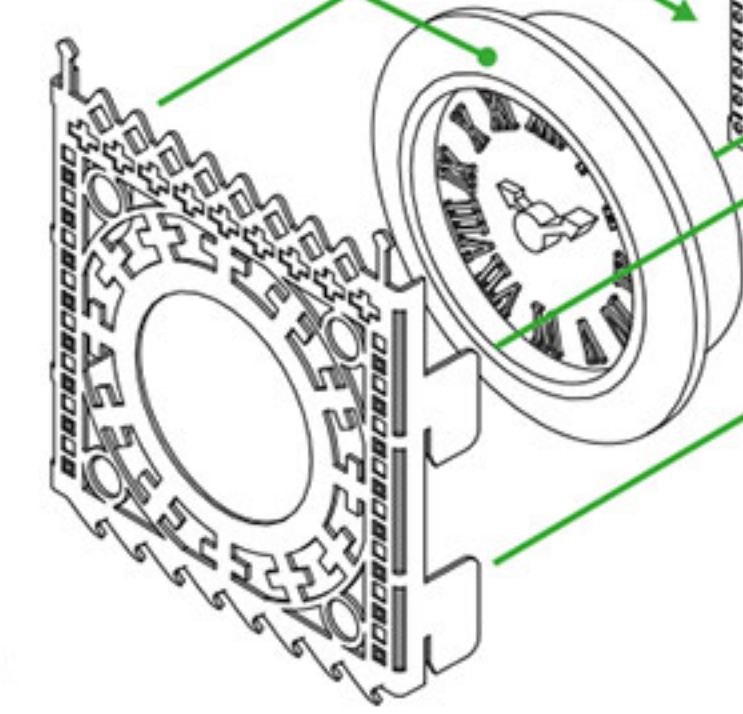

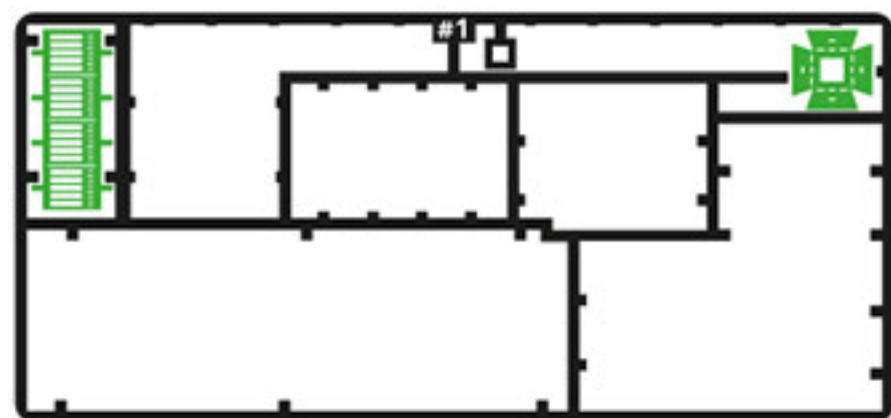

#1

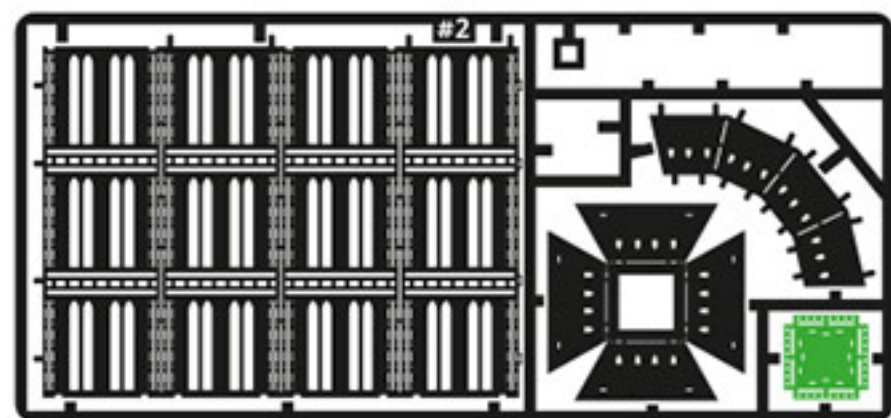

#2

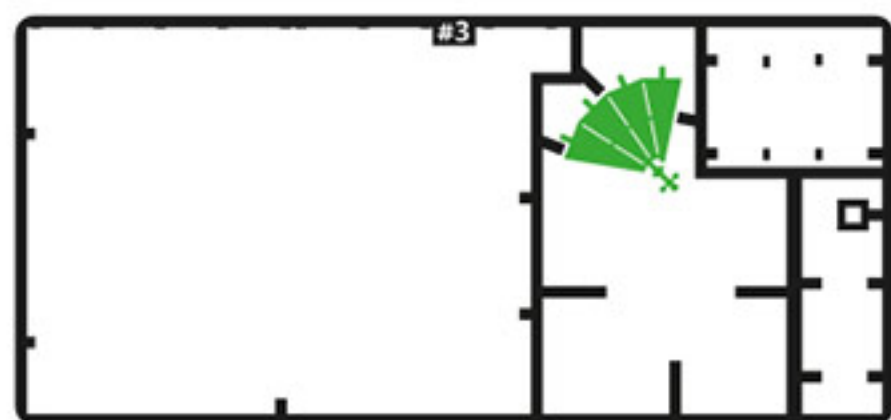

#3

 At this step, use this method to fix all unmarked ears

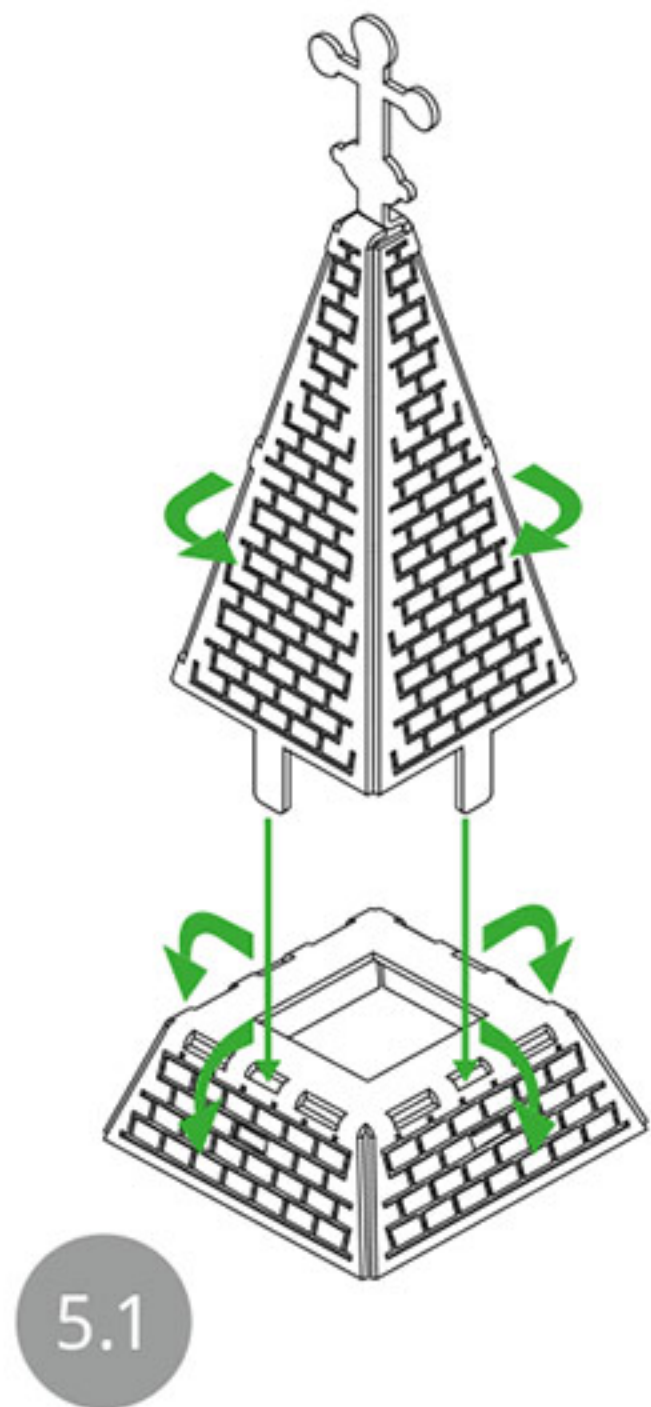

5.1

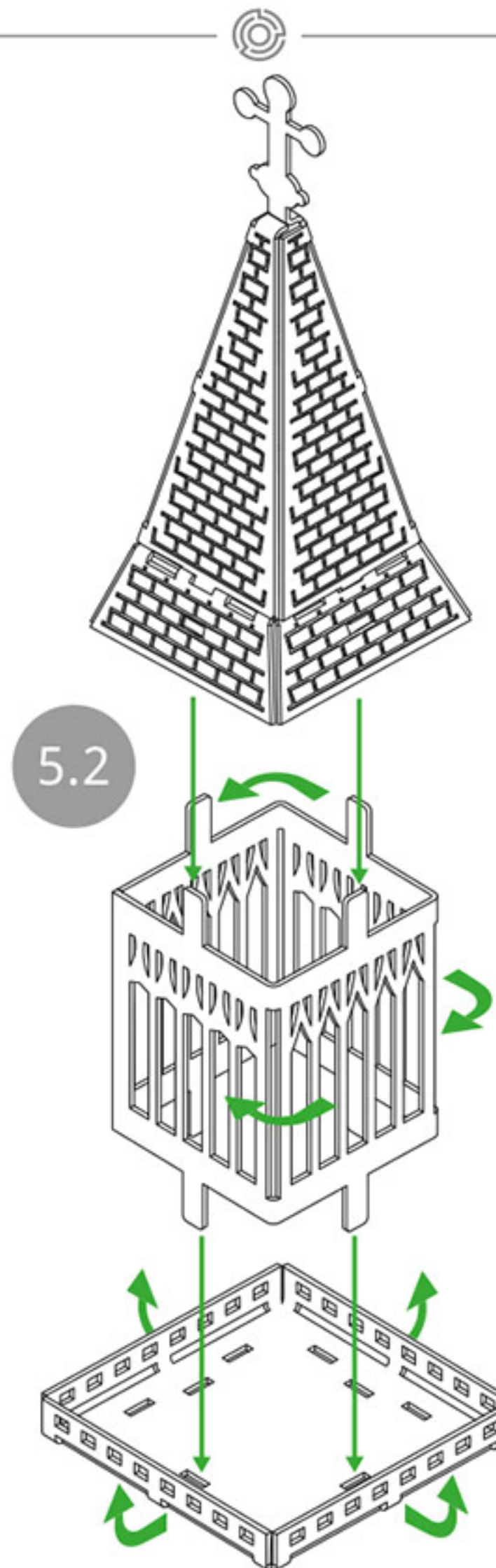

5.2

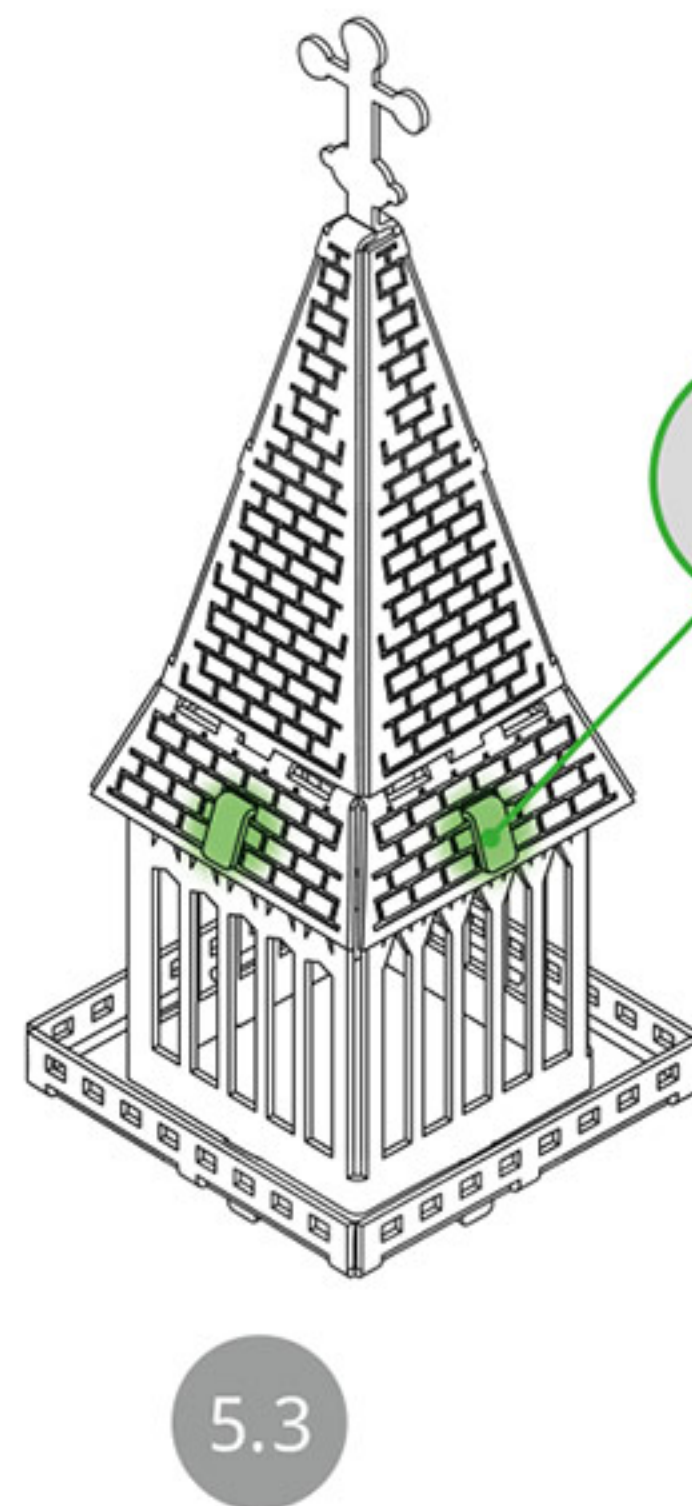

5.3

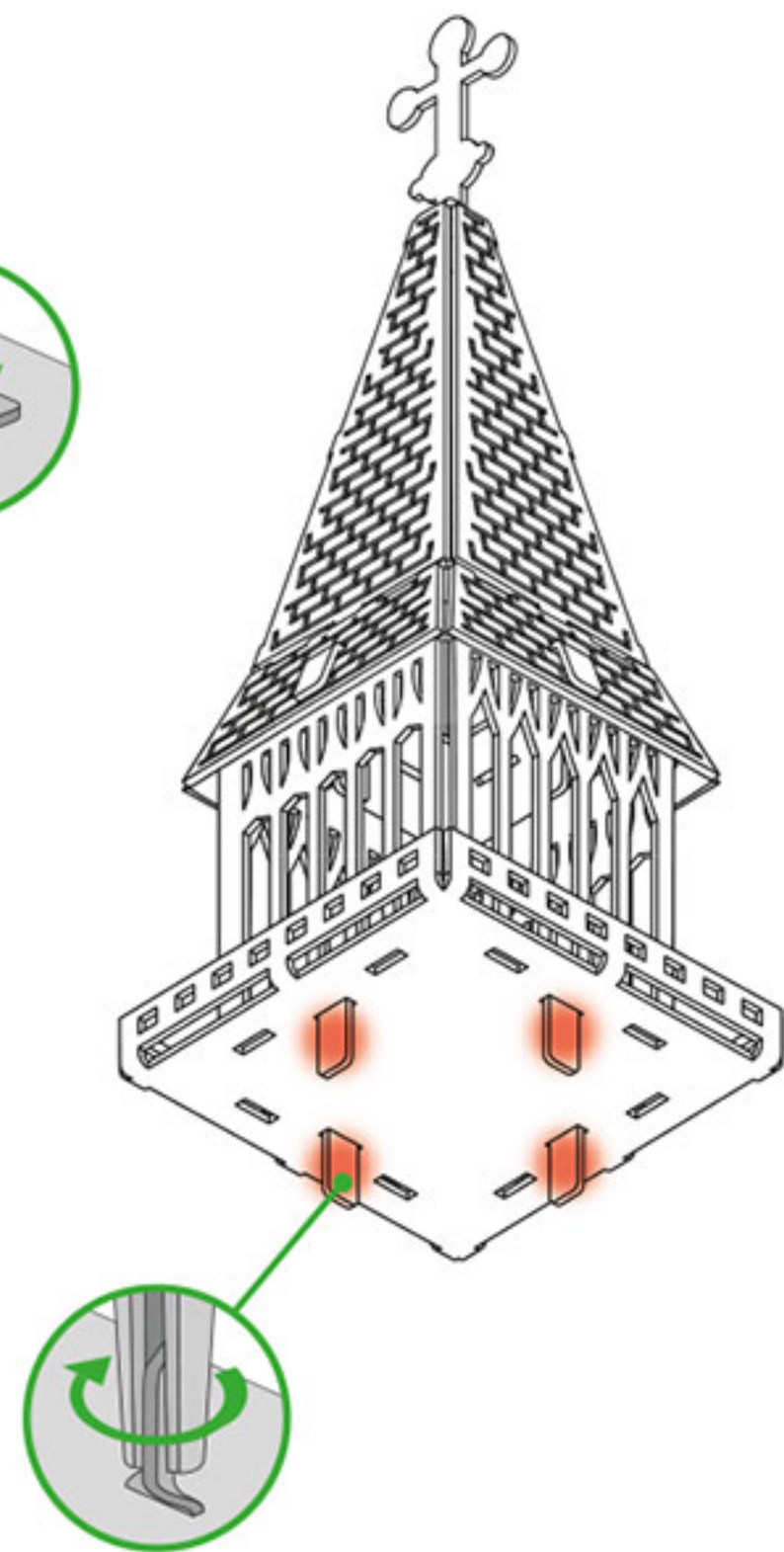

5.4

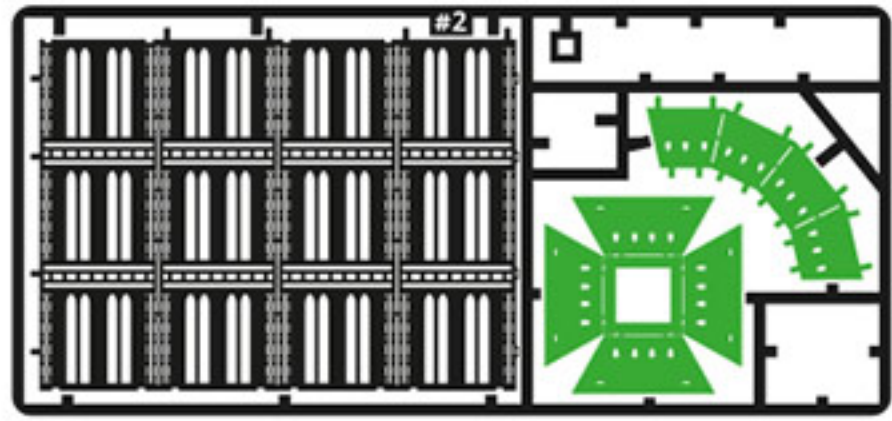

#2

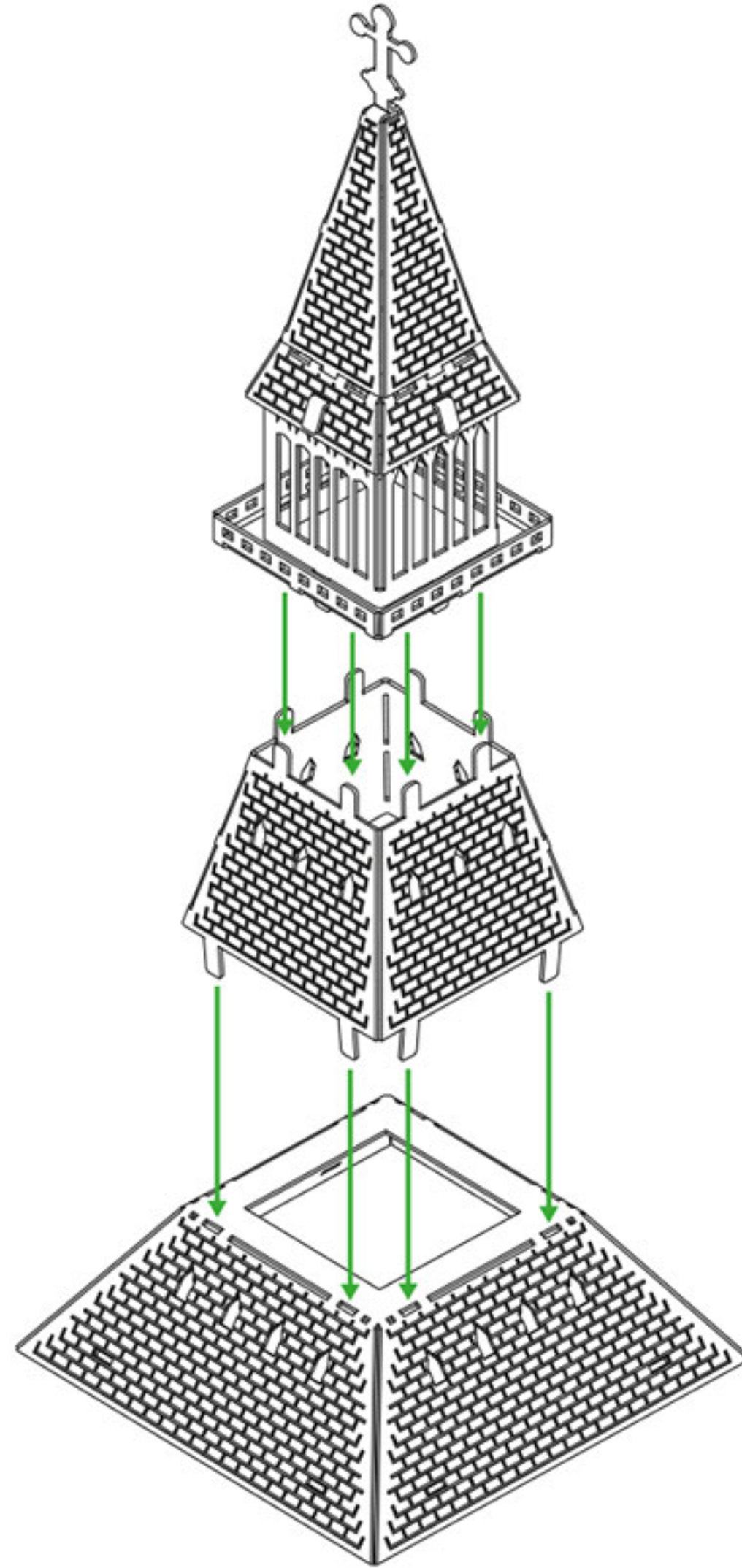
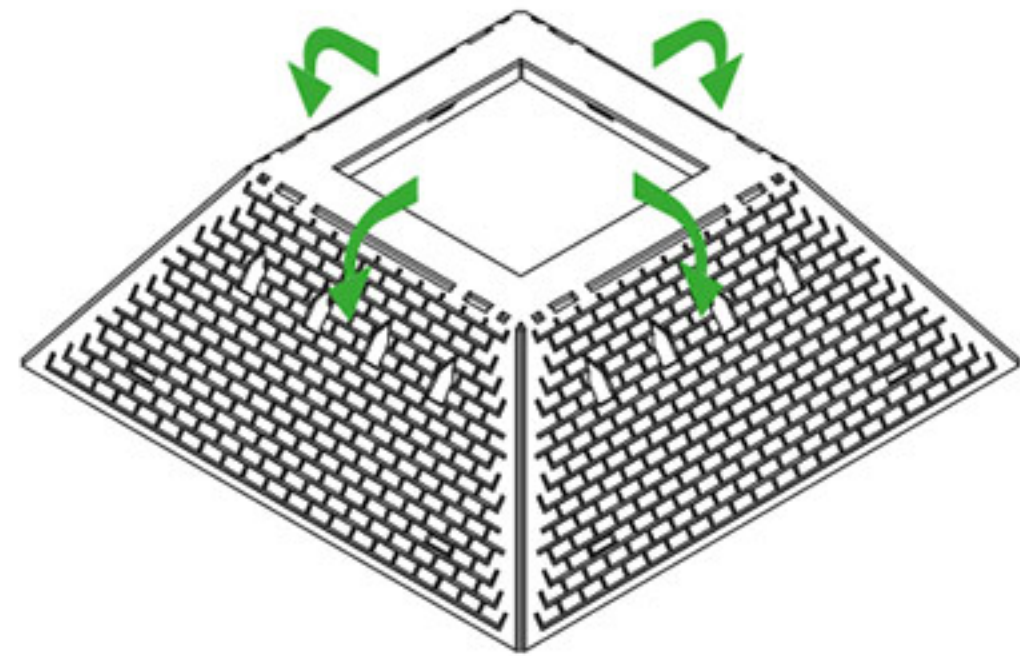
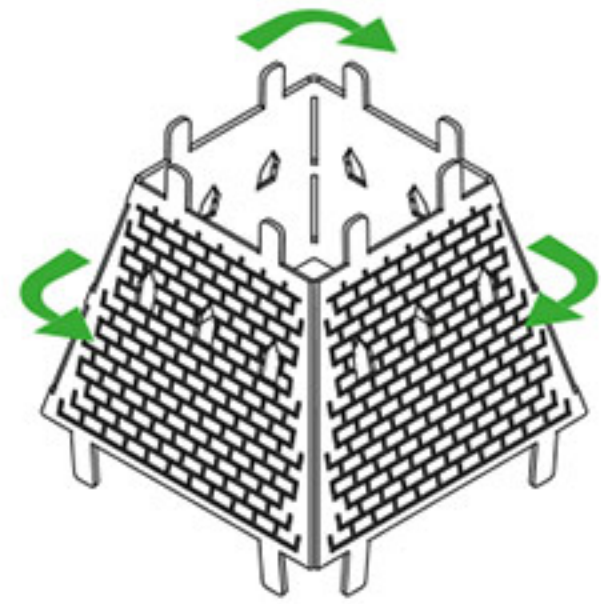

8



At this step, use this method to fix all unmarked ears

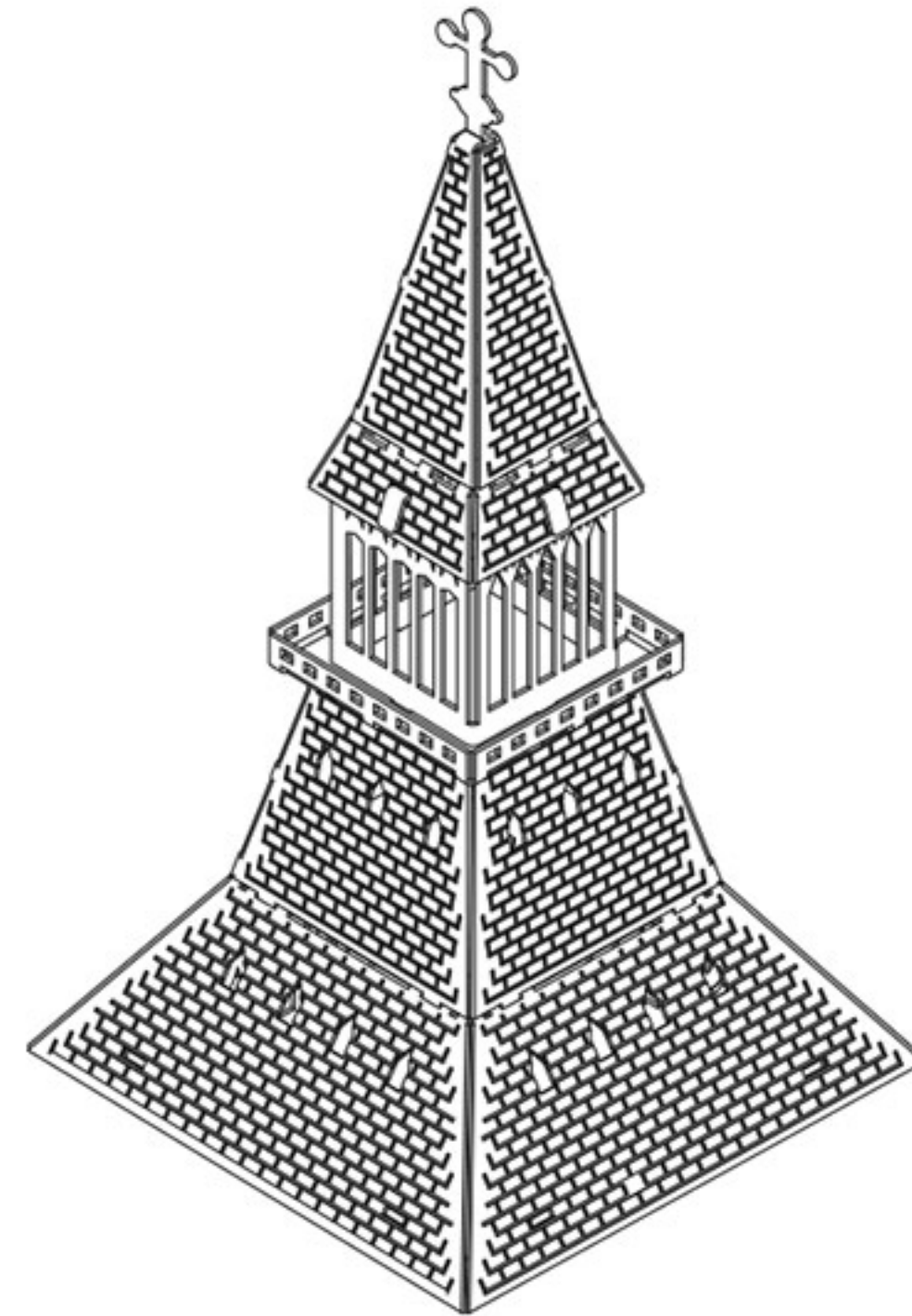

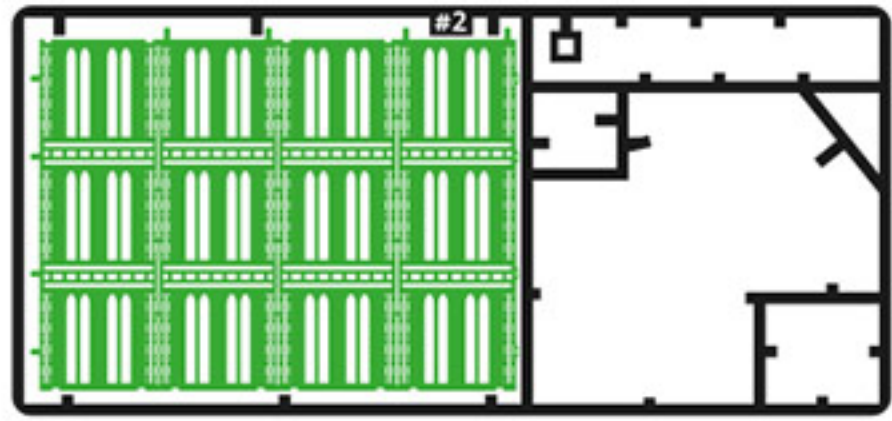

#2

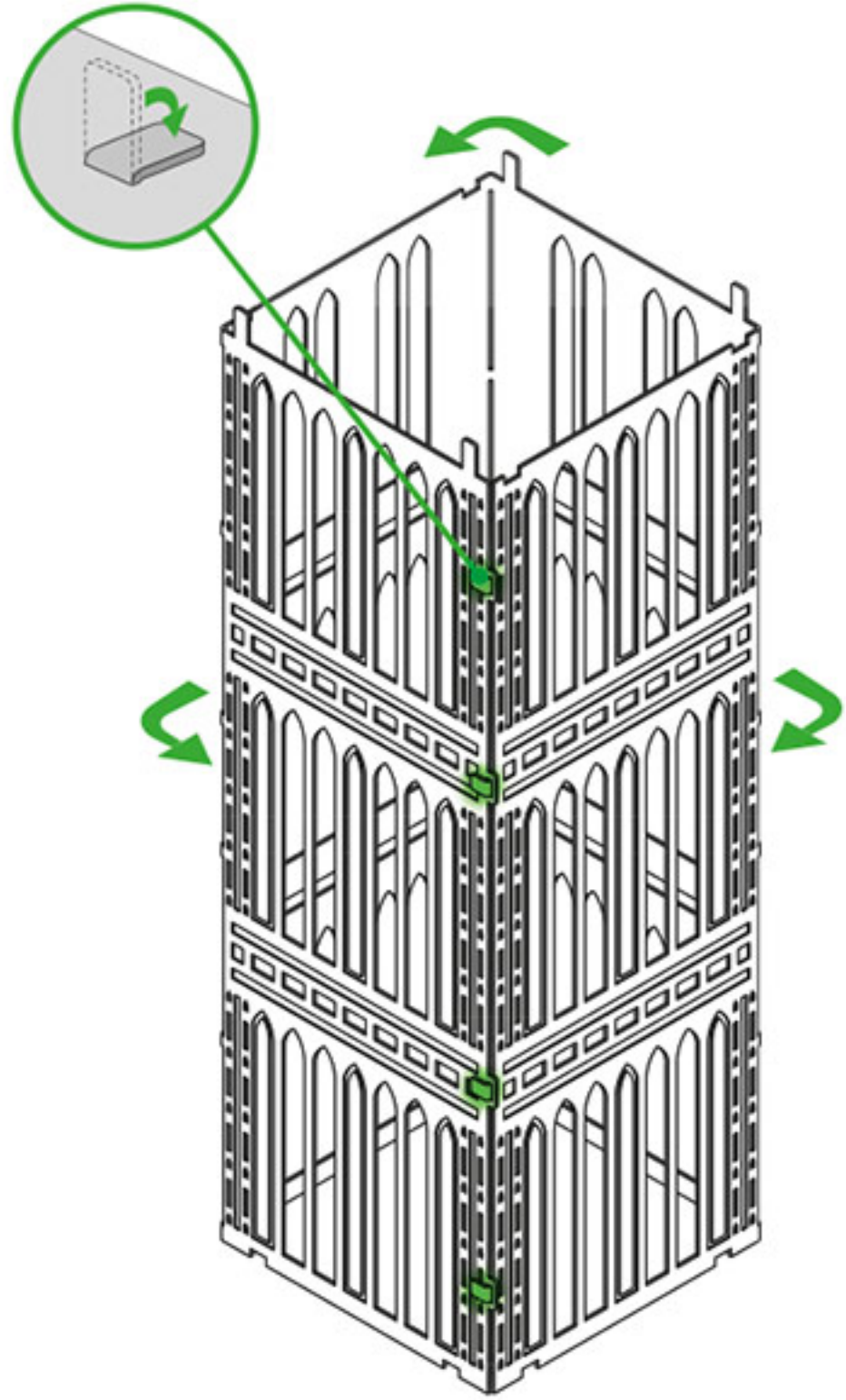

7.1

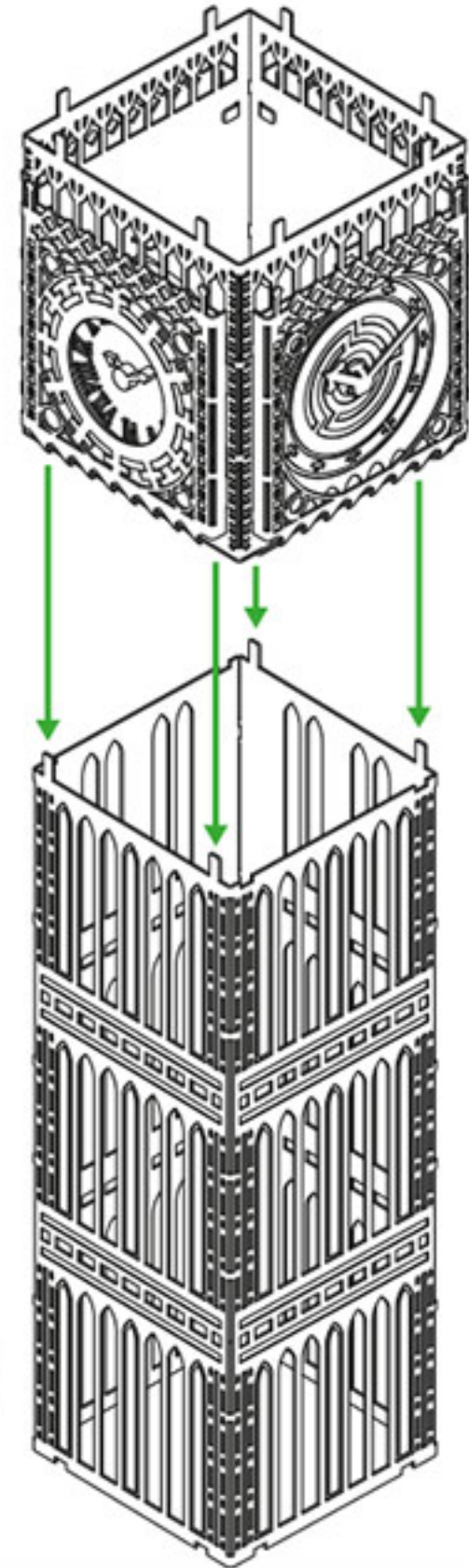

7.2

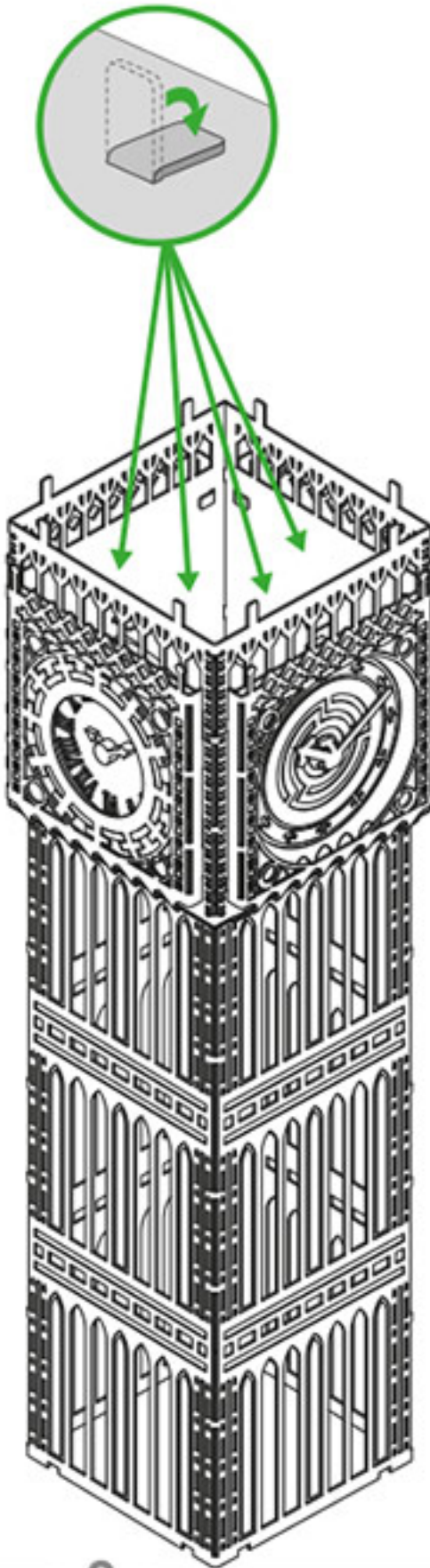

7.3

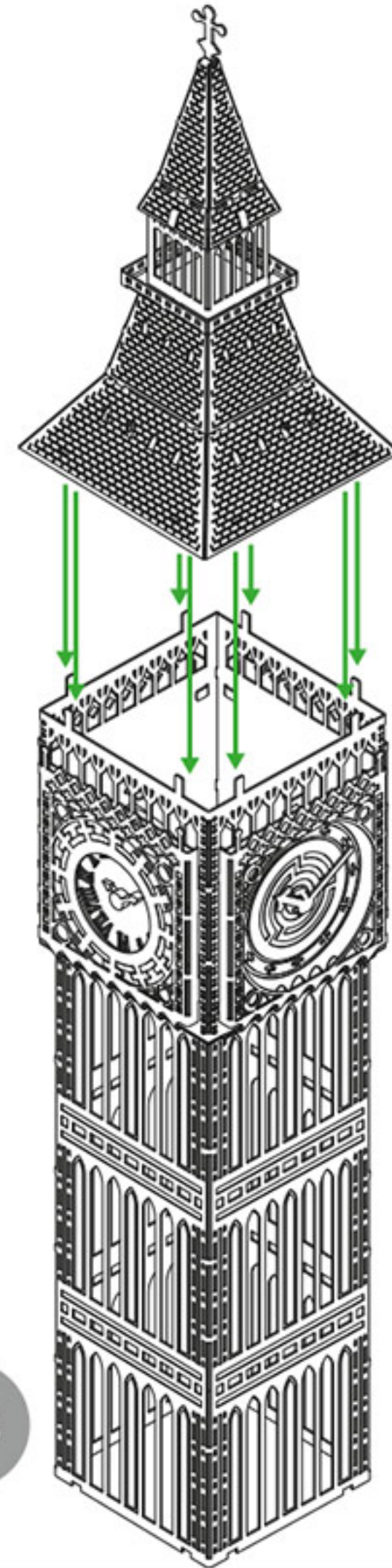

7.4

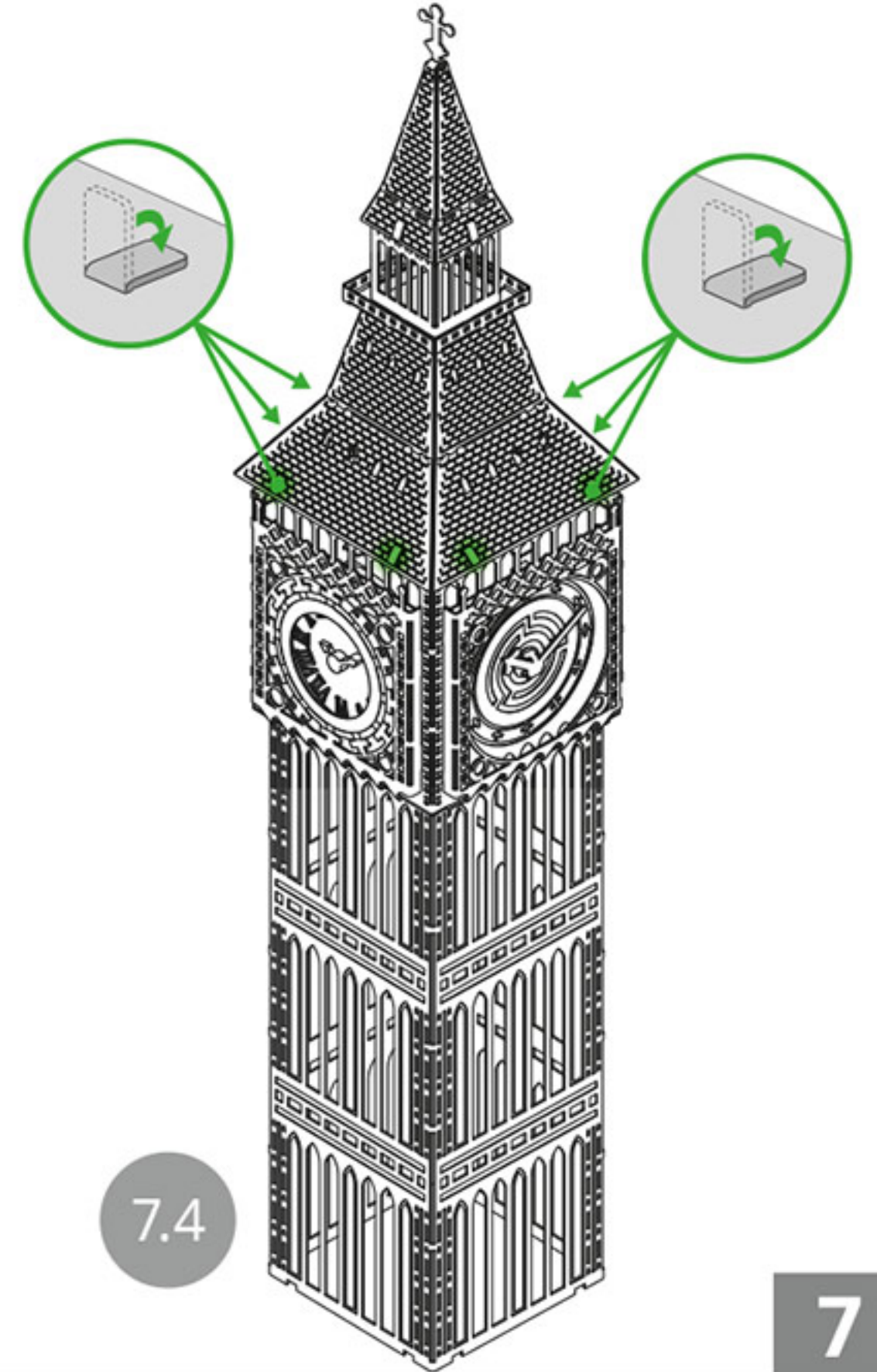

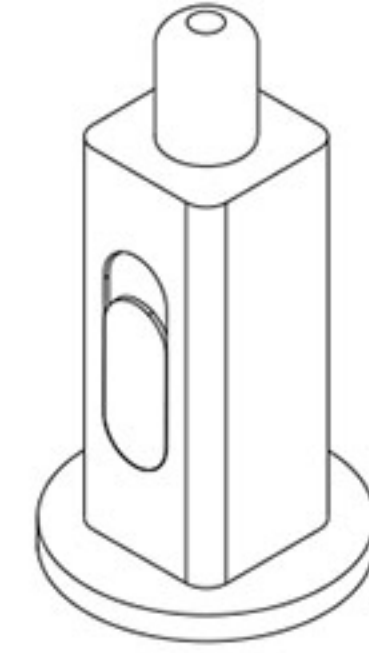
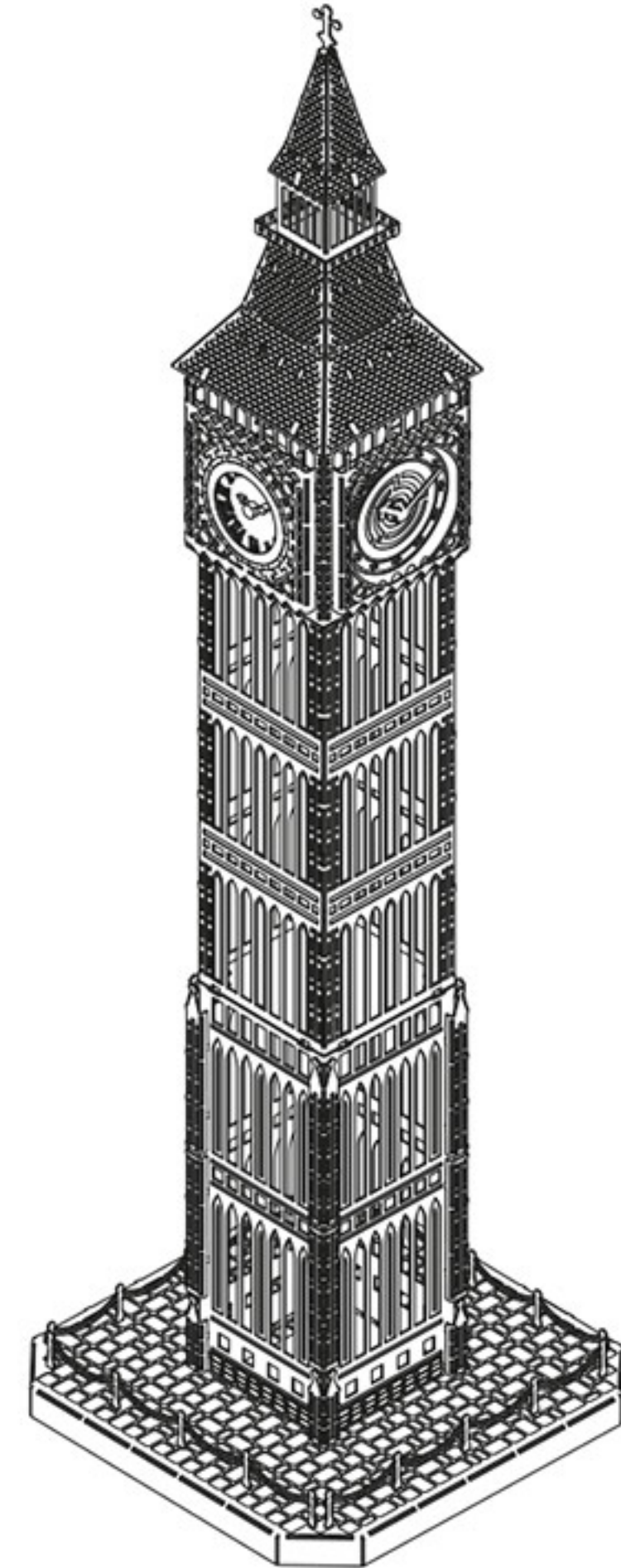
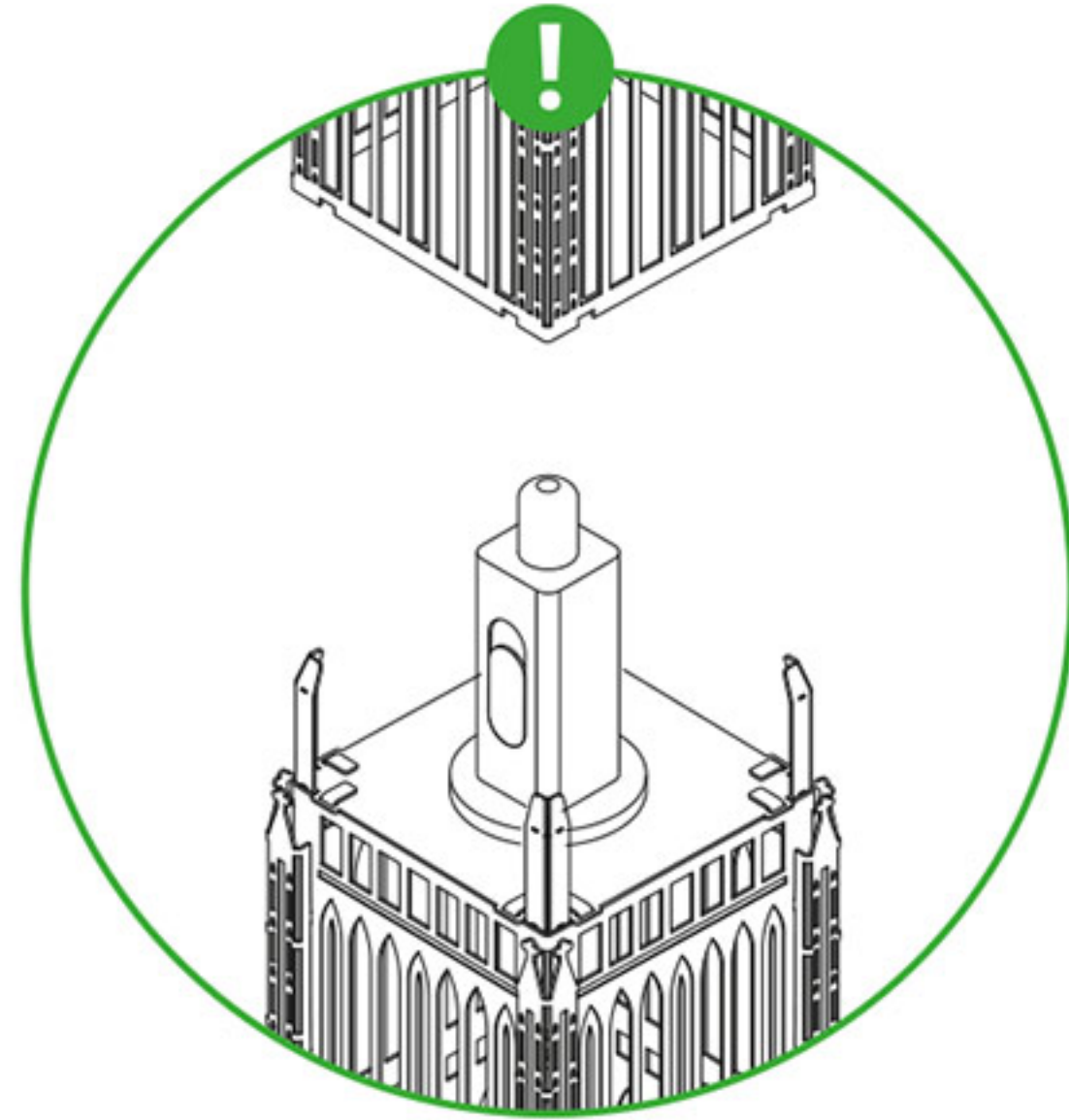
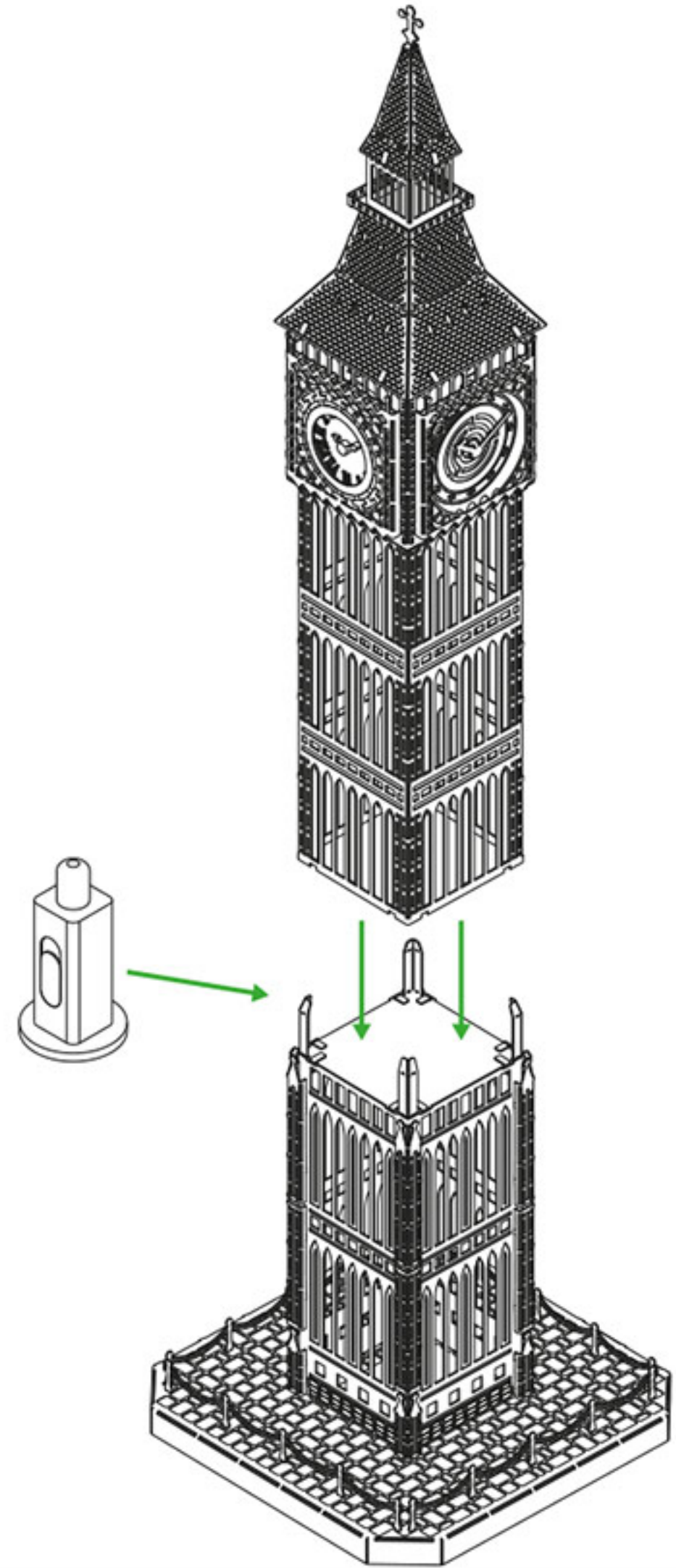

You can install the LED candle inside the tower — 20×40mm or similar (not included).

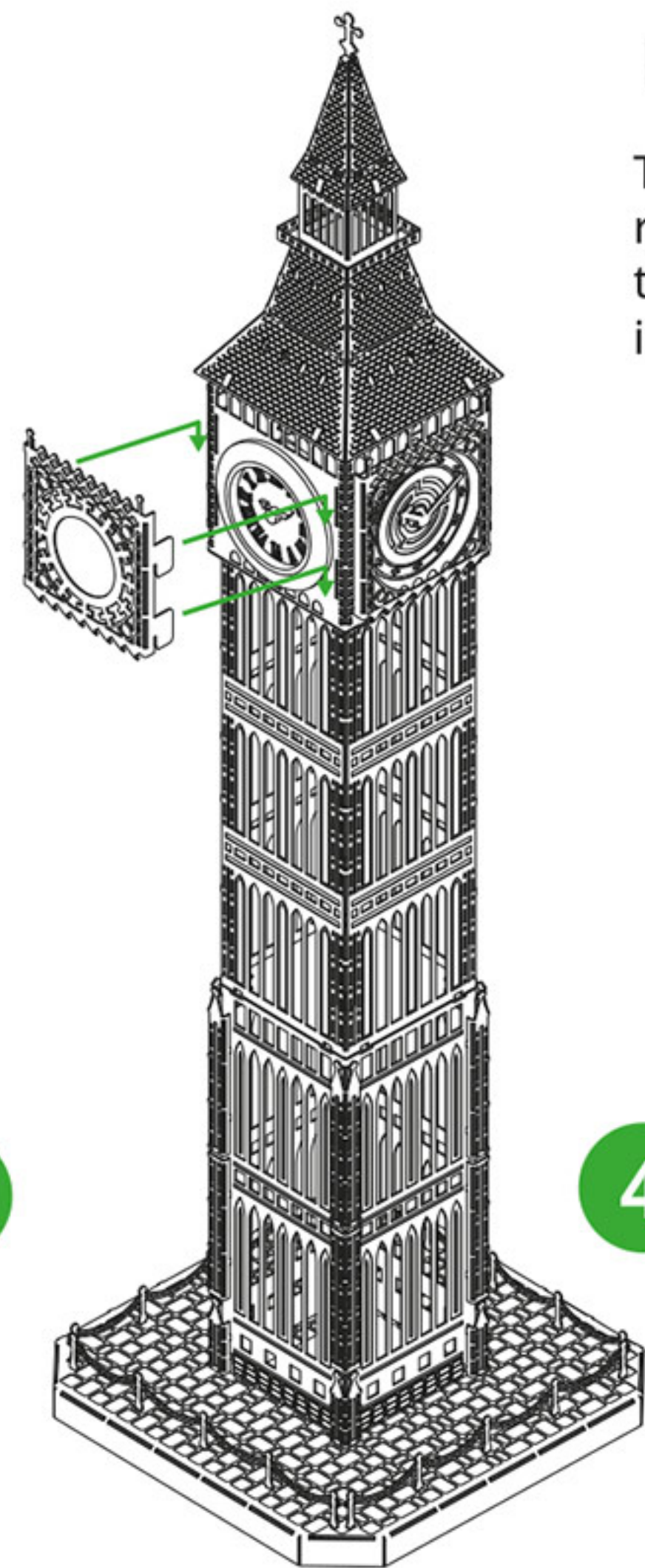
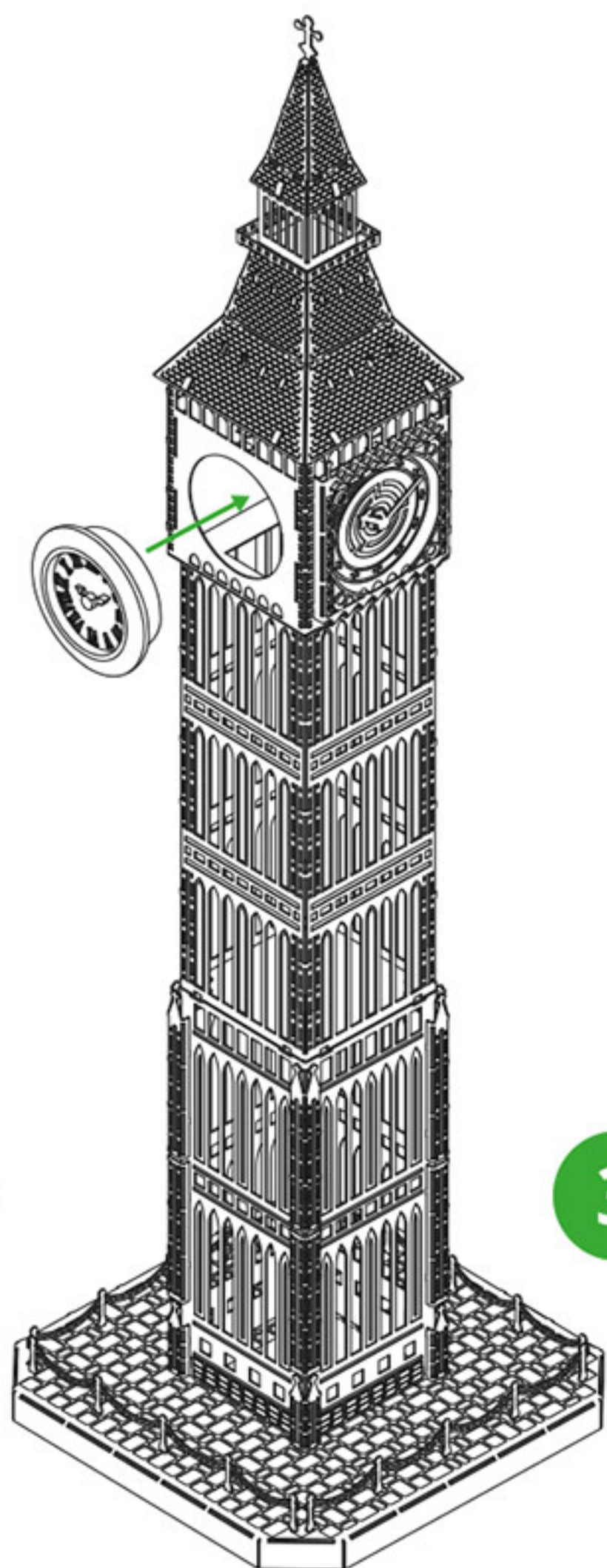
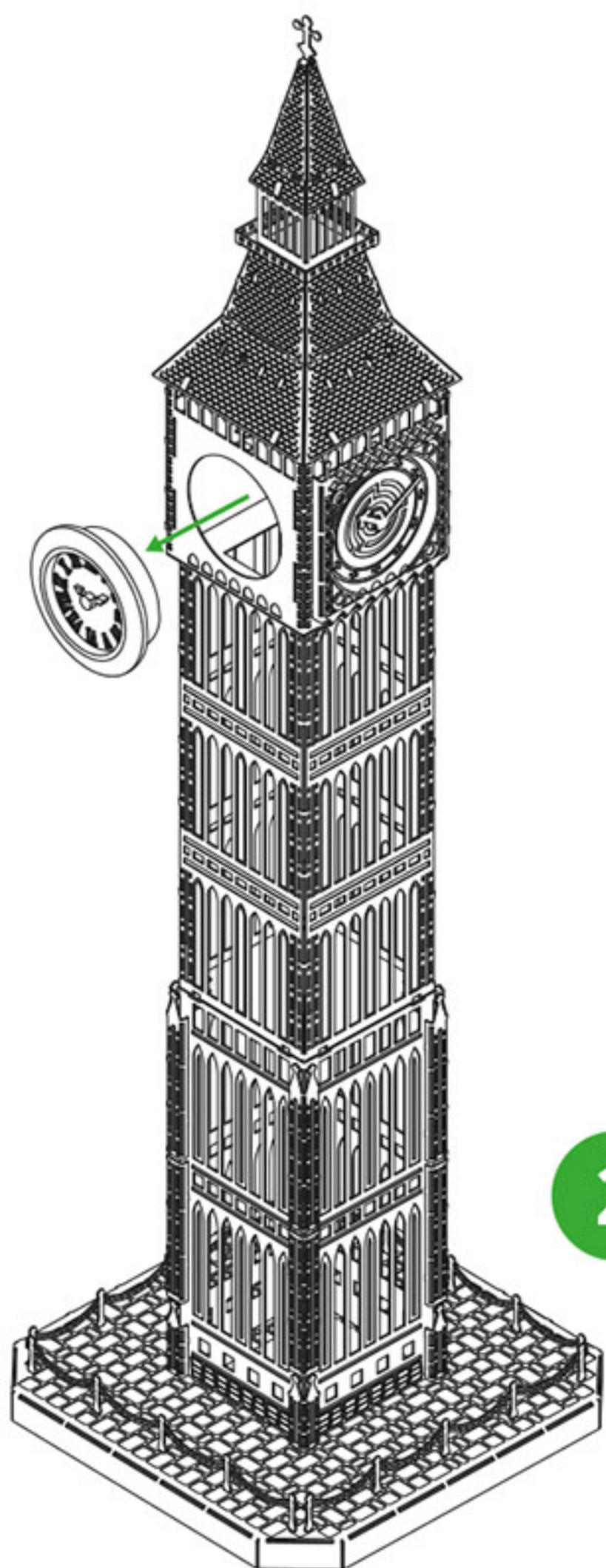
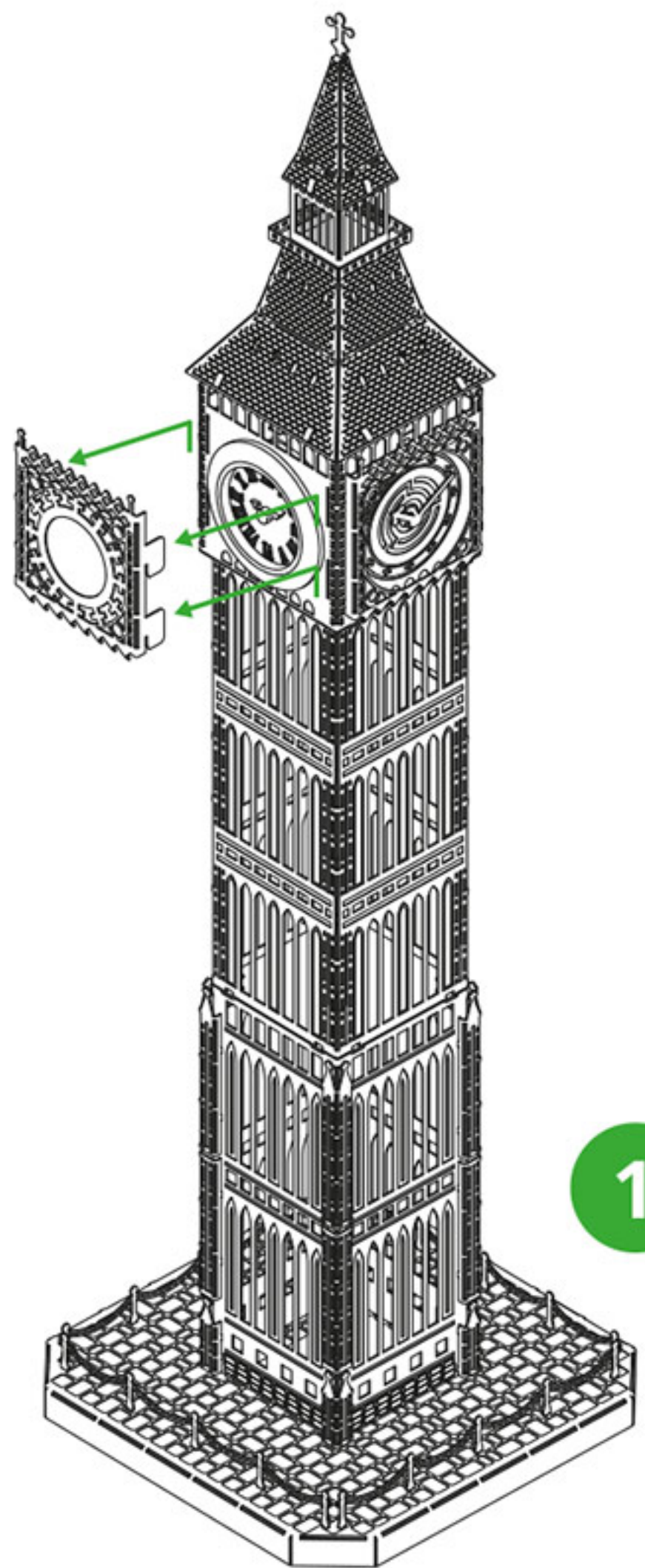

BATTERIES CHANGING

To change the battery, lift and remove the watch frame (1), take out the watch (2), replace the battery, insert the watch (3) and the frame (4)

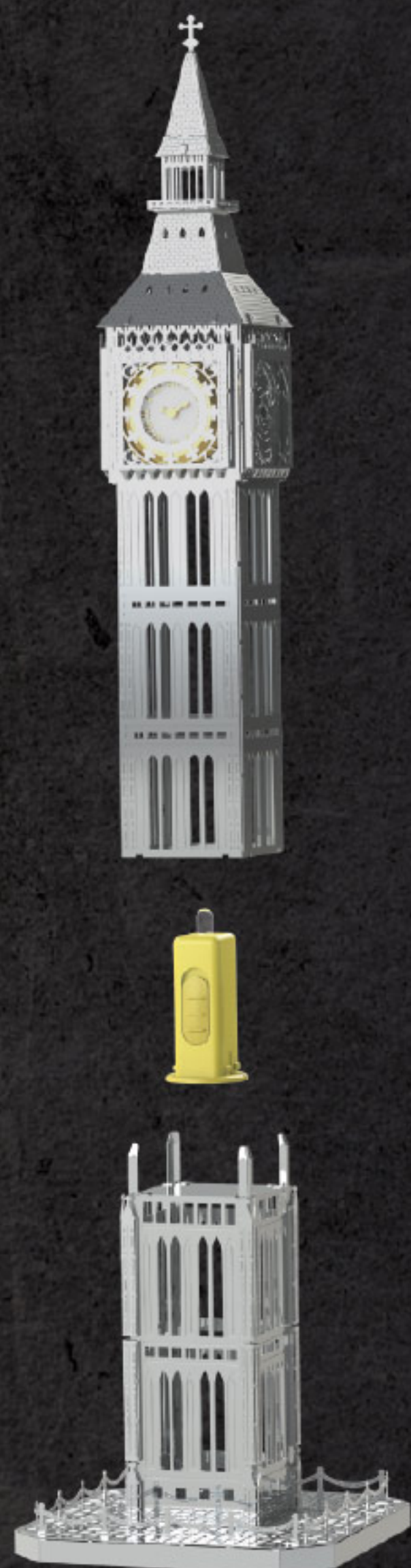
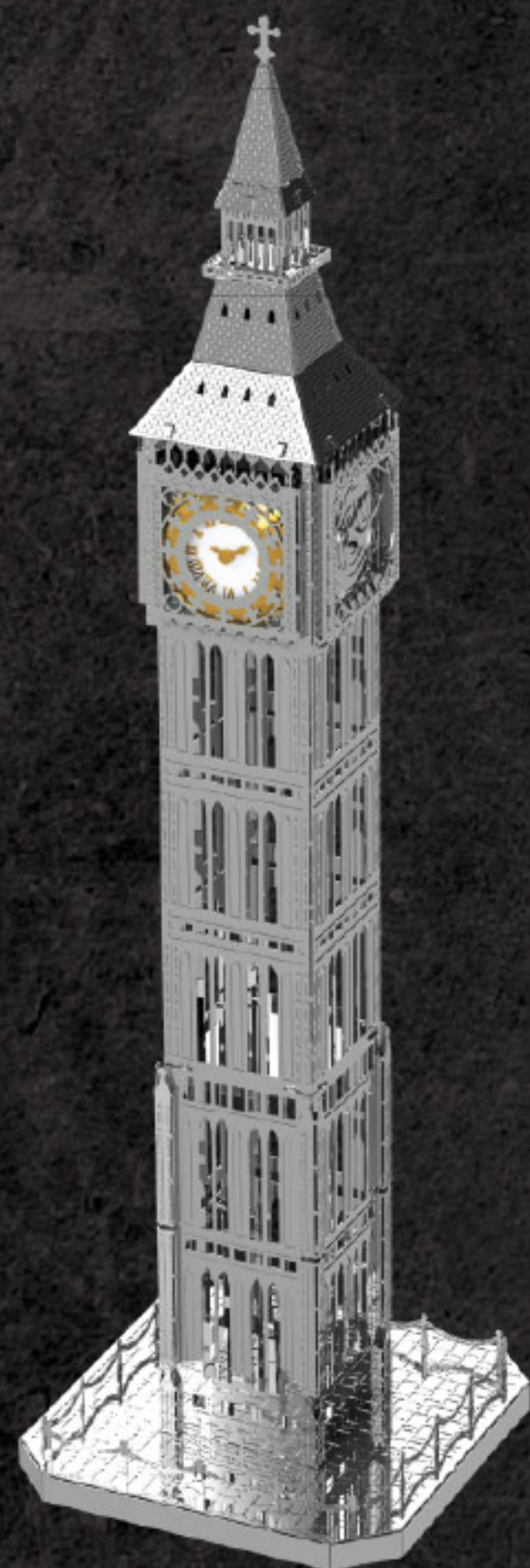

Model name:

THE GREAT BELL

Construction of the tower began on 28 September 1843. Elizabeth Tower, originally referred to as the Clock Tower, but more popularly known as Big Ben, was raised as a part of Charles Barry's design for a new Palace of Westminster, after the old palace was largely destroyed by fire on 16 October 1834. Although Barry was the chief architect of the neo-gothic palace, he turned to Augustus Pugin for the design of the Clock Tower, which resembles earlier Pugin designs, including one for Scarsbrick Hall in Lancashire.

Designed in Ukraine



Made in China

Product number: SKU073

Product material: Stainless steel

Number of metal sheets: 4 pcs

Finish product size: L11.34" x W3.19" x H3.19" (L28,8cm x W8,1cm x H8,1cm)

⚠️ WARNING!

The product contains small and/or sharp parts. Not suitable for children under 3 years of age. Cut/remove the band that keeps the spring in place ONLY WITHIN the spring chamber/container. DO NOT cut the restraining band outside the assembled spring chamber, as the spring will unwind with force.

In order to avoid possible injury from sharp edges, please carefully discard the metal sheet after parts have been removed. This product is not a toy. Keep out of reach of children.

Conforms to CPSIA and CE standards. The product complies with the requirements of EN 71-1,2,3; ASTM F963, REACH, AS/NZS 8124, GB 6675



Difficulty level

No expiration date

MODEL
BUILDING
KIT
@hobbadd.cn

霍布德



Collect the Best

Includes: steel sheets, clock mechanism, pliers, file, gloves, polishing cloth, user's guide. LR626×1pc battery and LED candle are not included.

ALL RIGHTS RESERVED
© Metal-Time Inc., USA

www.metal-time.com
info@metal-time.com