



METAL[®]
TIME



REMARKABLE DOUGLAS

3D Metal Mechanical
Model Building Kit

Assembly instructions

Collect the Best

146 PIECES

8 hours

Windup mechanism
Metal craft / Desk stand

AGES
14+

STANDARD FIXING OF FASTENERS AND SYMBOLS

When assembling the model, don't rush, avoid pointing details at yours or anyone else's face. If one of the parts has a sharp edge, please file it down. Use pliers and additional tools to assemble the model. Each kit contains a cloth for wiping and polishing the model once it's assembled.

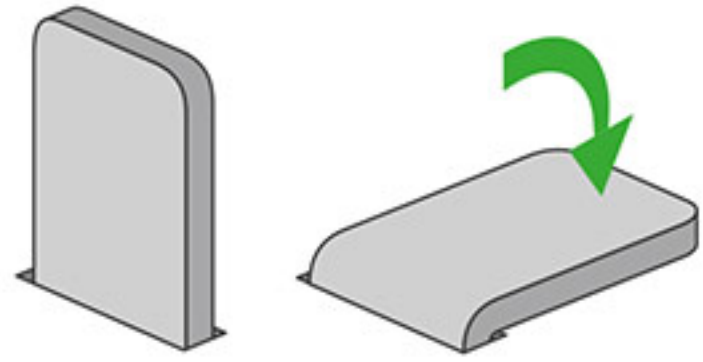

If there are no additional designations, use the standard fixing method



Twist the eyelet 45°

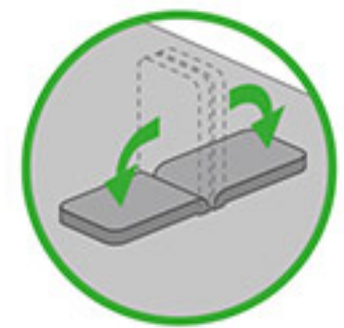

Bend the ears 90°

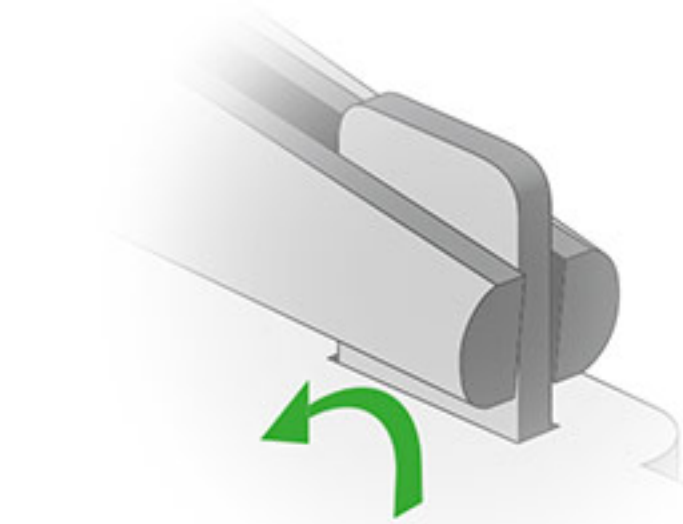

Use pliers to bend the fasteners



Assemble/bend parts symmetrically



The parts of the mechanism should rotate (move) easily

MODEL PARTS AND ASSEMBLY TOOLS



#1

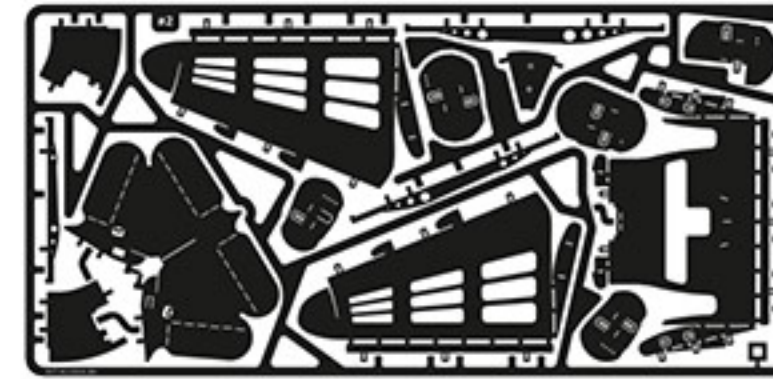

#2



#3

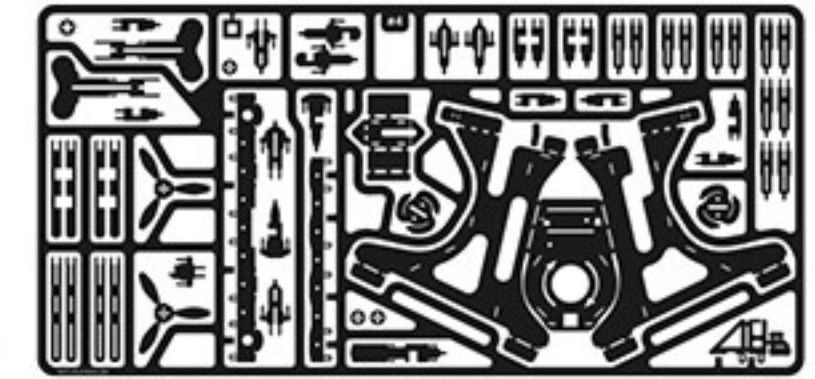

#4

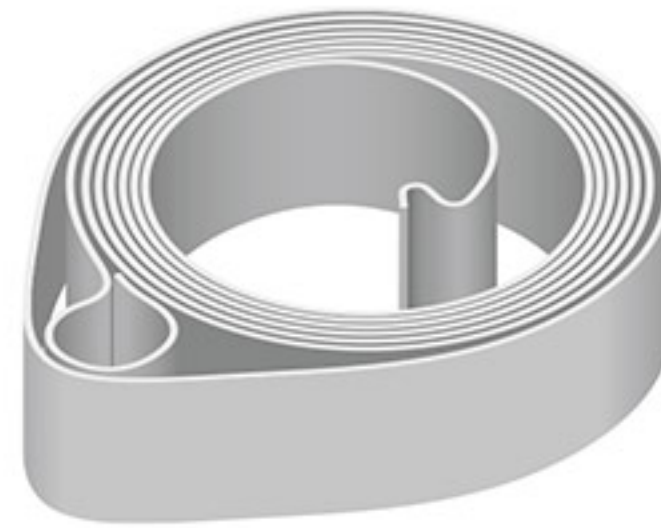

Spring



Bearing



G1



G2 x3



G3 x3



G4 x10



D1 x6



D2



D3



D4 x2



D5

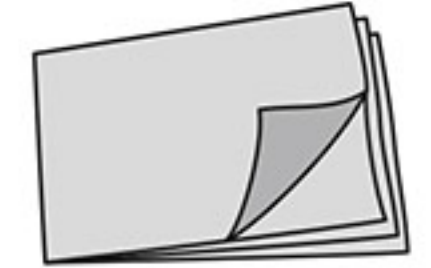
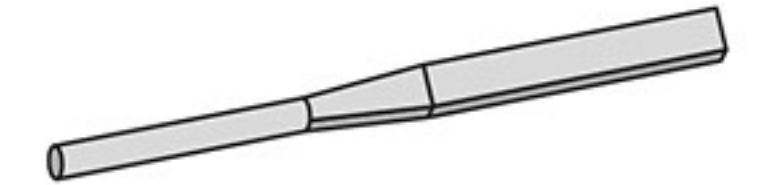
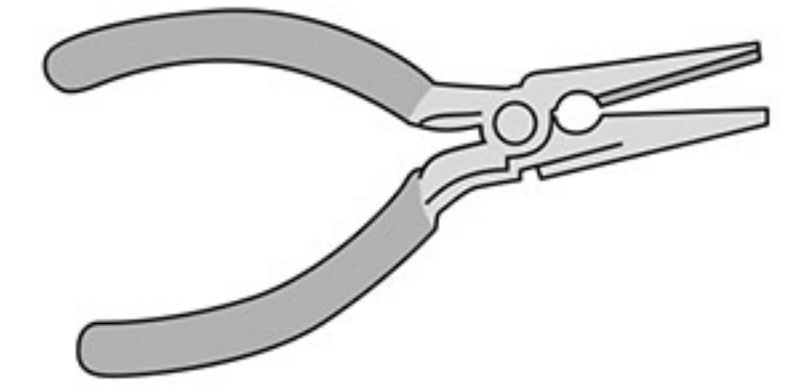

Tools

WARNING! Product contains small parts and sharp parts. Not suitable for children under 3 years of age. Please read these instructions carefully before assembly and use.

WARNING! Cut/remove the band that keeps the spring in place ONLY WITHIN the spring chamber/container. DO NOT cut the restraining band outside the assembled spring chamber, as the spring will unwind with force



#1



#3

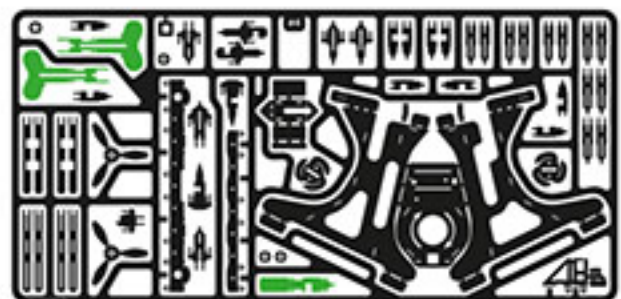

#4



D5

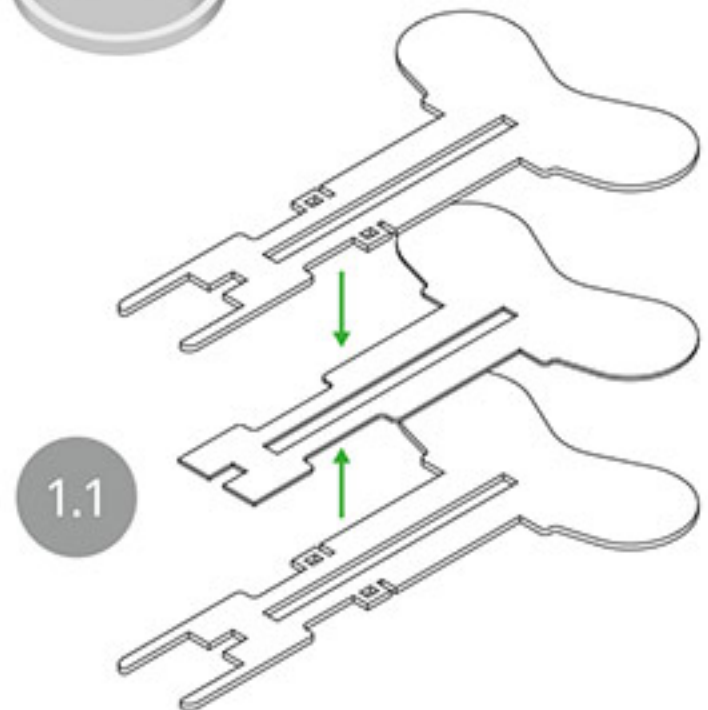

1.1

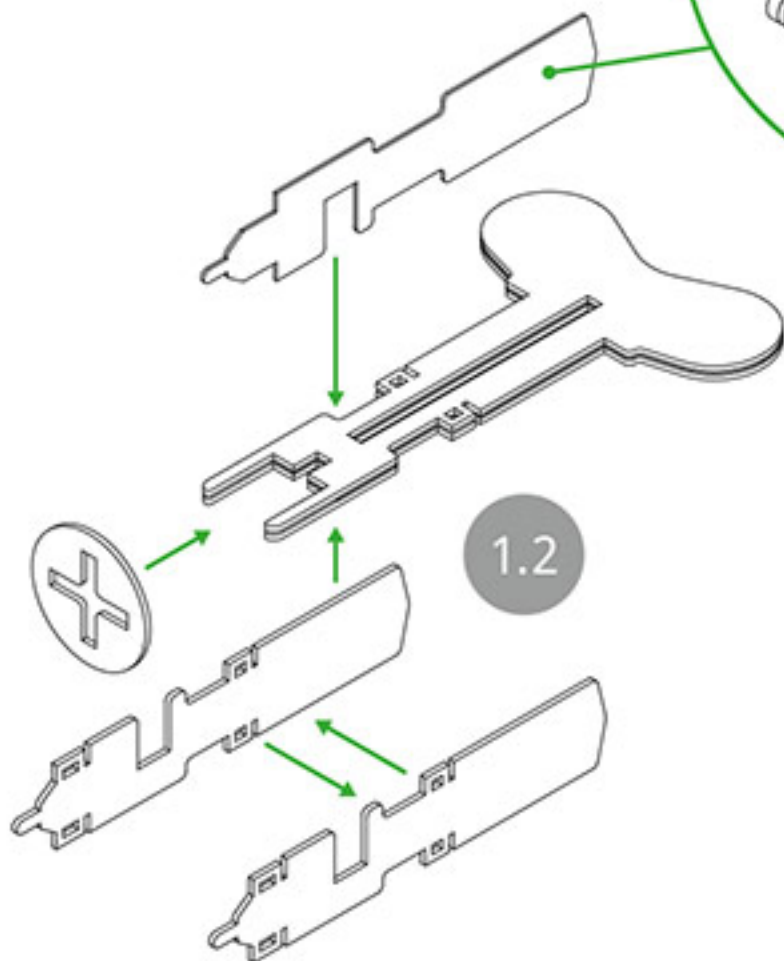

1.2

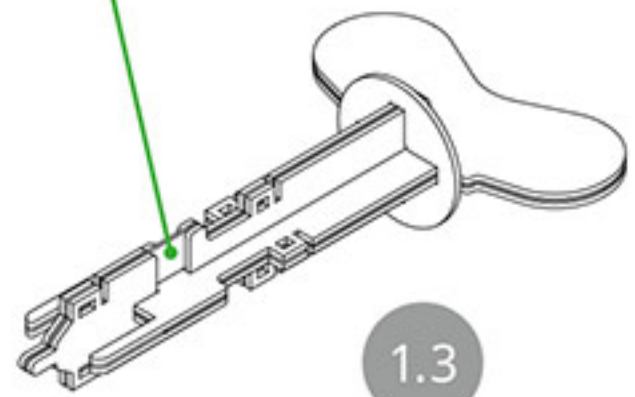

1.3

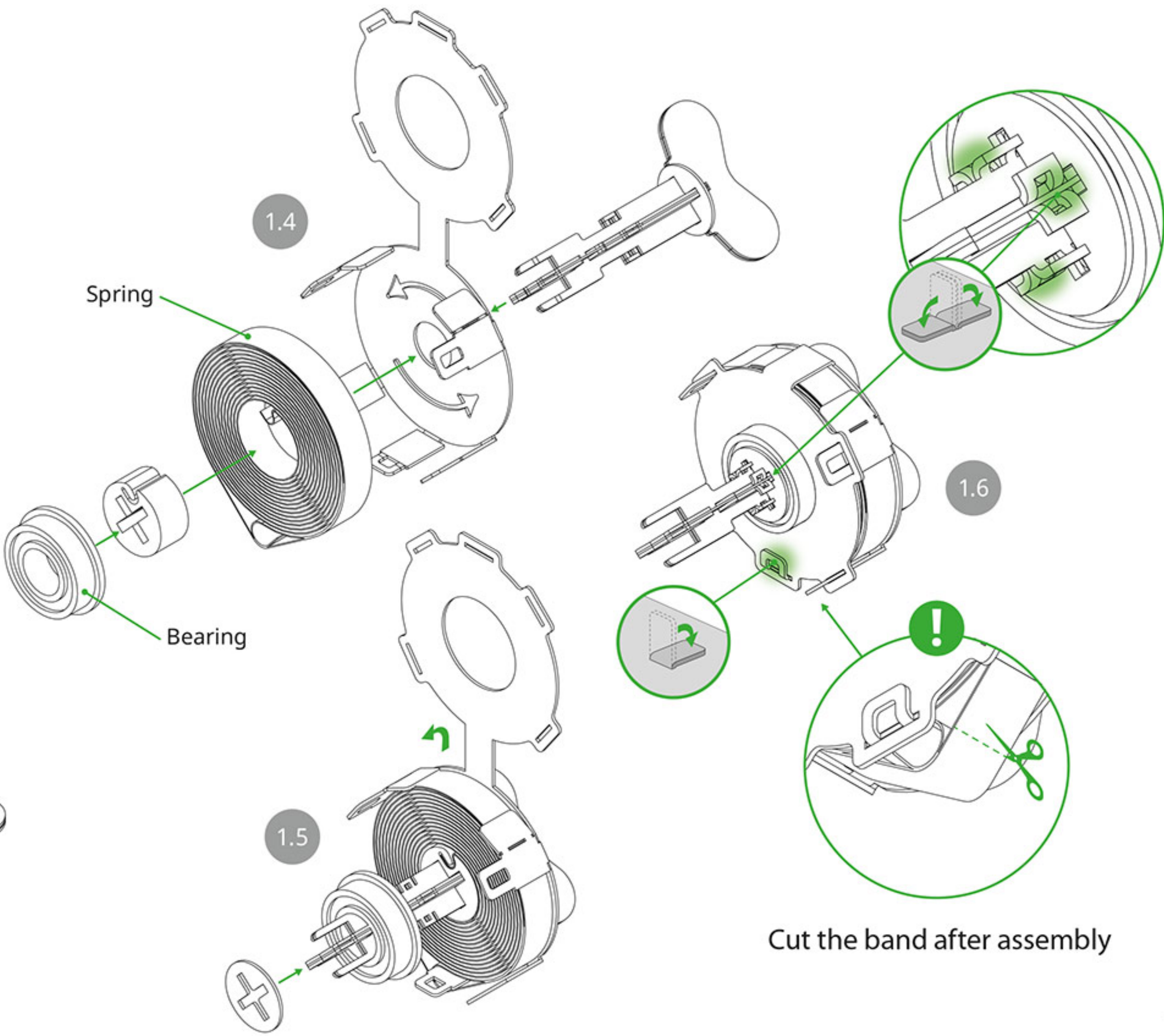
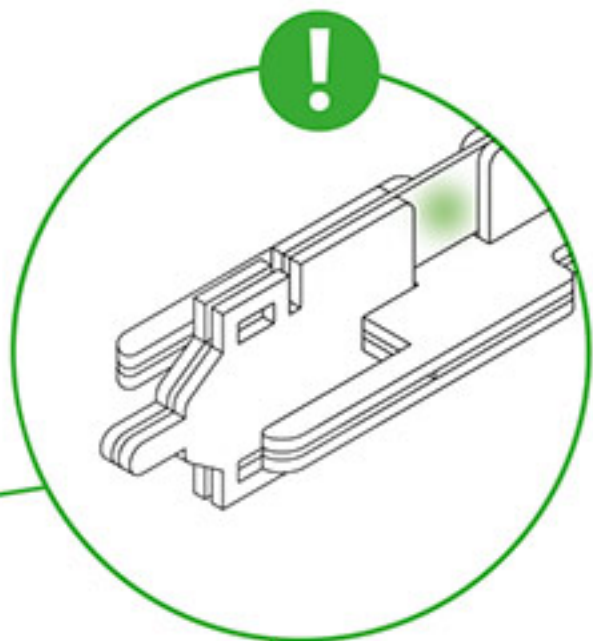
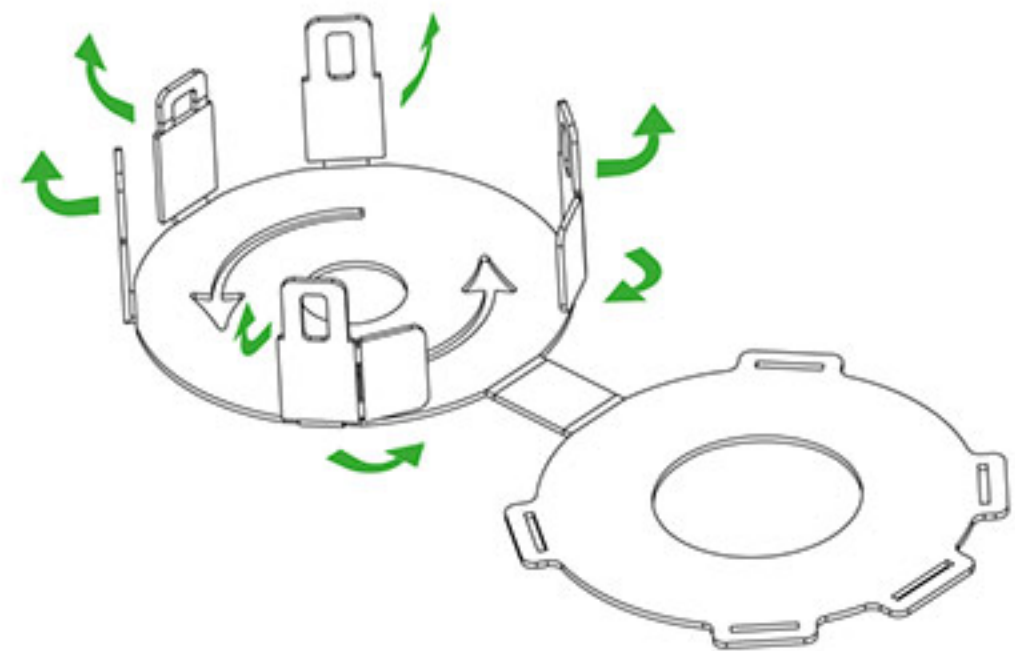

Spring

Bearing

1.4

1.5

1.6

Cut the band after assembly

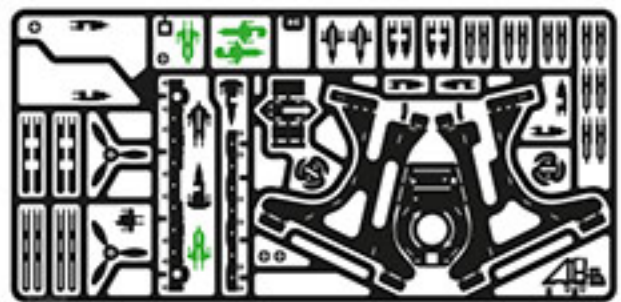

#4

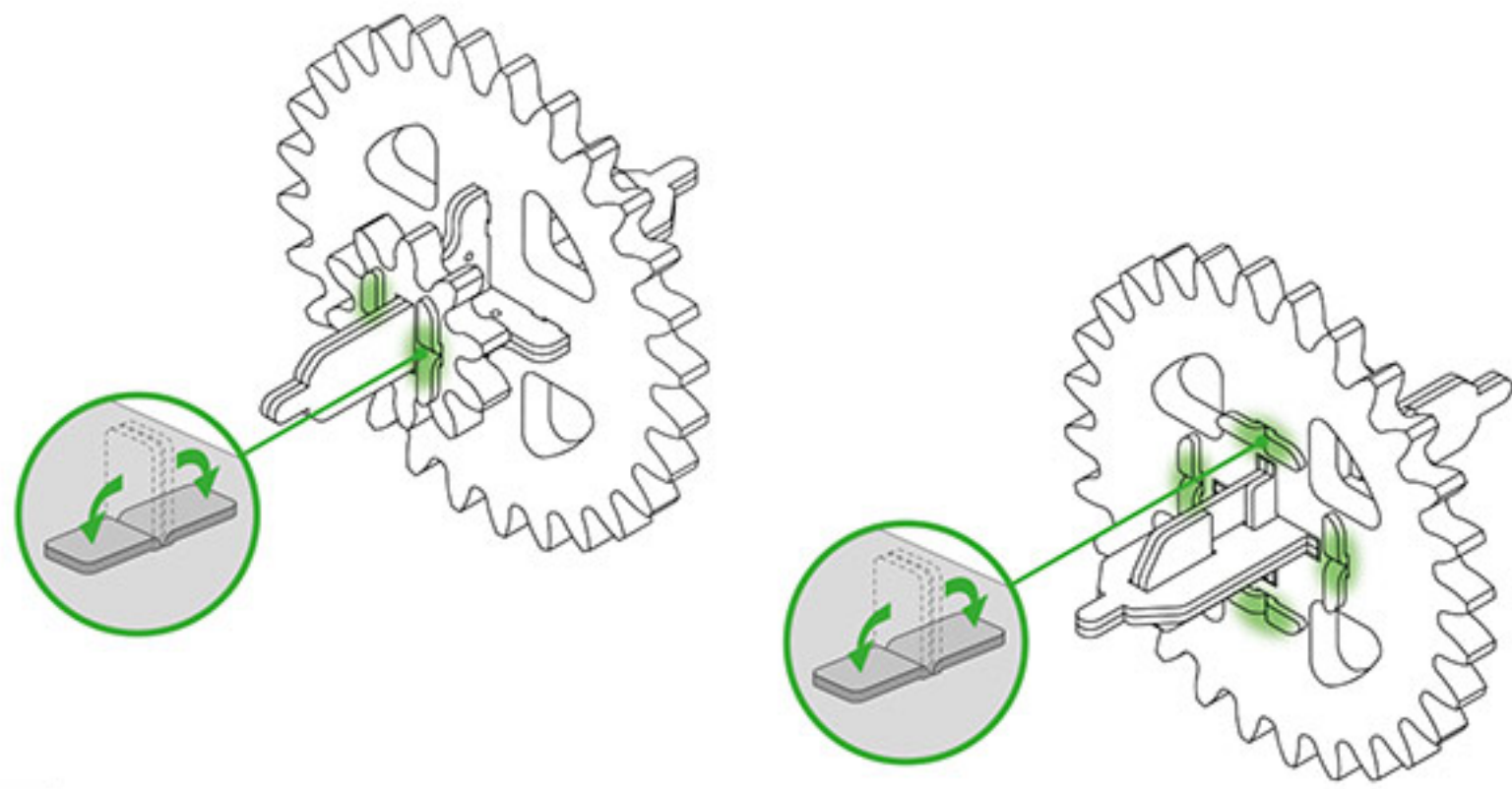
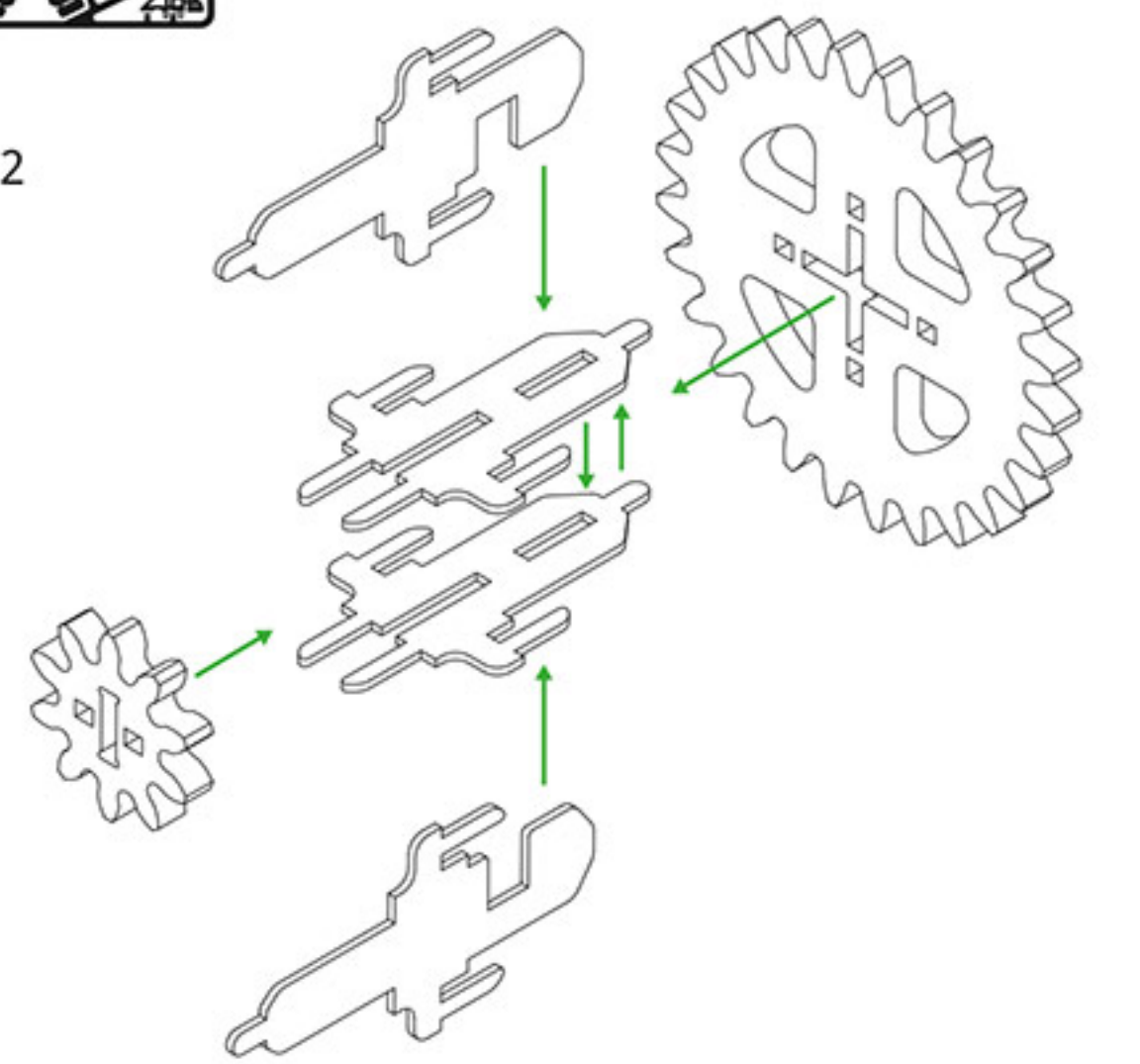
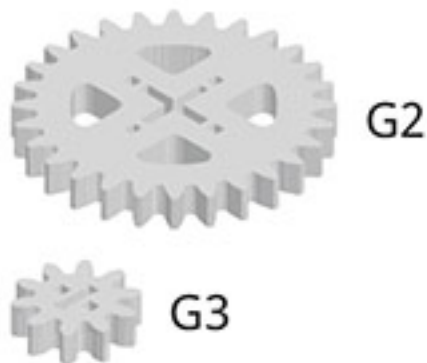

2



#3

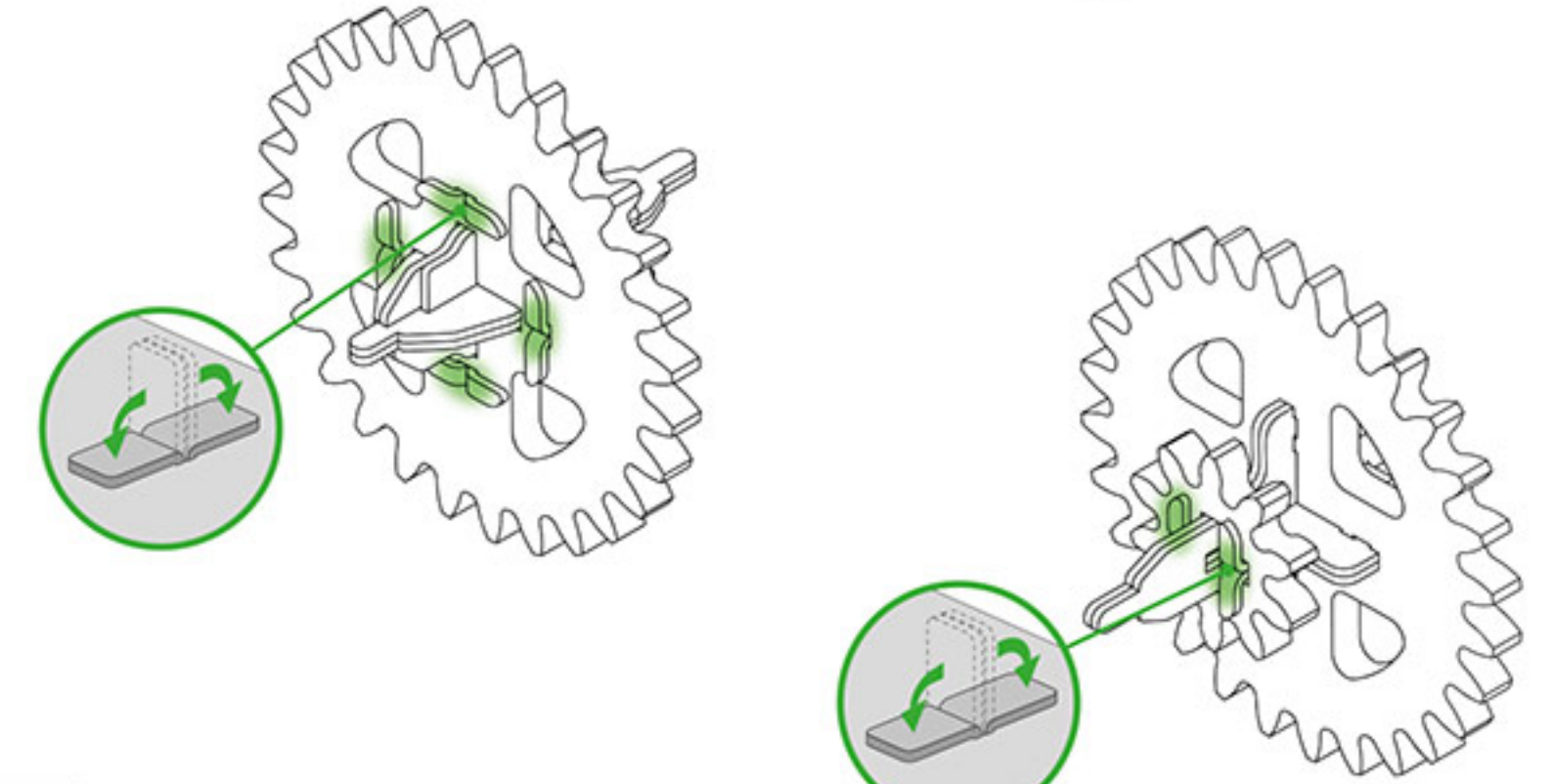
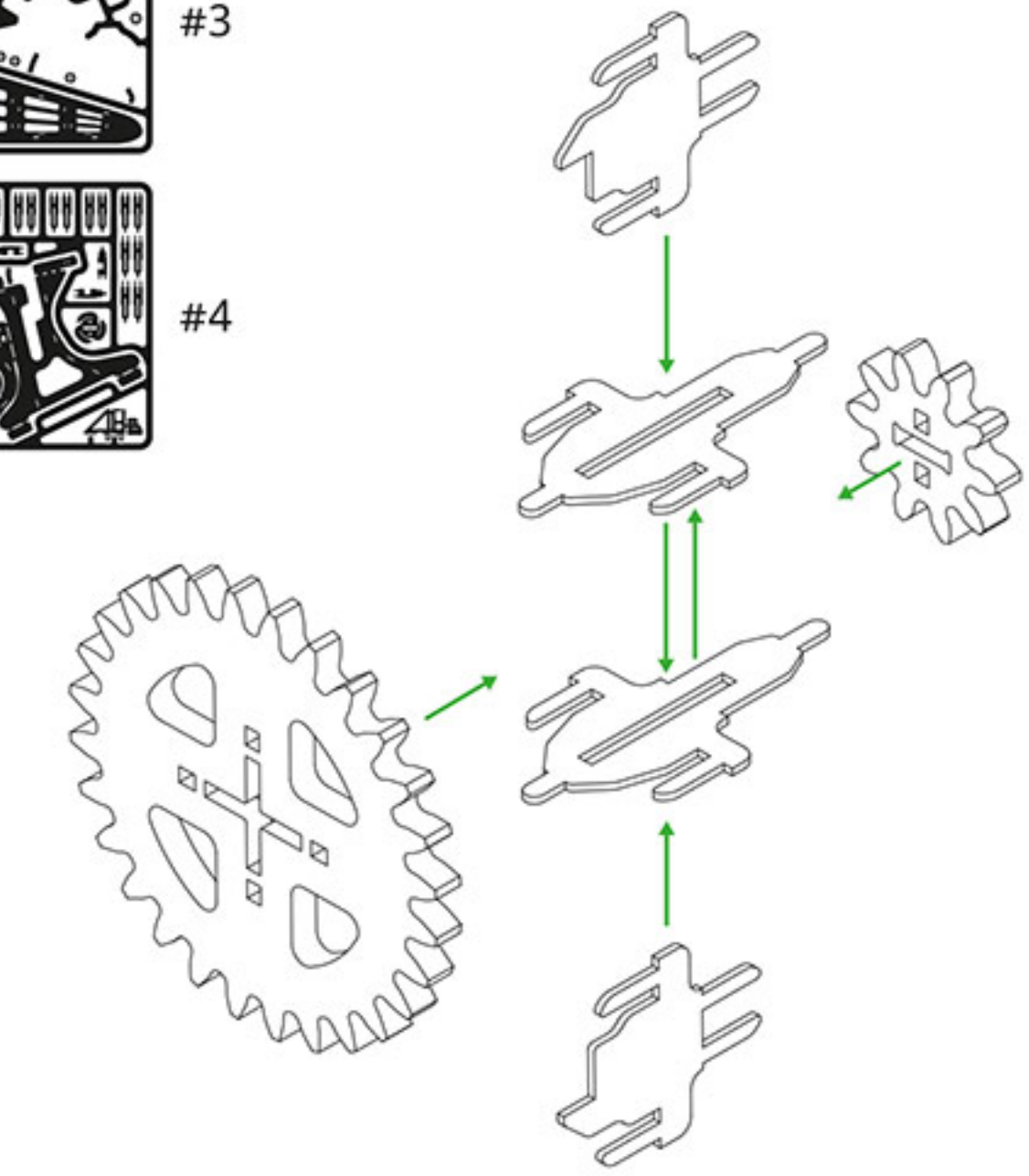
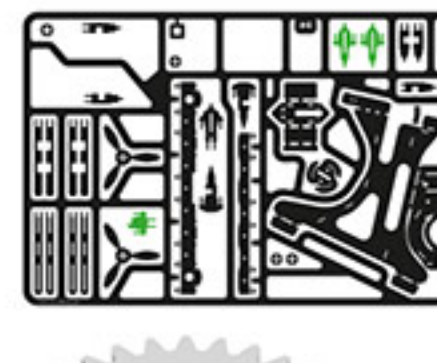

3



#3

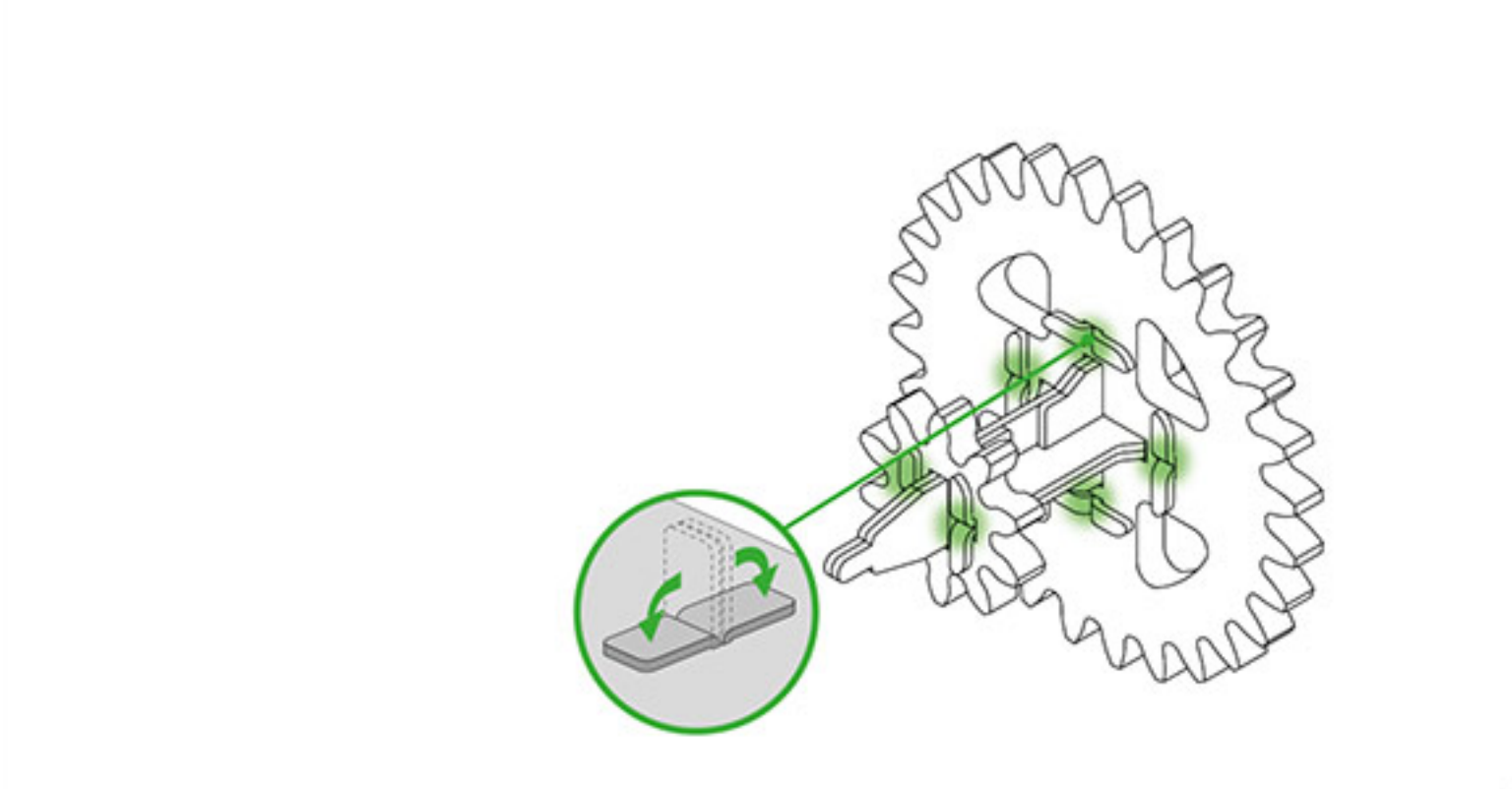
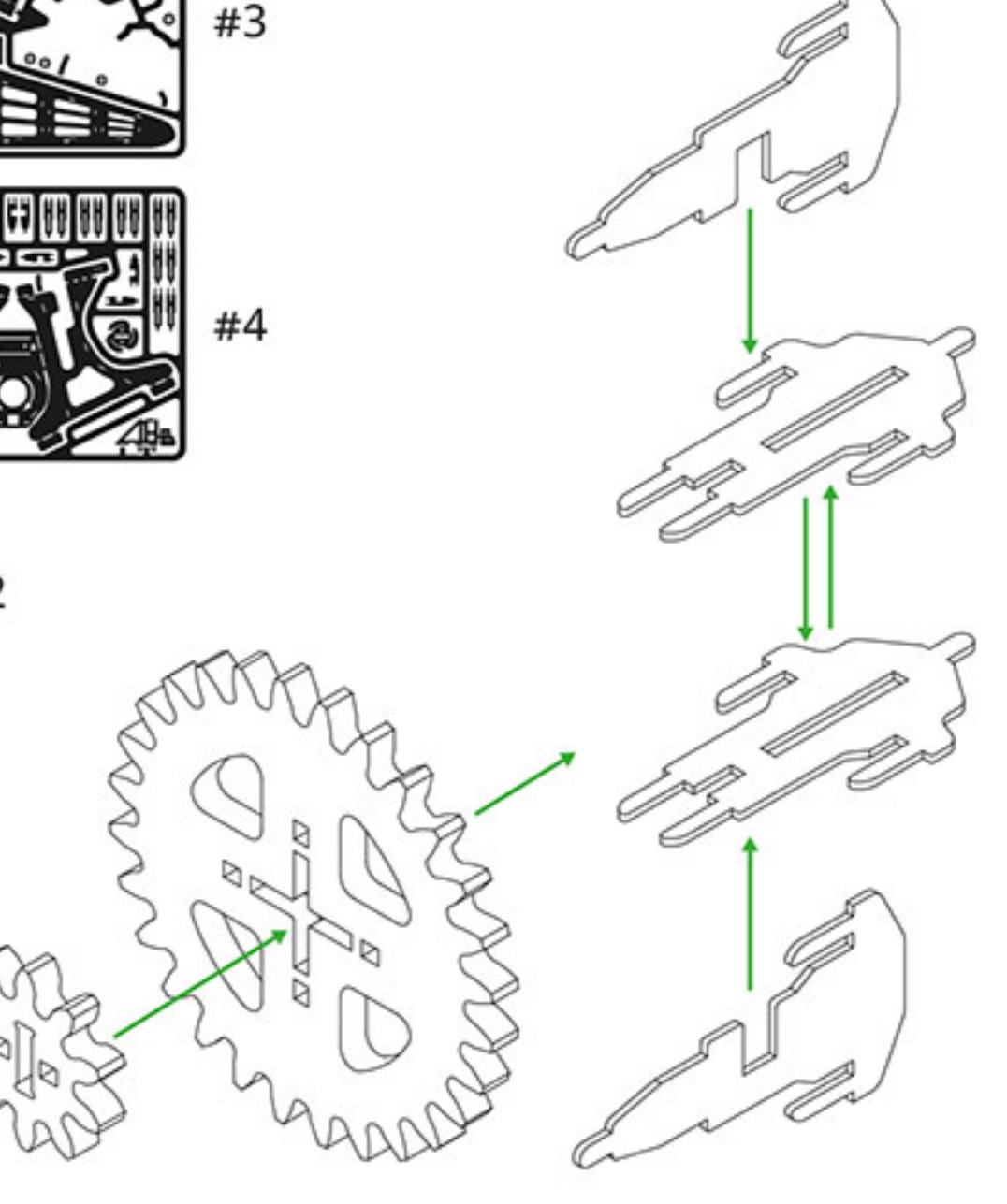
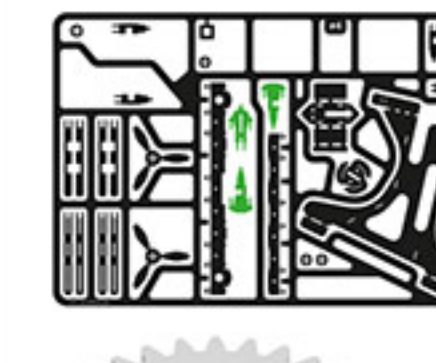

4



#3

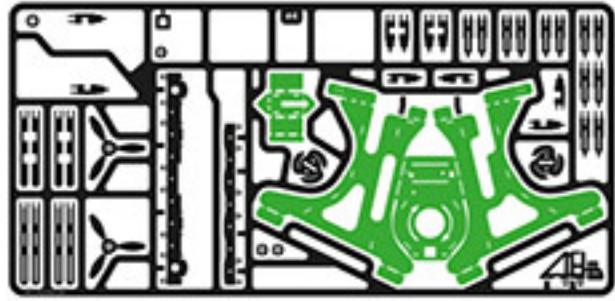

#4

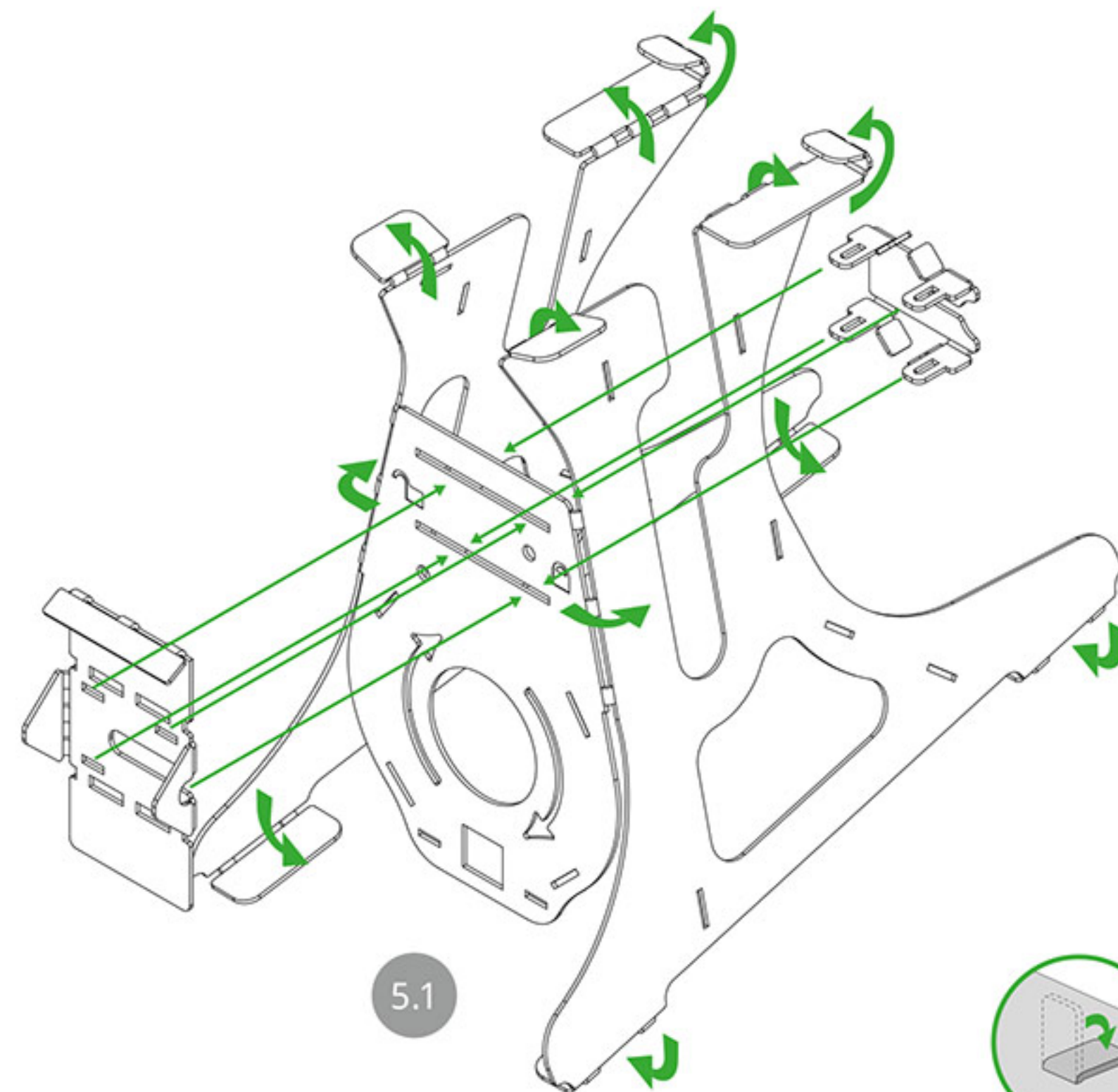
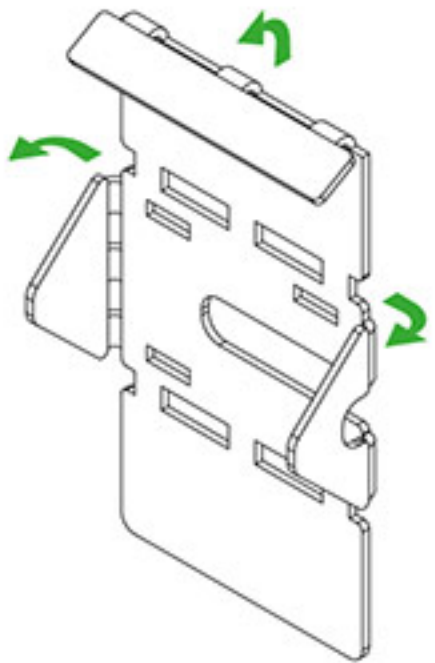
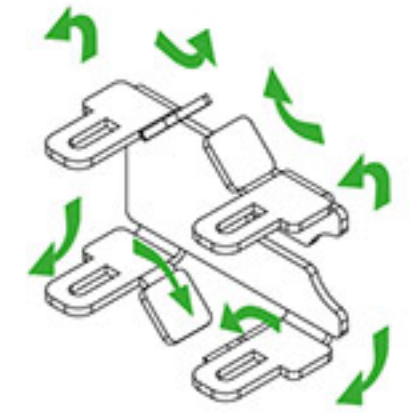

5.1

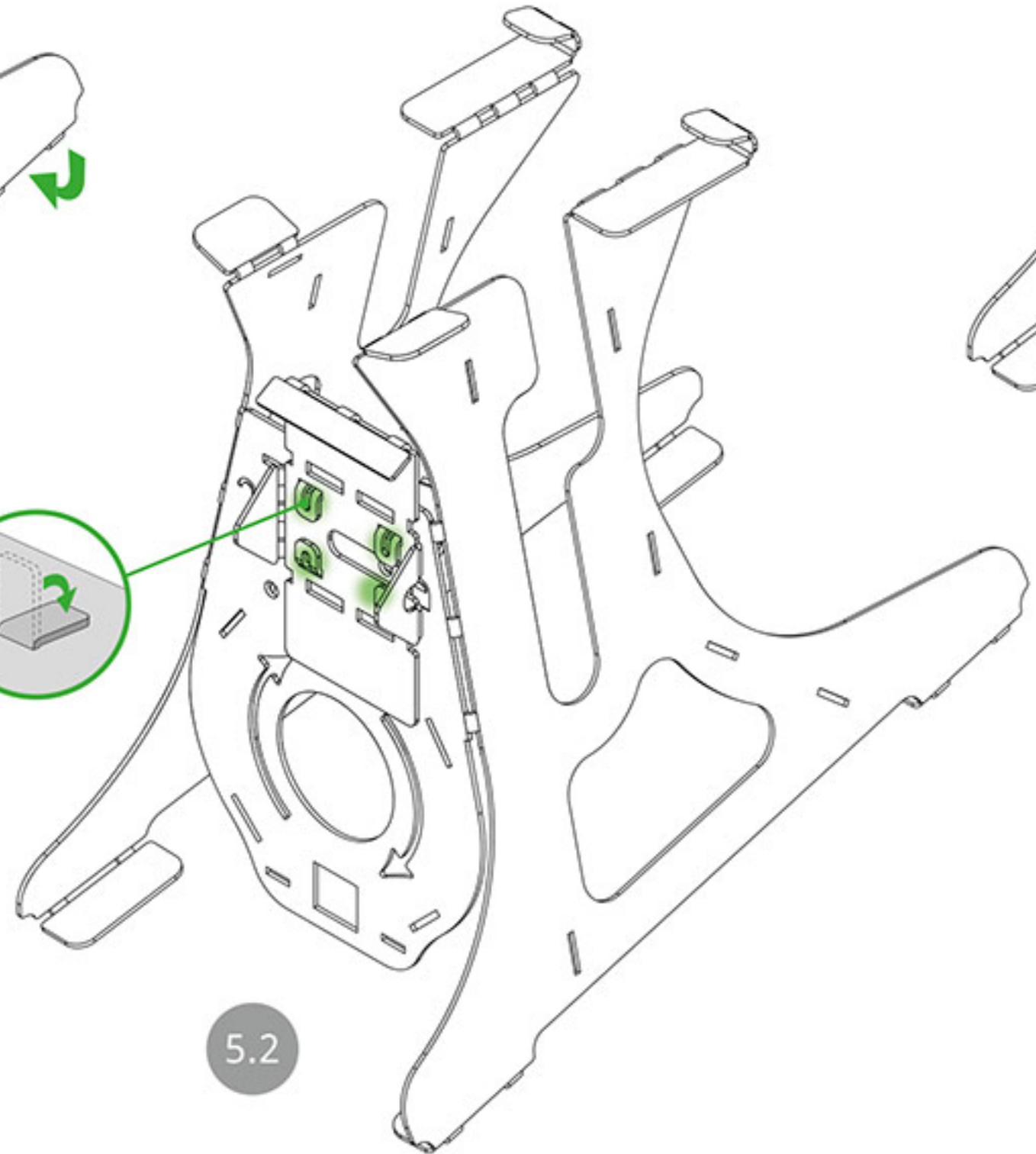

5.2

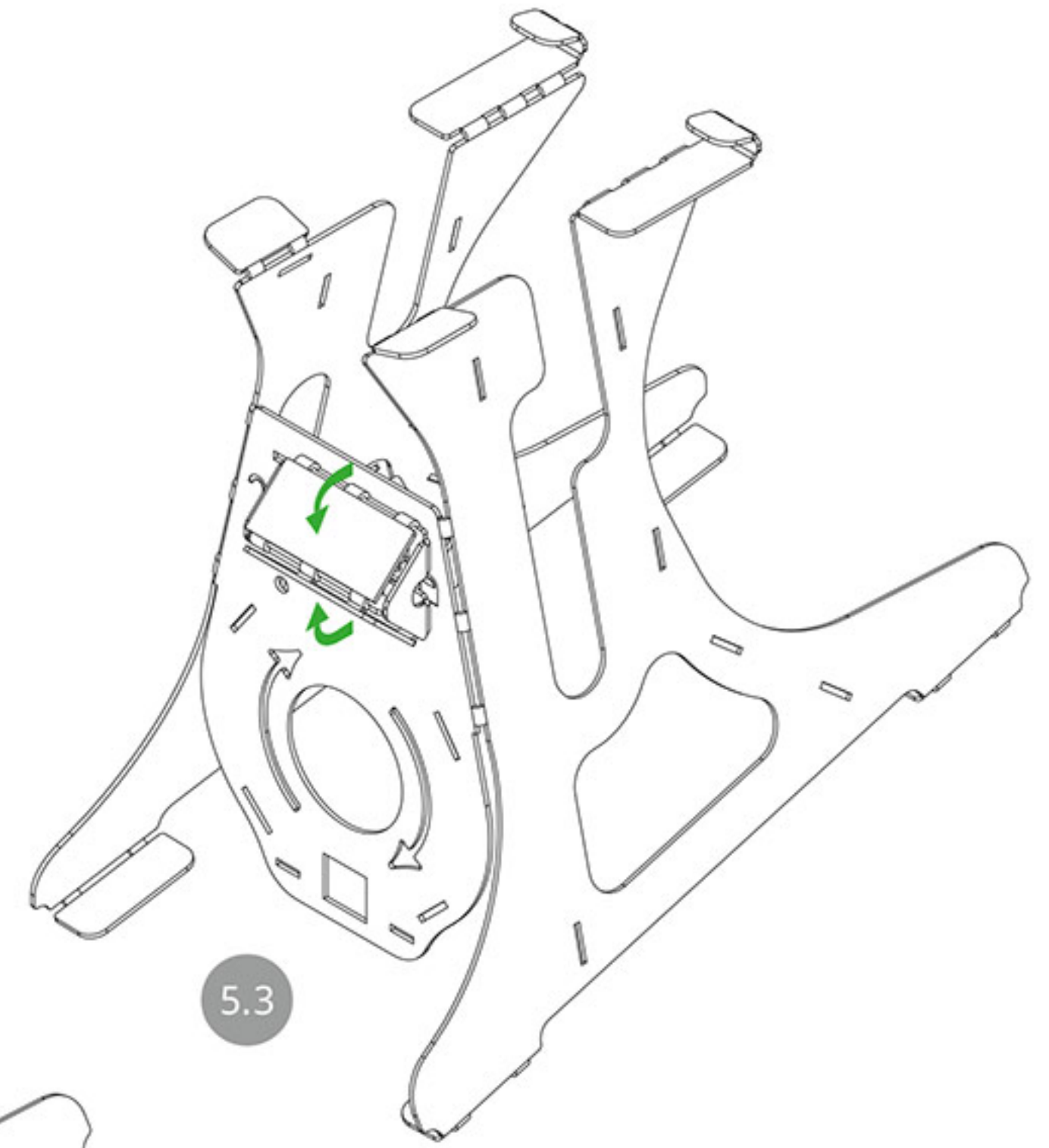

5.3



#3

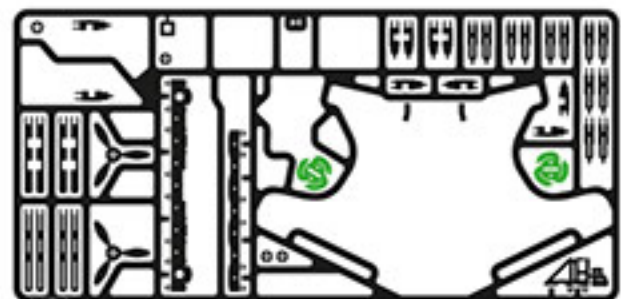

#4



G1



D2

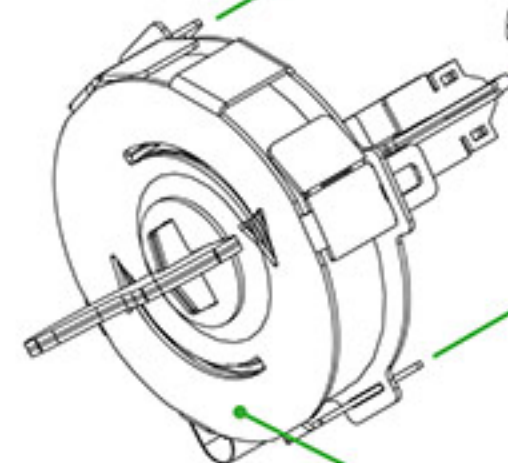

Assembly step 1

6.1

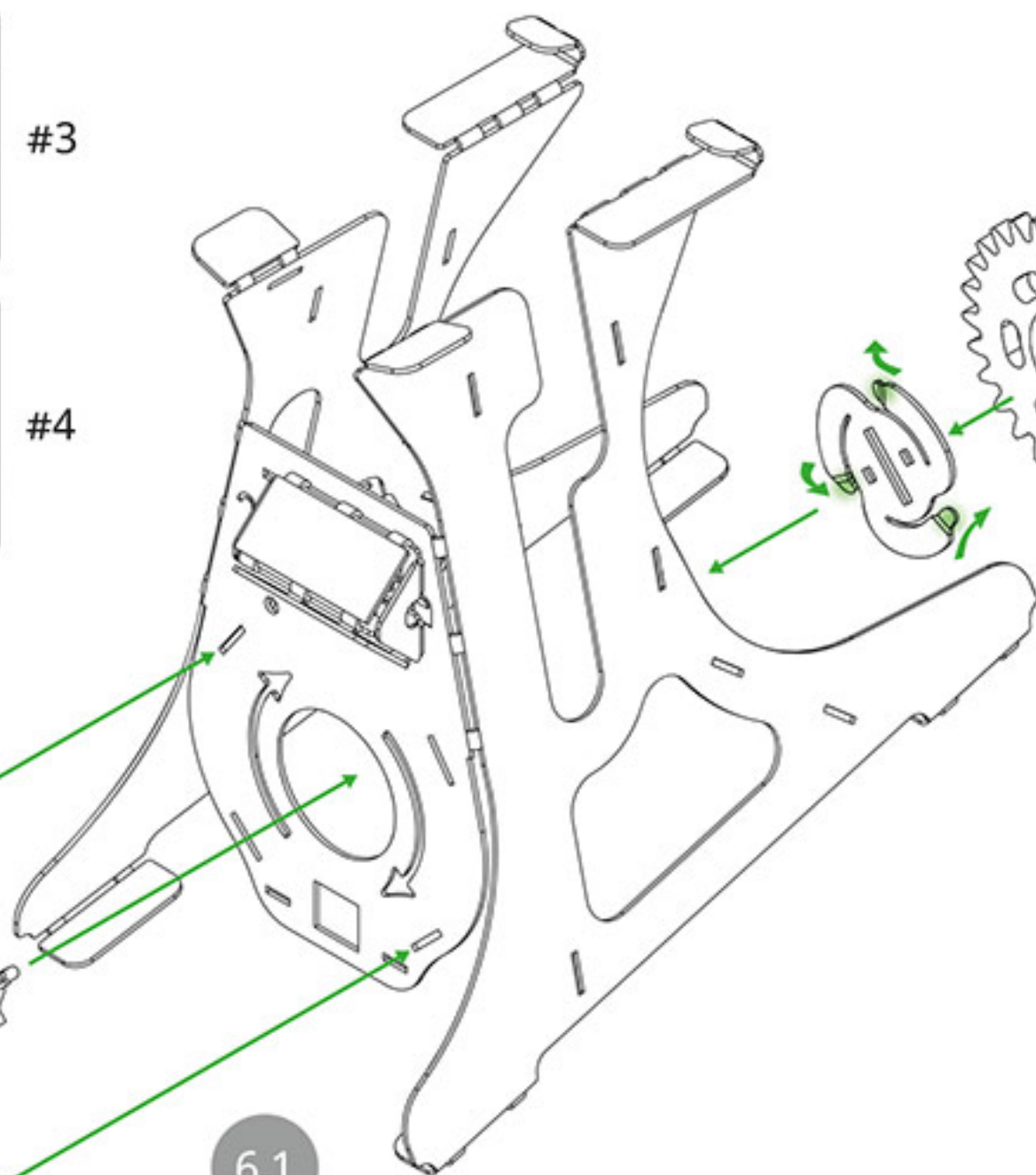

6.2

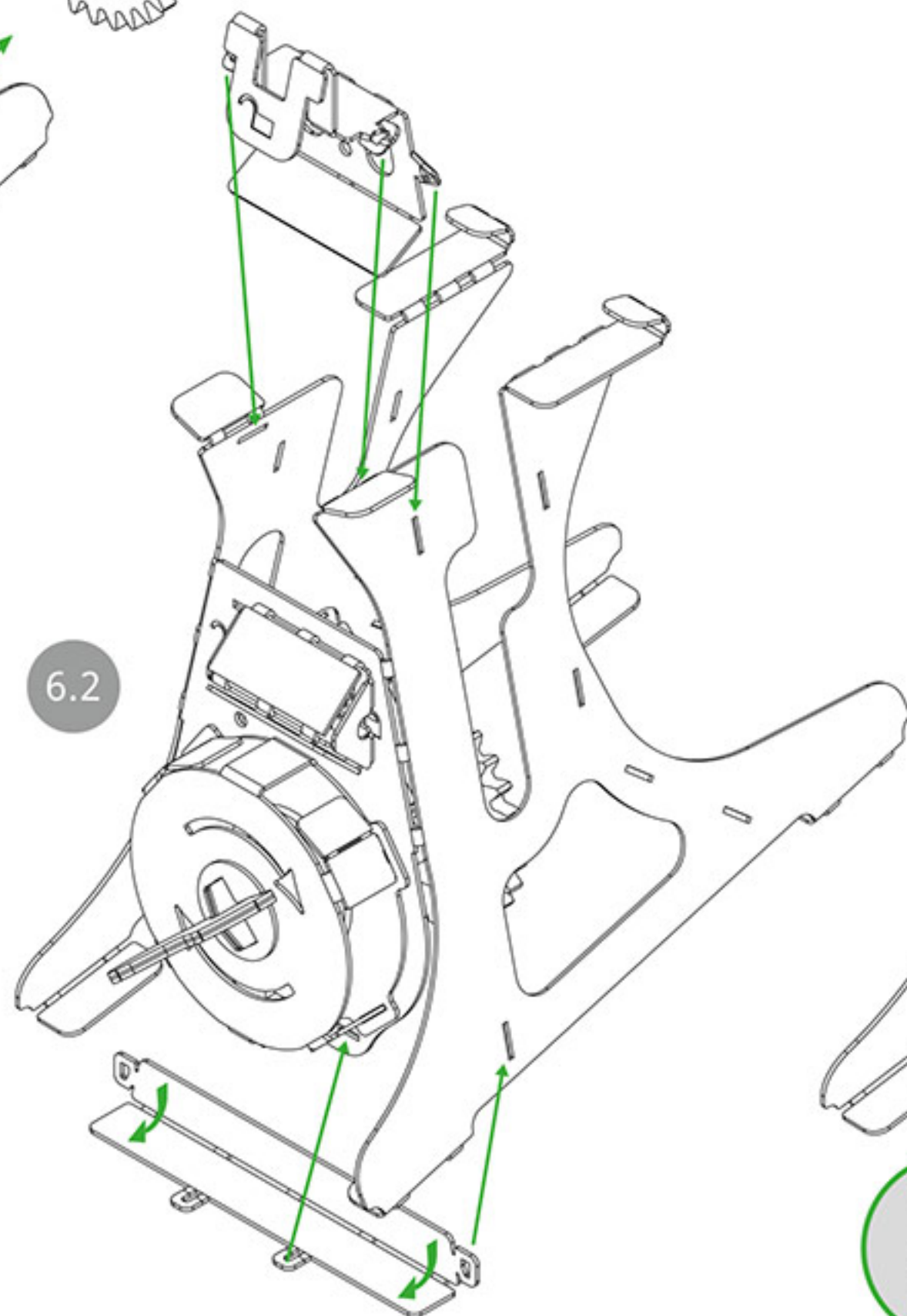

6.3

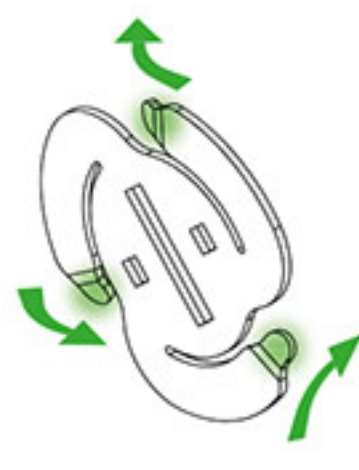
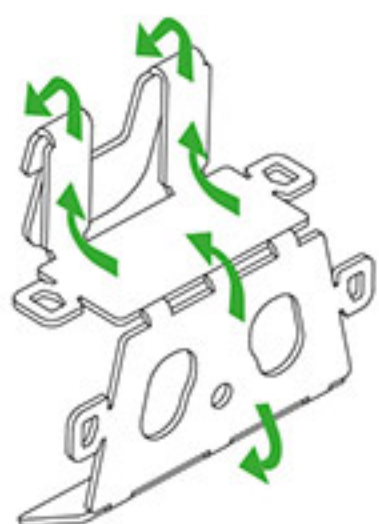
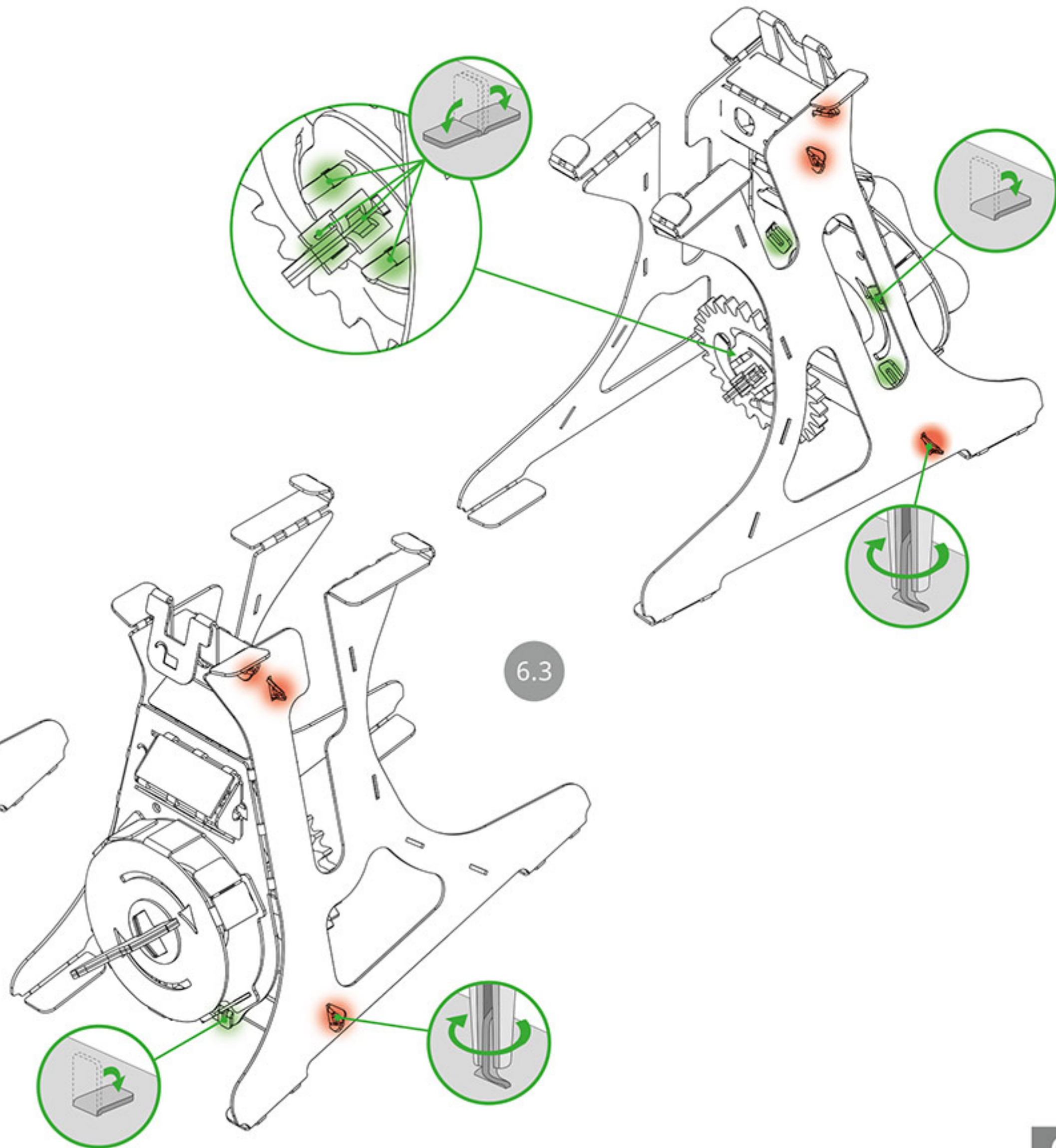



#3

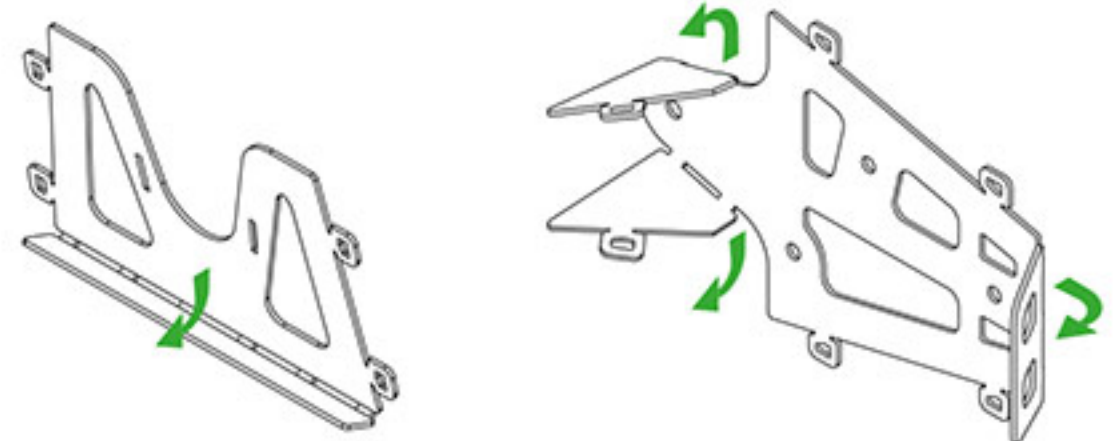

Assembly step 2

Assembly step 3

Assembly step 4

7.1

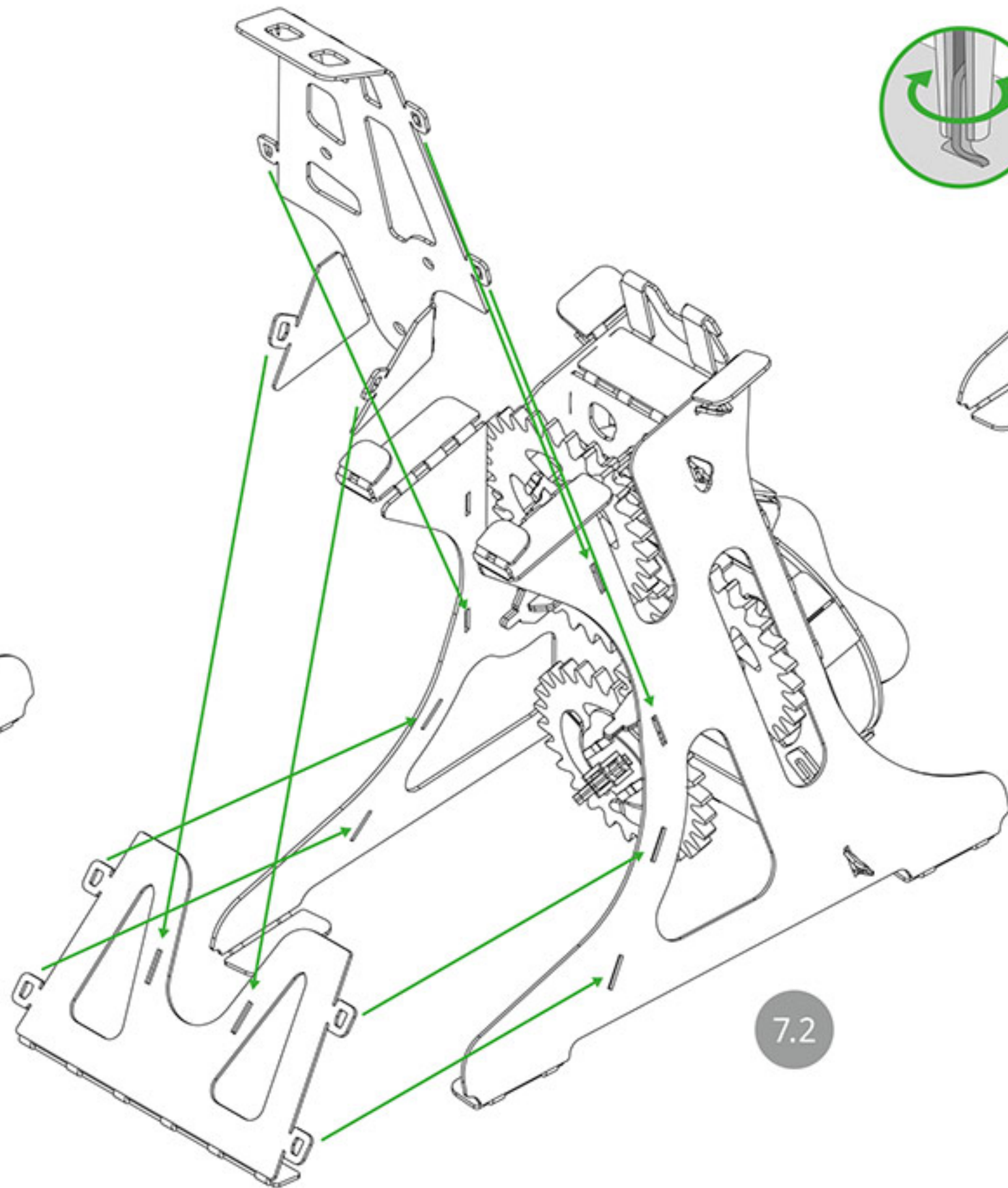

7.2

7.3

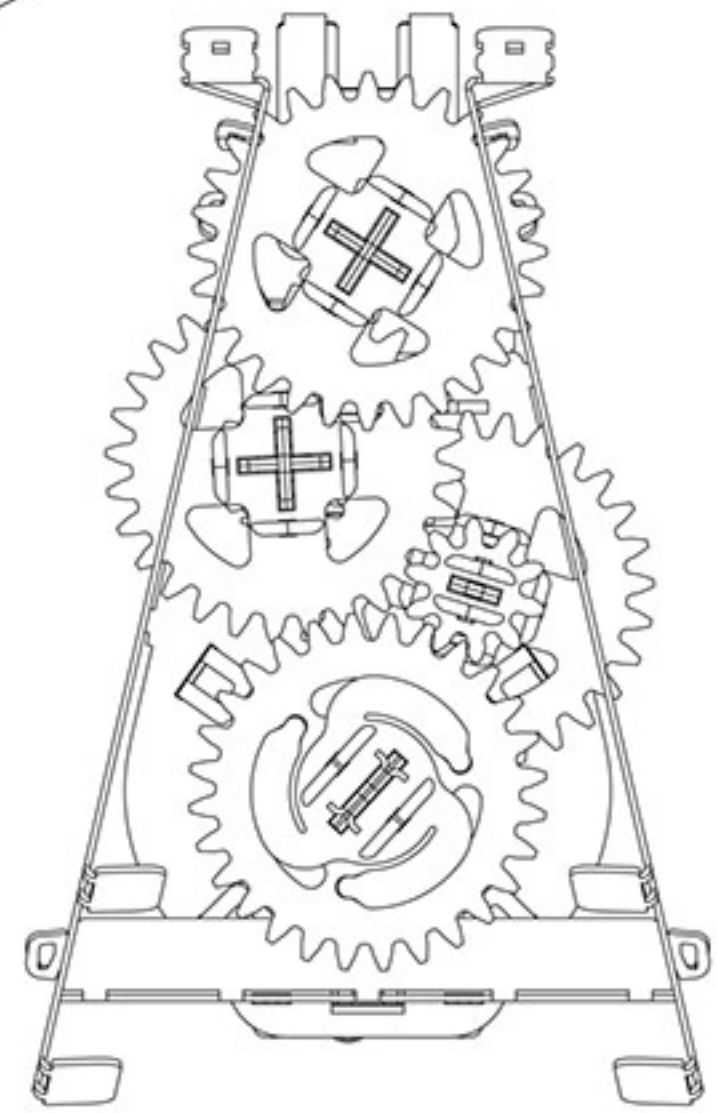



#1

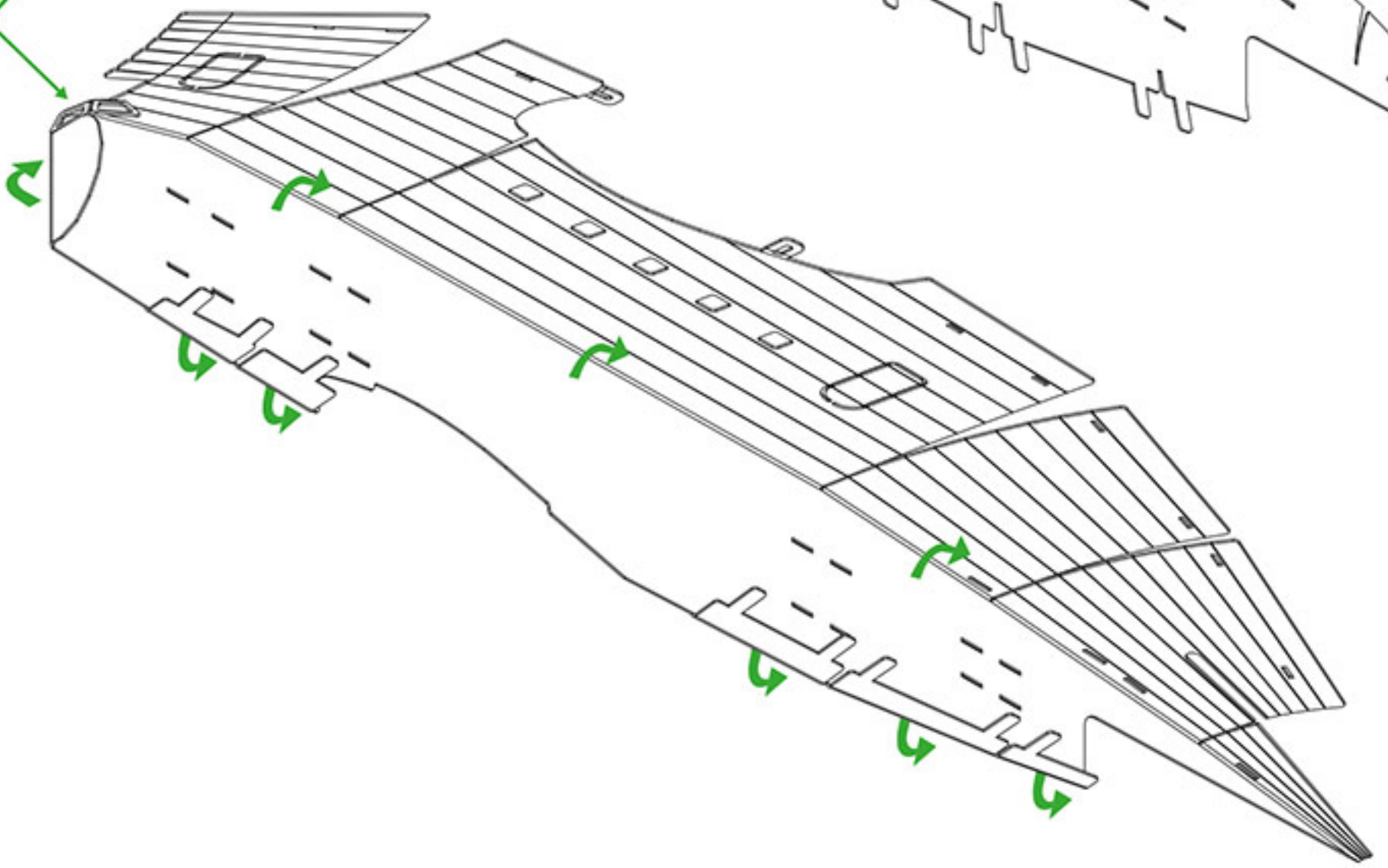
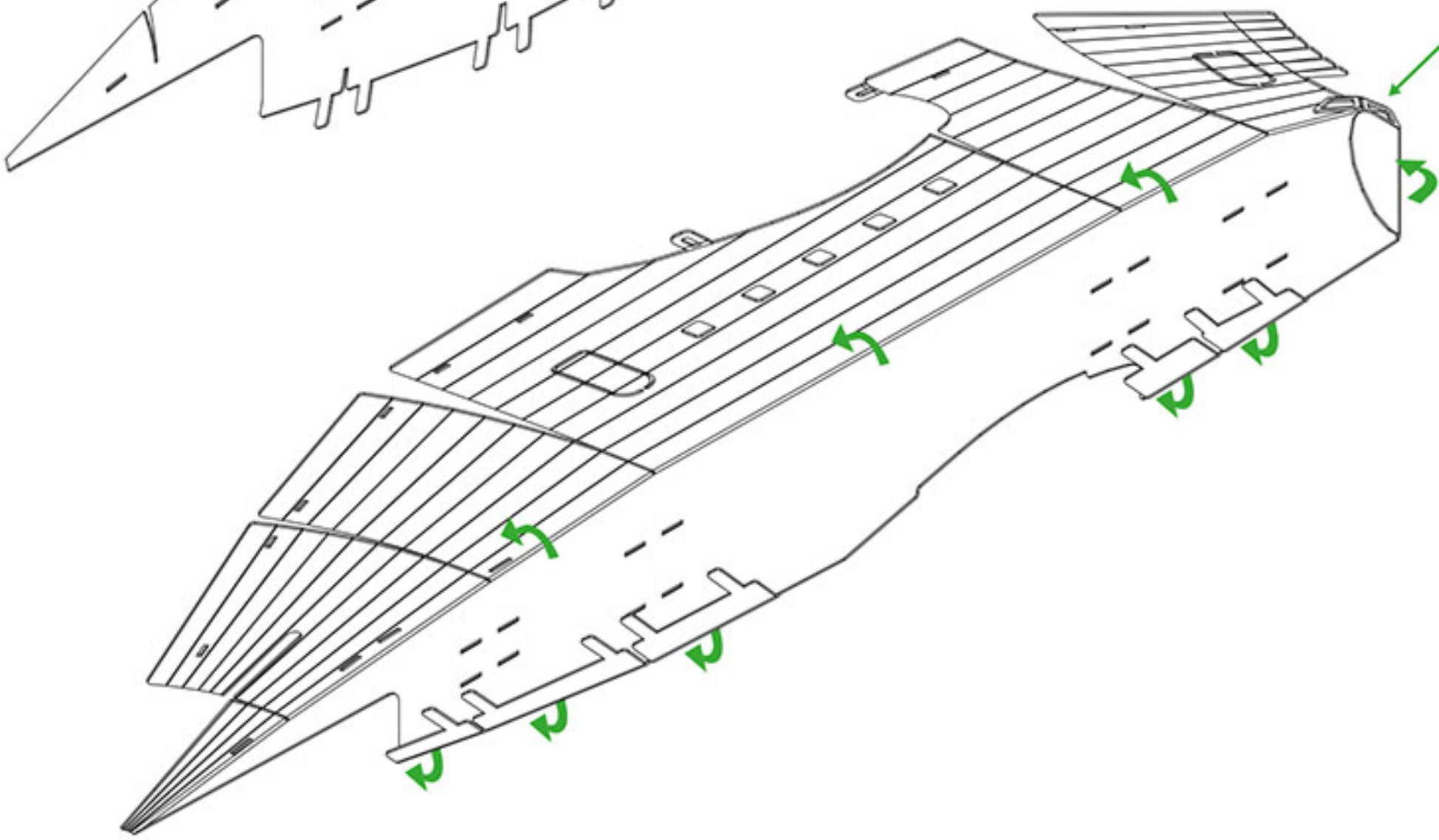
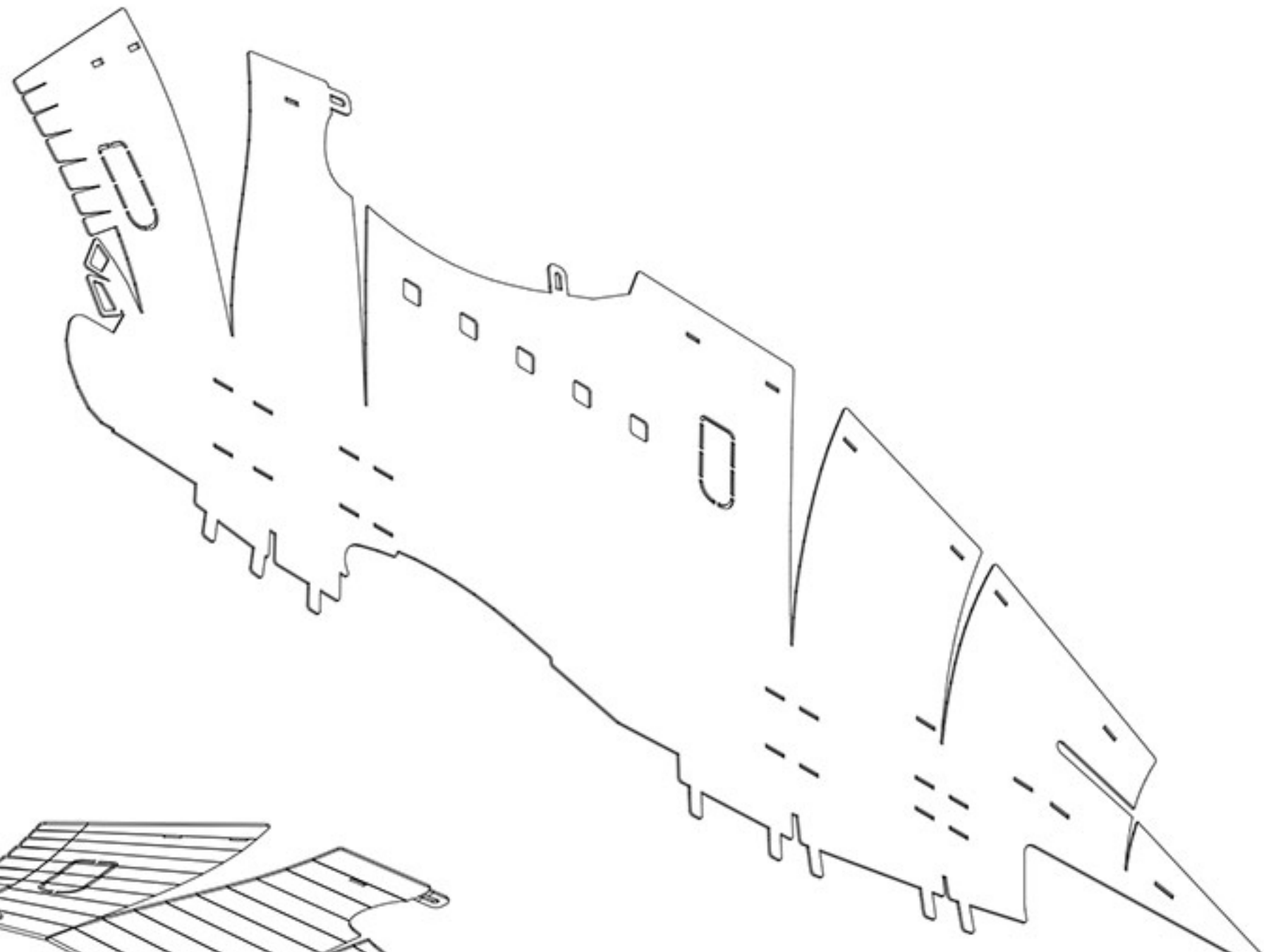
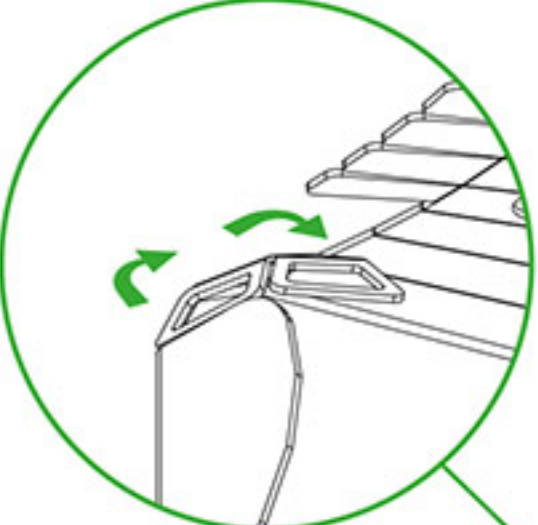
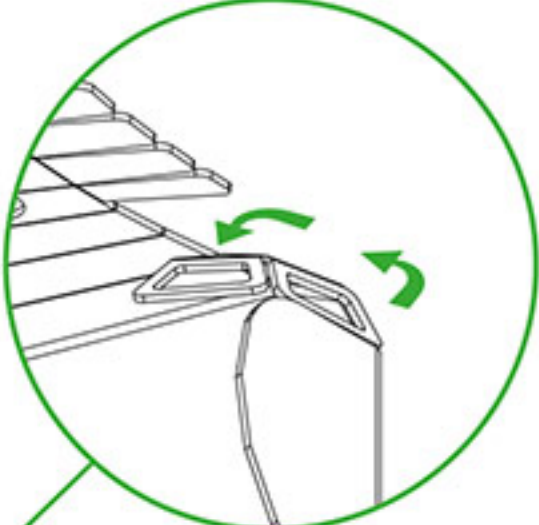
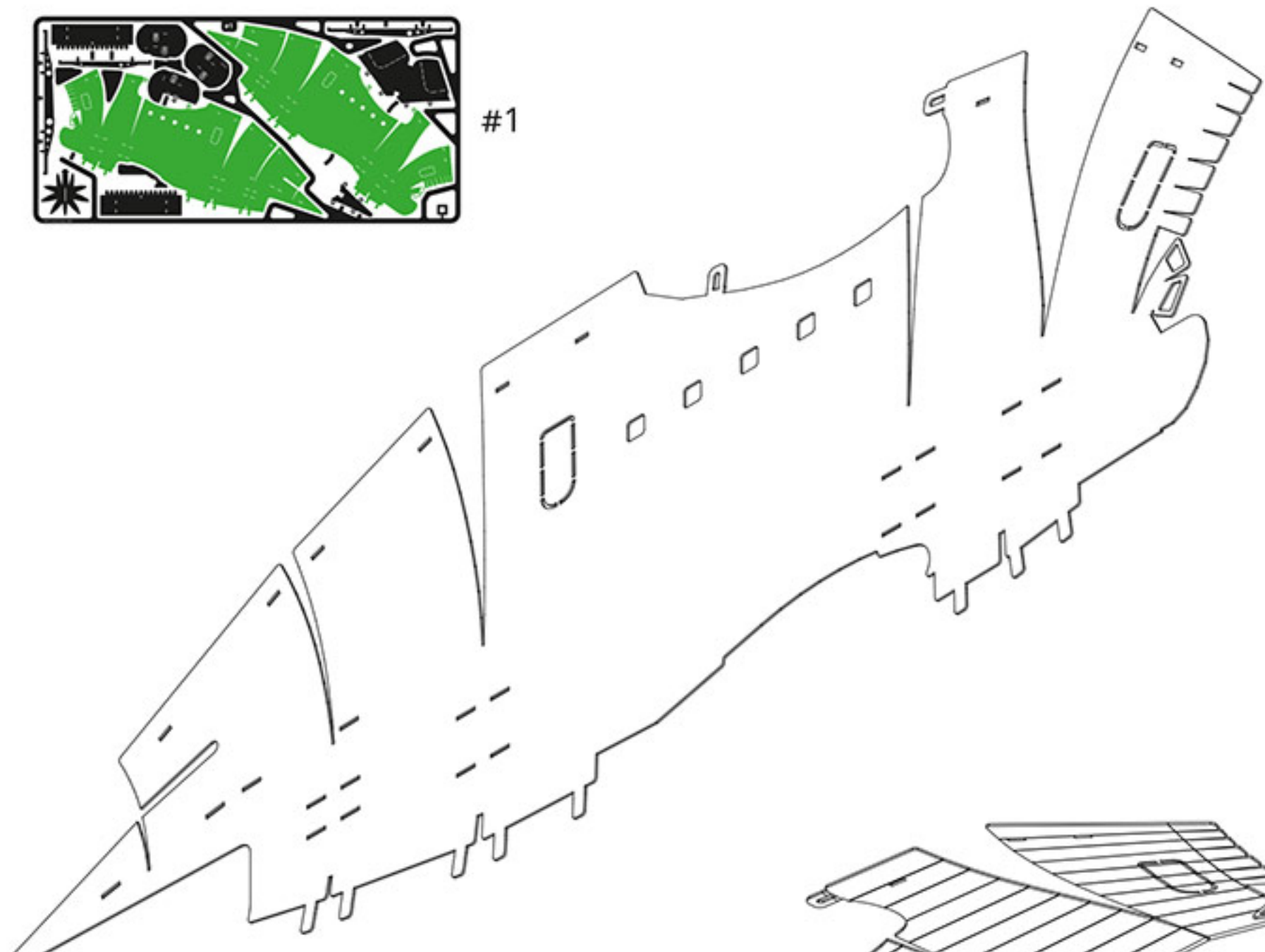



#1

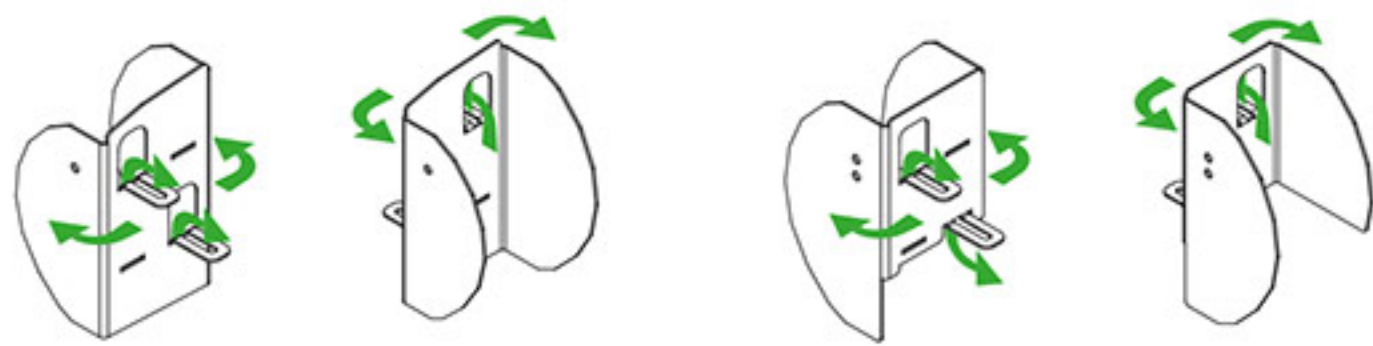

#2

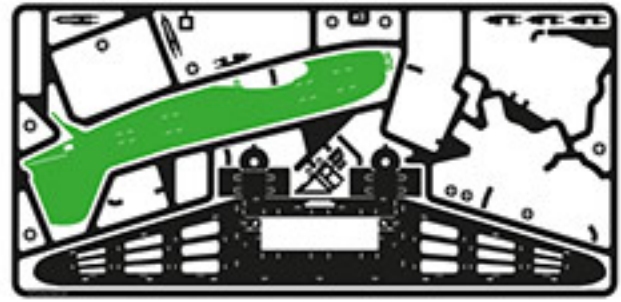
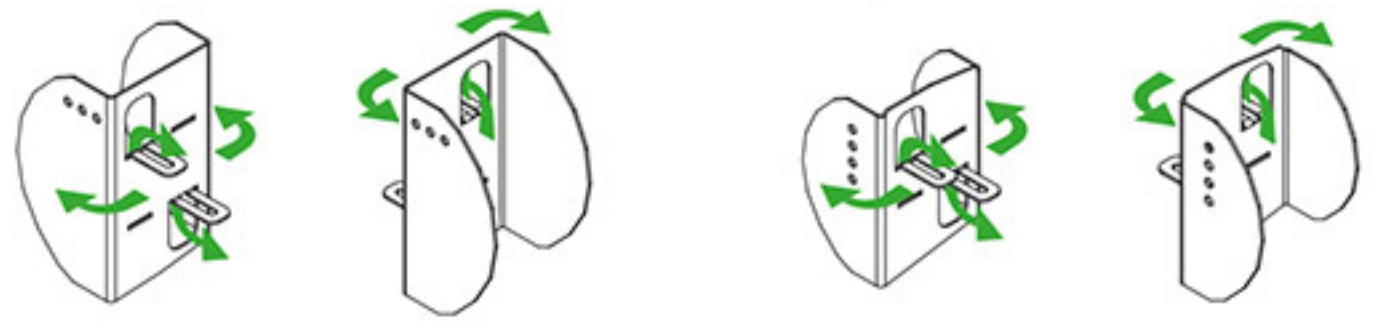

#3

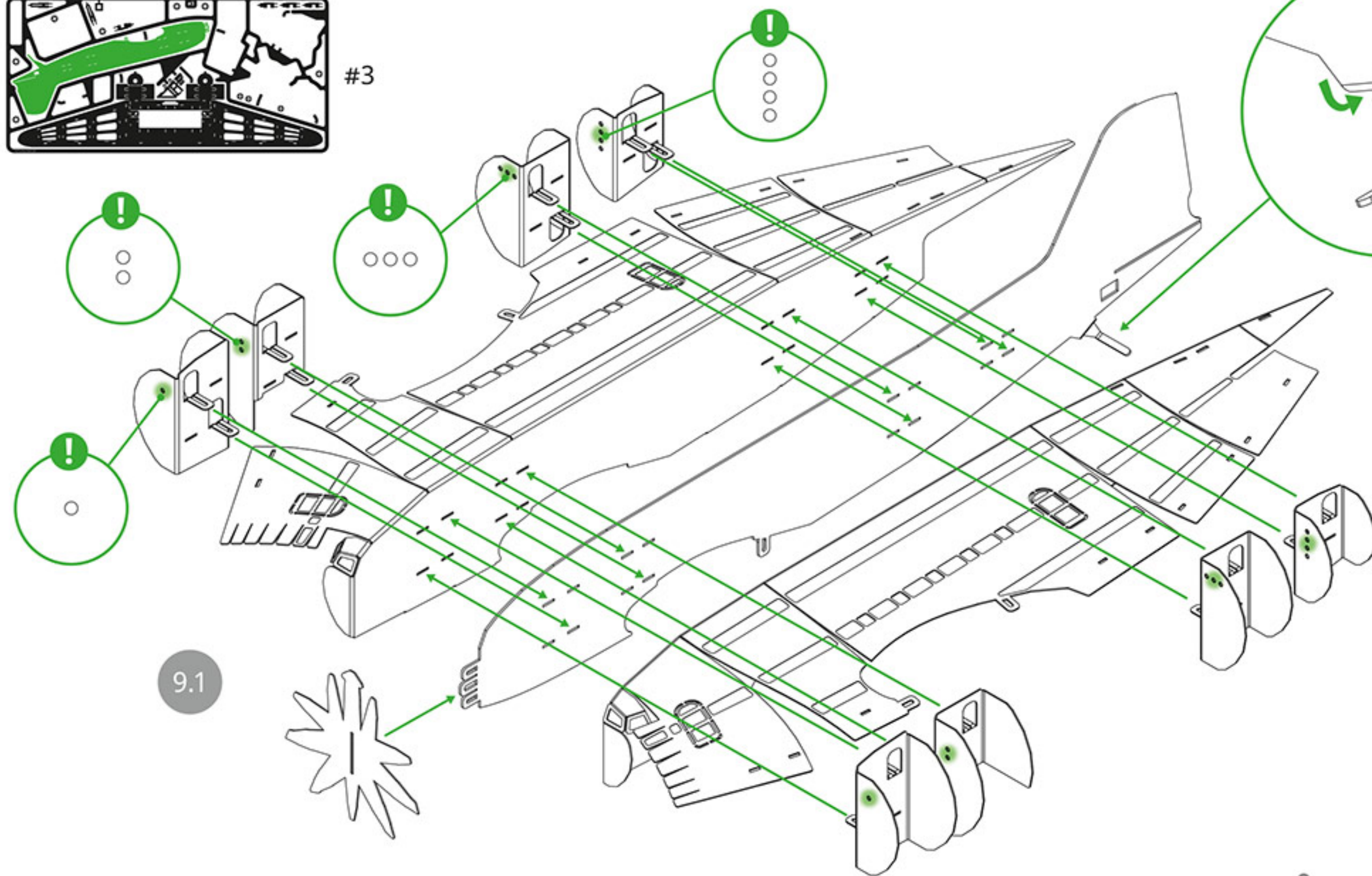

9.1

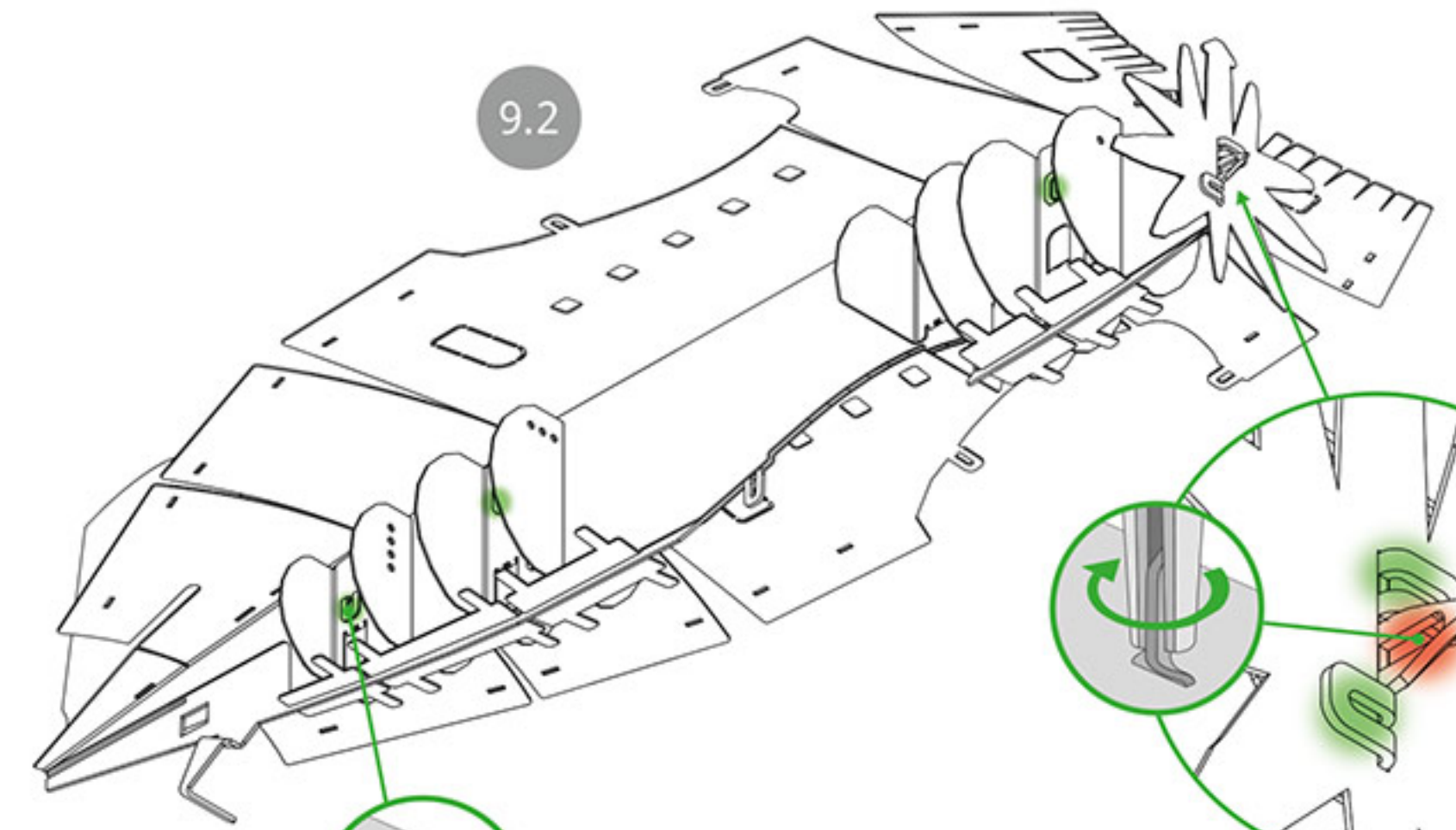

9.2

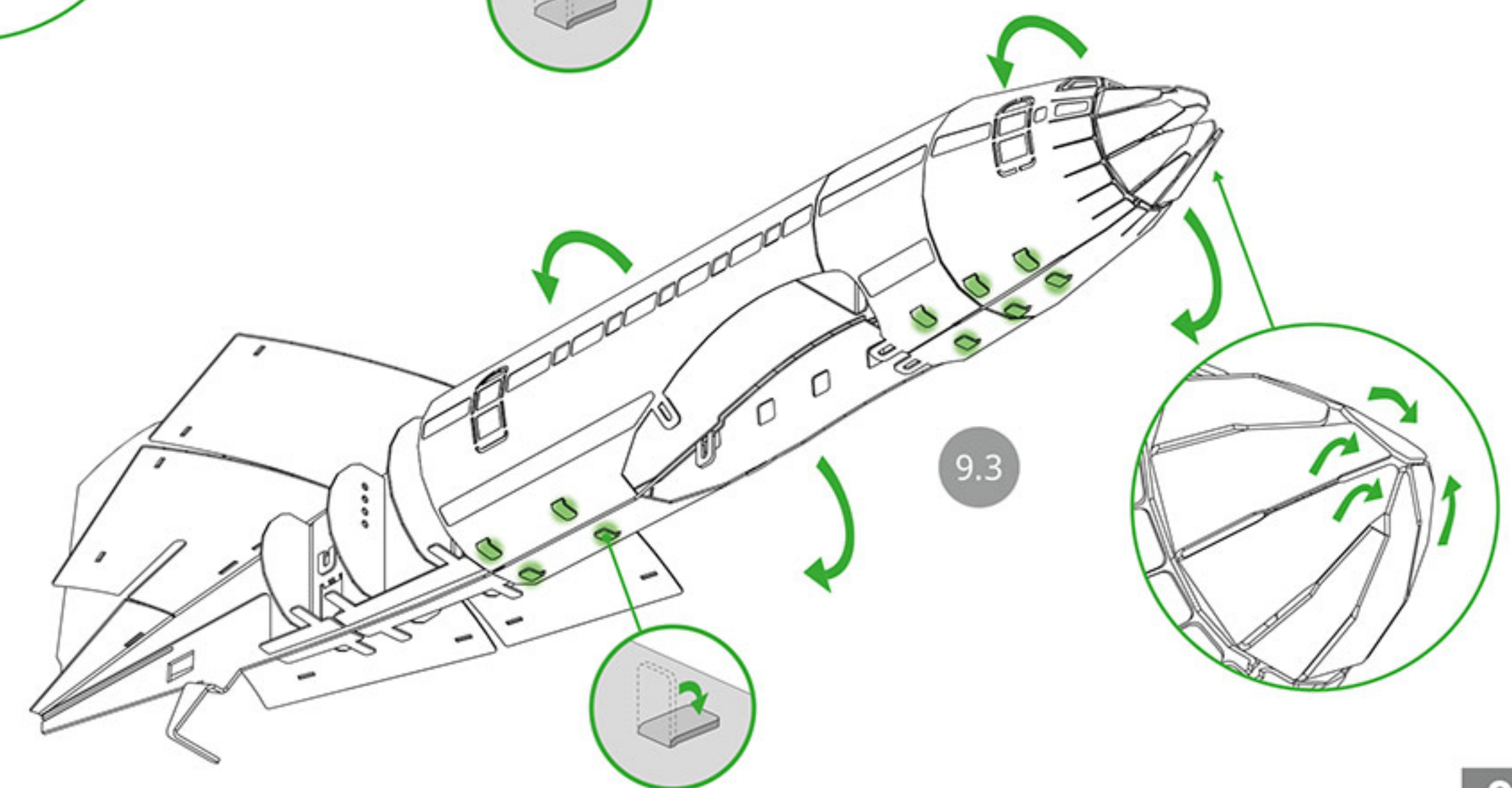

9.3

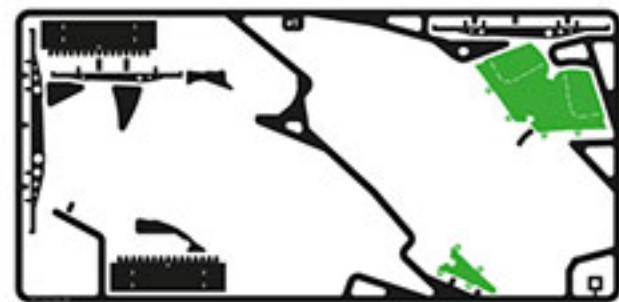

#1



#2

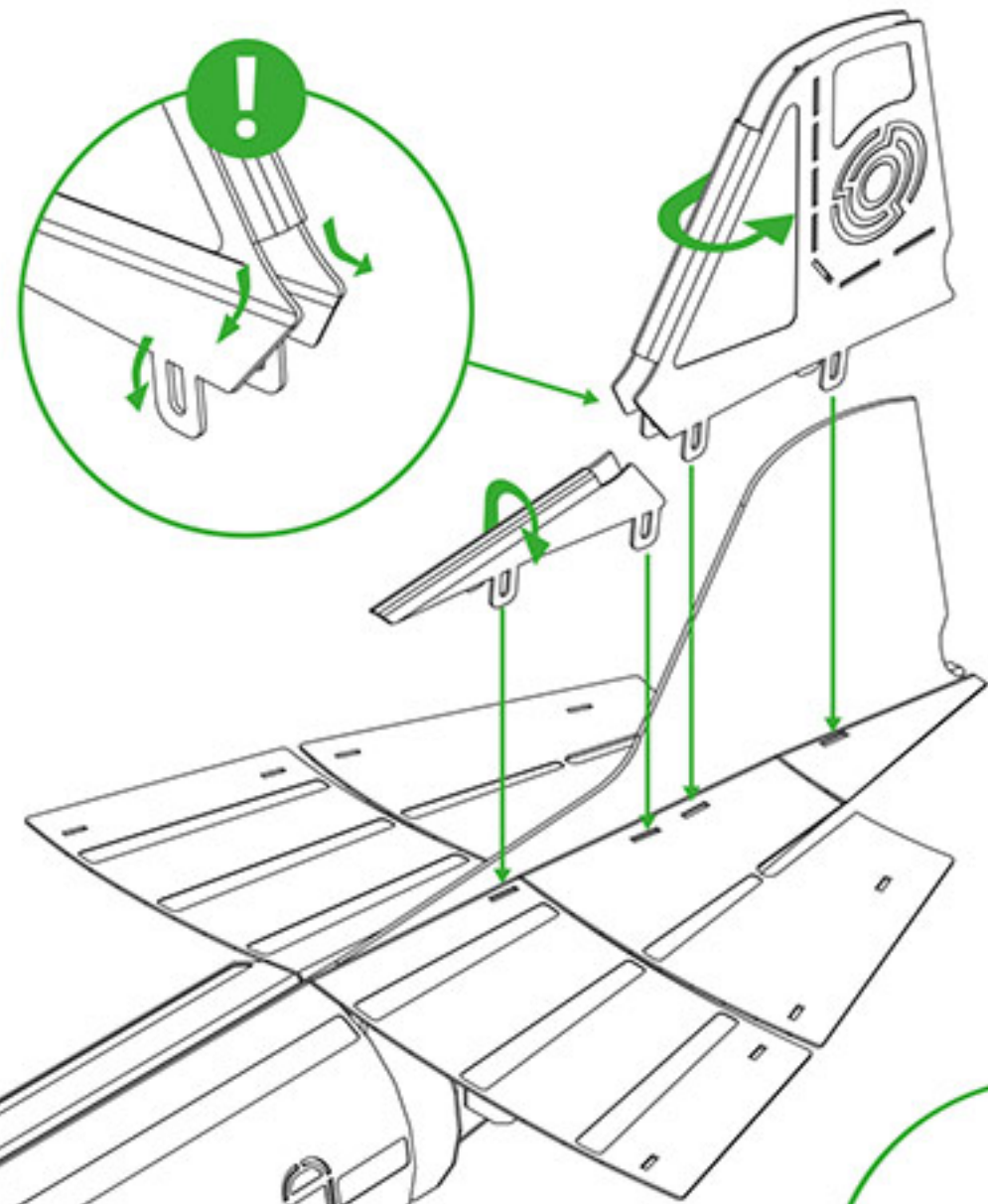

10.1

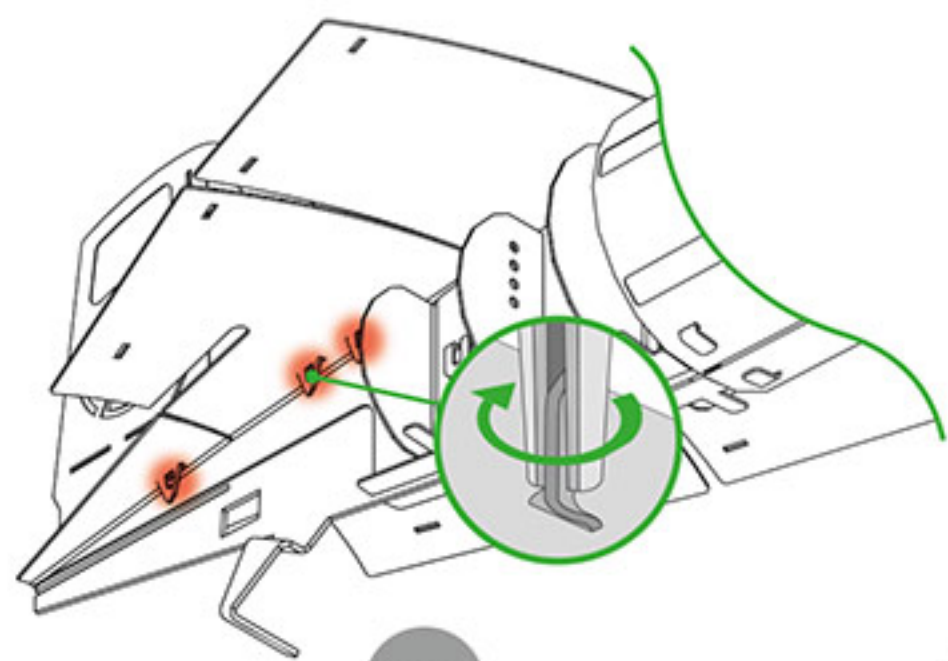

10.3

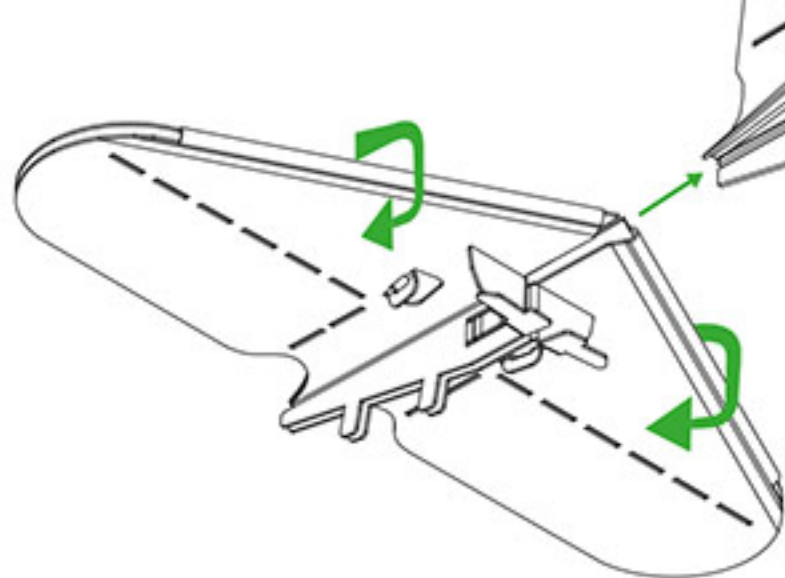

10.4

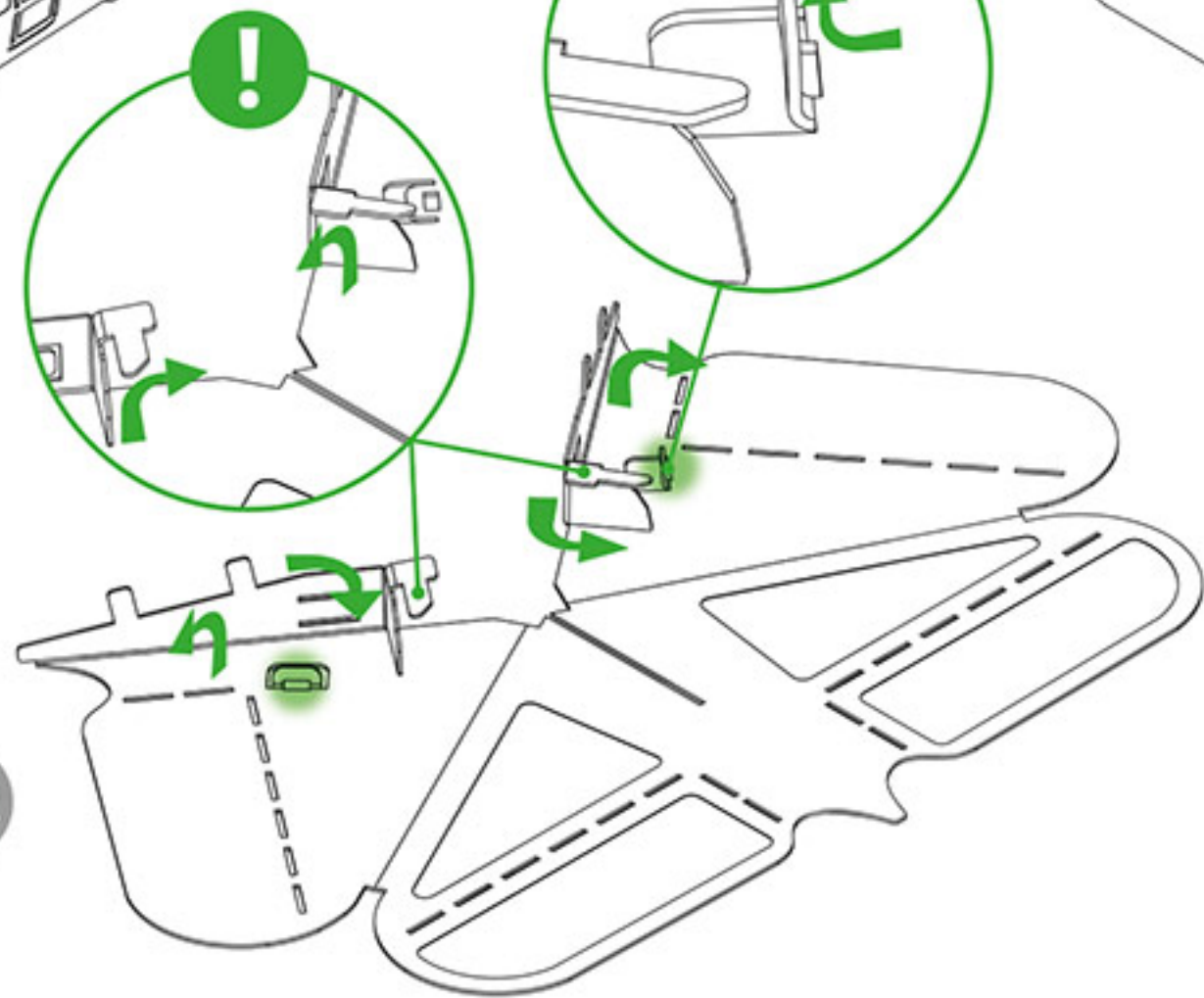

10.2

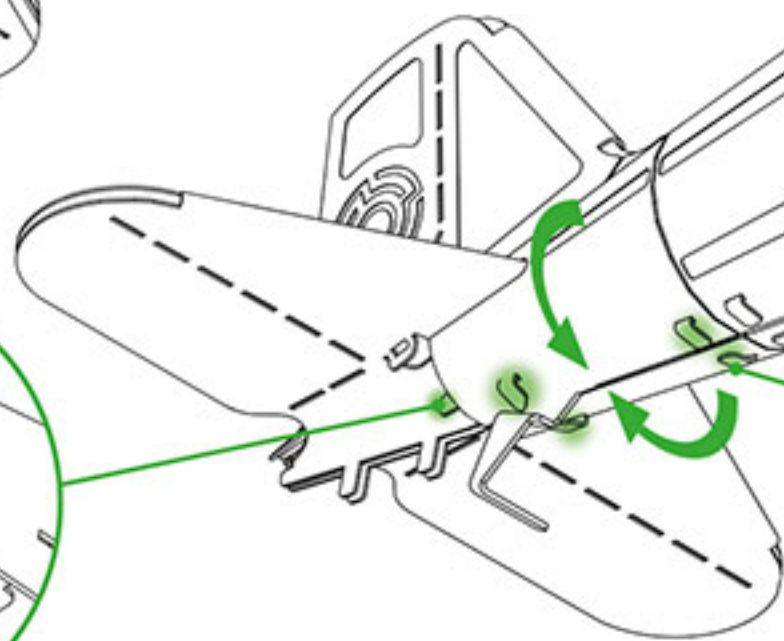
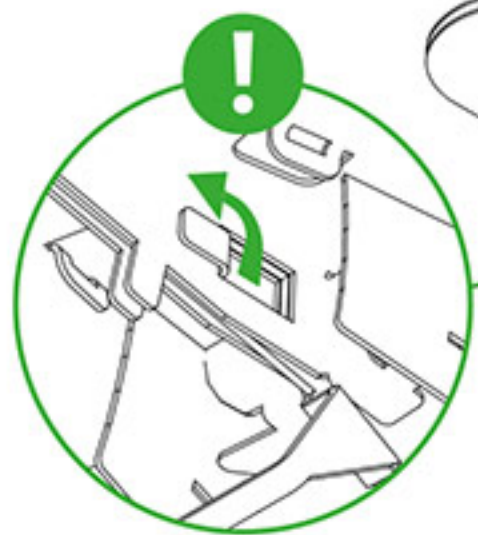

10.5

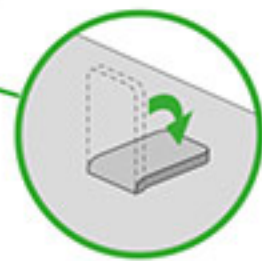



#2

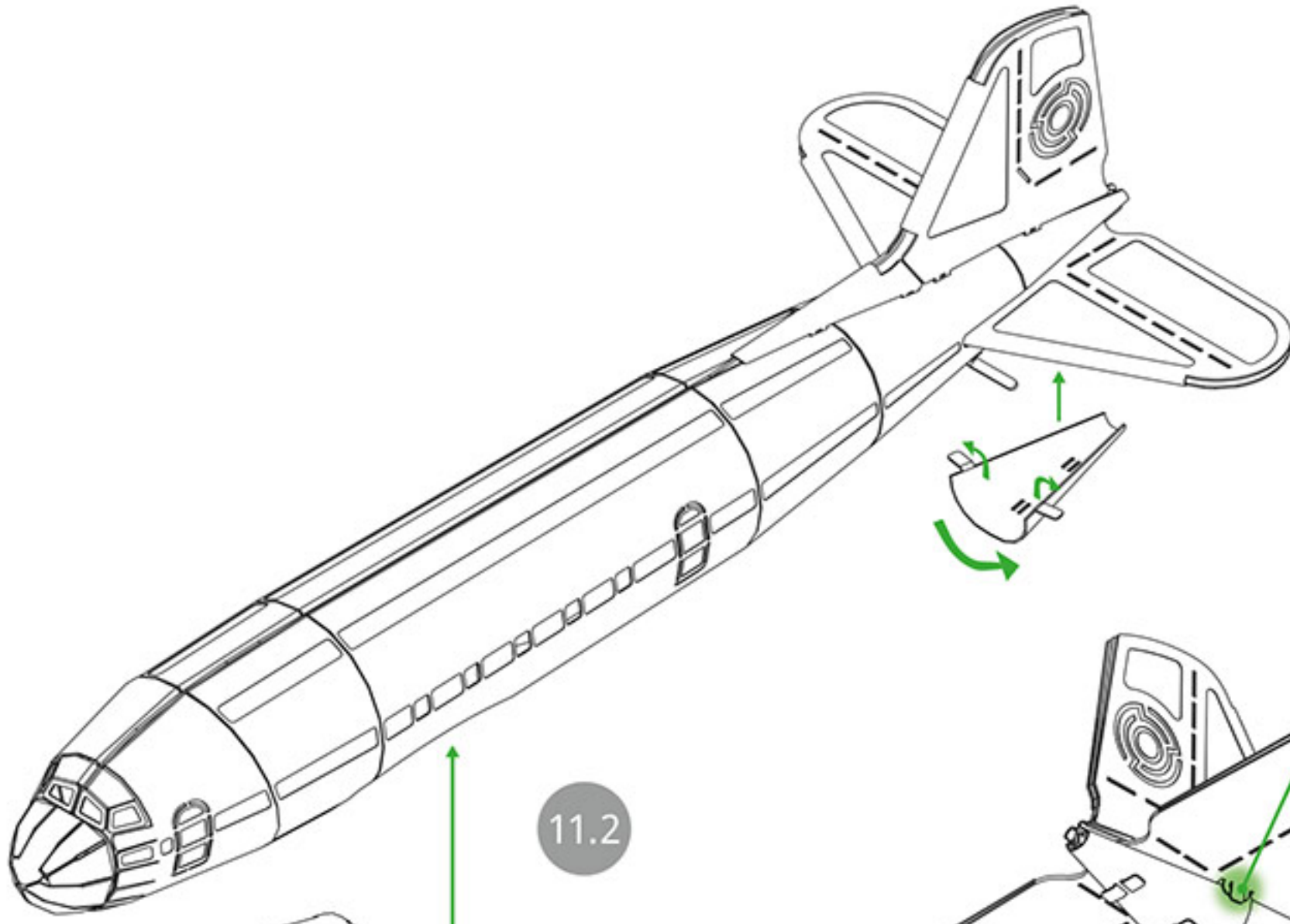
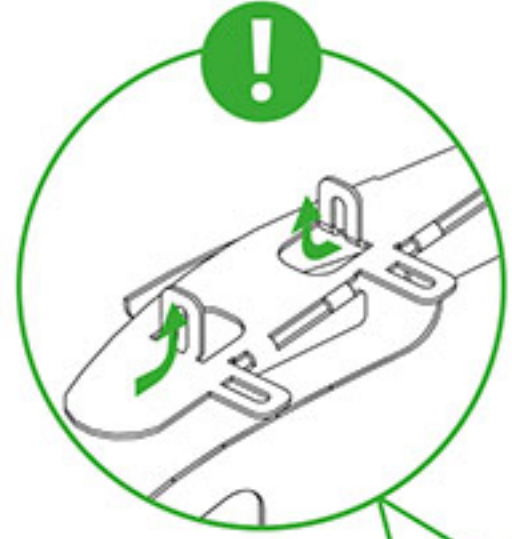

11.2

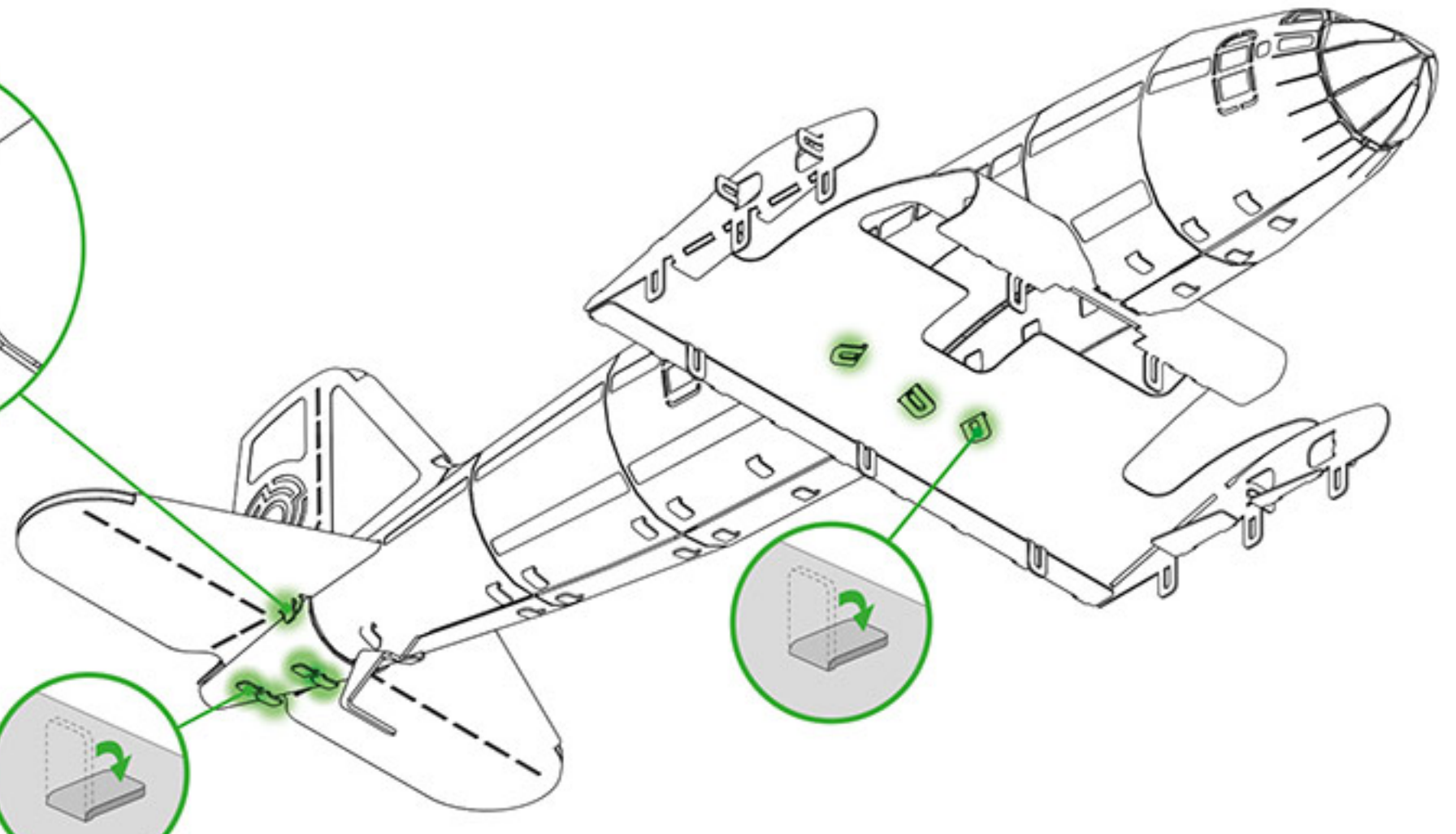
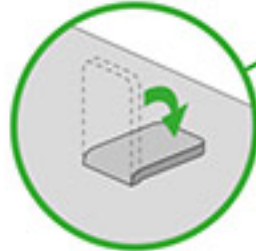
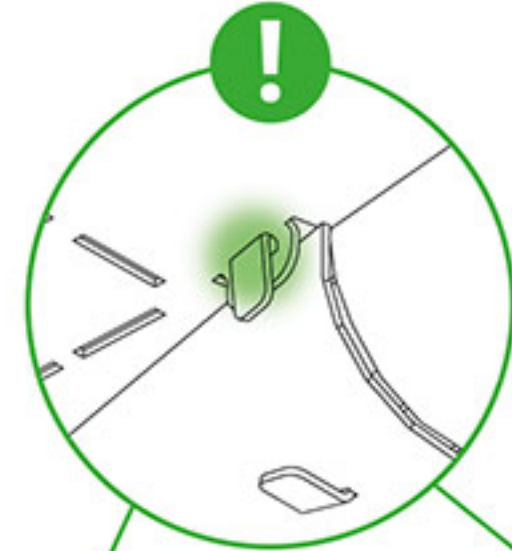

11.3

11.1

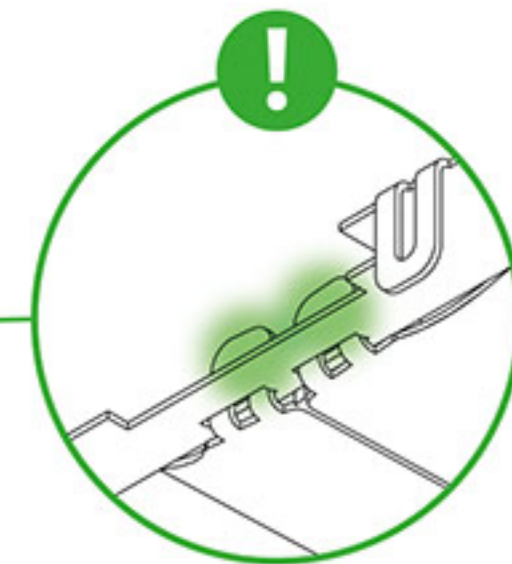
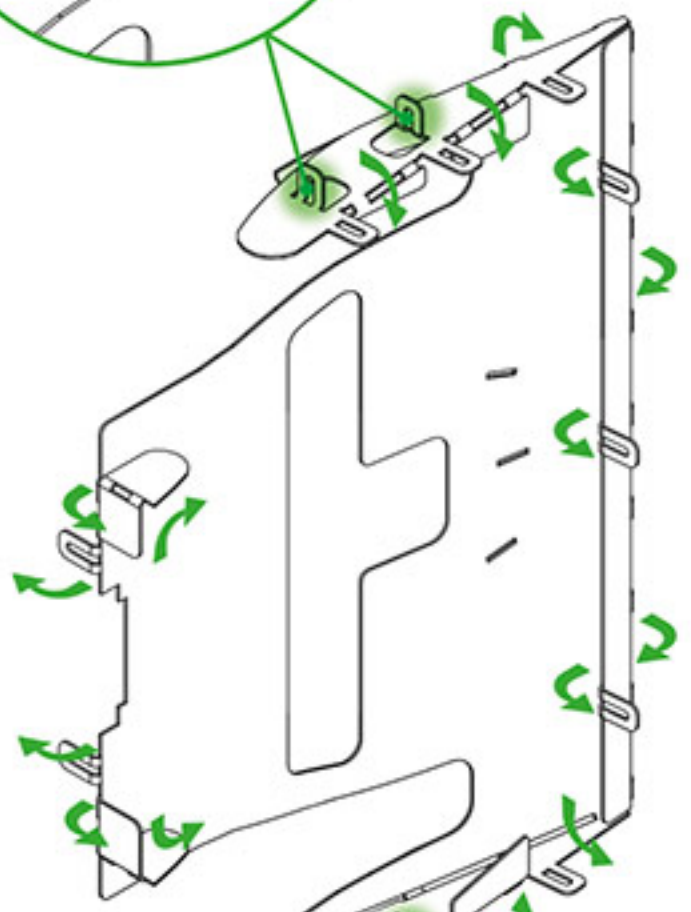



#2

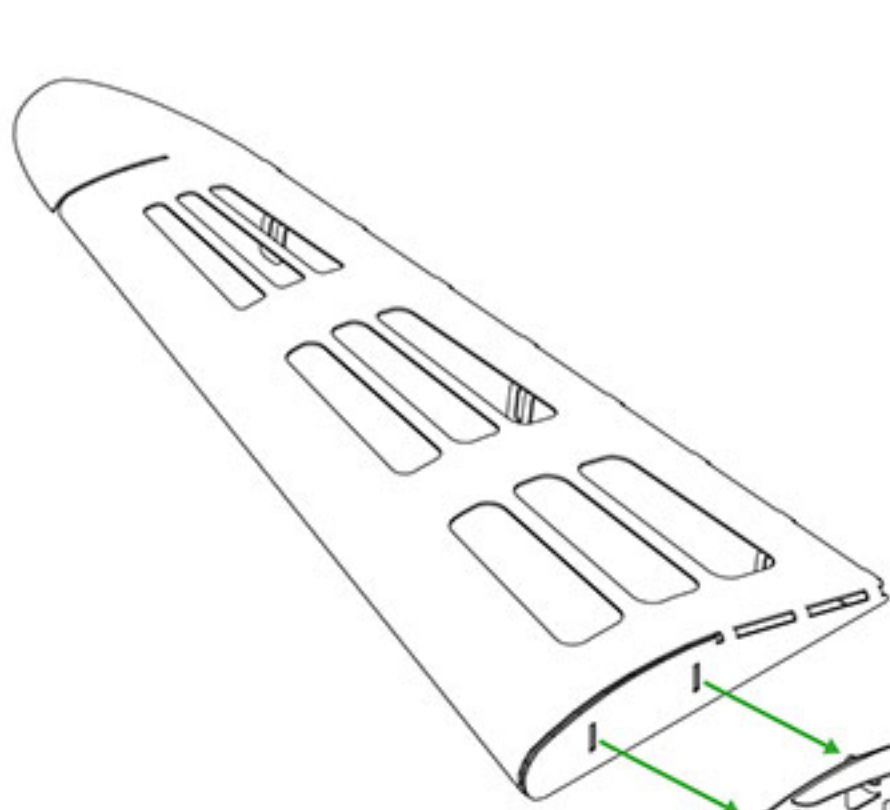

12.3

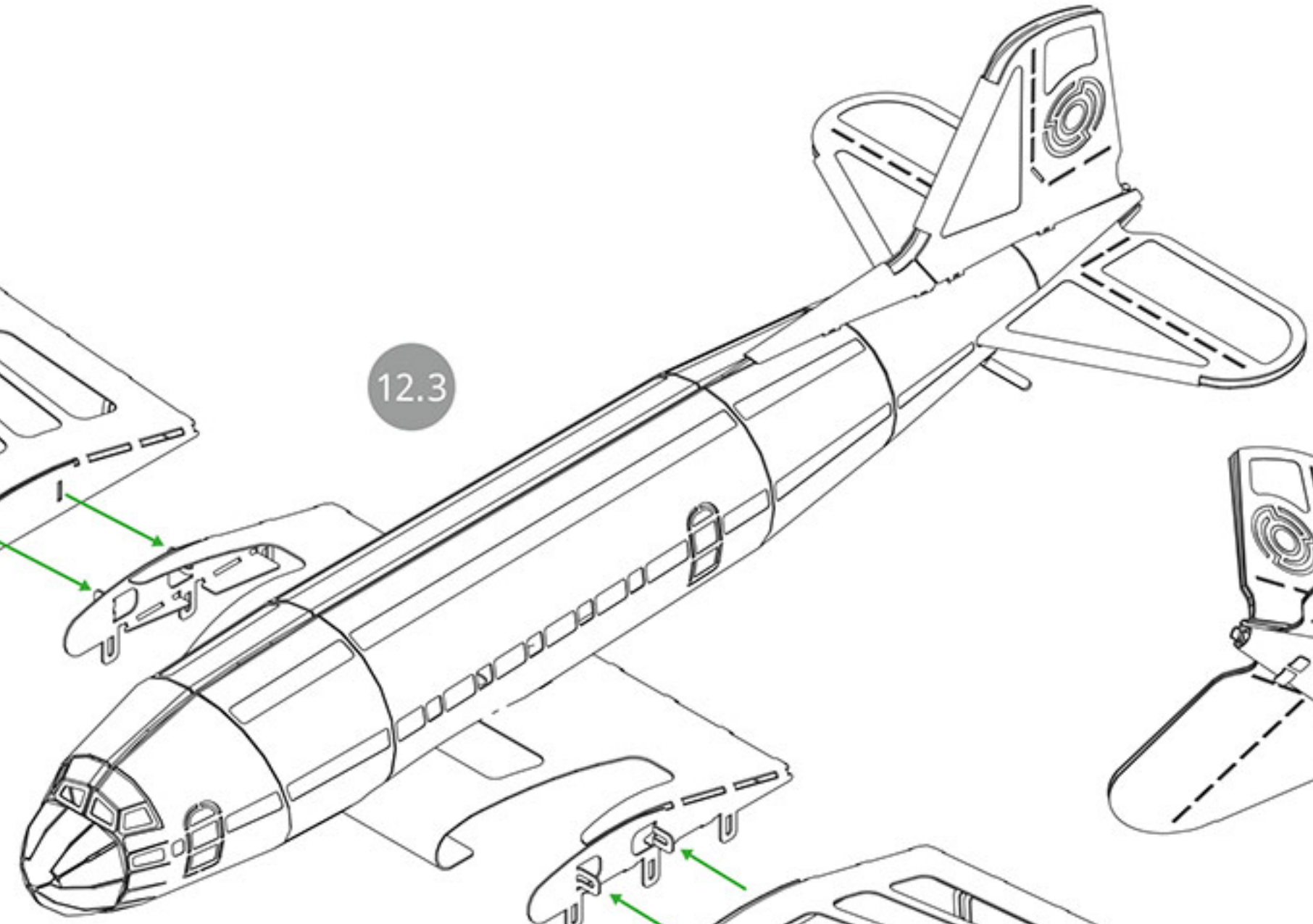

12.4

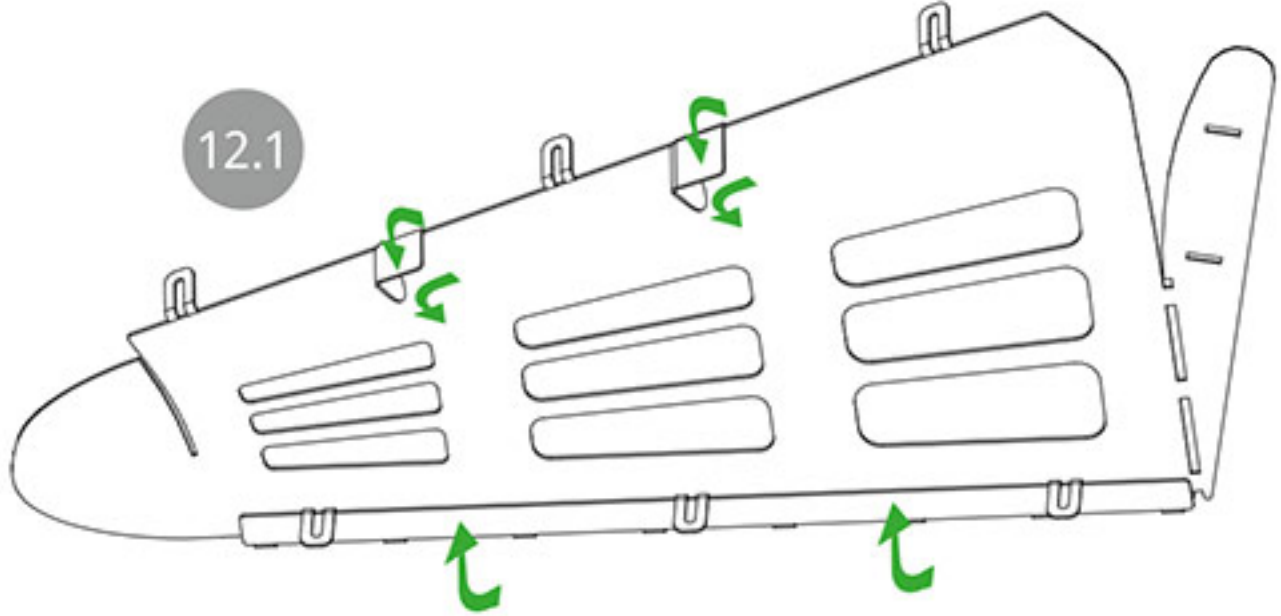
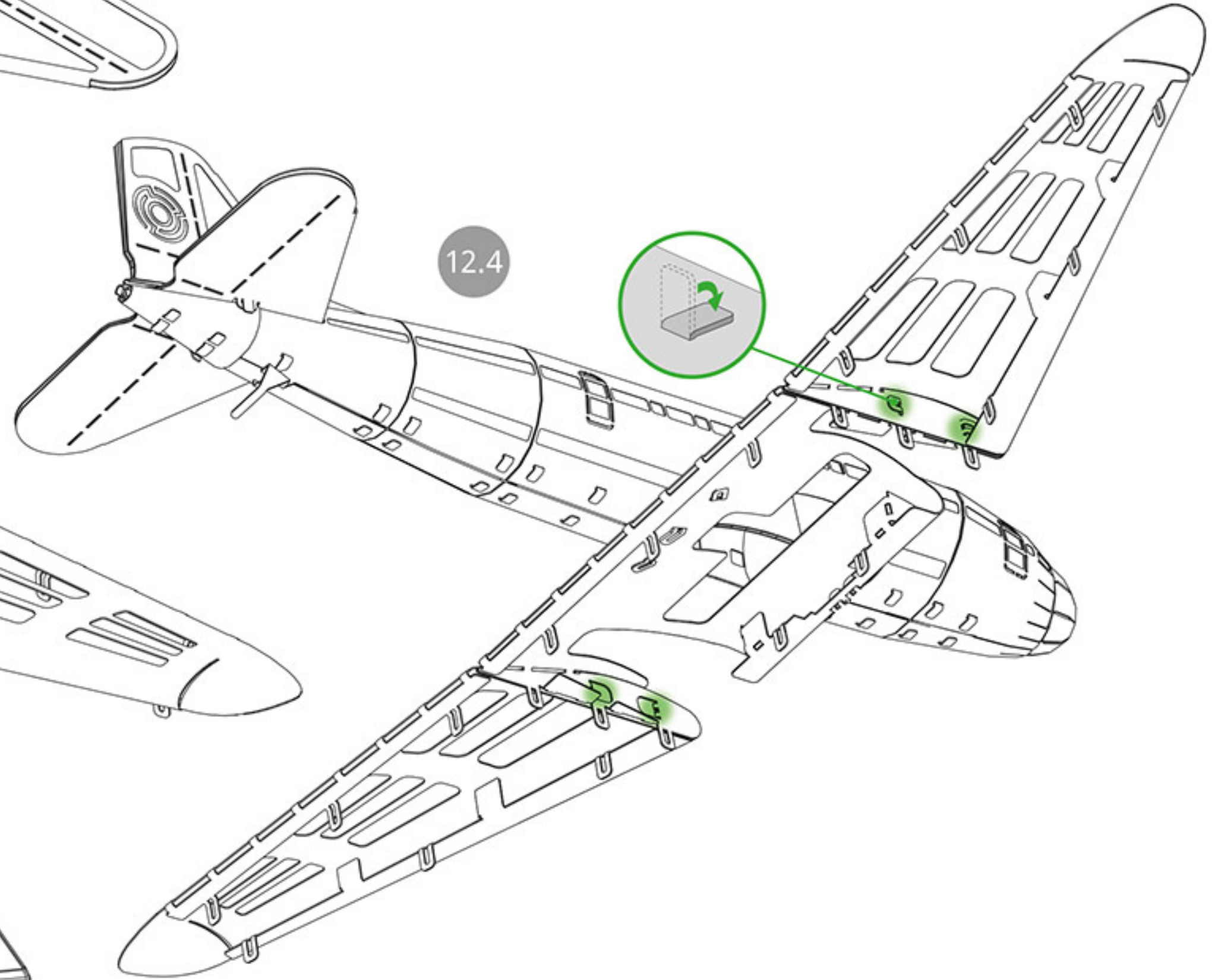

12.1

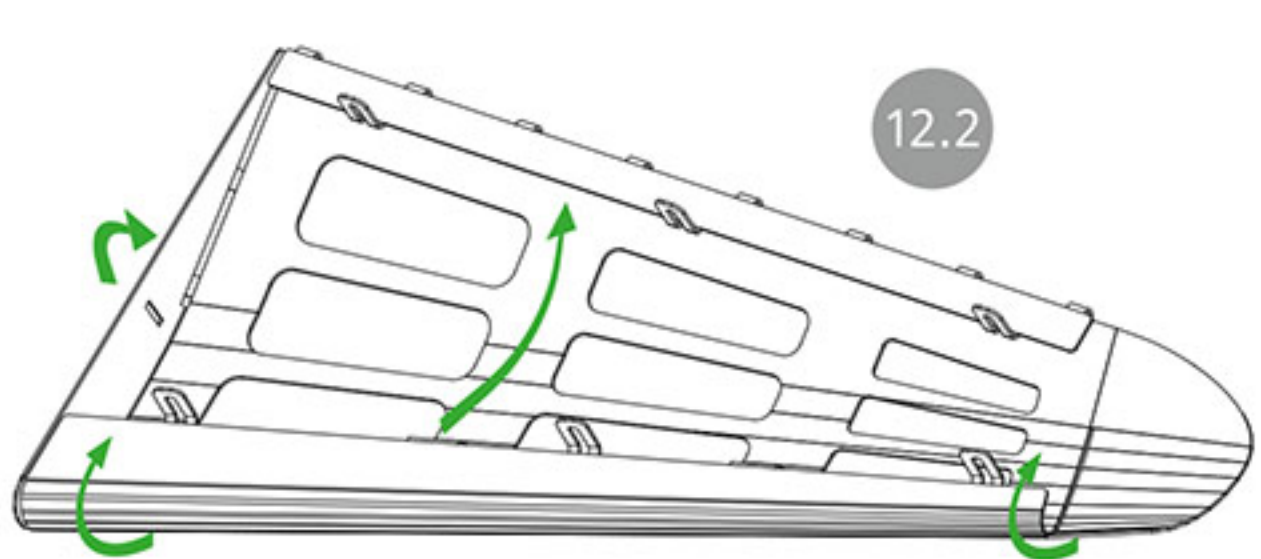

12.2

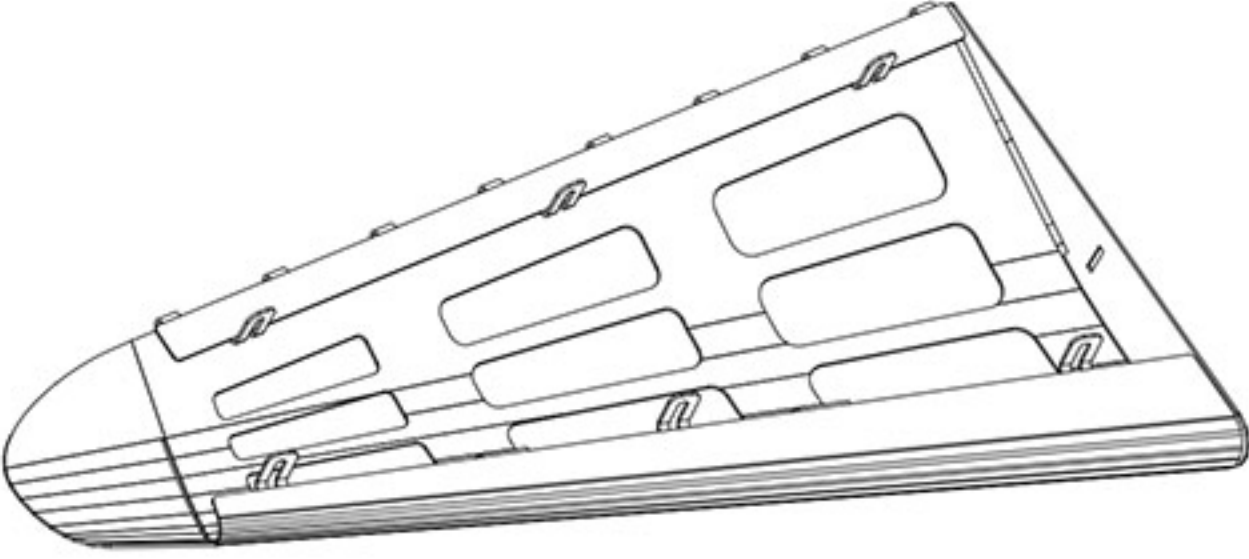



#1



#2

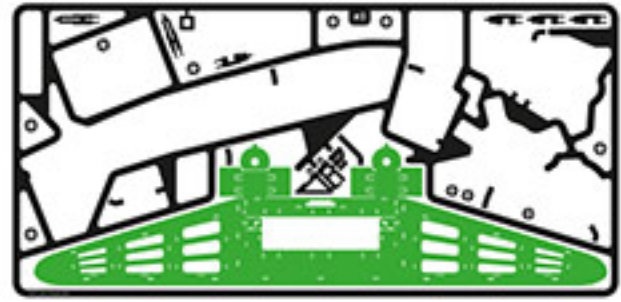

#3

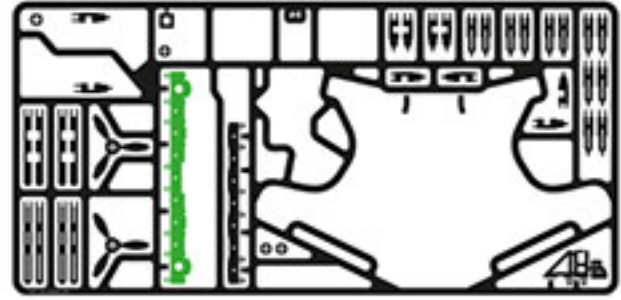

#4

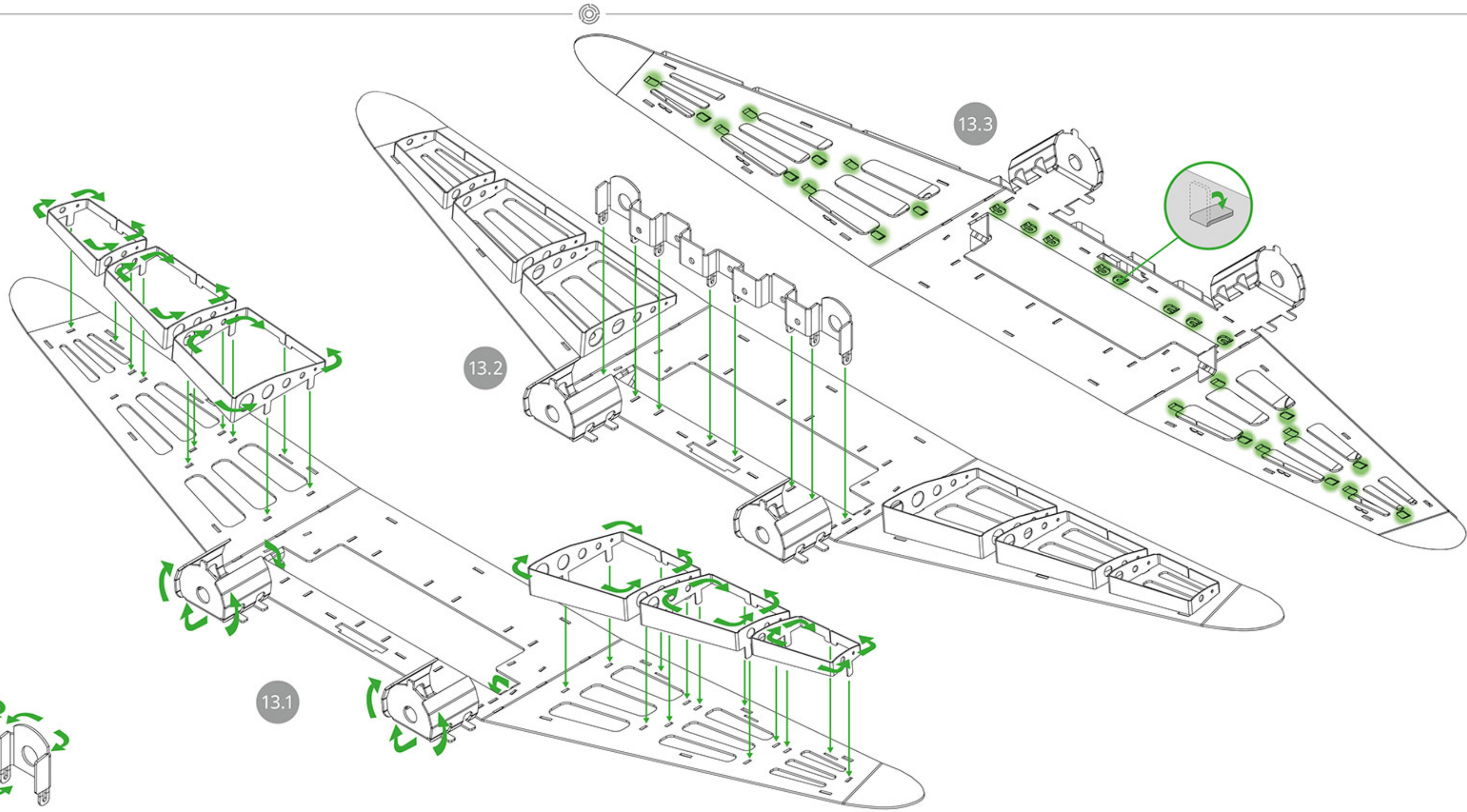

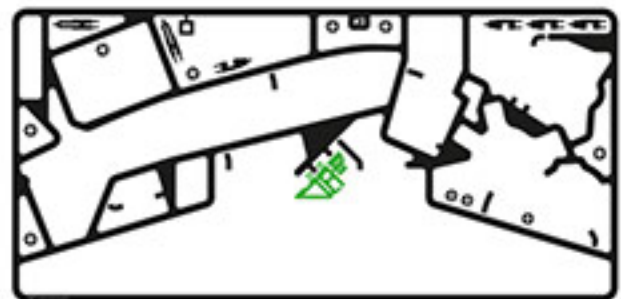

#3

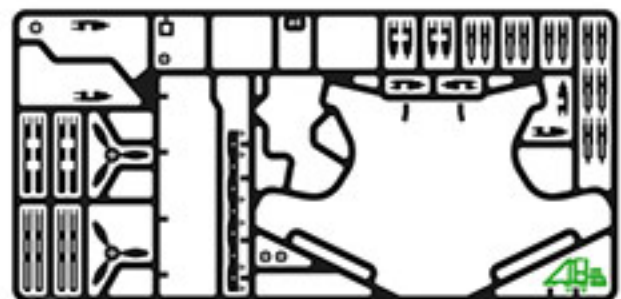

#4

D4 x2

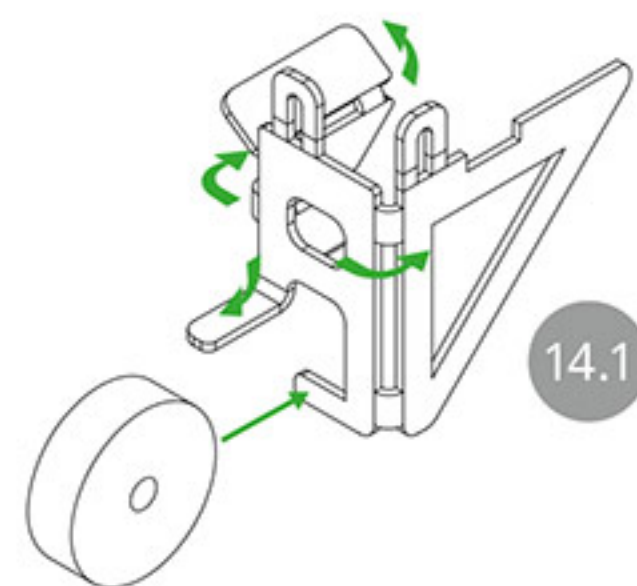

14.1

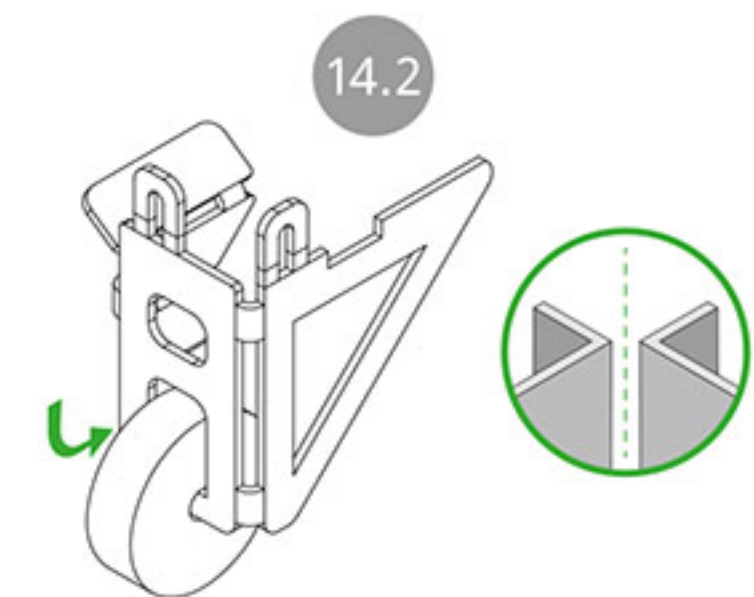

14.2

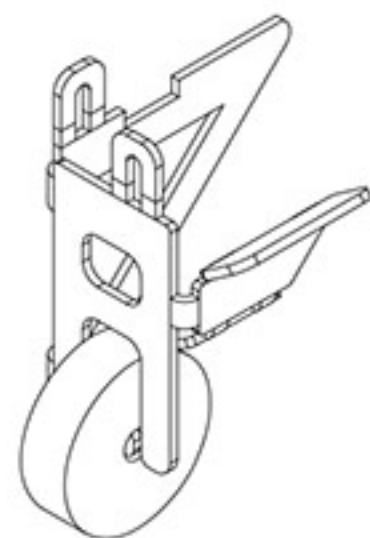

14.3

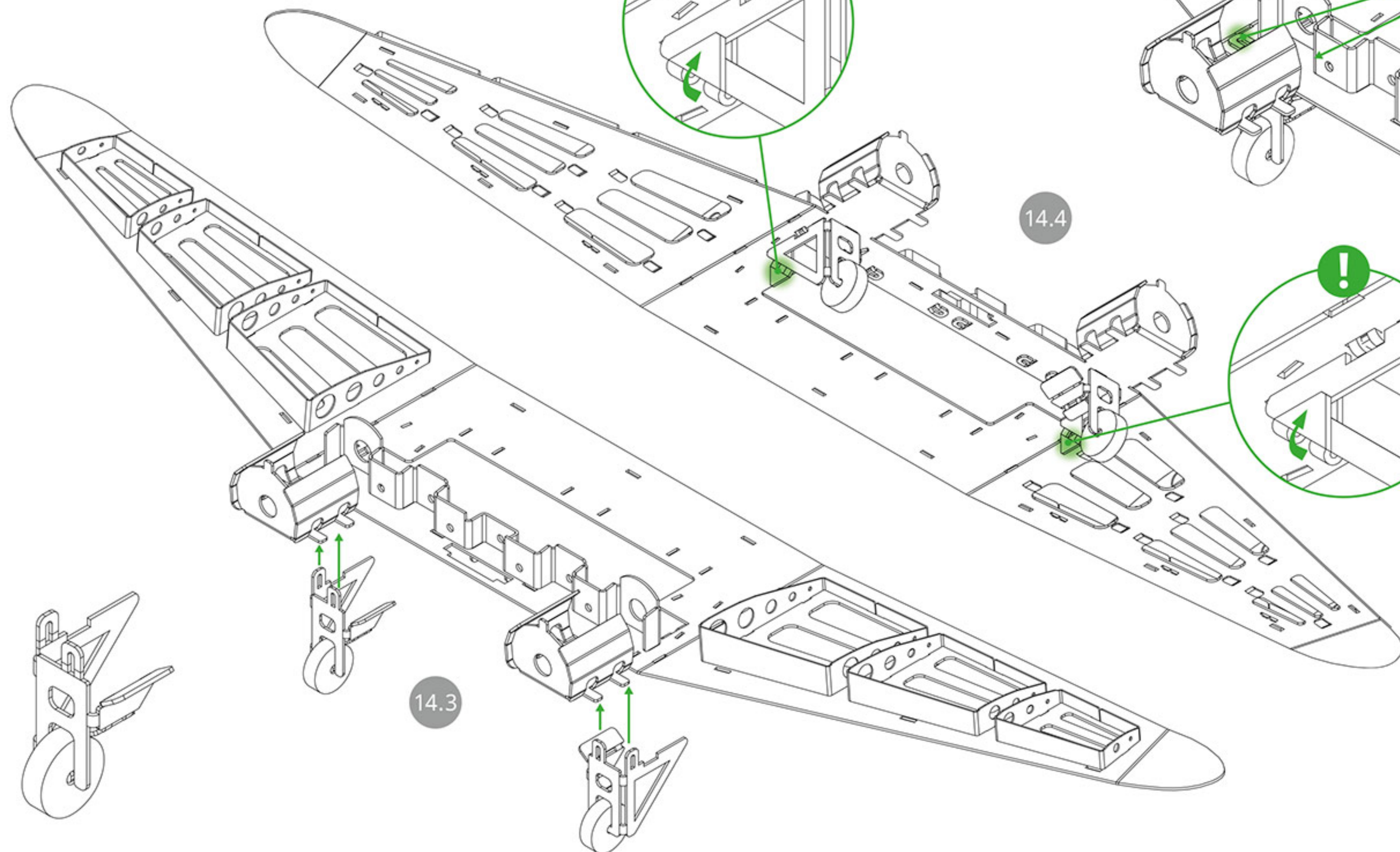

14.4

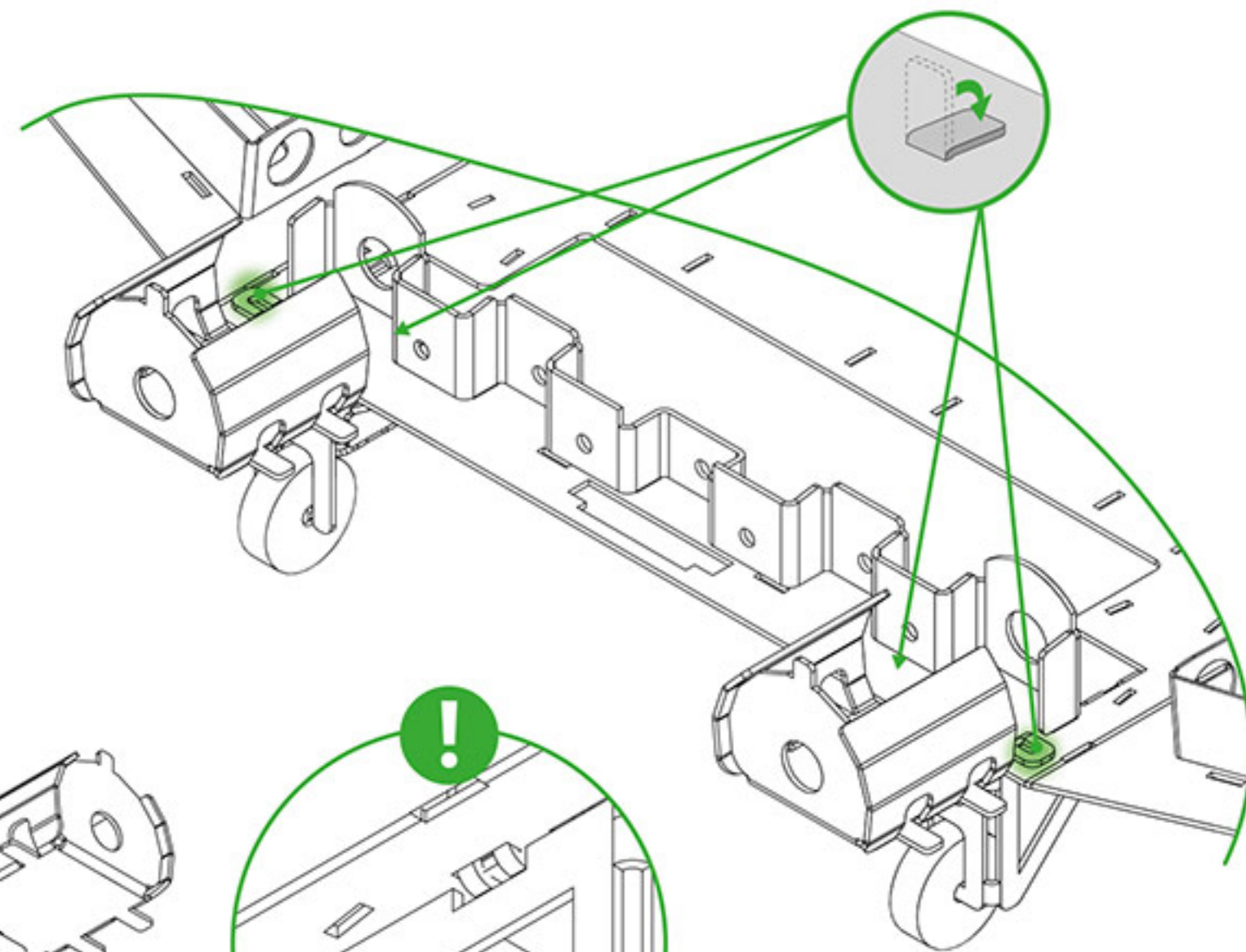

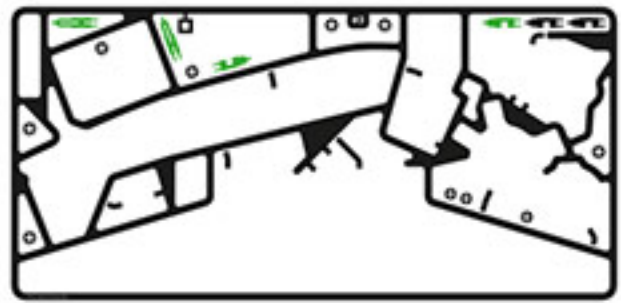

#3

G4 x2

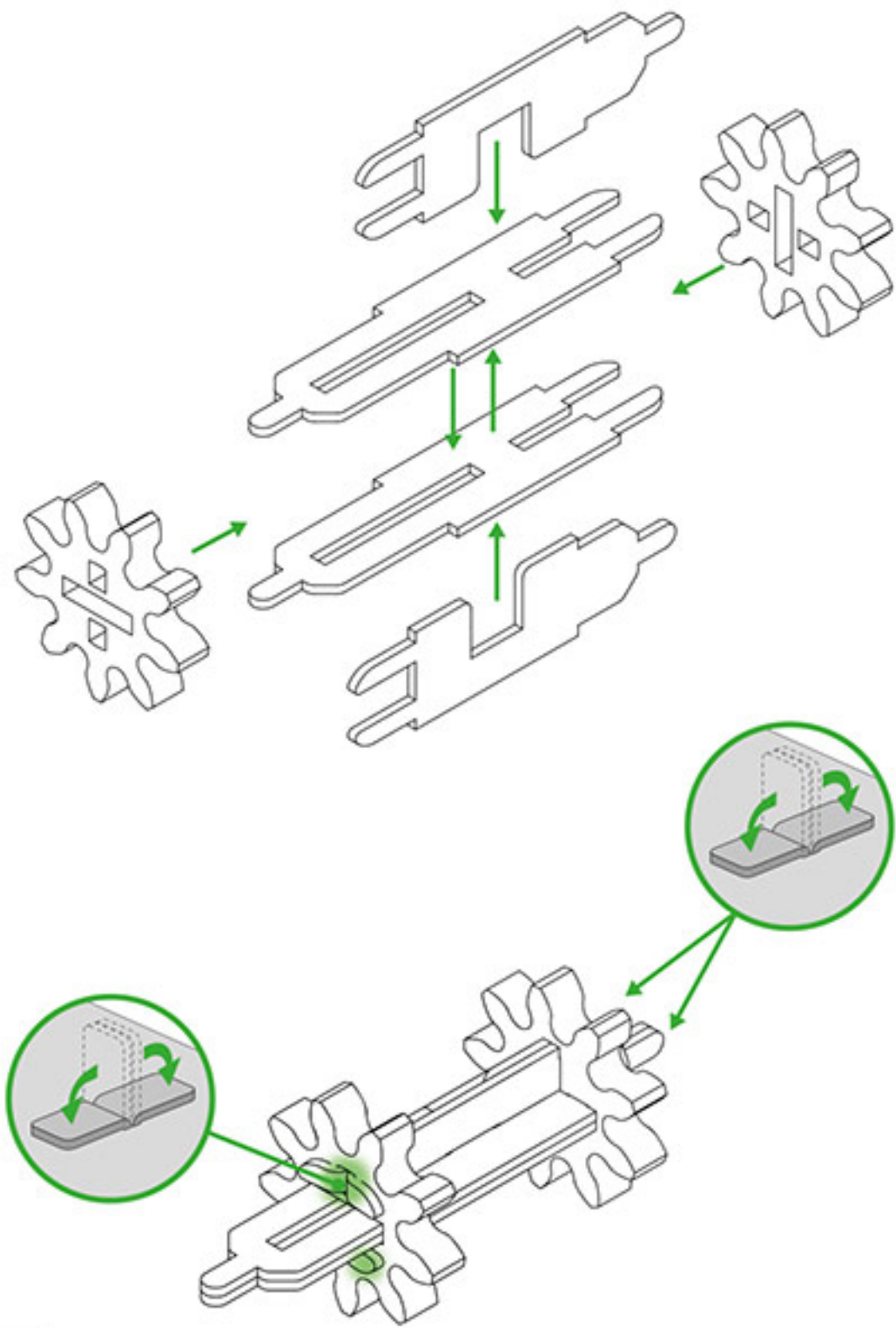

15

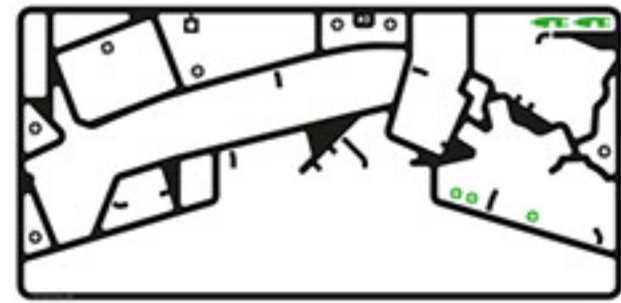

#3

G4 x4

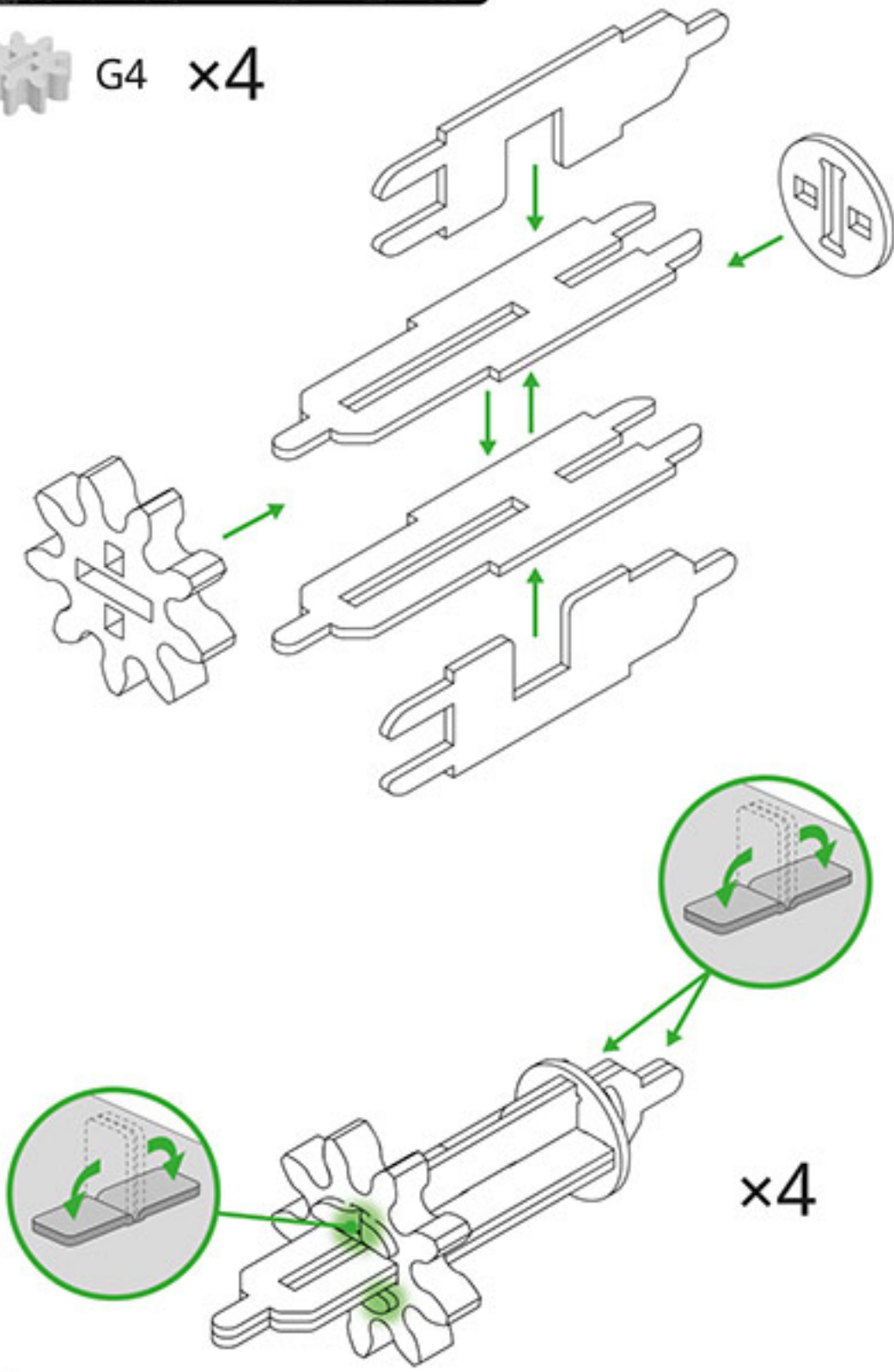

16

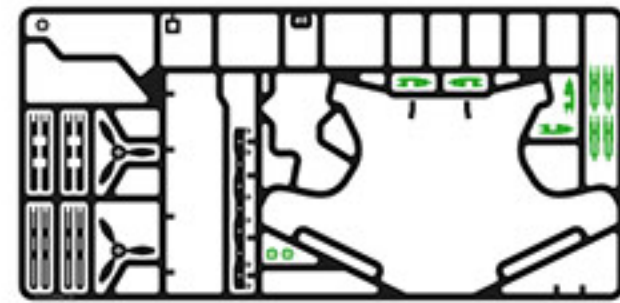

#4

G4 x2

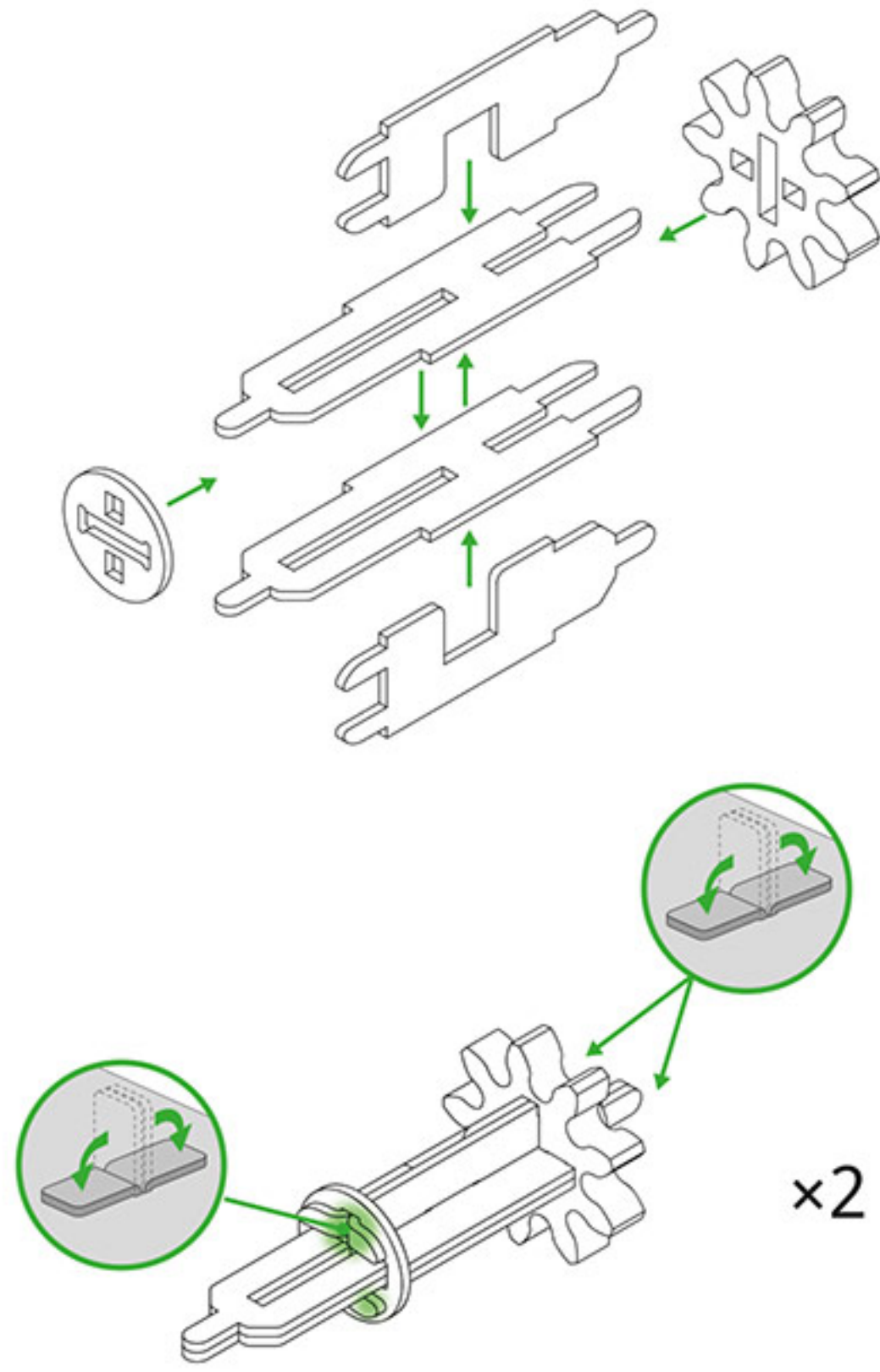

17

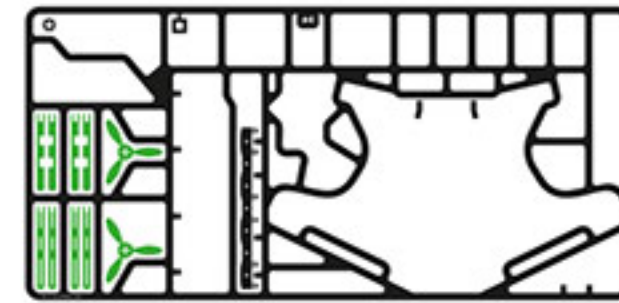

#4

D1 x6

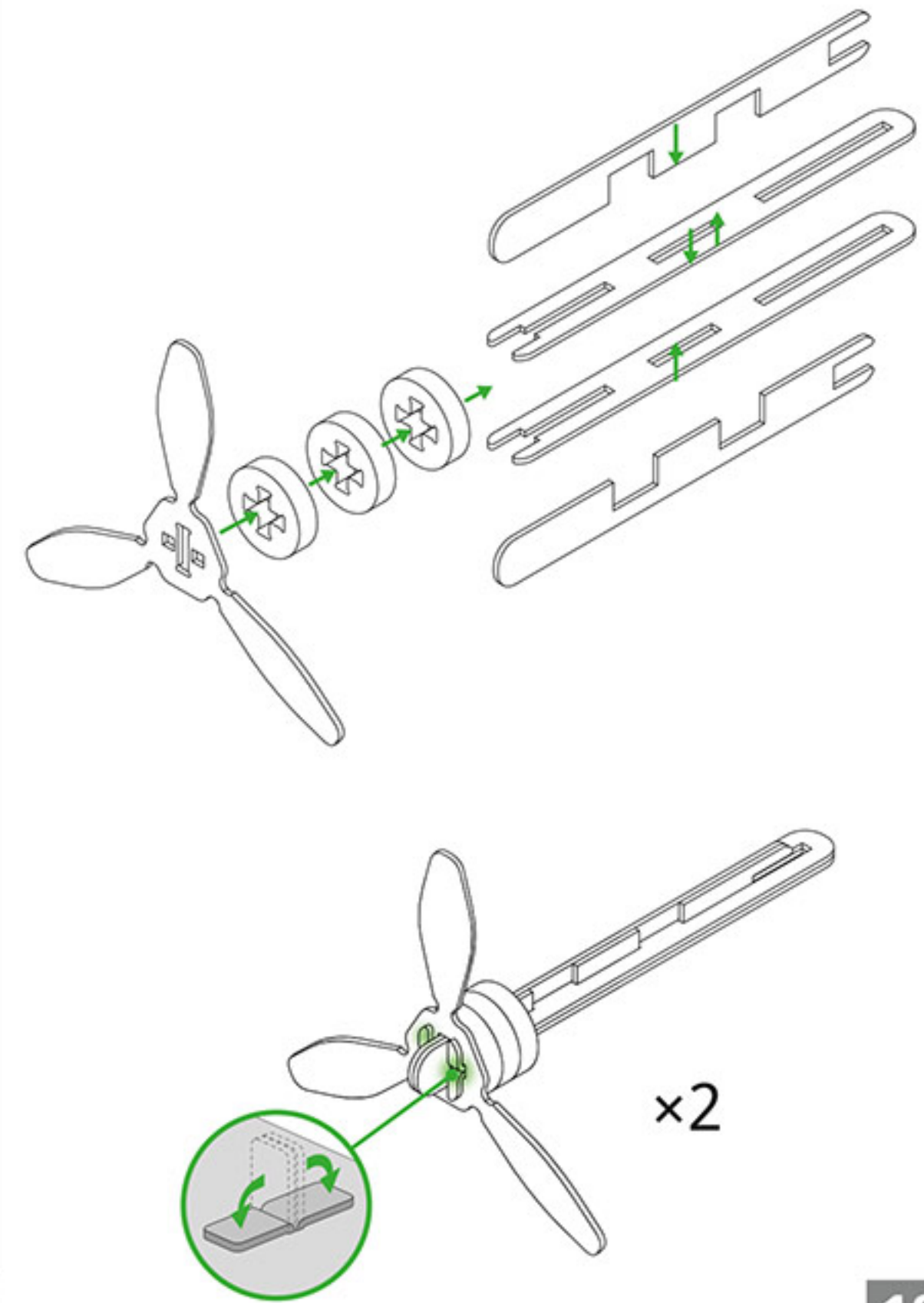

18

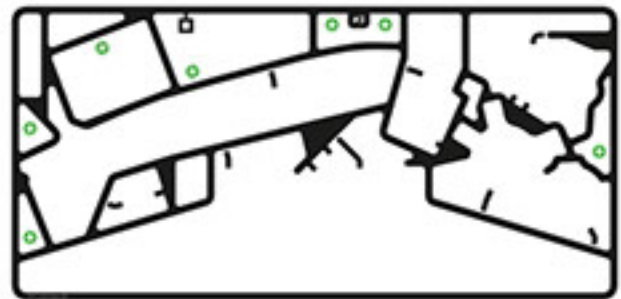

#3

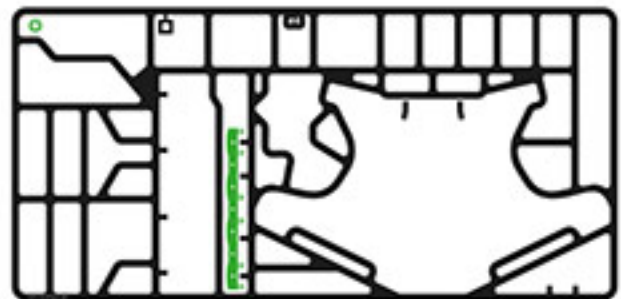
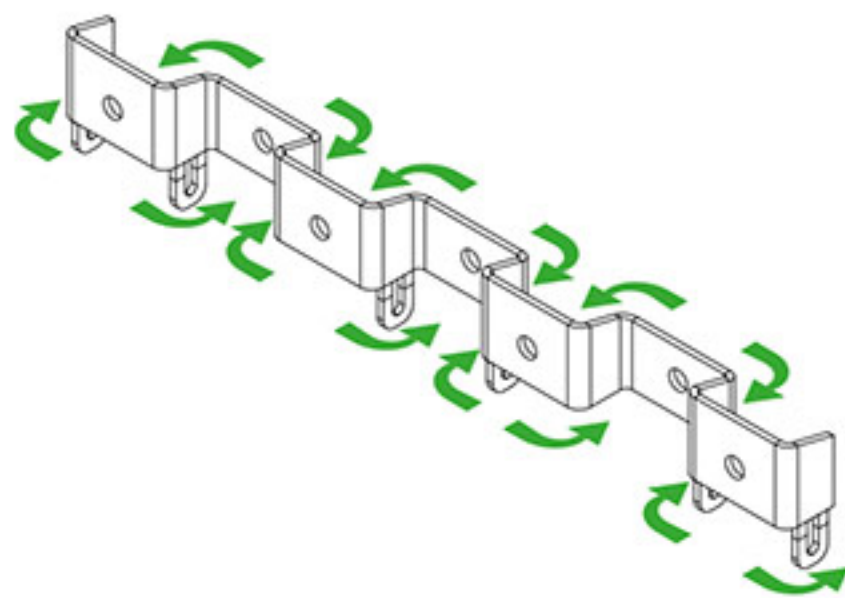

#4

 G4 x2

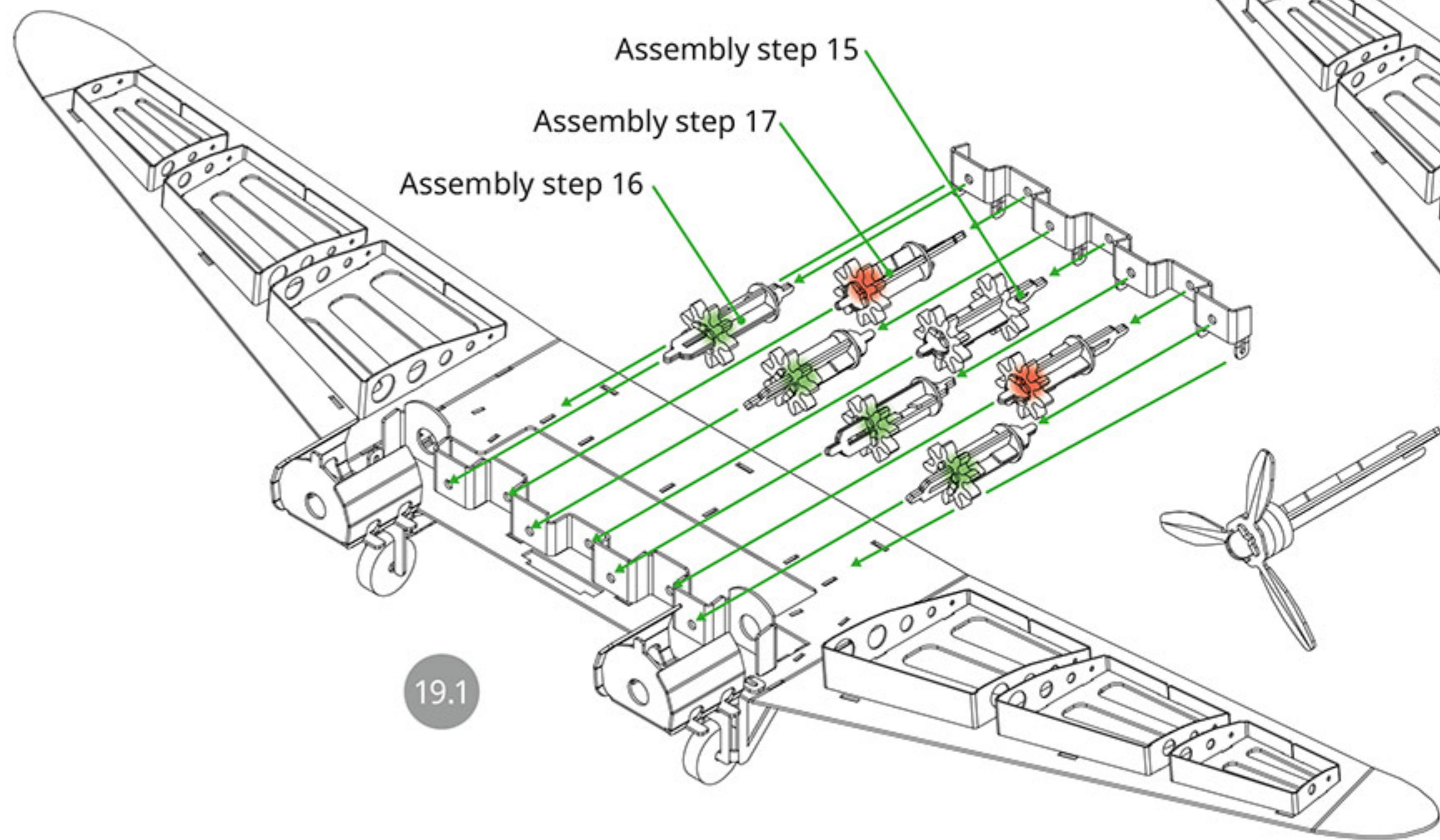

19.1

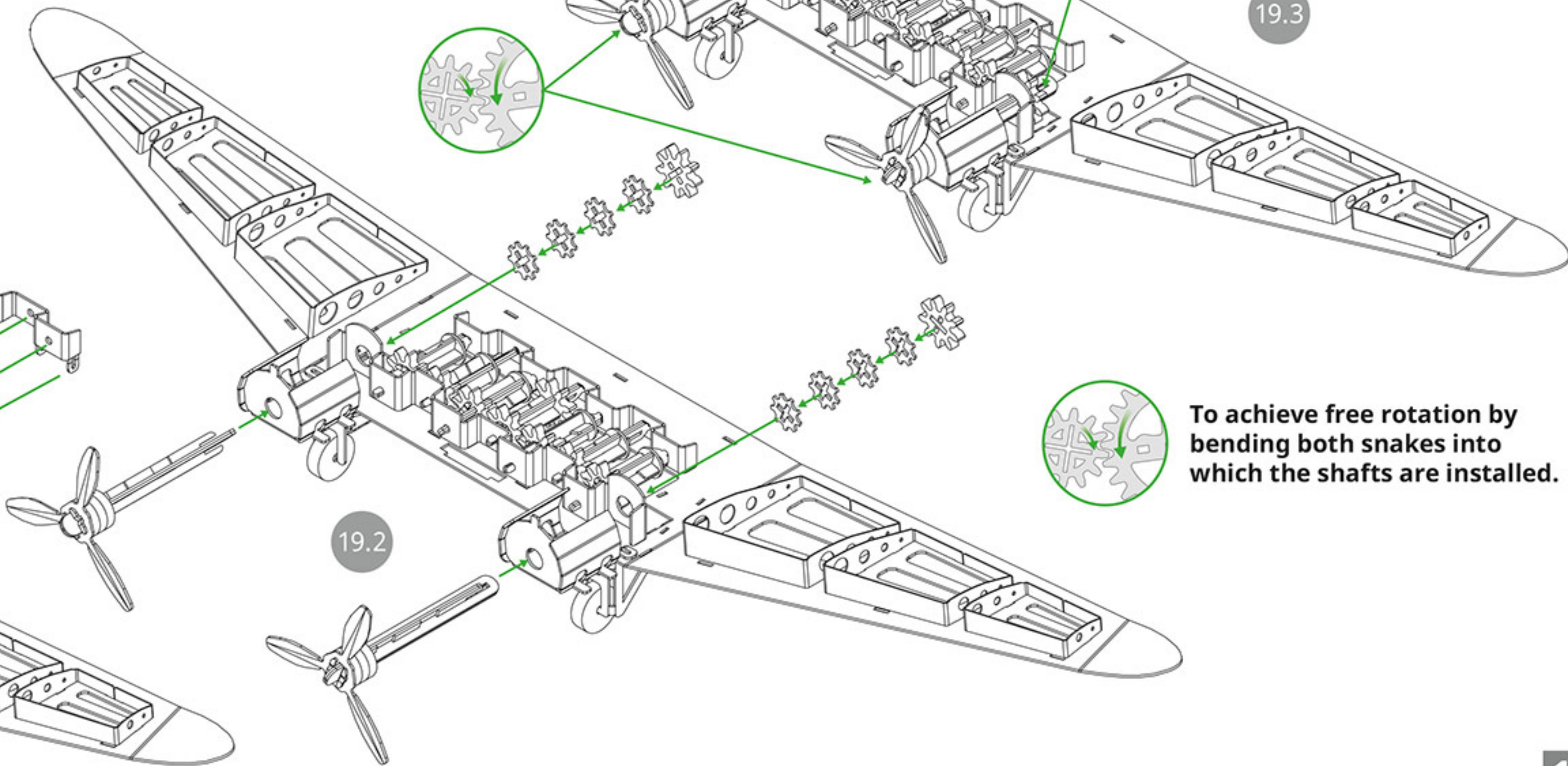

19.2

19.3

 **To achieve free rotation by bending both snakes into which the shafts are installed.**



#1



#2

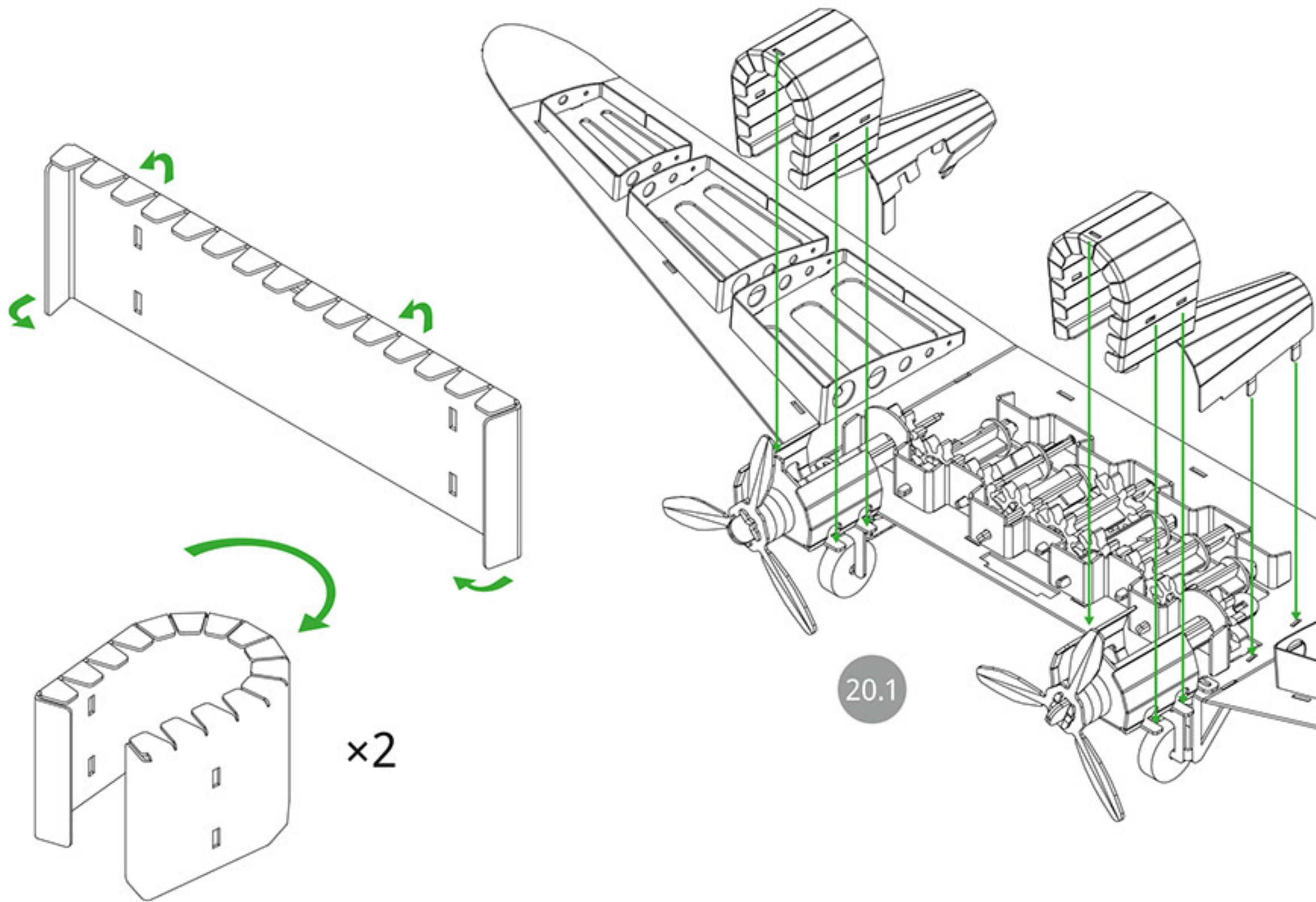

20.1

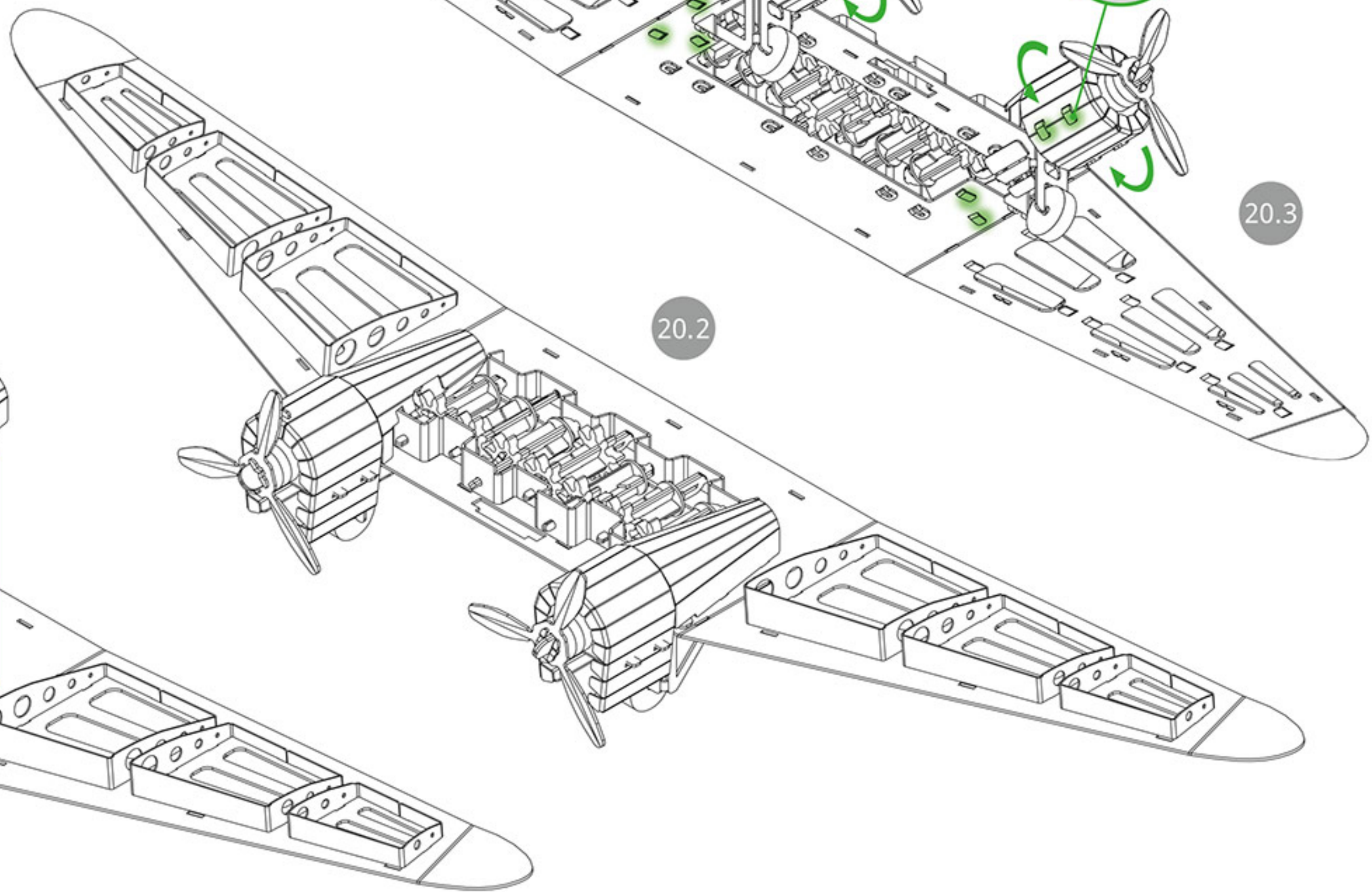

20.2

20.3

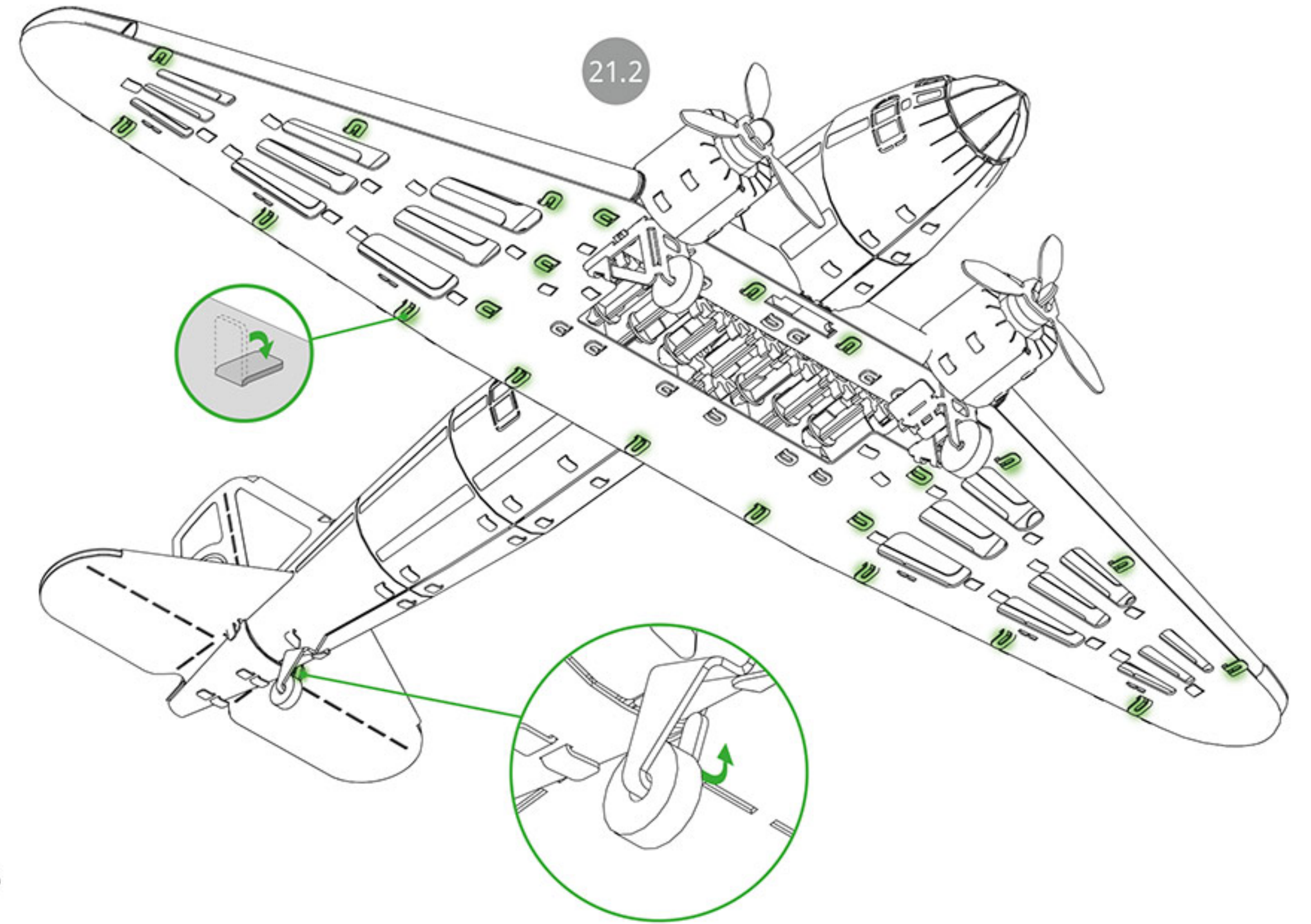
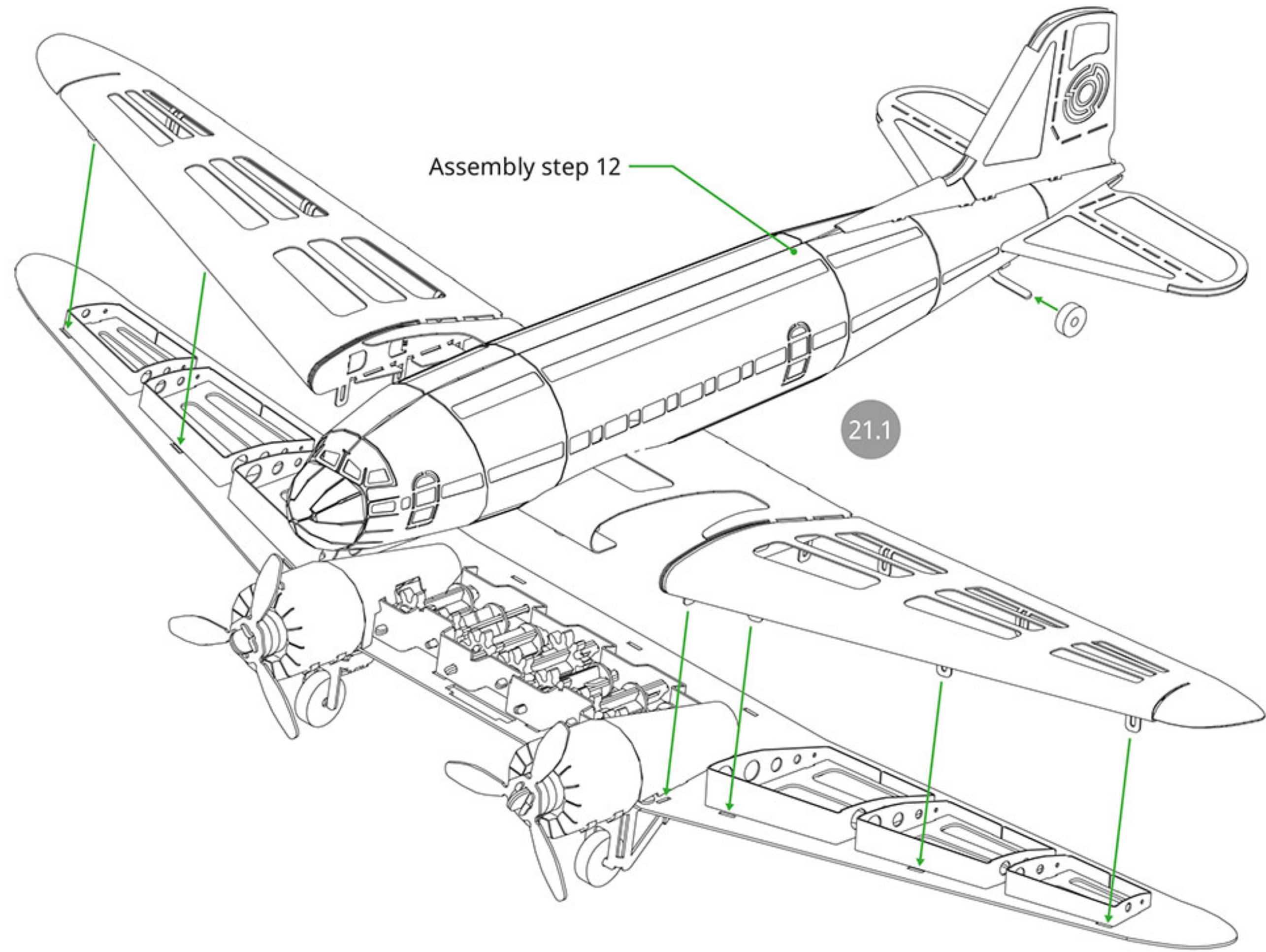

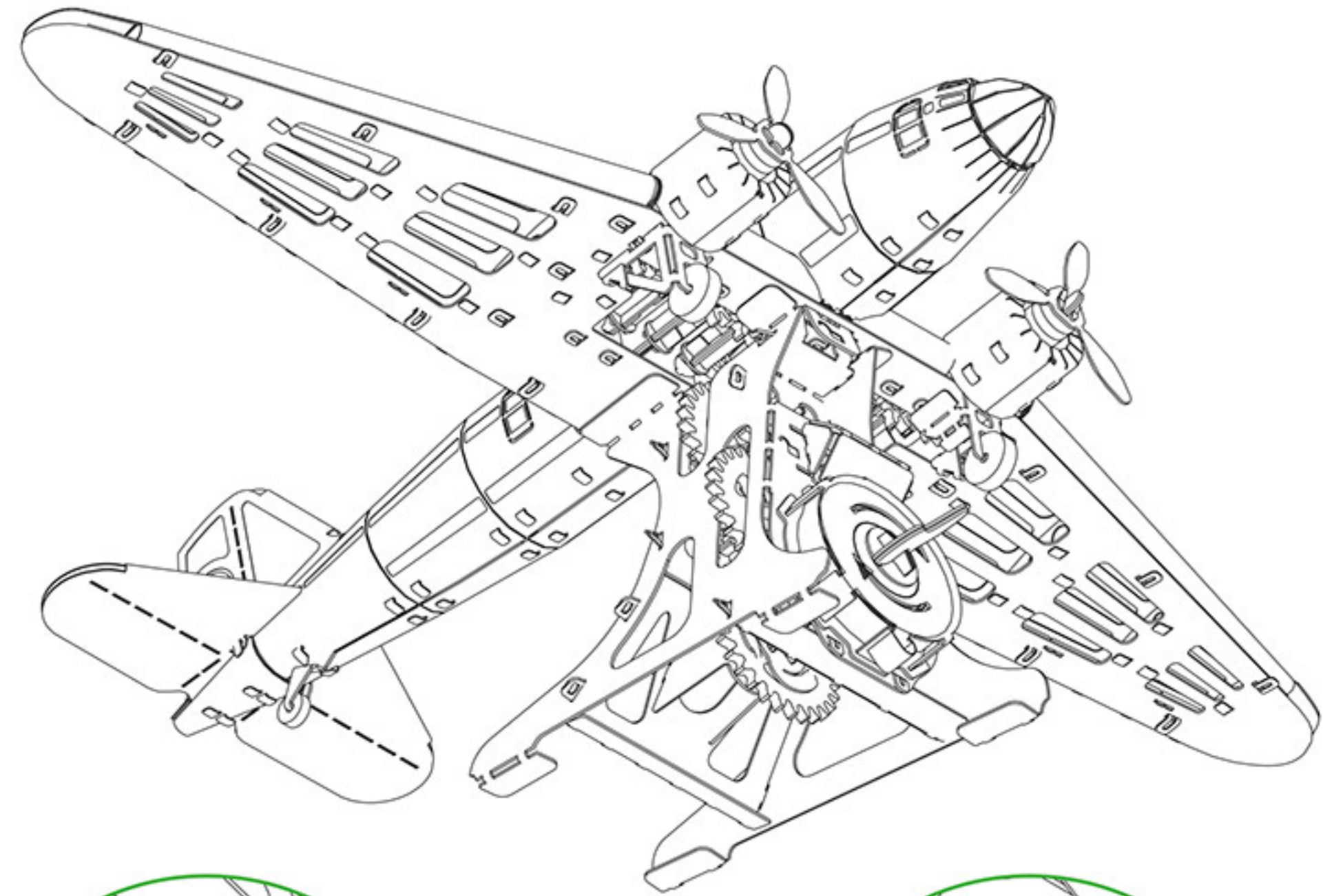
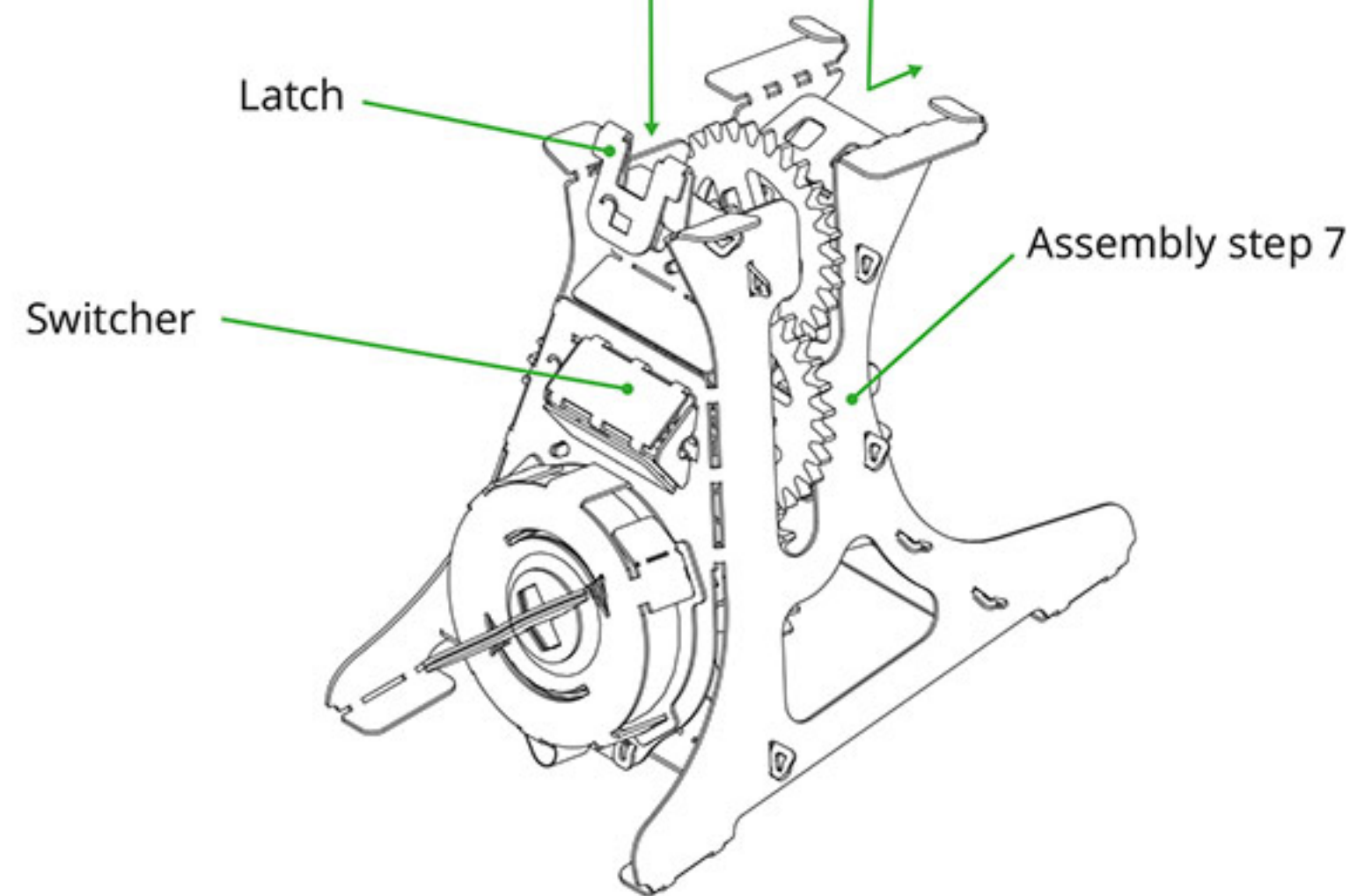
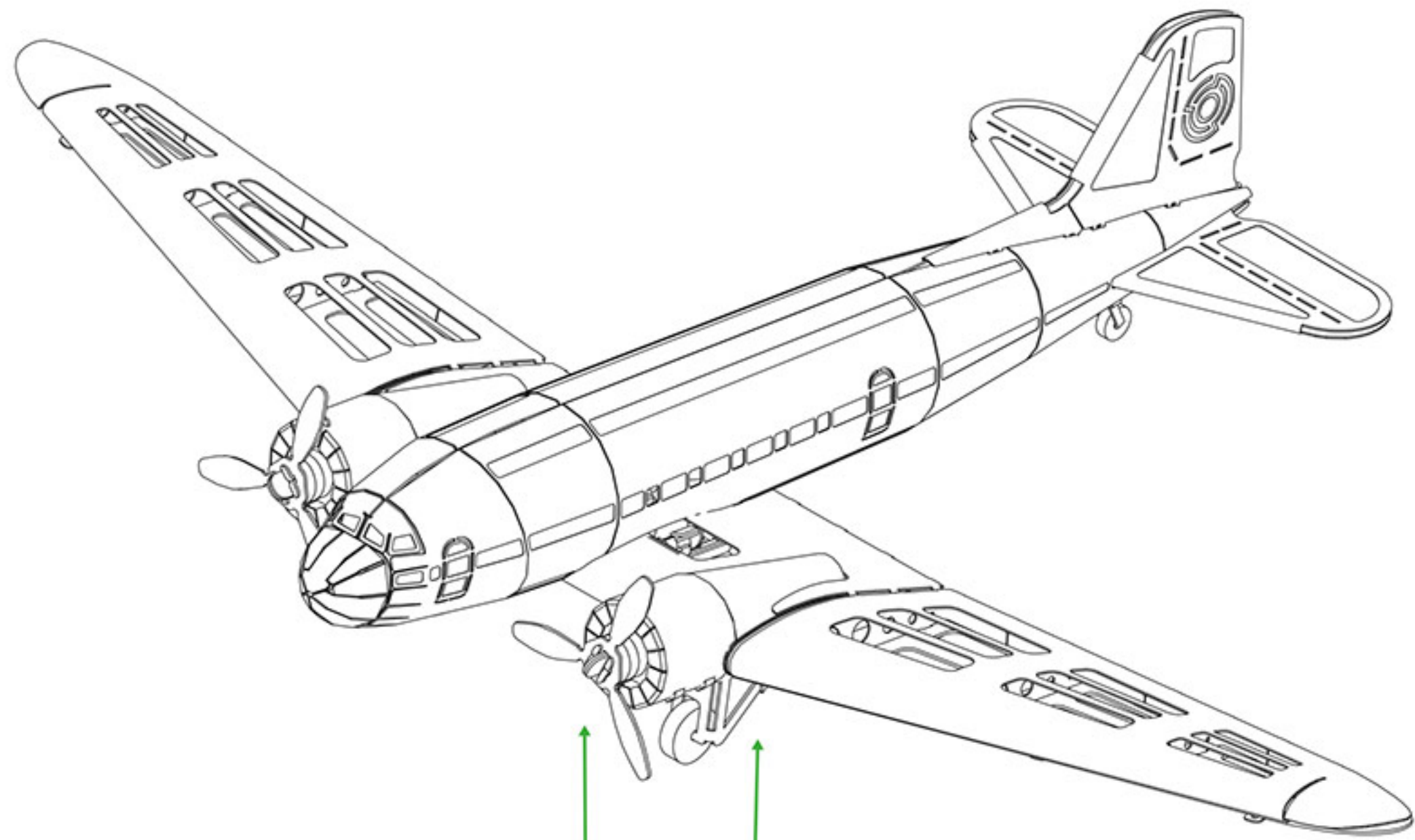

To remove the aircraft from the stand, press the latch.

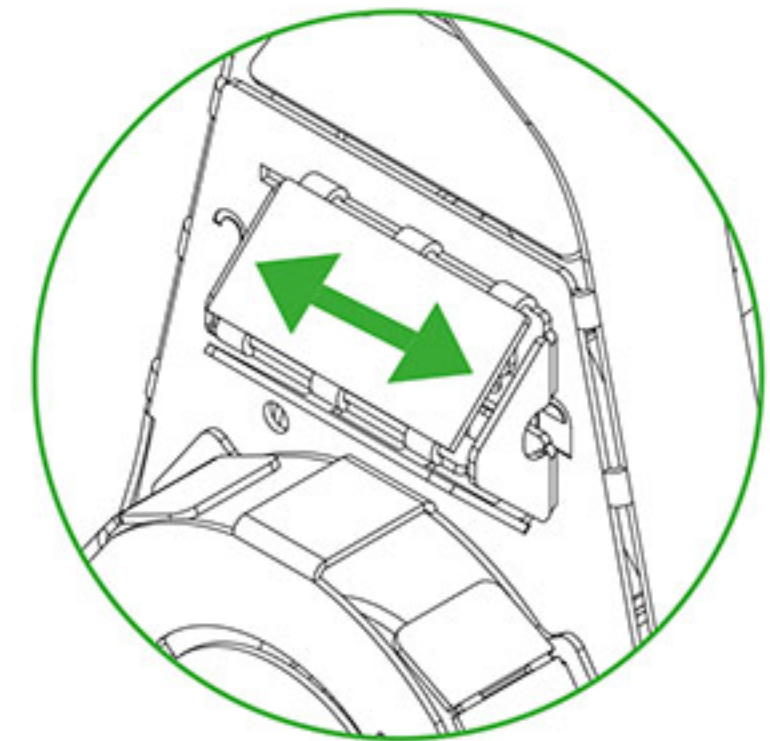

To start the plane, move the switch to the far right, then turn it clockwise. To start, move the switch to the extreme left position



Model name:

REMARKABLE DOUGLAS



Perhaps unique among prewar aircraft, the DC-3 continues to fly in active commercial and military service as of 2022, eighty-seven years after the type's first flight in 1935. There are still small operators with DC-3s in revenue service and as cargo aircraft. Current uses of the DC-3 include passenger service, aerial spraying, freight transport, military transport, missionary flying, skydiver shuttling and sightseeing.

Designed in Ukraine



Made in China

Product number: SKU057

Product material: Stainless steel

Number of metal sheets: 4 pcs

Finish product size: L12.2" × W8.4" × H5" (L31.1cm × W21.2cm × H12.8cm)

⚠ WARNING!

The product contains small and/or sharp parts. Not suitable for children under 3 years of age. Cut/remove the band that keeps the spring in place ONLY WITHIN the spring chamber/container. DO NOT cut the restraining band outside the assembled spring chamber, as the spring will unwind with force.

In order to avoid possible injury from sharp edges, please carefully discard the metal sheet after parts have been removed. This product is not a toy. Keep out of reach of children.

Conforms to CPSIA and CE standards. The product complies with the requirements of EN 71-1,2,3; ASTM F963, REACH, AS/NZS 8124, GB 6675



No expiration date

MODEL
BUILDING
KIT

@hobbadd.cn

霍布德



Collect the Best

Includes: steel sheets, gears, power spring, pliers, file, gloves, polishing cloth, user's guide.

ALL RIGHTS RESERVED
© Metal-Time Inc., USA

www.metal-time.com
info@metal-time.com