

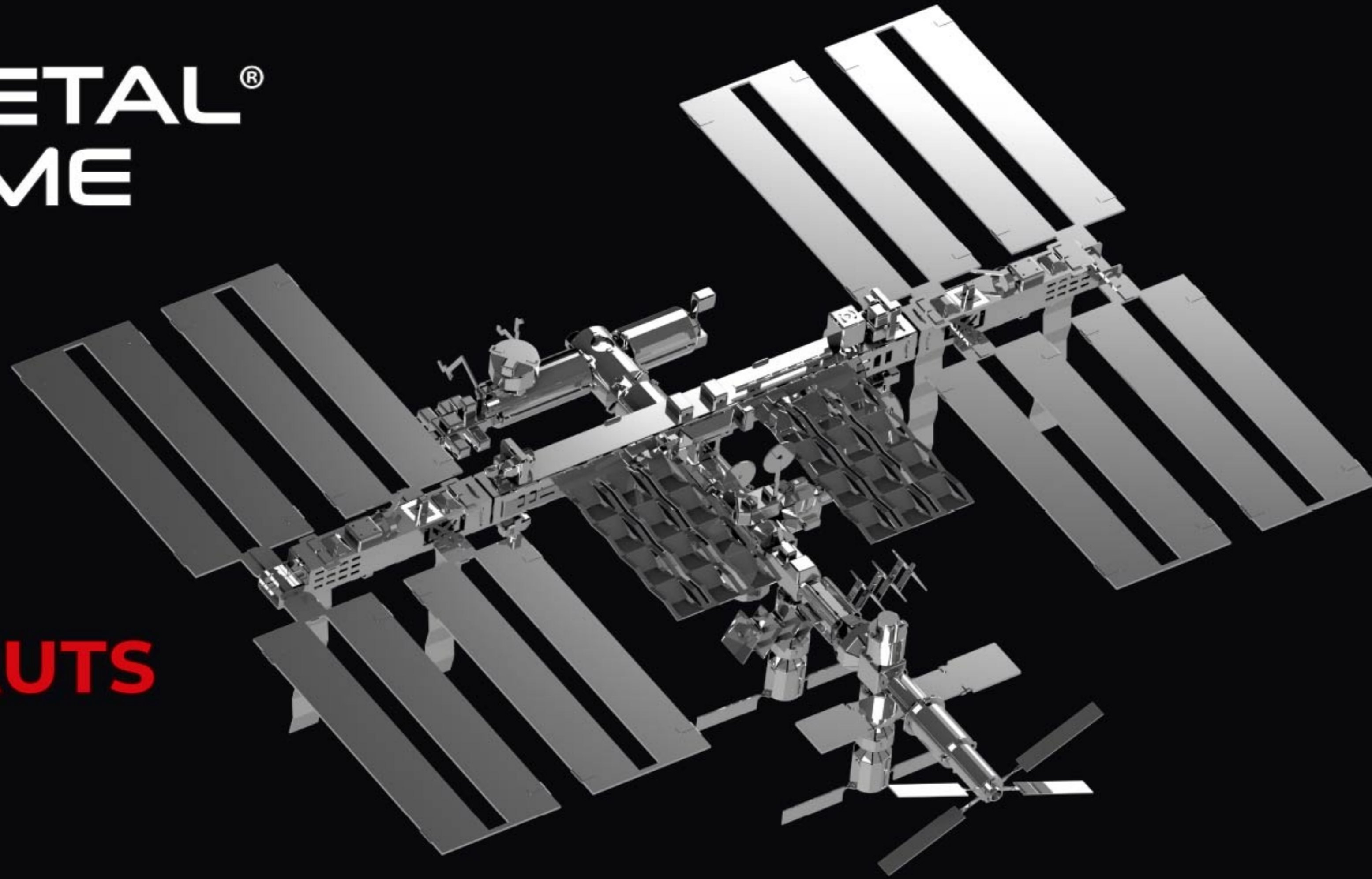

METAL<sup>®</sup>  
TIME



## ASTRONAUTS LODGE

3D Metal Mechanical  
Model Building Kit

Assembly instructions  
Інструкція зі складання  
Instrukcja montażu  
Istruzioni di montaggio  
Montageanleitung  
Instructions de montage  
Instrucciones de montaje  
Instruções de montagem  
Інструкція по сборке  
装配说明书  
조립 설명서  
組立説明書

تعليمات التجميع  
הוראות הרכבה

Collect the Best

229 PIECES

20 hours

Stainless steel / Metal Craft  
Rotating Orbit

AGES  
14+



**WARNING!** PLEASE READ THESE INSTRUCTIONS CAREFULLY BEFORE ASSEMBLY AND USE / **УВАГА!** БУДЬ ЛАСКА, ОЗНАЙОМТЕСЯ З ІНСТРУКЦІЄЮ ПЕРЕД СКЛАДАННЯМ І ВИКОРИСТАННЯМ / **UWAGA!** PROSIMY O UWAŻNE PRZECZYTANIE TEJ INSTRUKCJI PRZED MONTAŻEM I UŻYCIEM / **AVVERTENZE!** SI PREGA DI LEGGERE ATTENTAMENTE QUESTE ISTRUZIONI PRIMA DEL MONTAGGIO E DELL'USO / **ACHTUNG!** BITTE LESEN SIE DIE ANLEITUNG VOR DER MONTAGE UND VERWENDUNG / **ATTENTION!** VEUILLEZ LIRE LE MANUEL AVANT L'ASSEMBLAGE ET L'UTILISATION / **¡ATENCIÓN!** POR FAVOR LEA LAS INSTRUCCIONES ANTES DE MONTAR Y UTILIZAR EL MODELO **ATENÇÃO!** POR FAVOR, LEIA AS INSTRUÇÕES ANTES DA MONTAGEM E DO USO / **ВНИМАНИЕ!** ПОЖАЛУЙСТА, ОЗНАКОМЬТЕСЬ С ИНСТРУКЦИЕЙ ПЕРЕД СБОРКОЙ И ИСПОЛЬЗОВАНИЕМ / **注意!** 装配和使用产品前请阅读使用说明书 / **경고!** 조립 및 사용 전에 설명서를 잘 읽고 숙지해 주십시오 / **ご注意!** 組立て使用する前に説明書をお読んでください / يرجى قراءة التعليمات قبل التجميع والاستخدام / **تحذیر!** / **אזהרה!** אנא קרא הוראות אלה בהירות לפני ההרכבה השימוש **אזהרה!**

**EN** When assembling the model, don't rush, avoid pointing details at yours or anyone else's face. If one of the parts has a sharp edge, please file it down. Use pliers and additional tools to assemble the model. Each kit contains a cloth for wiping and polishing the model once it's assembled.

**UA** Під час складання не поспішайте, не спрямовуйте деталі в обличчя собі або іншим. Якщо деталь має гострий край, обробіть його надфілем. Для складання використовуйте плоскогубці та додатковий інструмент. У комплект входить ганчірка, якою можна протерти модель після складання.

**PL** Podczas montażu trzeba unikać pośpiechu i skierowania elementów drobnych w twarz sobie lub innym. Jeśli element zawiera

ostrą krawędź, wyszlifuj powierzchnię pilnikiem. Użyj szczypiec i dodatkowych narzędzi do montażu. Każdy zestaw zawiera ściereczkę do wycierania i polerowania modelu po jego złożeniu.

**IT** Assemblare senza fretta, non puntare le parti verso il proprio volto o verso i volti degli altri. Si una delle parti ha un bordo tagliente, smussarlo con una lima. Usare le pinze ed attrezzi aggiuntivi. Il kit contiene un panno lucidante per pulire il modello dopo il montaggio.

**DE** Achten Sie bei der Montage des Modells darauf, dass Sie damit nicht auf Ihr Gesicht oder das einer anderen Personen zielen. Wenn das Teil eine scharfe Kante enthält, feilen Sie es ab. Verwenden Sie zur Montage eine Flachzange und ein zusätzliches Werkzeug. Jeder

Bausatz enthält ein Poliertuch zum Abwischen und Polieren des Modells nach der Montage.

**FR** Pendant l'assemblage, ne vous précipitez pas, ne dirigez pas les pièces vers votre visage ou sur les autres. Si une pièce contient un bord coupant, limez-le. Pour l'assemblage, utilisez une pince et un outil supplémentaire. Le kit comprend un chiffon pour pouvoir polir le modèle après l'assemblage.

**ES** Cuando montado el modelo, no se apresure y evite apuntar a su cara o la cara de otra persona. Si una pieza del modelo tiene un borde afilado, limelo, por favor. Use alicates u otros instrumentos para montar el modelo. Cada kit contiene un tela para limpiar y pulir el modelo una vez cuando esté ensamblado.

**PT** Durante a montagem, não se precipite, não aponte as peças na sua cara ou na de outras pessoas. Se a peça tiver uma borda afiada, lixe-a. Use um alicate e uma ferramenta adicional para montar. O kit inclui um pano que pode ser usado para limpar o modelo após a montagem.

**RU** Во время сборки не спешите, не направляйте детали в лицо себе или другим. Если деталь имеет острый край, обработайте его напильником. Для сборки используйте плоскогубцы и дополнительный инструмент. В комплект входит тряпочка, которой можно протереть модель после сборки.

**CN** 当组装模型时, 不要别忙, 不要把零件放向你的脸或别人的脸上。如果一个模型部件有锋利的边缘,

用锉把它加工一下。使用钳子和附加的配件来装配模型。套件包括一块布, 组装后您可以用它擦拭模型。如有需要, 可将硅基润滑脂应用于弹簧及机构;

**KR** 모델을 조립할 때 서두르지 말고 부품을 본인 얼굴이나 다른 사람의 얼굴을 향하여 조립하지 마십시오. 부품 중 하나에 날카로운 부분이 있으면 다듬어 주십시오. 펜치 및 추가 도구를 사용하여 모델을 조립하십시오. 각 키트에는 조립된 모델을 닦이 위한 천이 들어 있습니다. 필요한 경우, 적은 양의 실리콘 기반 그리스를 스프링과 메커니즘에 바를 수 있습니다.

**JP** モデルの組み立て中に、急いで組立てたり、使用者の顔または他人の顔へ向けたりしないでください。先が鋭い部品がございましたら、必ず下へ向けてください。キットと共に付属されているペンチと追加ツールを使用してモデルを正しく組み立

てください。組立後のモデルをの拭き取り及び研磨用の布が各キットに同梱されています。必要に応じて、少量のシリコンベース潤滑剤をバネやメカニズムに

**AR** عند تجميع النموذج لا تستعجل وتتجنب إشارة الأجزاء الى وجهك او وجه شخص آخر. اذا كان أحد الأجزاء له حافة حادة فالرجاء إزالتها بالمبرد. استخدم زردية و أدوات إضافية لتجميع النموذج. يحتوي الطقم على قطعة من القماش للمسح والتلميع بعد تجميع النموذج. اذا لزم الأمر يمكنك وضع الشحوم السيليكونية على

**HE** כשמרכיבים את הדגם, אל תמהר, הו, הימנעו מהפניית פרטים לעבר הפנים שלכם או של מישהו אחר. אם לאחד החלקים קצה חד, אנא הגש אותו למטה. השתמשו בציבת ובכלים נוספים להרכבת הדגם. כל ערכה מכילה מטלית לניגוב והברקה של הדגם לאחר הרכבתו. במידת הצורך, תוכלו לבחור למרוח כמות קטנה של שומן על בסיס סילי

**EN WARNING!** Product contains small parts and sharp parts. Not suitable for children under 3 years of age

**UA УВАГА!** Продукт містить дрібні та гострі деталі. Не призначено для дітей до 3-х років

**PL UWAGA!** Produkt zawiera małe i ostre elementy. Nieodpowiednie dla dzieci w wieku poniżej 3 lat

**IT AVVERTENZE!** Il prodotto contiene parti piccole e/o taglienti. Non destinato ad essere utilizzato dai bambini di età inferiore a 3 anni

**DE ACHTUNG!** Das Produkt enthält kleine und scharfe Teile. Nicht geeignet für Kinder unter 3 Jahren

**FR ATTENTION!** Le produit contient de petites pièces qui peuvent être tranchantes. Ne pas laisser à portée d'enfants de moins de 3 ans

**ES ¡ATENCIÓN!** El producto contiene piezas pequeñas y partes afiladas. No apto para niños menores de 3 años

**PT ATENÇÃO!** O produto contém peças pequenas e pontiagudas. Não se destina a crianças menores de 3 anos

**RU ВНИМАНИЕ!** Продукт содержит мелкие и острые детали. Не предназначено для детей до 3-х лет

**CN 注意!** 产品包括小零件和尖锐零件。不适合3岁以下儿童

**KR 경고!** 제품에 작은 부품과 날카로운 부품이 들어 있습니다. 3세 미만의 어린이에게는 적합하지 않습니다

**JP 警告!** 製品には小さくて鋭い部品があります。3歳未満のお子様には絶対に与えないでください。

**AR تحذیر!** يحتوي المنتج على أجزاء صغيرة وأجزاء حادة. غير مناسب للأطفال تحت سن 3

**HE אזהרה!** המוצר מכיל חלקים קטנים וחלקים חדים לא מתאים לילדים מתחת לגיל 3

**MODEL PARTS AND ASSEMBLY TOOLS / КОМПЛЕКТАЦІЯ ДЕТАЛЕЙ ТА ІНСТРУМЕНТІВ  
ELEMENTY I NARZĘDZIA MONTAŻOWE / LE PARTI DEL MODELLO E ATTREZZI DI MONTAGGIO  
MODELLTEILE UND MONTAGEWERKZEUGE / COMPOSITION DU KIT / PIEZAS DEL MODELO Y HERRAMIENTAS DE ENSEMBLAR  
PEÇAS DE MONTAGEM DO KIT / КОМПЛЕКТАЦІЯ ДЕТАЛЕЙ СБОРКИ / 零件包括清單 / 모델 부품과 조립 도구 / モデル部品と組立ツール  
חלקי דגם וכלים להרכבה / أجزاء النموذج وأدوات التجميع**

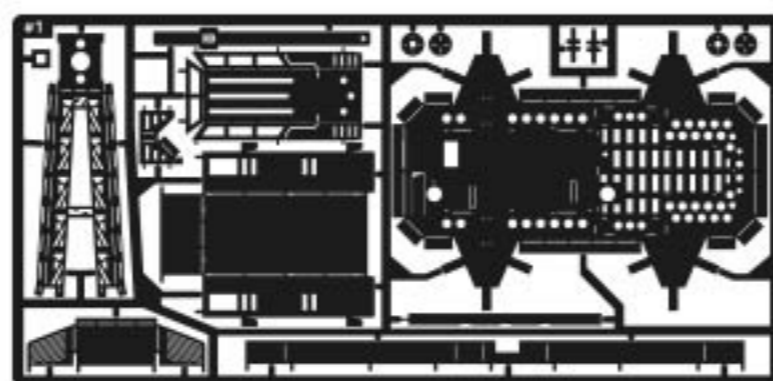

#1

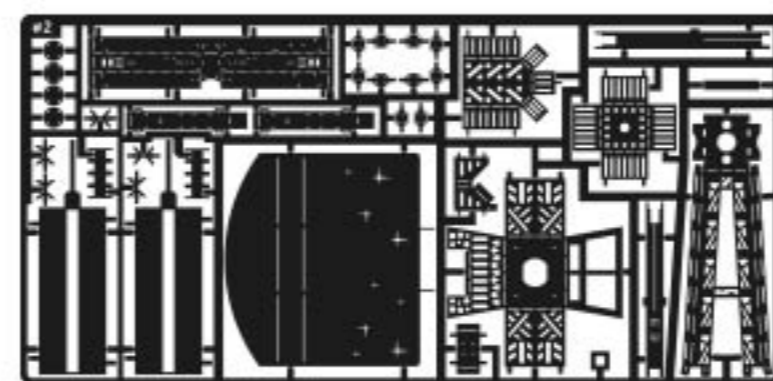

#2

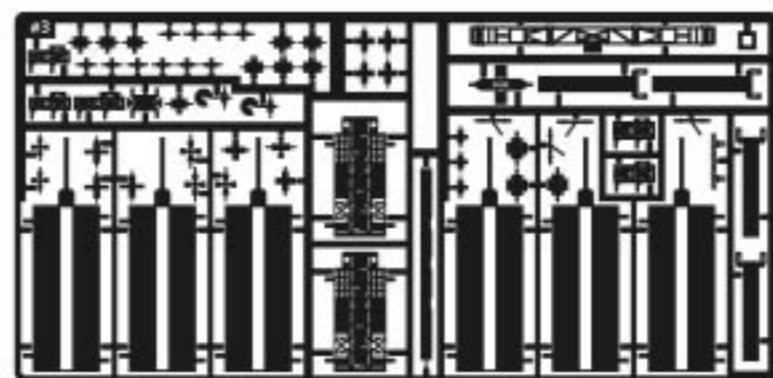

#3

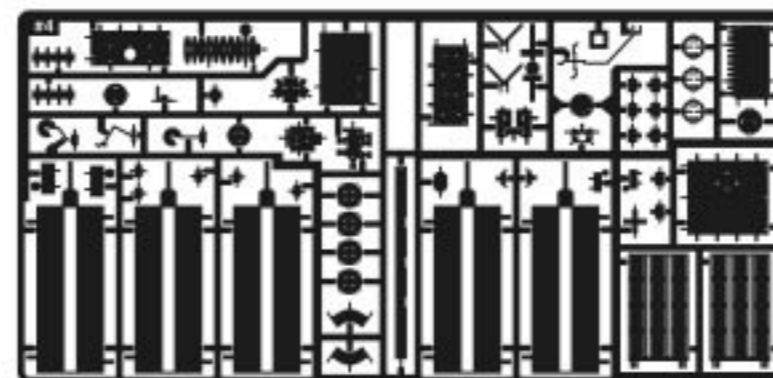

#4

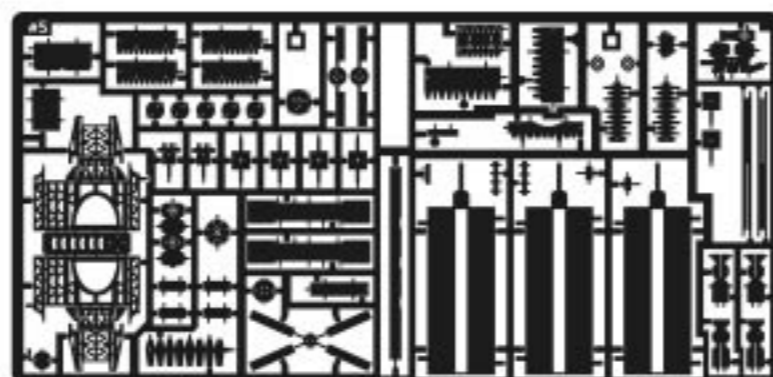

#5

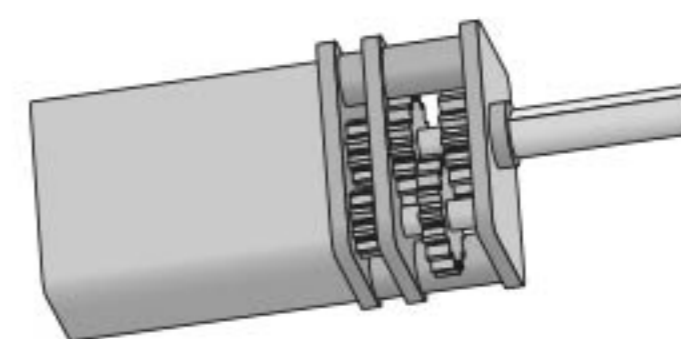

Engine / Двигун / Silnik / Motore  
Motor / Moteur / Motor / Motor  
Двигатель / 引擎 / 엔진 / エンジン  
محرك / מנוע

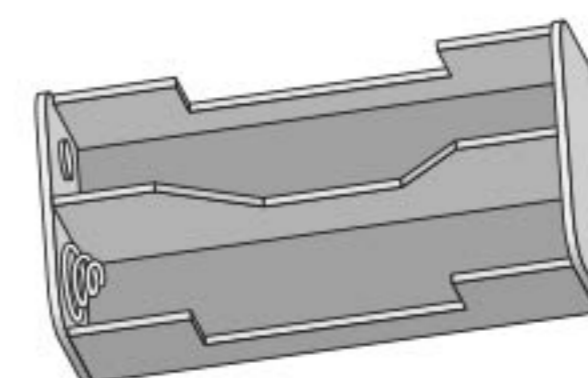
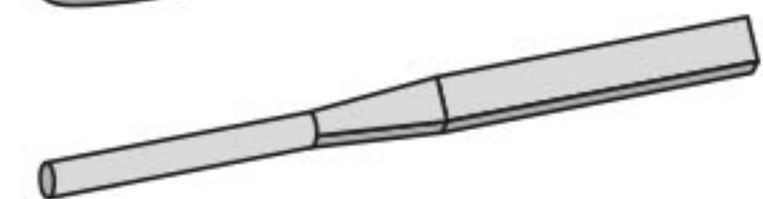
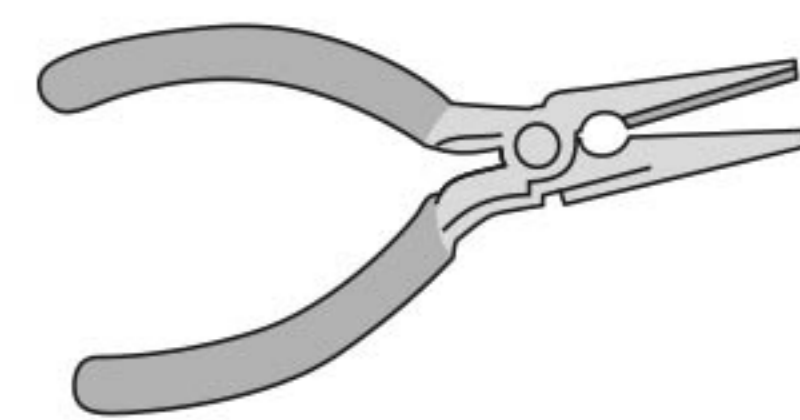

Battery holder / Тримач батарейок  
Uchwył baterii / Portabatterie  
Batteriehalter / Support de batterie  
Soporte de la batería / Suporte da bateria / Держатель батареек  
電池座 / 배터리 홀더 / 배터리-홀더  
בעל סוללה / حامل البطارية

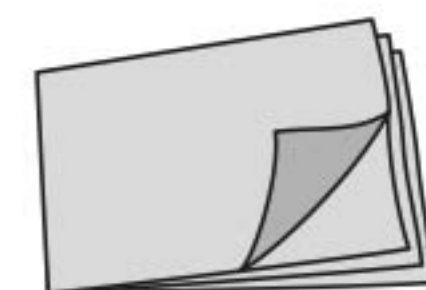

Tools / Інструменти / Instrumenty  
Attrezzi di montaggio / Werkzeuge  
Outils / Herramientas / Instrumentos  
Ferramentas / Инструменты  
工具 / 도구 / ツール  
כלים / أدوات

**EN** Model for collectors, suitable for children 14+ **UA** Модель для колекціонерів, підходить для дітей від 14 років **PL** Model dla kolekcjonerów, odpowiednie dla dzieci w wieku 14 lat **IT** Modello per collezionisti, destinato ad essere utilizzato dai bambini dai 14 anni **DE** Modell für Sammler, geeignet für Kinder ab 14 Jahren **FR** Modèle pour collectionneurs, à partir de 14 ans **ES** El modelo para coleccionistas, apto para niños mayores de 14 años **PT** Modelo de colecionador, adequado para crianças maiores de 14 anos **RU** Модель для коллекционеров, подходит для детей старше 14 лет **CN** 收藏家模型, 适合14岁以上儿童 **KR** 수집가용 모델입니다, 14세 이상 어린이에게 적합합니다 **JP** コレクターのためのモデルです。14歳以上の子供達のためにです **AR** نموذج لهواة التجميع ، مناسب للأطفال من عمر 14 عامًا **HE** זקרה! המוצר מכיל חלקים קטנים וחלקים חדים לא מתאים לילדים מתחת לגיל 3

STANDARD FIXING OF FASTENERS / СТАНДАРТНА ФІКСАЦІЯ КРІПІЛЬНИХ ЕЛЕМЕНТІВ / STANDARDOWE MOCOWANIE ŁĄCZNIKÓW  
 FISSAGGIO STANDARD DI ELEMENTI DI FISSAGGIO / STANDARDBEFESTIGUNG VON VERBINDUNGSELEMENTEN / FIXATION STANDARD  
 DES ATTACHES / FIJACIÓN ESTÁNDAR DE SUJETADORES / FIXAÇÃO PADRÃO DE FIXADORES / СТАНДАРТНАЯ ФІКСАЦІЯ КРЕПЕЖНЫХ  
 ЭЛЕМЕНТОВ / 紧固件的标准固定 / 패스너의 표준 고정 / ファスナーの標準固定  
 קיבוע תקני של מחברים / التثبيت القياسي للسحابات

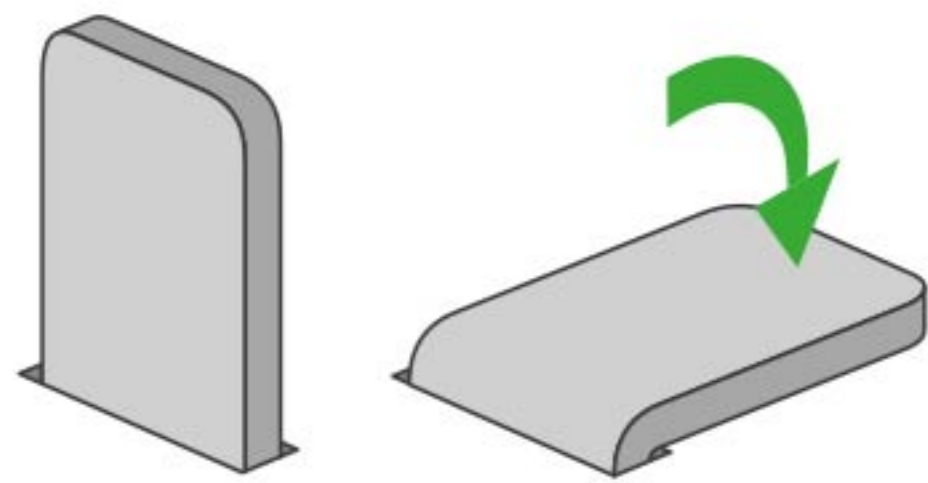

**EN** If there are no additional designations, use the standard fixing method

**UA** Якщо немає додаткових позначень використовуйте стандартний спосіб фіксації

**PL** Jeśli nie ma dodatkowych oznaczeń, użyj standardowej metody mocowania

**IT** Se non sono presenti ulteriori designazioni, utilizzare il metodo di fissaggio standard

**DE** Wenn keine zusätzlichen Bezeichnungen vorhanden sind, verwenden Sie die Standard-Befestigungsmethode

**FR** S'il n'y a pas de désignations supplémentaires, utilisez la méthode de fixation standard

**ES** Si no hay designaciones adicionales, utilice el método de fijación estándar

**PT** Se não houver designações adicionais, use o método de fixação padrão

**RU** Если нет дополнительных обозначений используйте стандартный способ фиксации

**CN** 如果沒有附加名稱，請使用標準固定方法

**KR** 추가 지정이 없는 경우 표준 고정 방법을 사용하십시오

**JP** 追加の指定がない場合は、標準の固定方法を使用してください

**AR** إذا لم تكن هناك تسميات إضافية، فاستخدم طريقة التثبيت القياسية

**HE** אם אין ייעודים נוספים, השתמש בשיטת התיקון הרגילה

Use pliers to bend the fasteners / Для загнути кріпильних елементів використовуйте плоскогубці / Użyj szczypięć do wygięcia łączników / Usa le pinze per piegare gli elementi di fissaggio / Verwenden Sie eine Zange, um die Befestigungselemente zu biegen / Utilisez des pinces pour plier les attaches / Utilice unos alicates para doblar los sujetadores / Use um alicate para dobrar os fechos / Для загиба крепежных элементов используйте плоскогубцы / 使用钳子弯曲紧固件 / 펜치를 사용하여 패스너를 구부립니다 / ペンチを使用して留め具を曲げます。  
 השתמש בצבת כדי לכופף את המחברים / استخدم الزبدية لثني السحابات

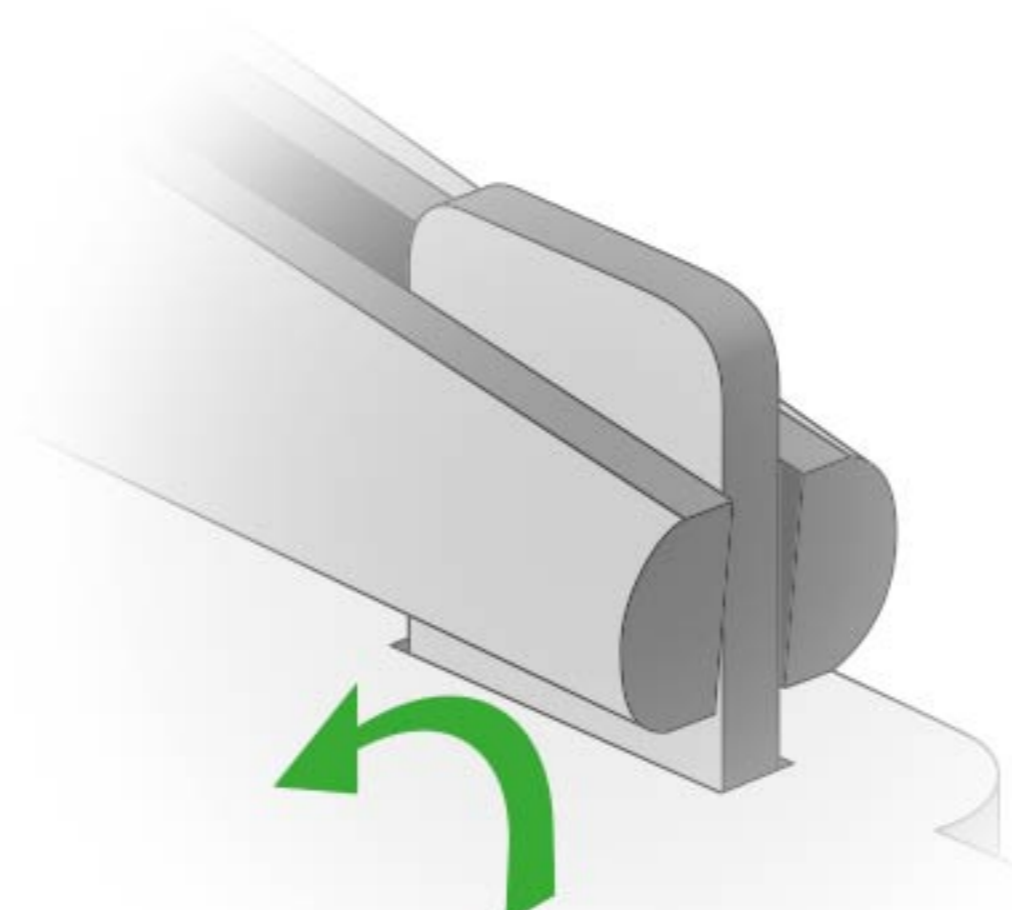

**EN** **WARNING!** To avoid a short circuit, the contact points must not touch the product body.

**UA** **УВАГА!** Щоб уникнути короткого замикання місця контактів не повинні торкатися корпусу виробу.

**PL** **UWAGA!** Aby uniknąć zwarcia, styki nie mogą dotykać korpusu produktu.

**IT** **AVVERTENZE!** Per evitare cortocircuiti, i punti di contatto non devono toccare il corpo del prodotto.

**DE** **ACHTUNG!** Um einen Kurzschluss zu vermeiden, dürfen die Kontaktstellen den Produktkörper nicht berühren.

**FR** **ATTENTION!** Pour éviter un court-circuit, les points de contact ne doivent pas toucher le corps du produit.

**ES** **¡ATENCIÓN!** Para evitar un cortocircuito, los puntos de contacto no deben tocar el cuerpo del producto.

**PT** **ATENÇÃO!** Para evitar um curto-circuito, os pontos de contacto não devem tocar o corpo do produto.

**RU** **ВНИМАНИЕ!** Во избежание короткого замыкания места контактов не должны касаться корпуса изделия

**CN** **注意!** 為避免短路，接觸點不得接觸產品主體。

**KR** **경고!** 단락을 방지하려면 접점이 제품 본체에 닿지 않아야 합니다

**JP** **ご注意!** 短絡を防ぐために、接点が製品本体に触れないようにする必要があります。

**AR** **تحذير!** لتجنب حدوث ماس كهربائي، يجب ألا تلمس نقاط الاتصال جسم المنتج

**HE** **אזהרה!** כדי למנוע קצר חשמלי, אסור שנקודות המגע ייגעו בגוף המוצר

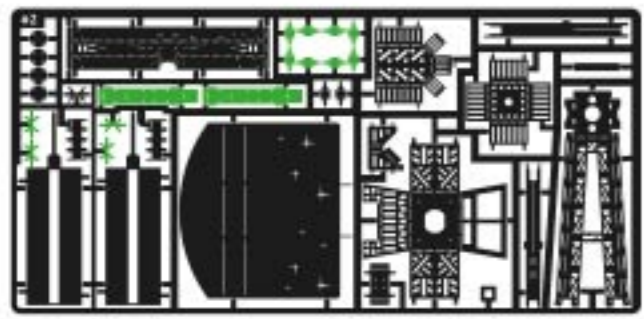

#2

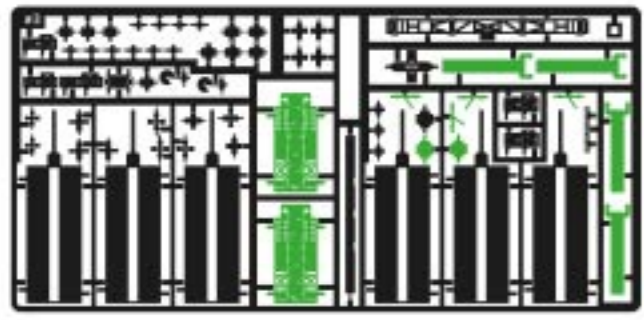

#3

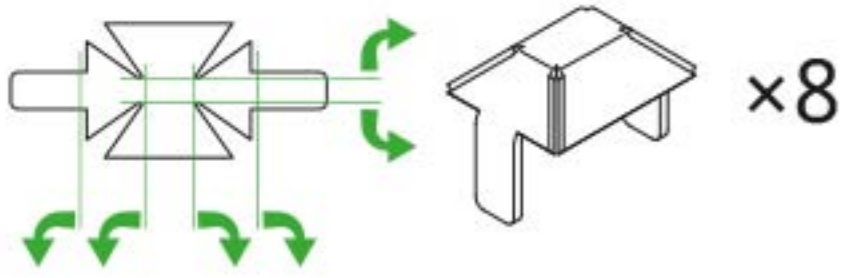

x8

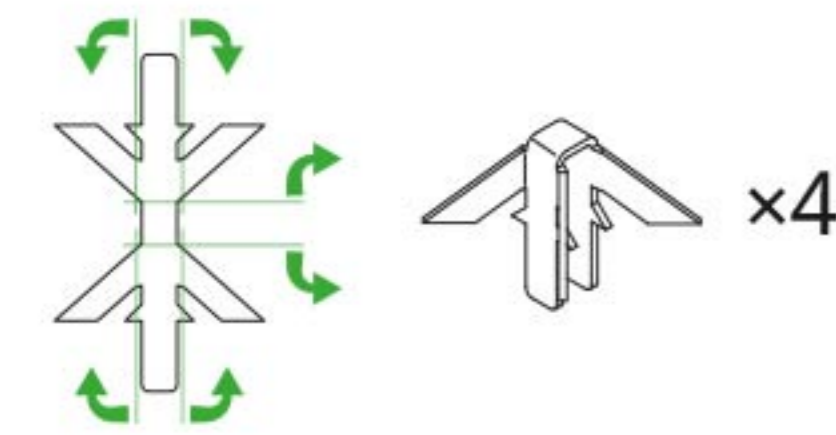

x4

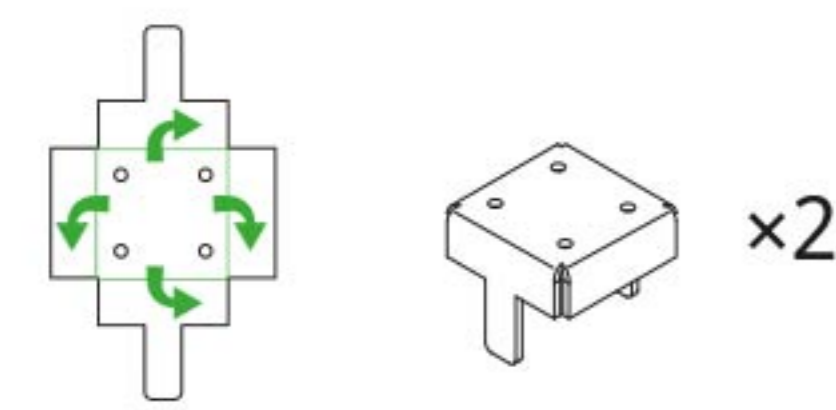

x2

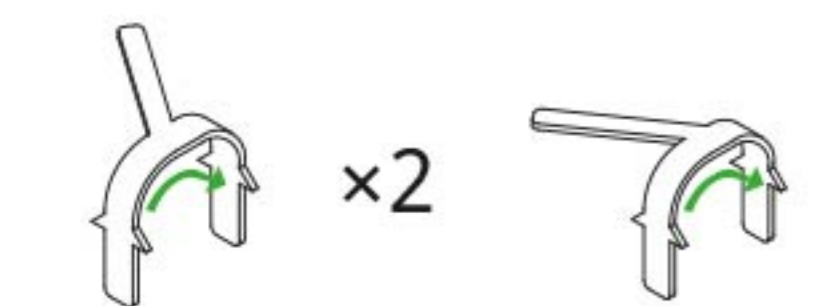

x2

x2

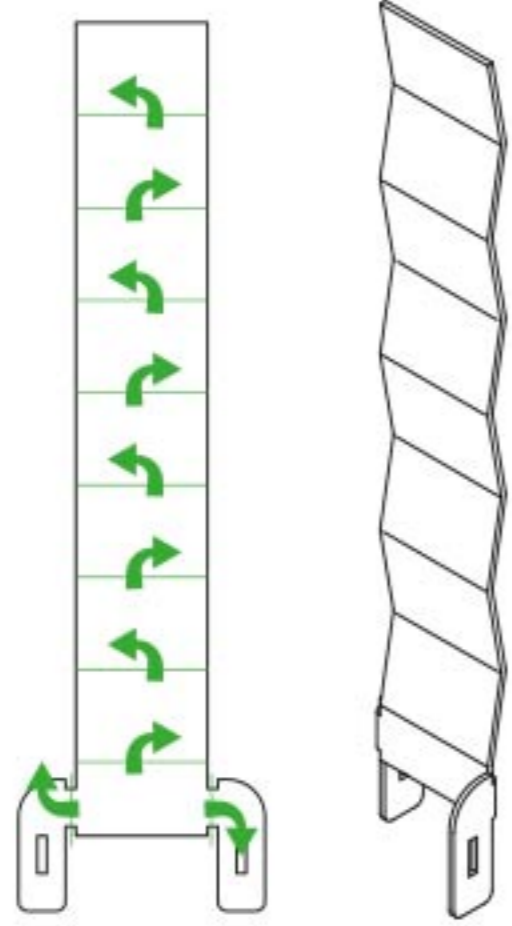

x4

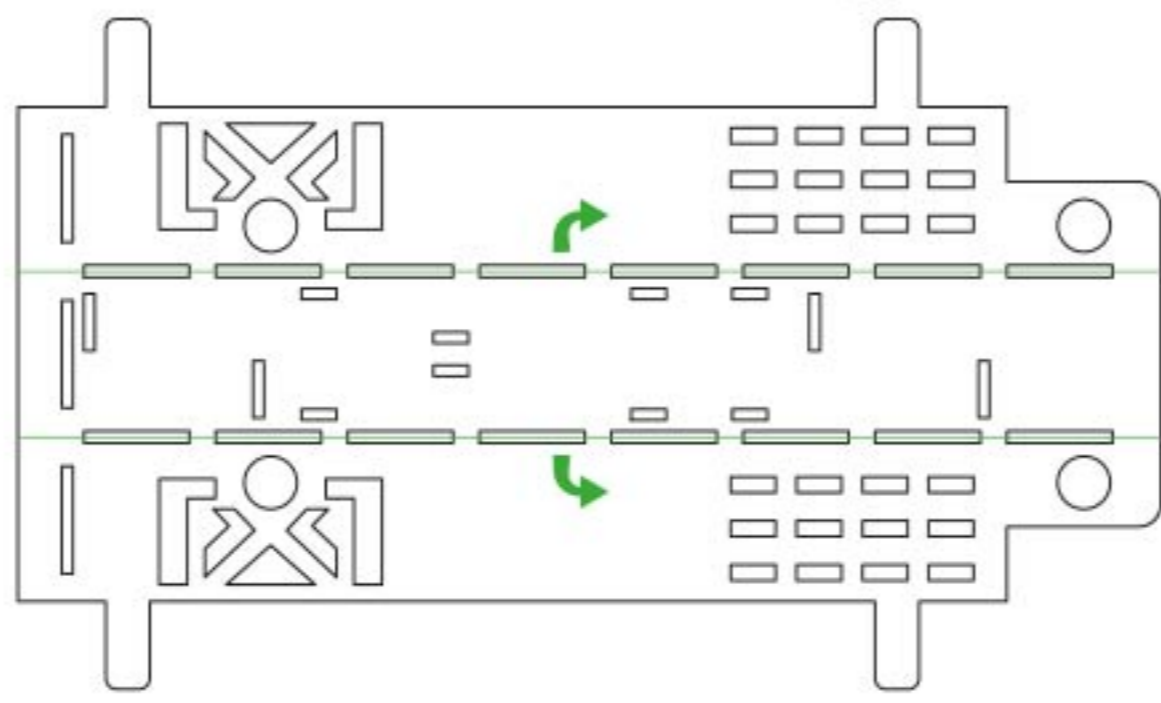

x2

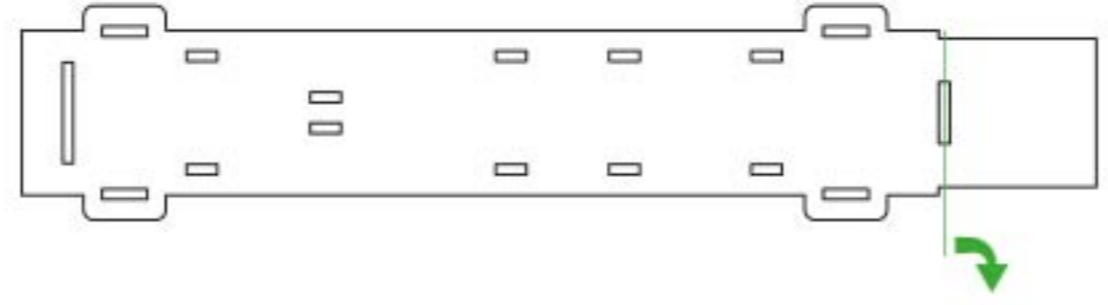

x2

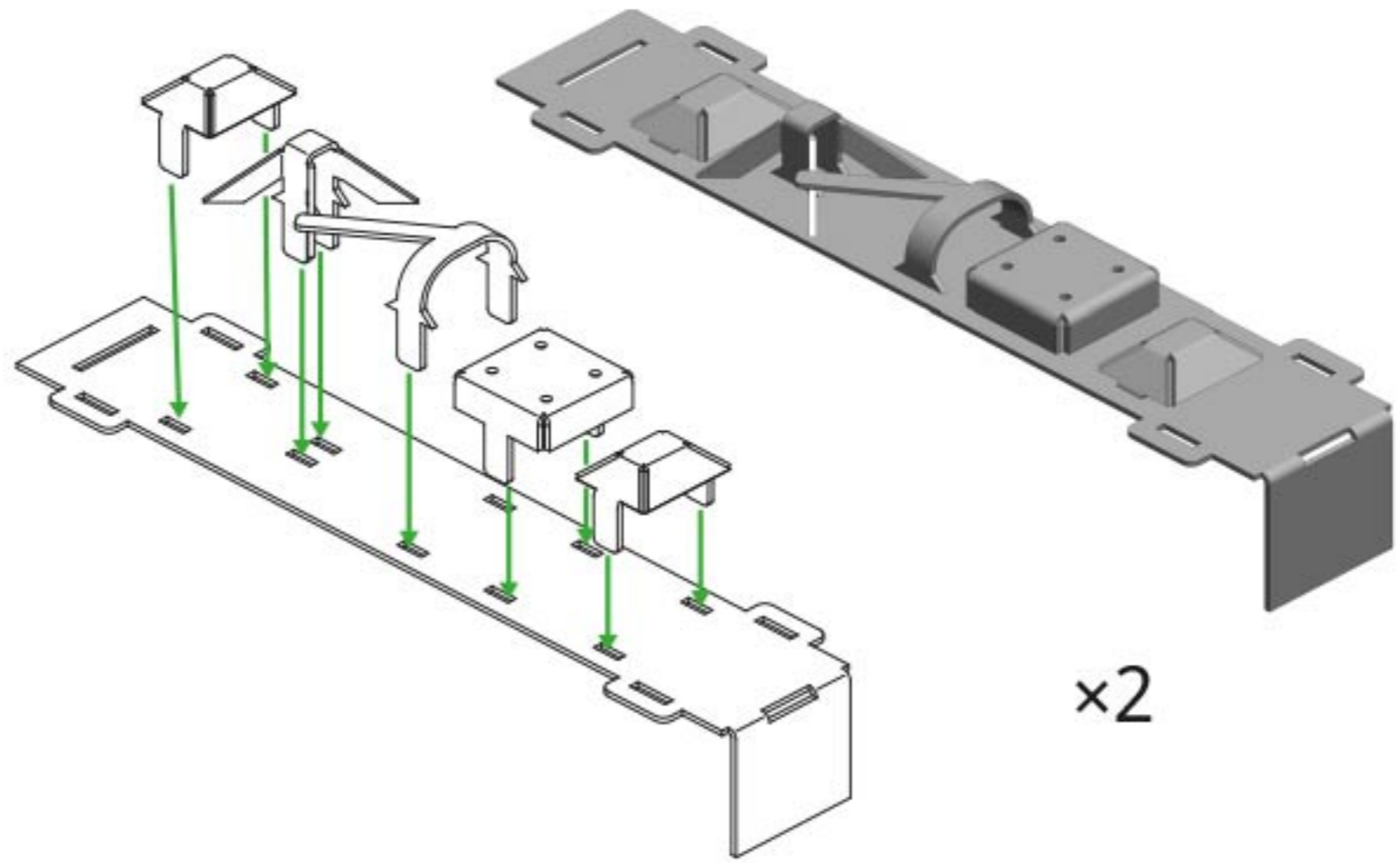

x2

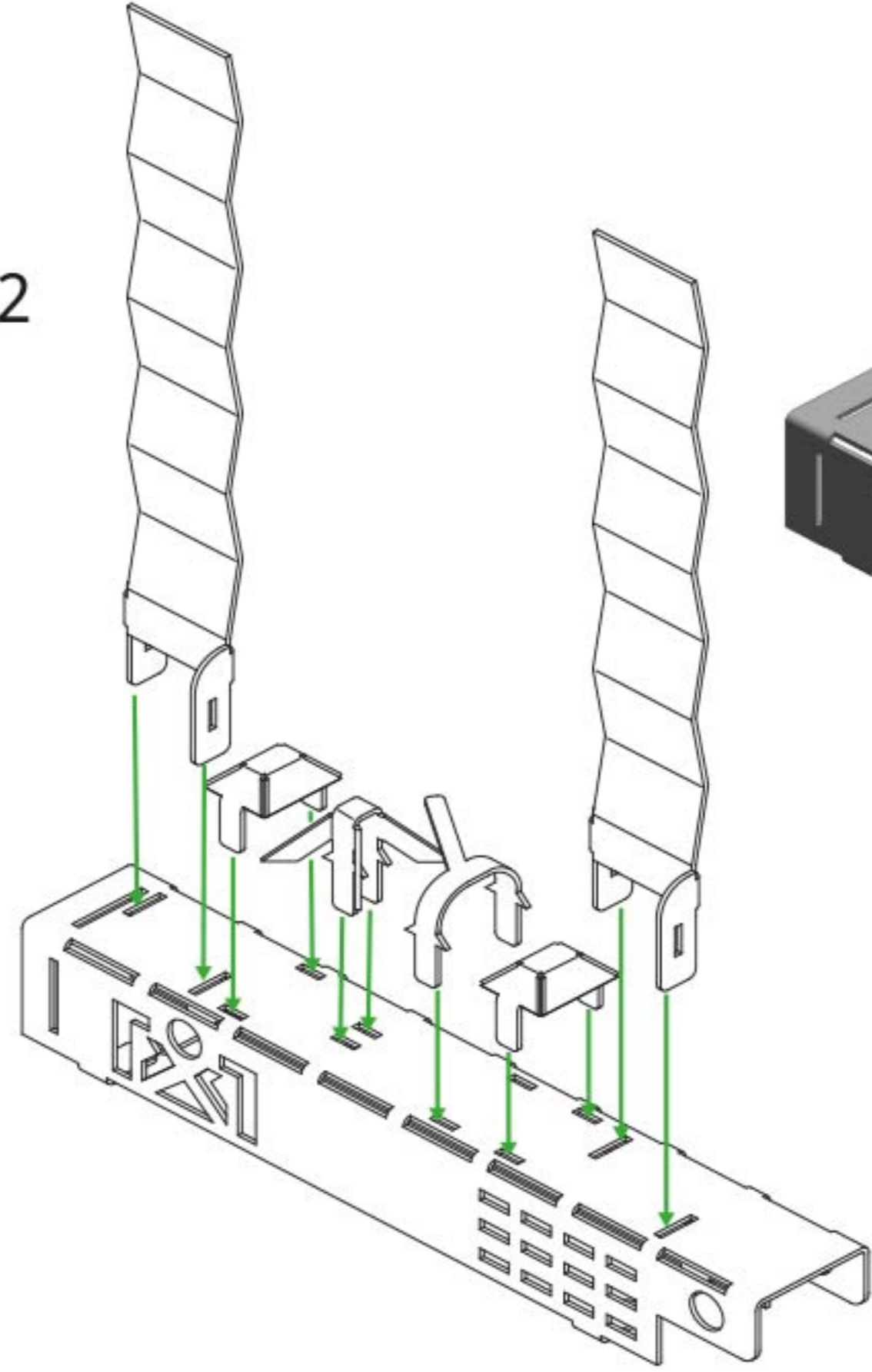

x2

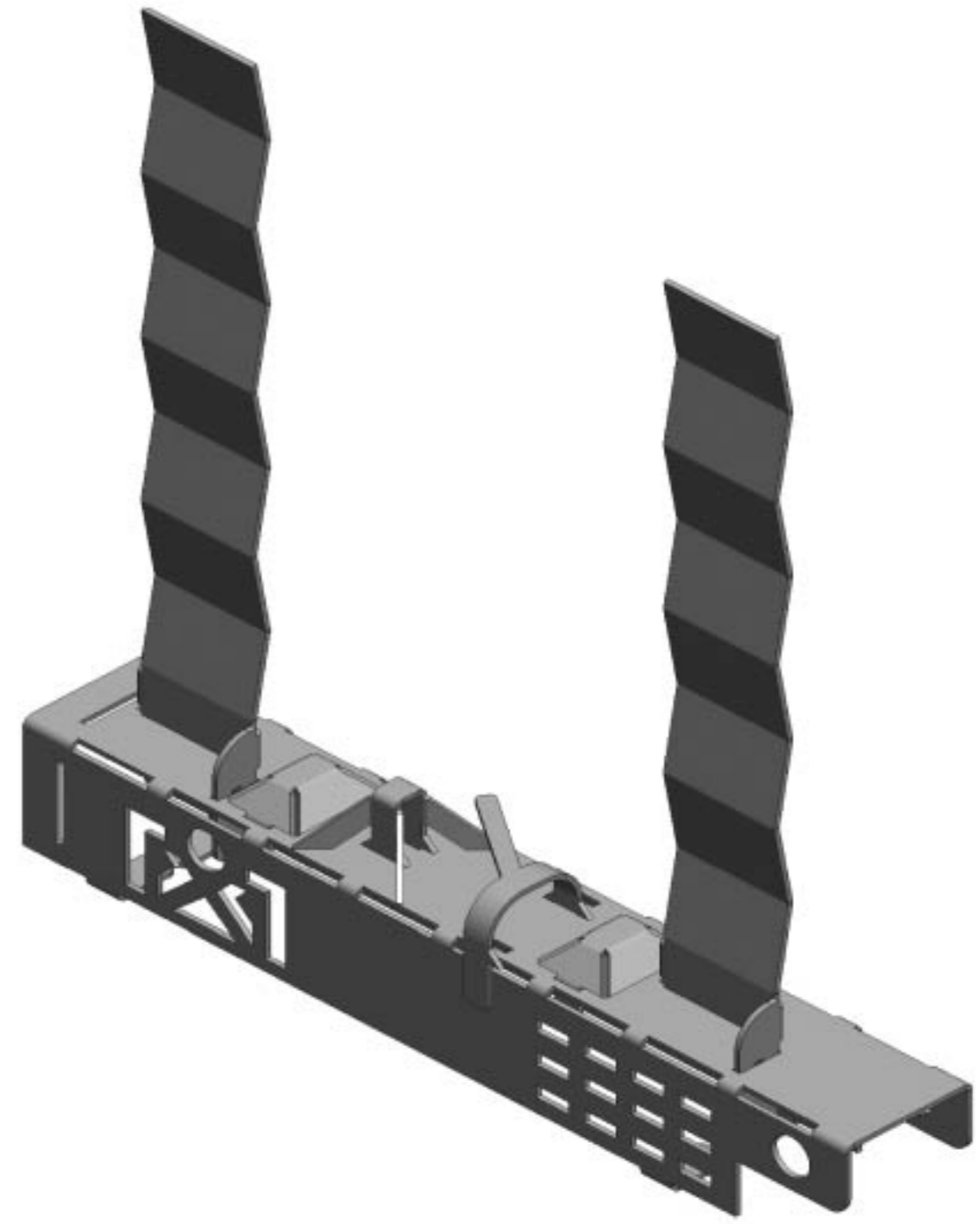

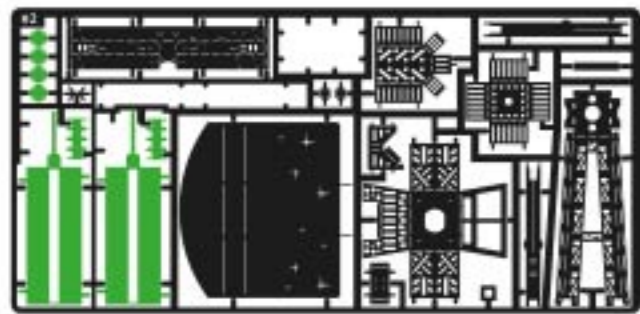

#2

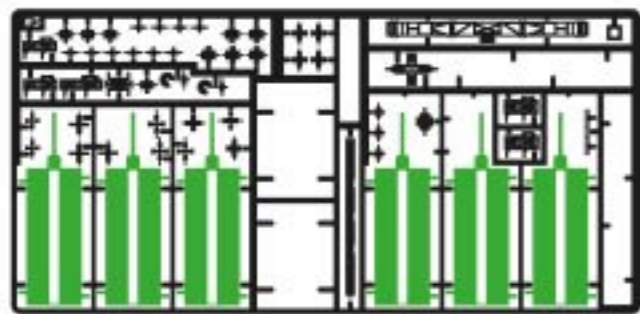

#3

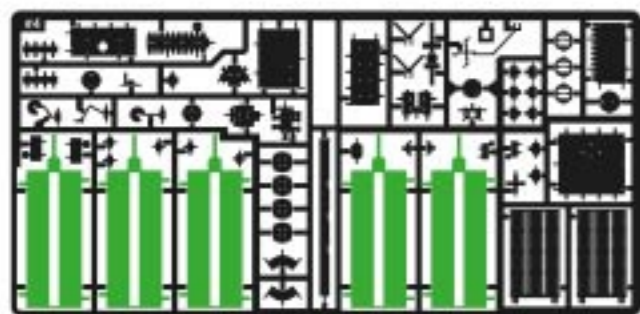

#4

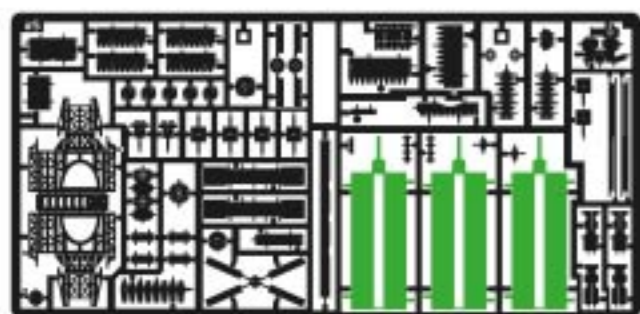

#5

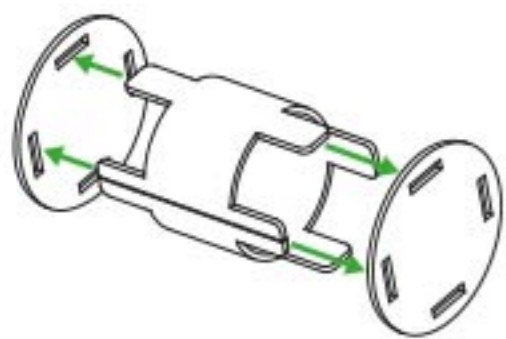
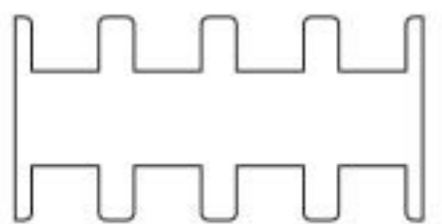

x2

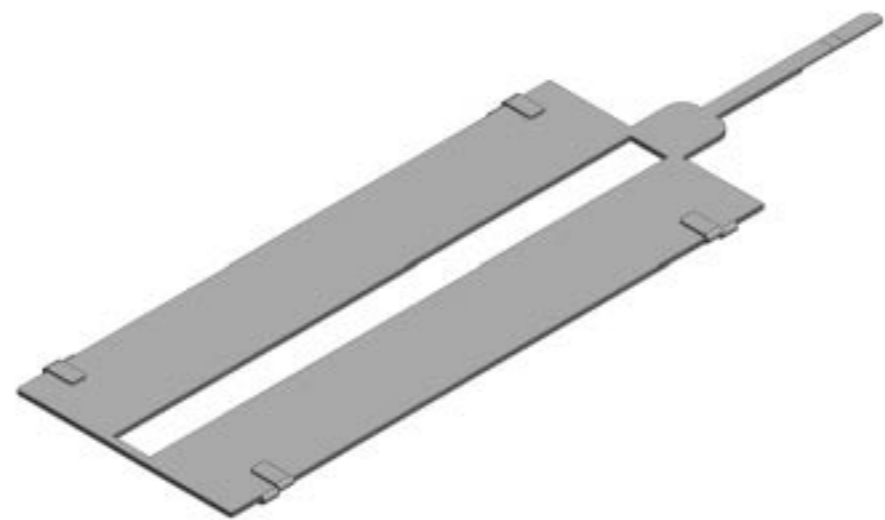
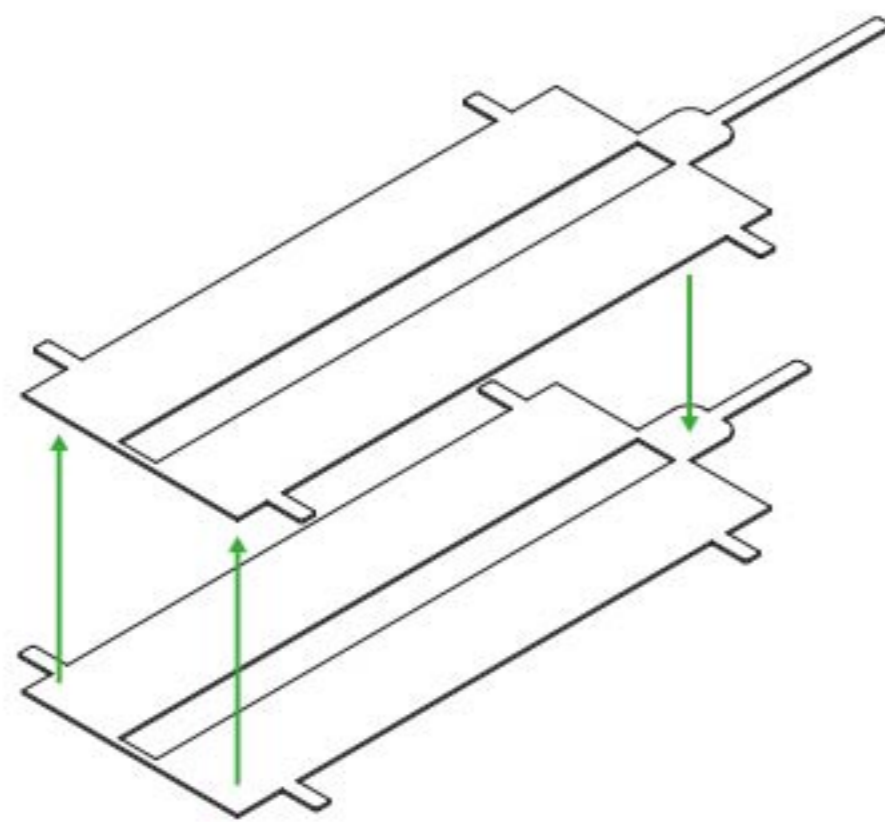

x8

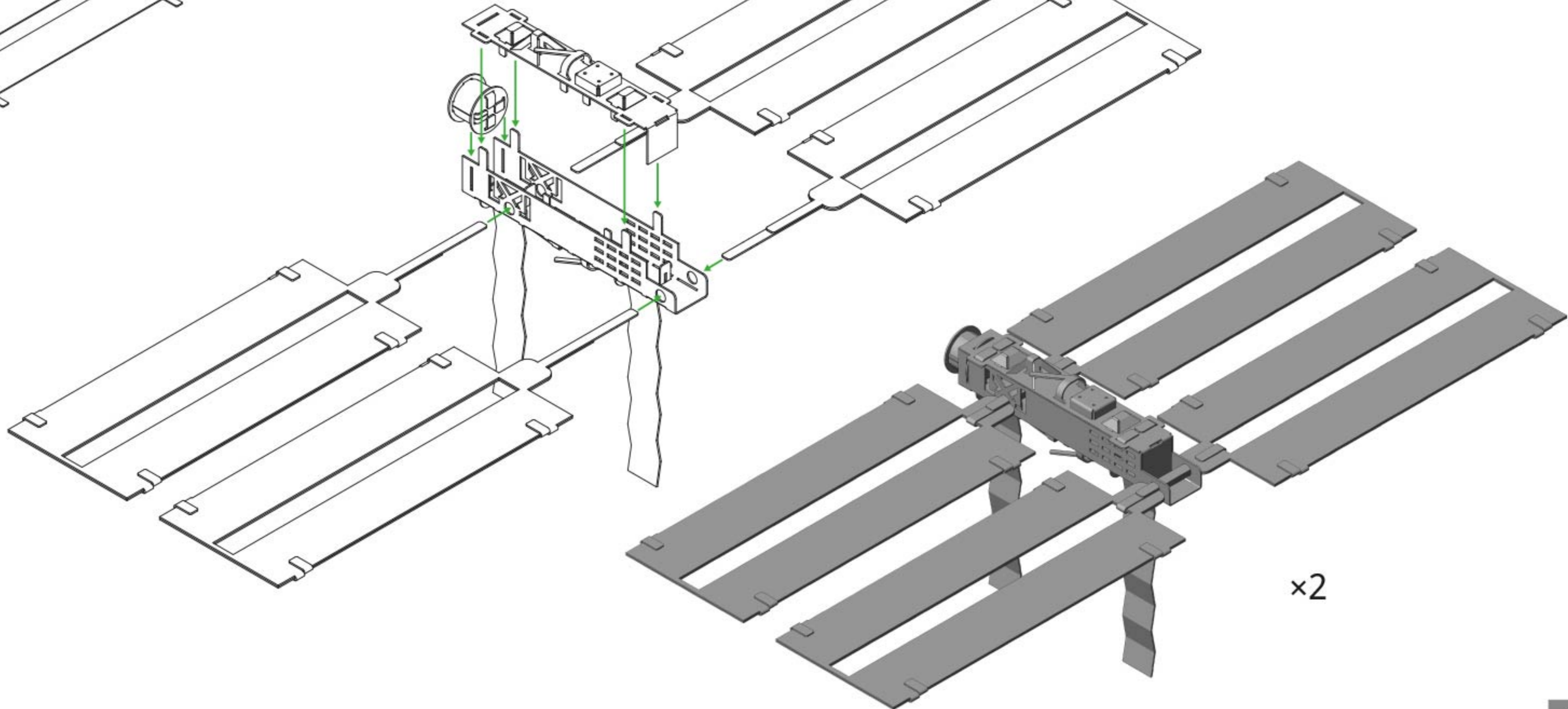

x2

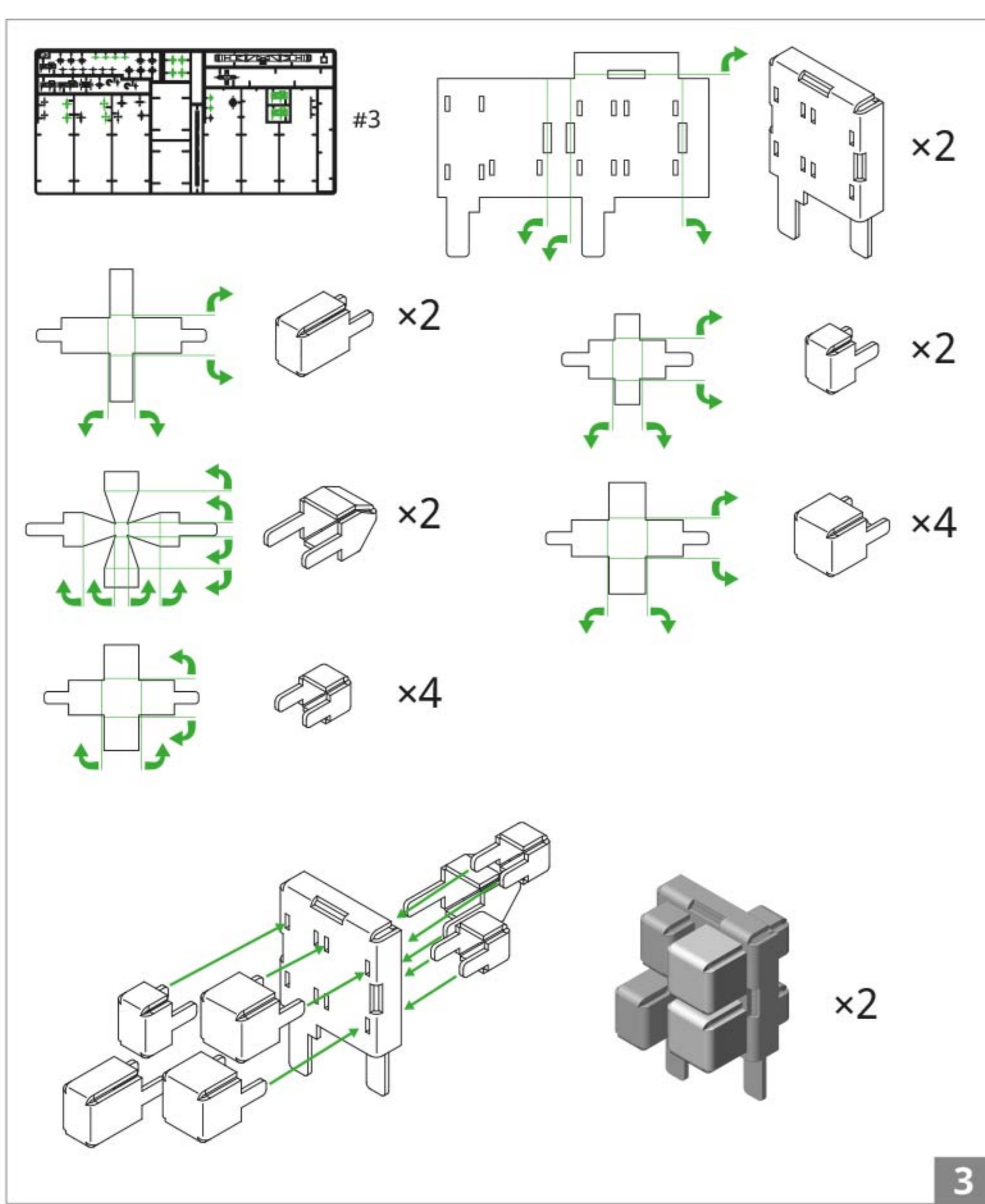

3

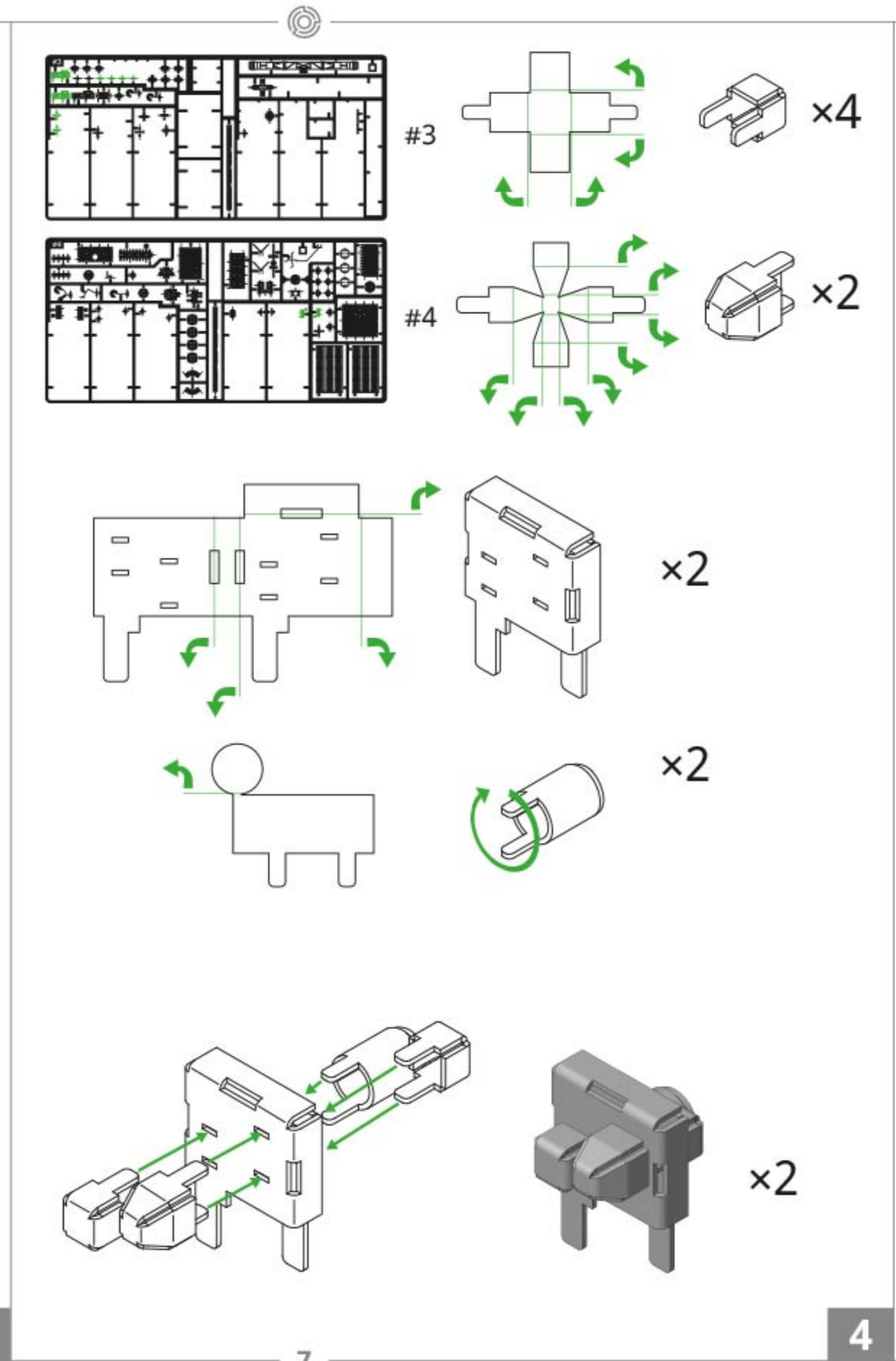

4

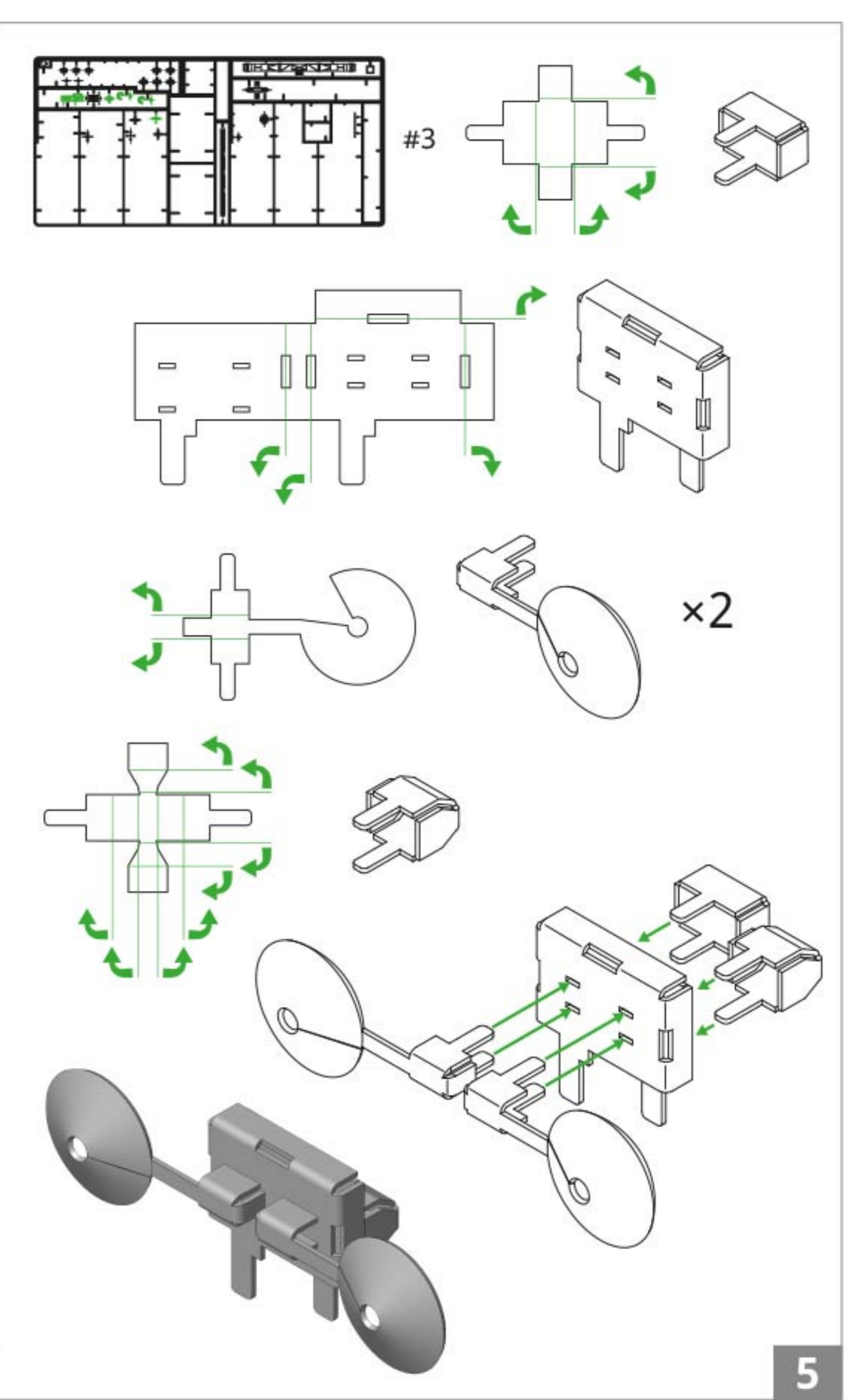

5

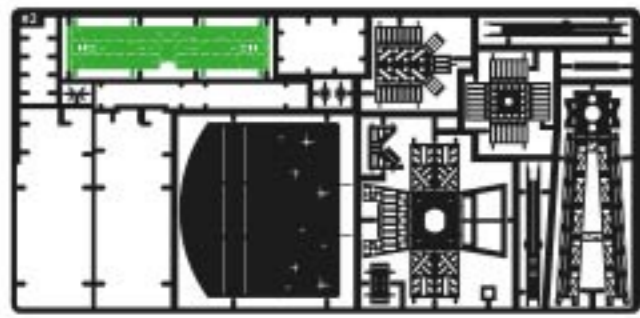

#2



#3

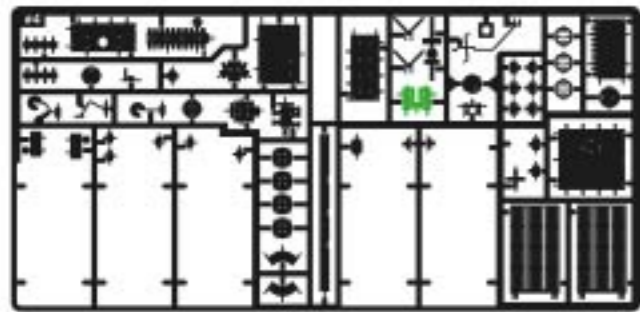

#4

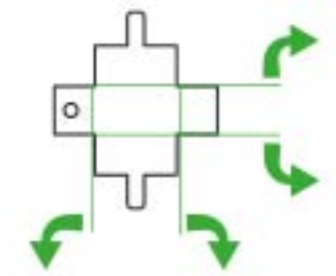
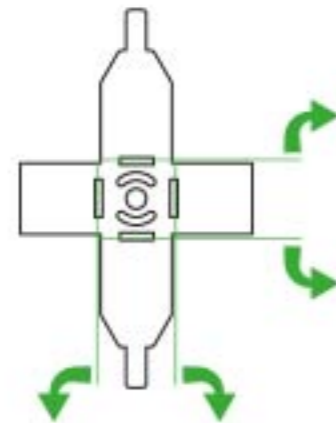
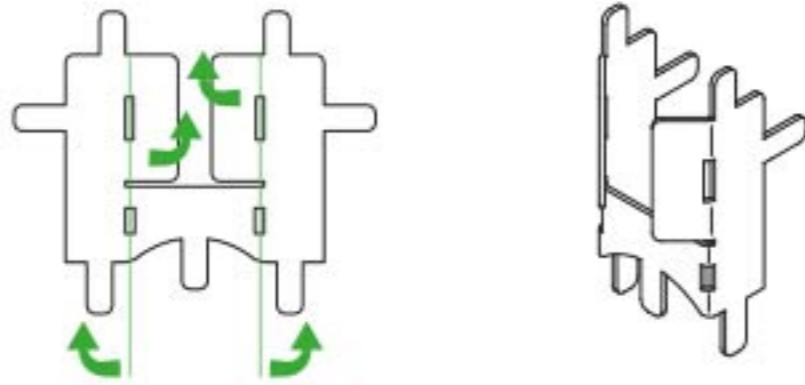
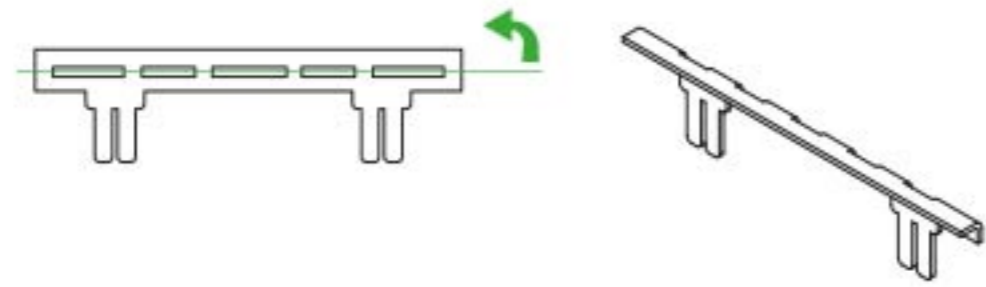

x4

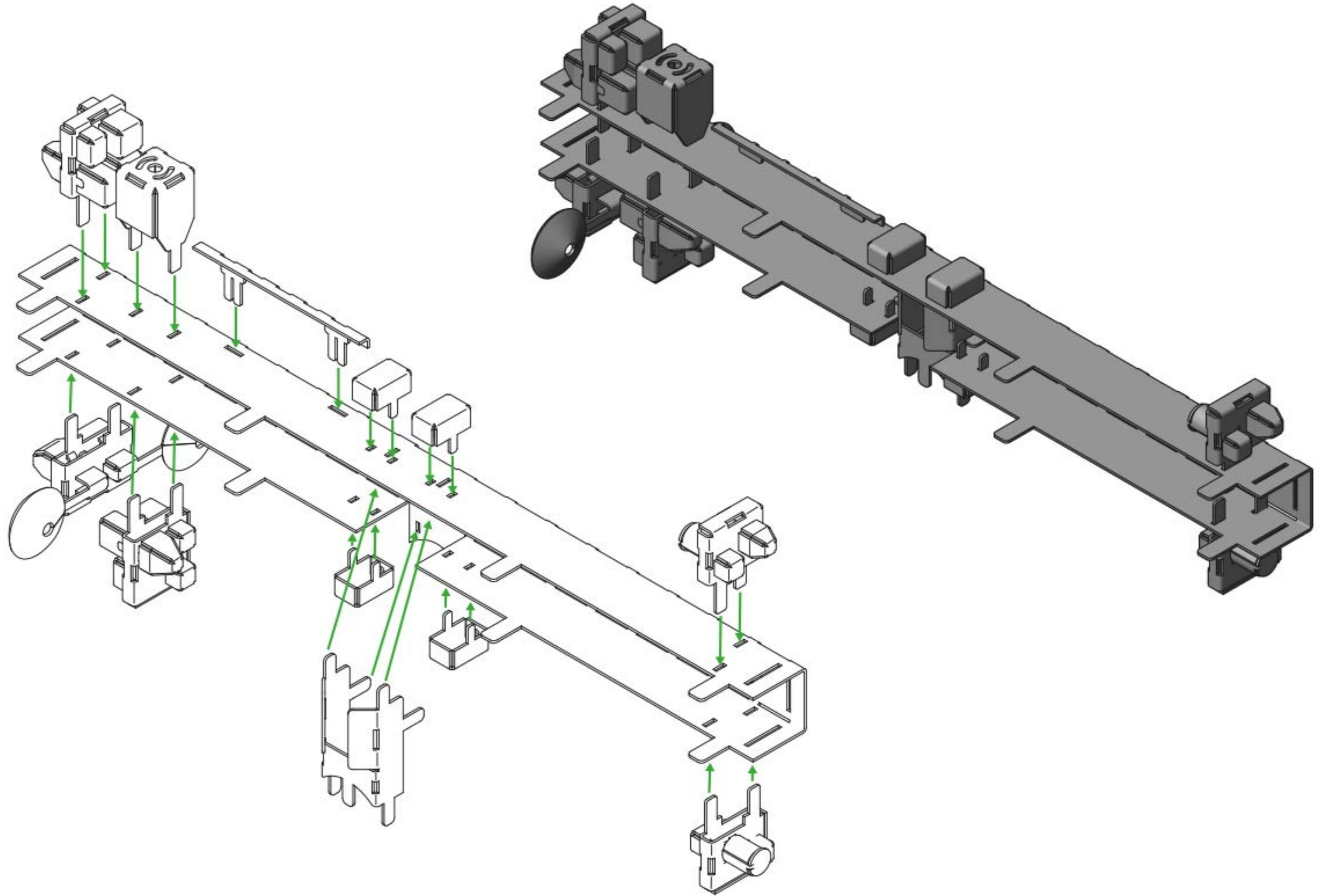
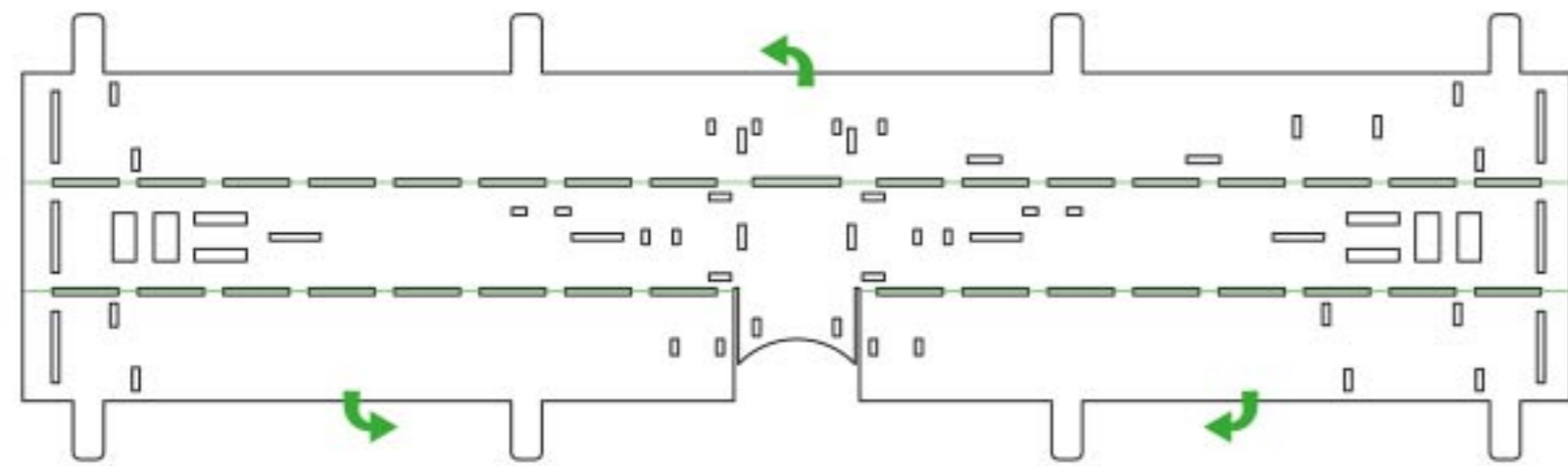



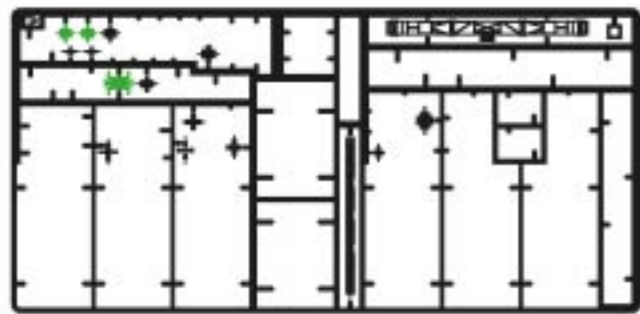

#3

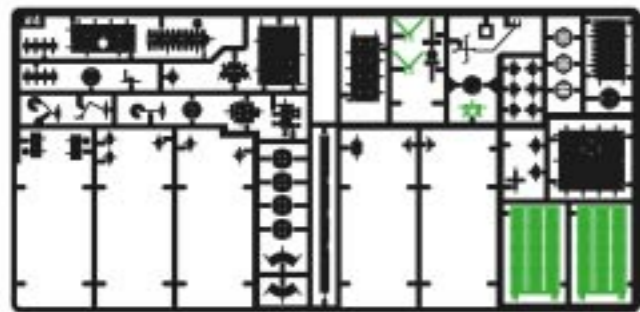

#4

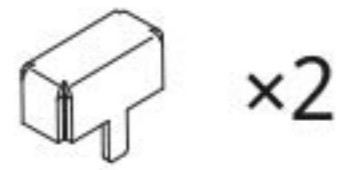
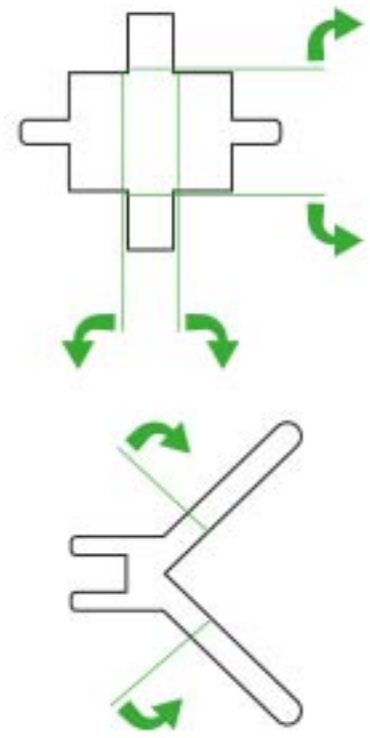

x2



x2

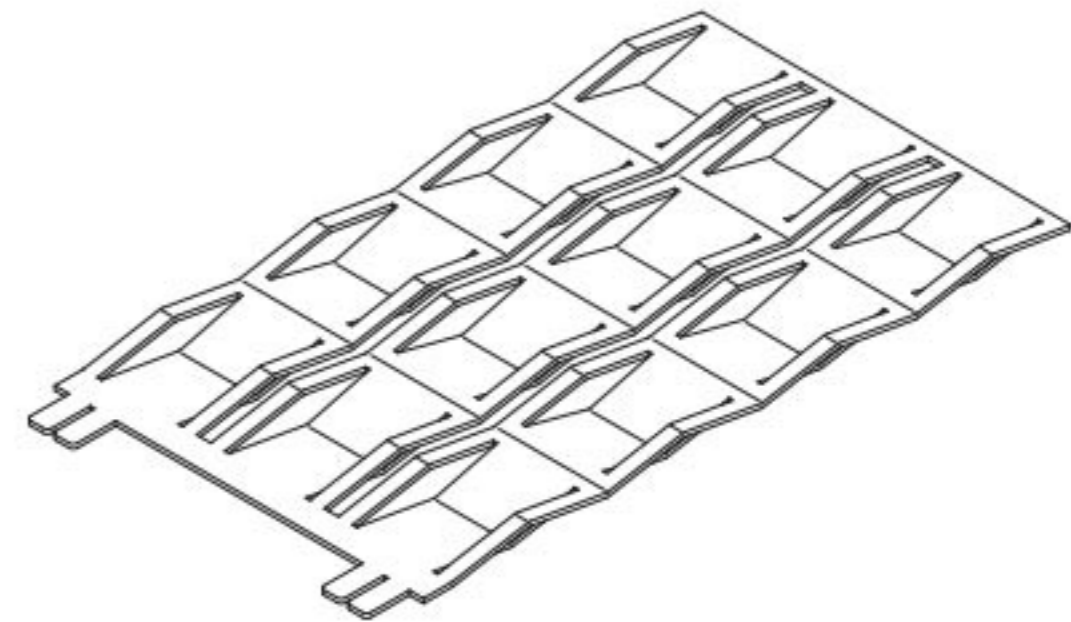
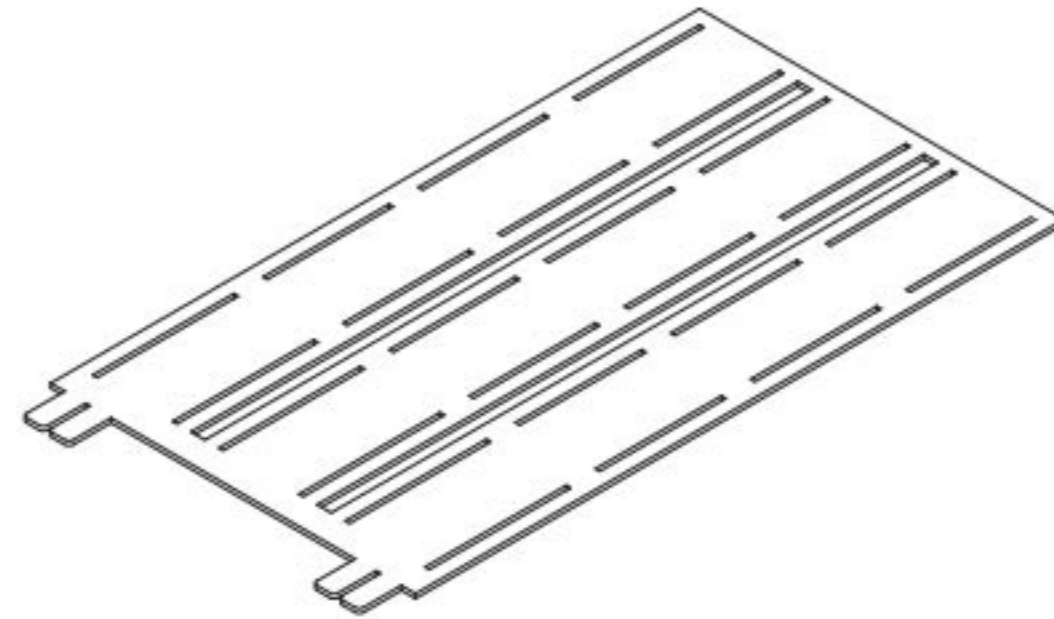

x2

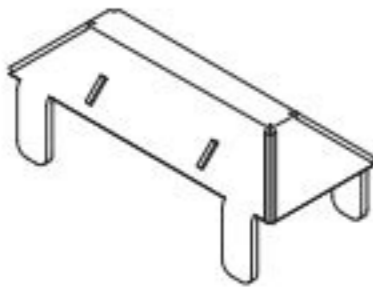
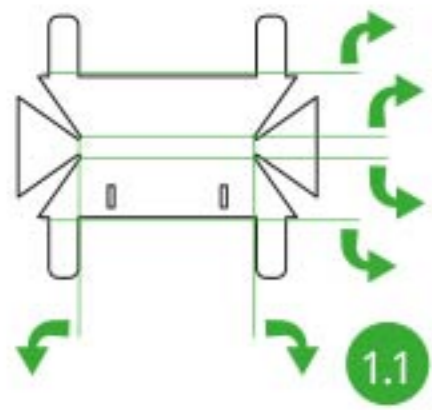

1.1

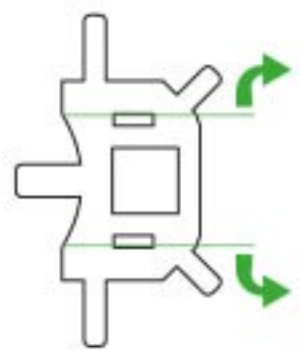

1.2

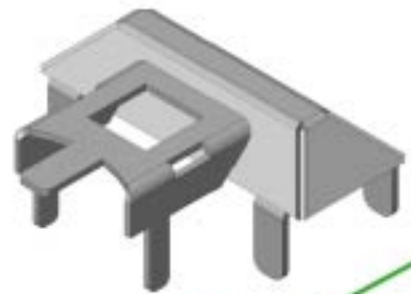
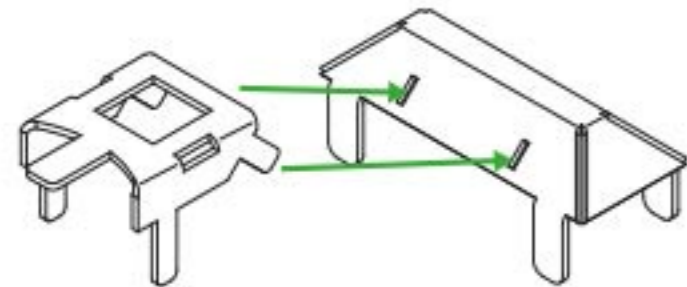

1.3

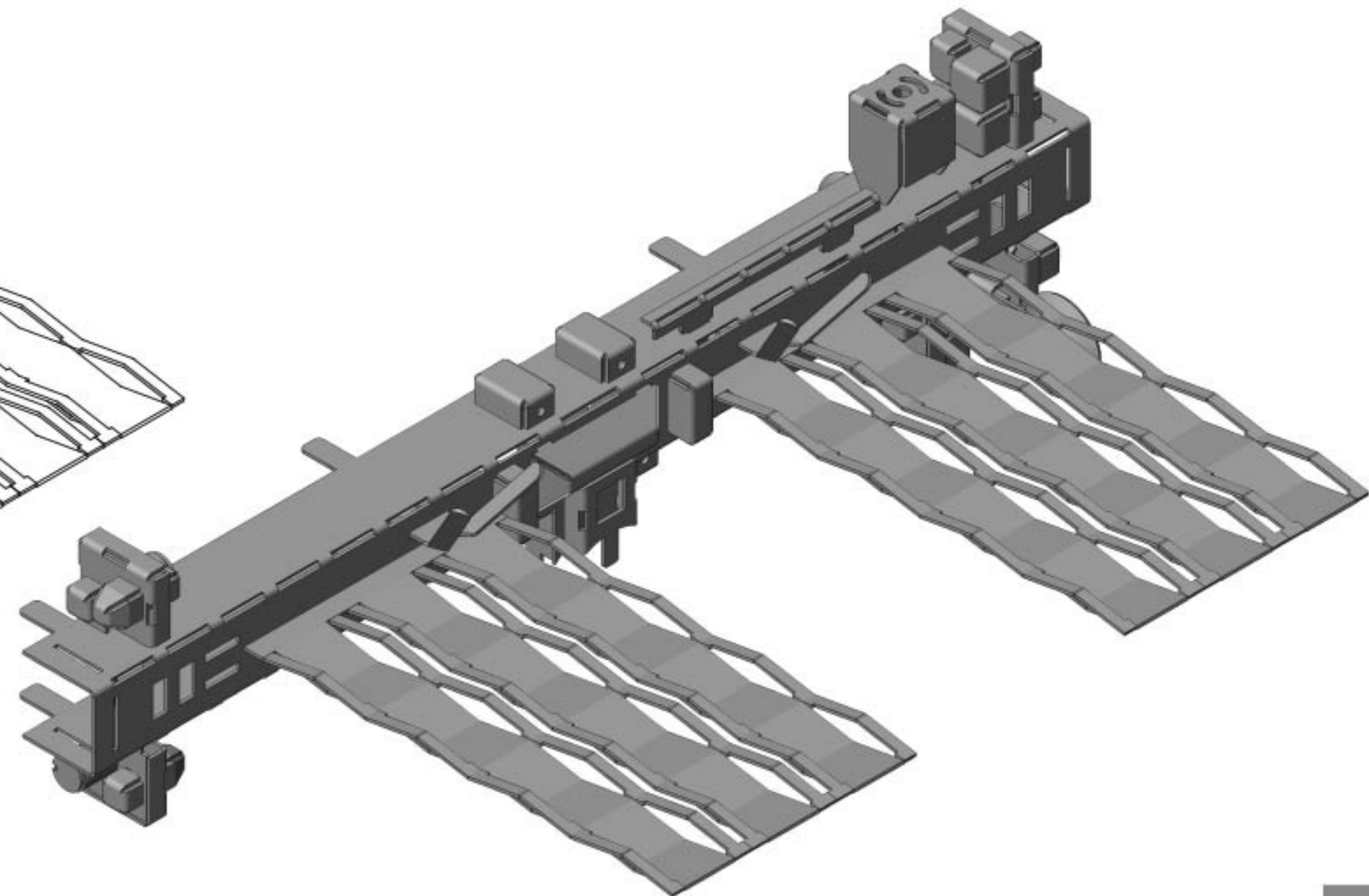
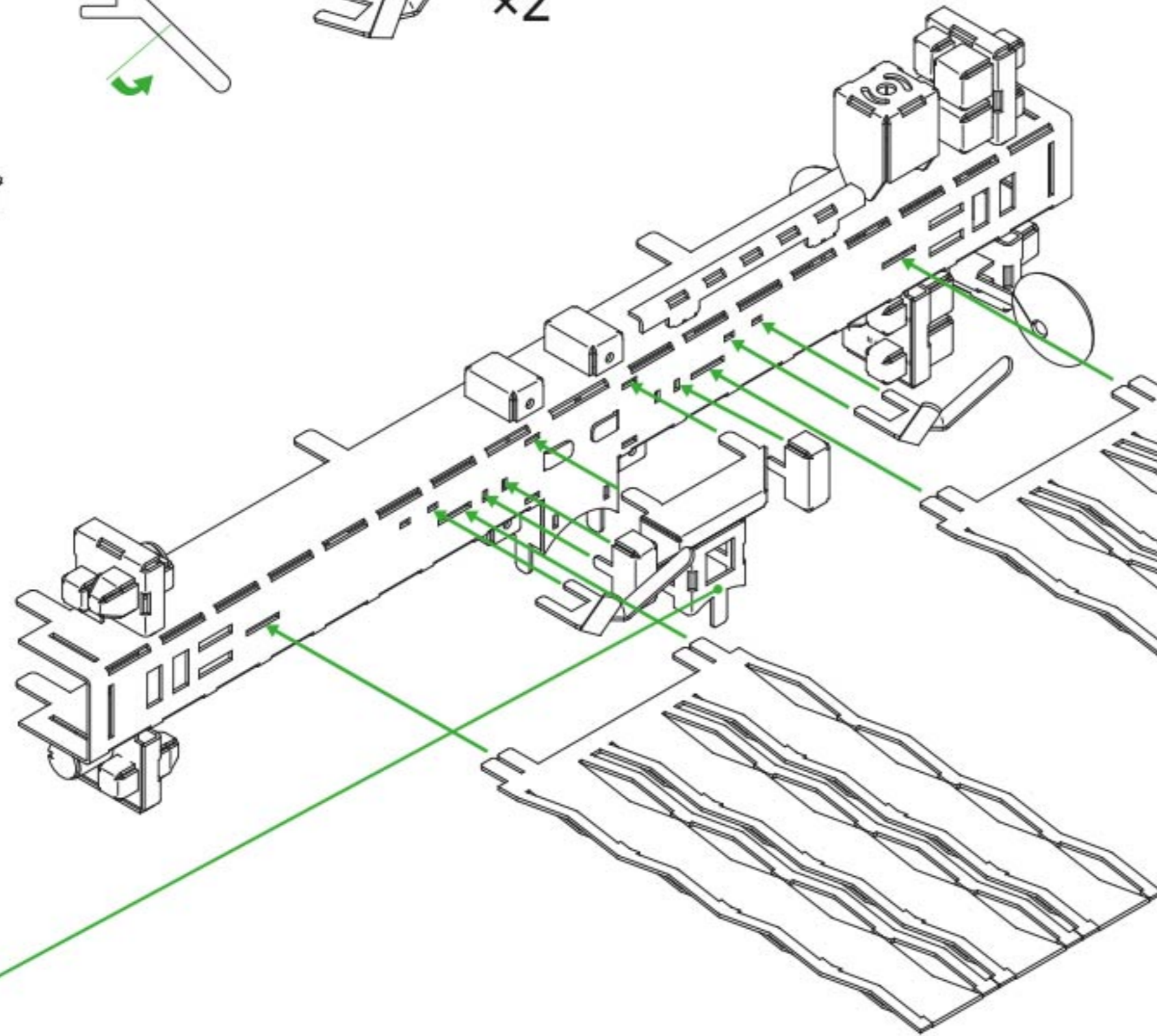

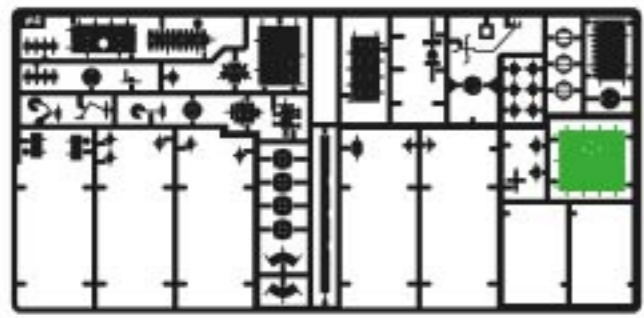

#4

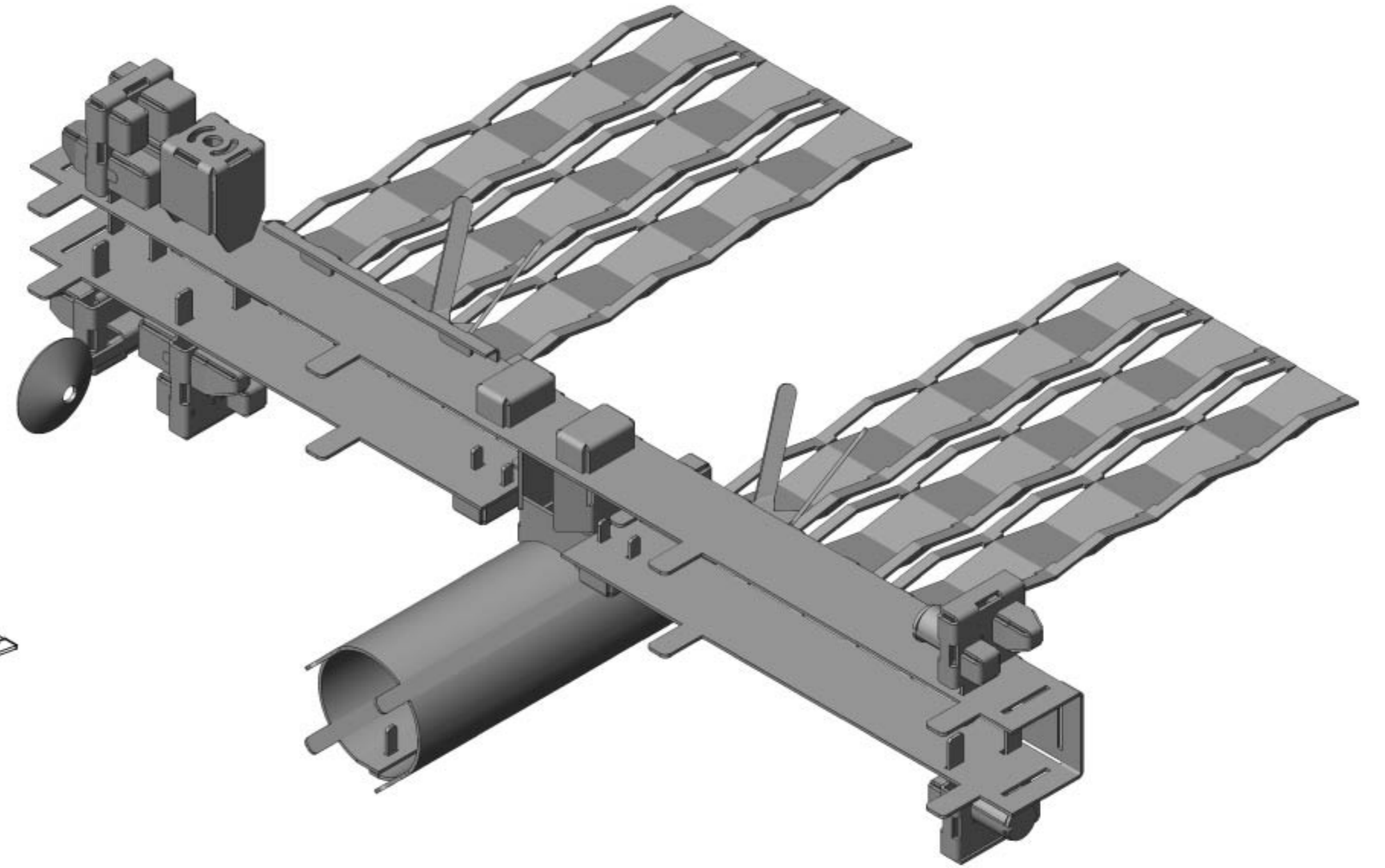
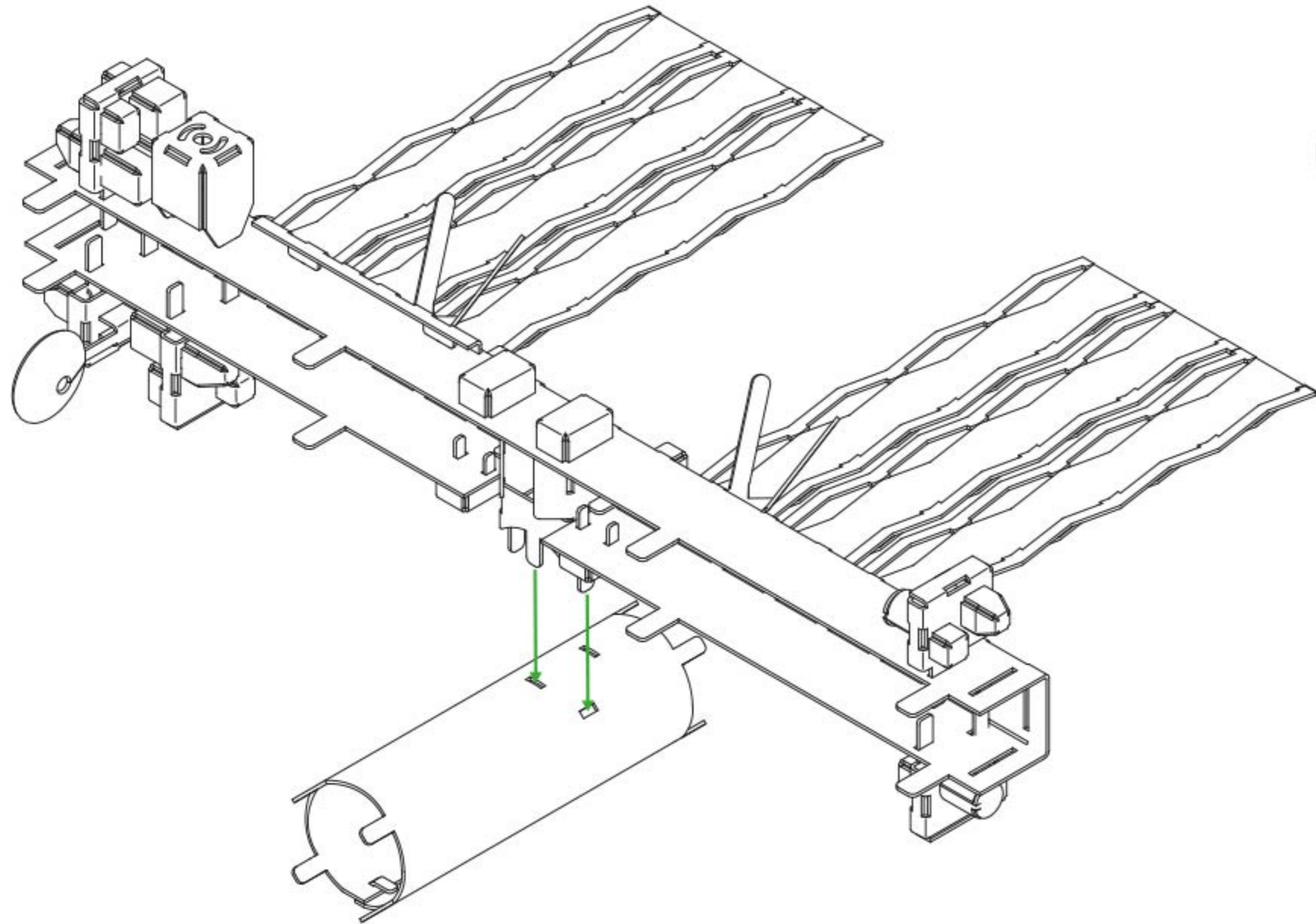
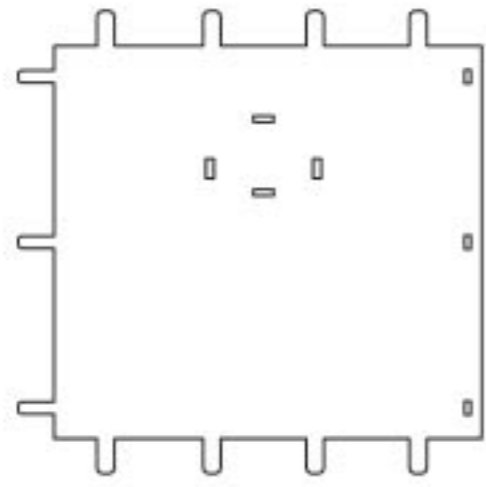

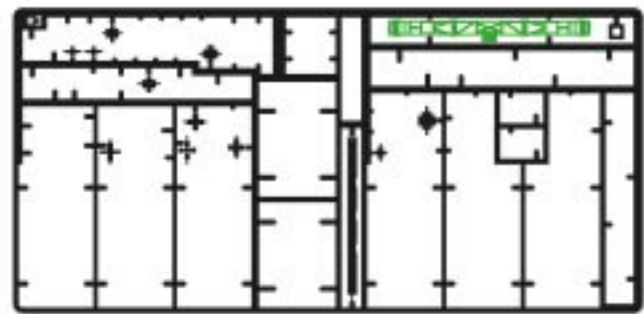

#3

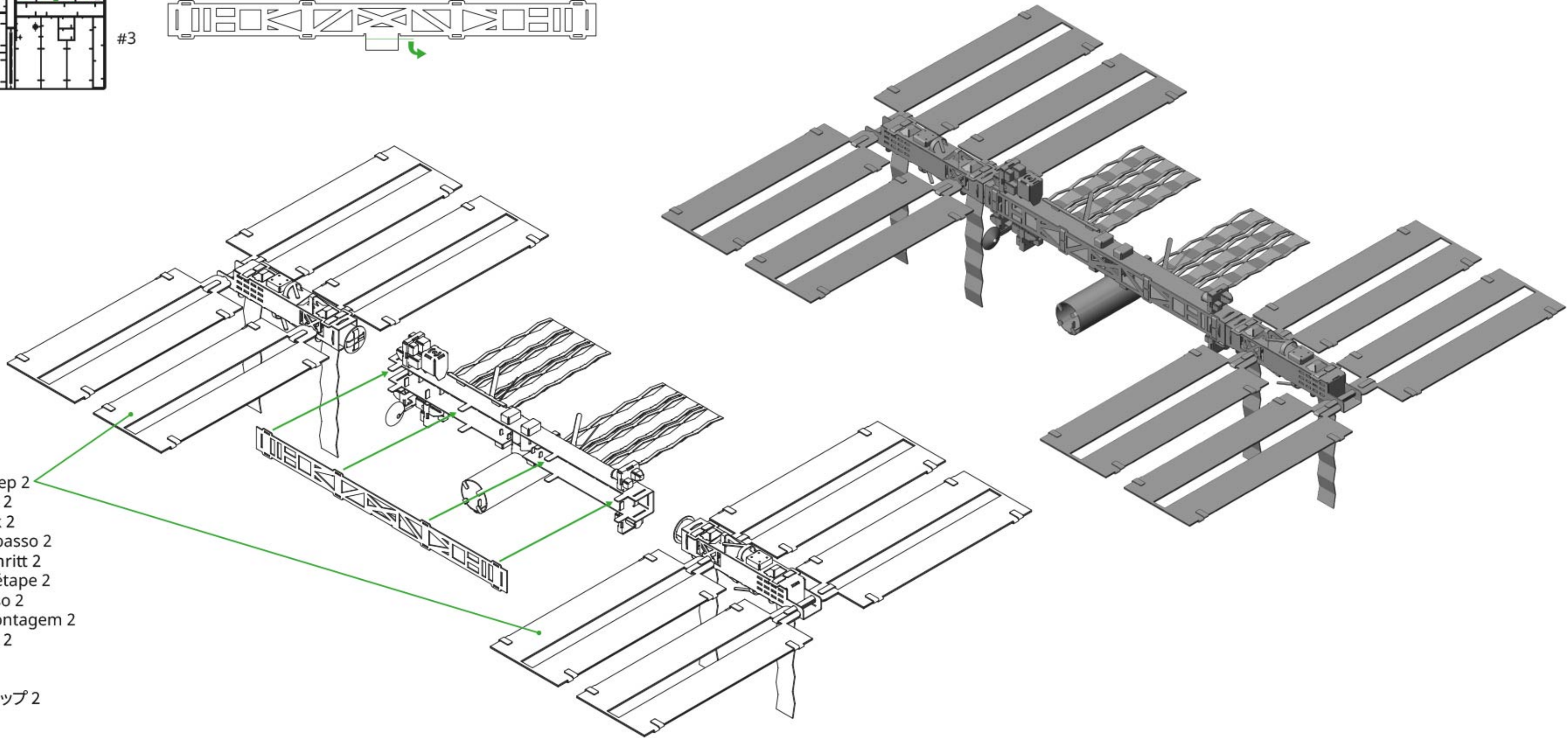
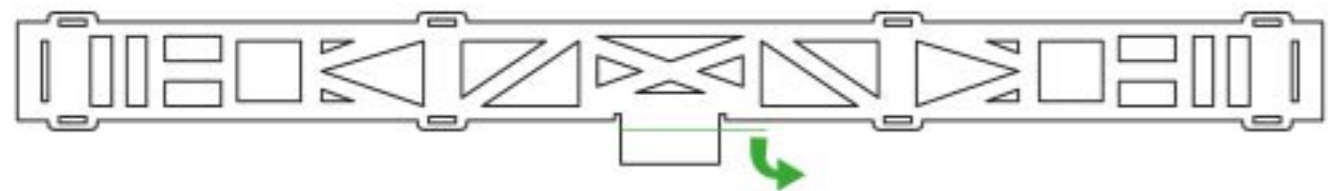

Assembly step 2  
 36ipka krok 2  
 Montaż krok 2  
 Assemblea passo 2  
 Montage schritt 2  
 Assemblée étape 2  
 Montaje paso 2  
 Etapa de montagem 2  
 Сборка шаг 2  
 集会 步骤2  
 조립 2 단계  
 組み立てステップ 2  
 خطوة التجميع 2  
 שלב הרכבה 2

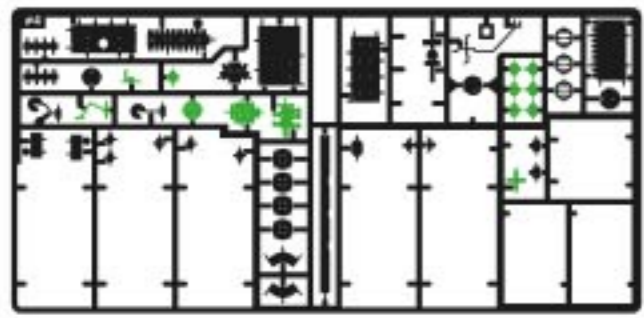

#4

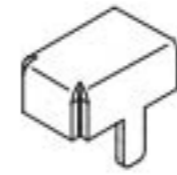
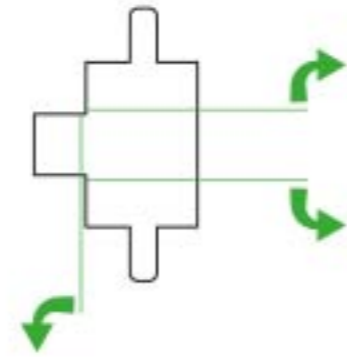
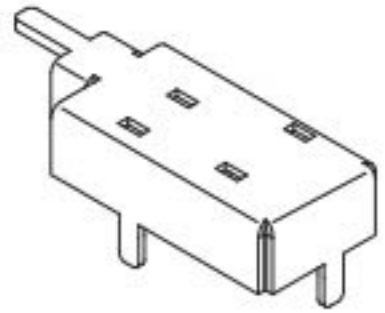
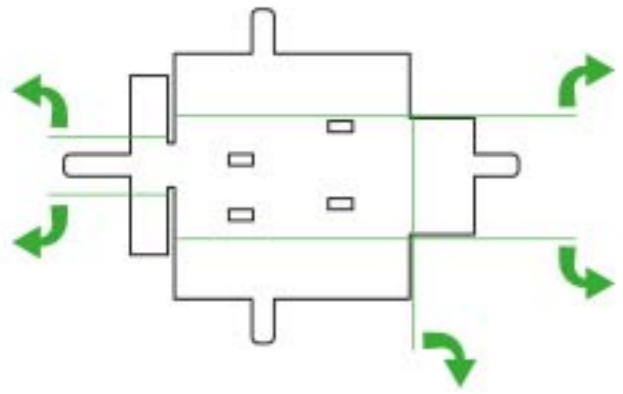
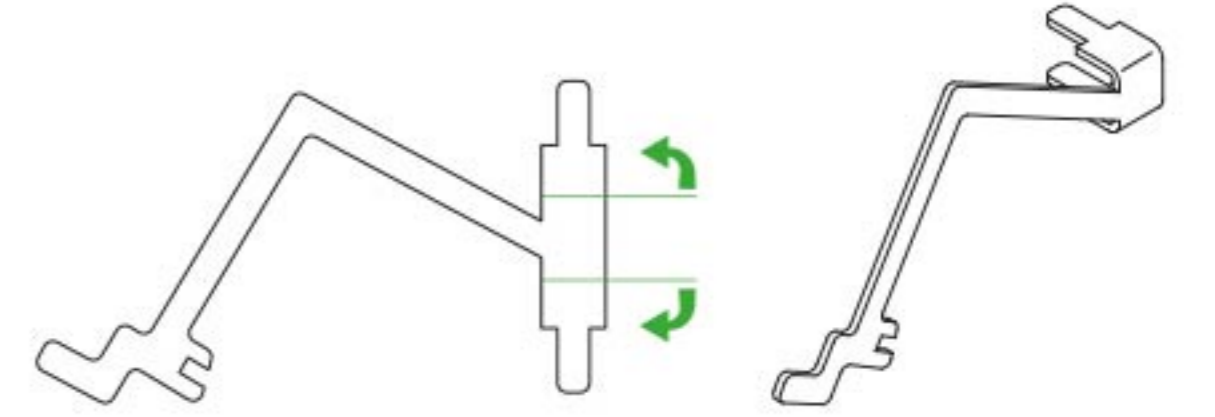
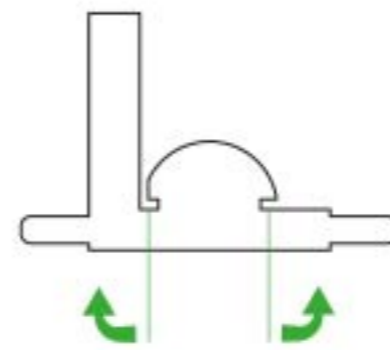
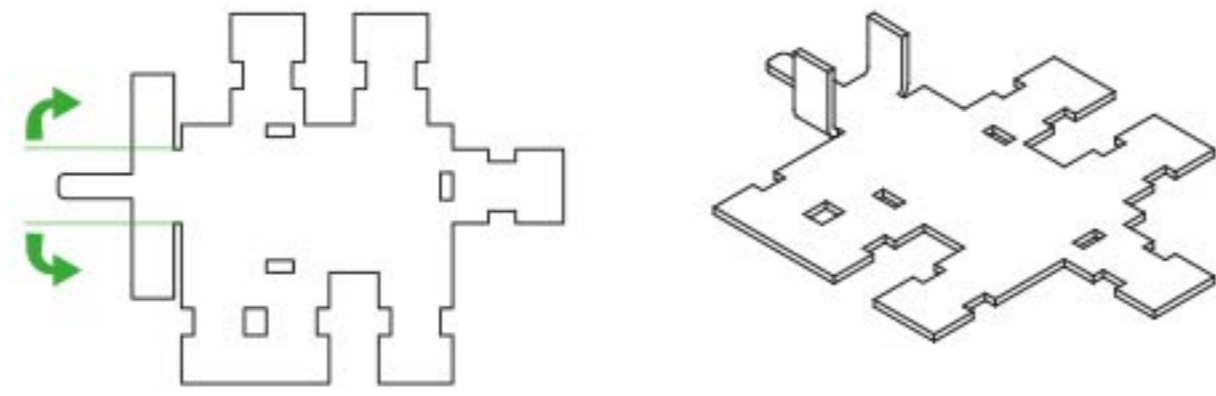

x6

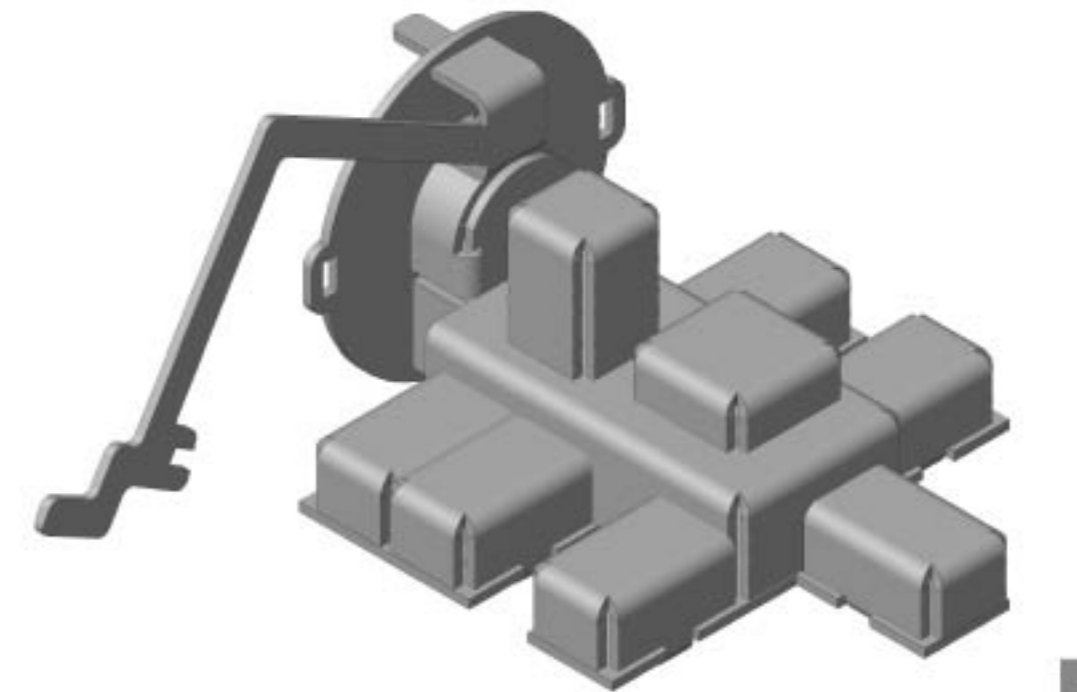
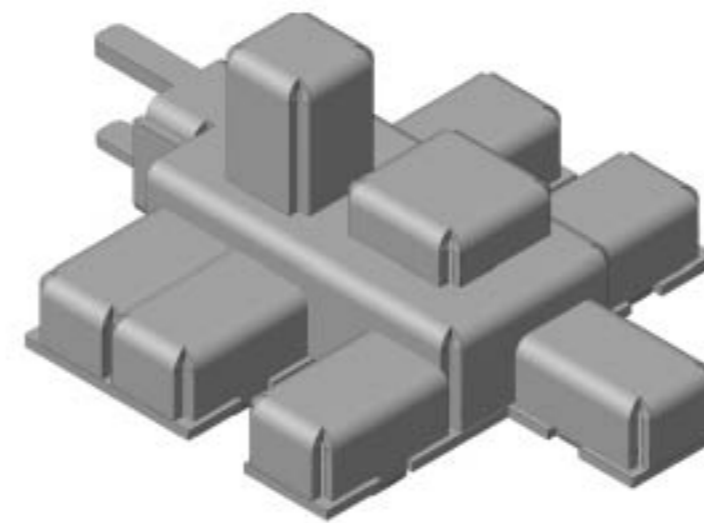
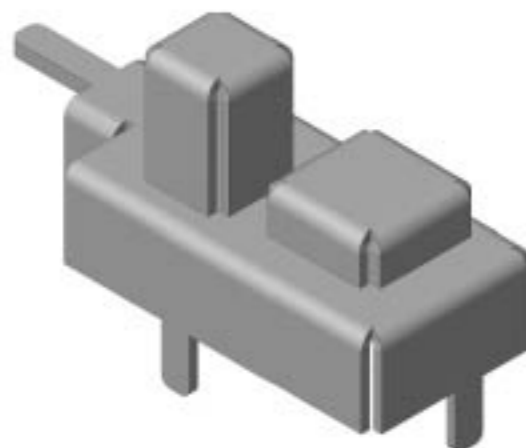
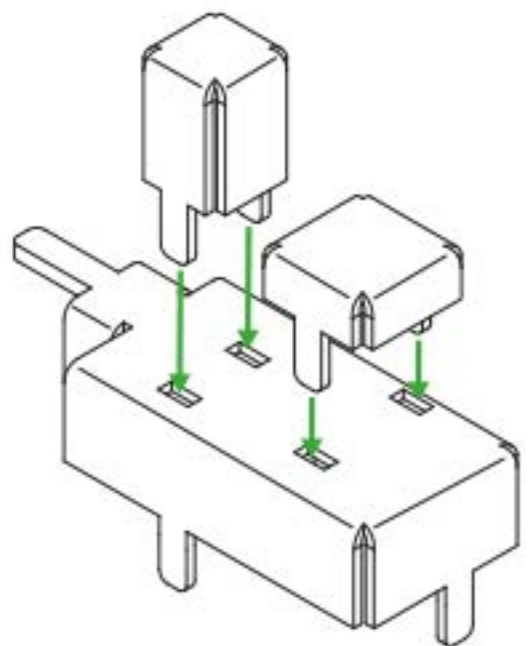
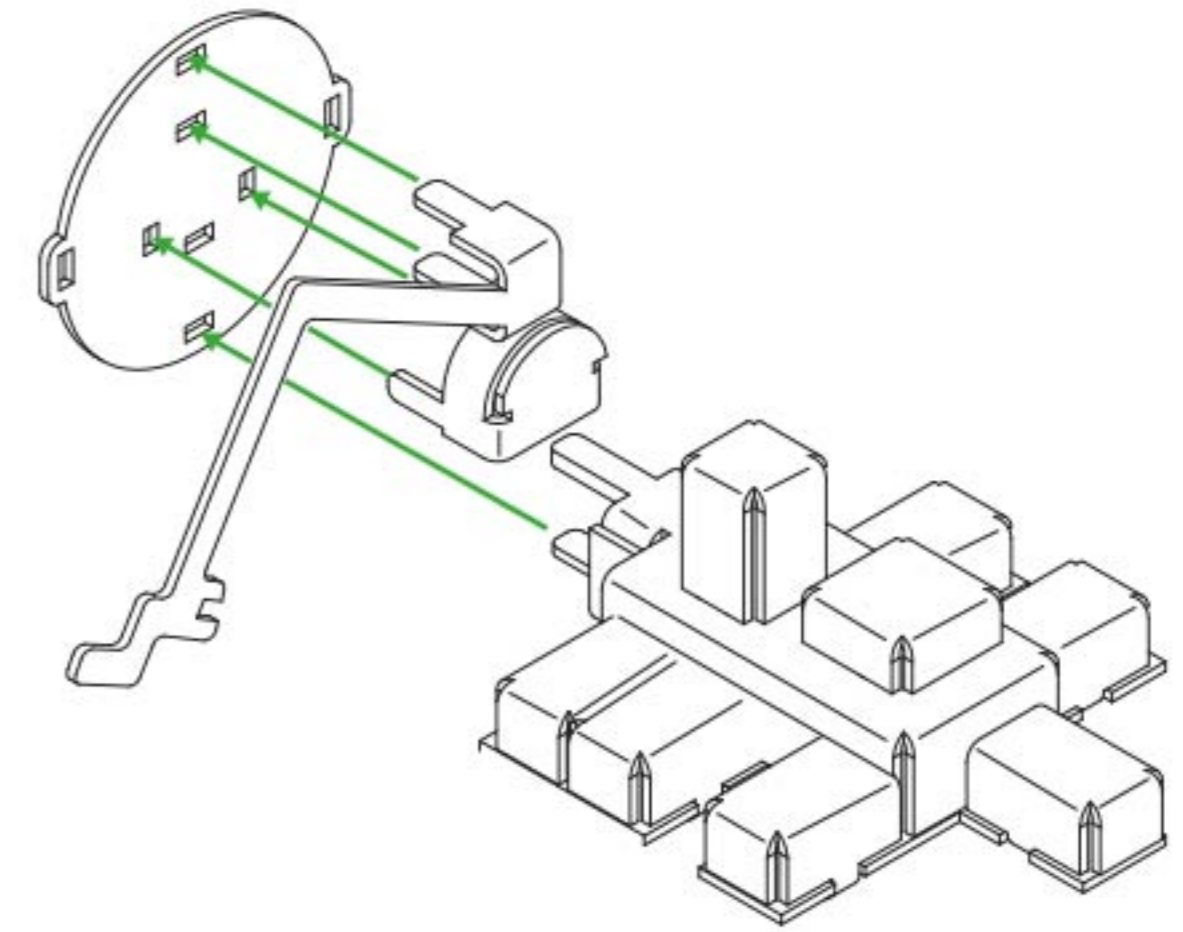
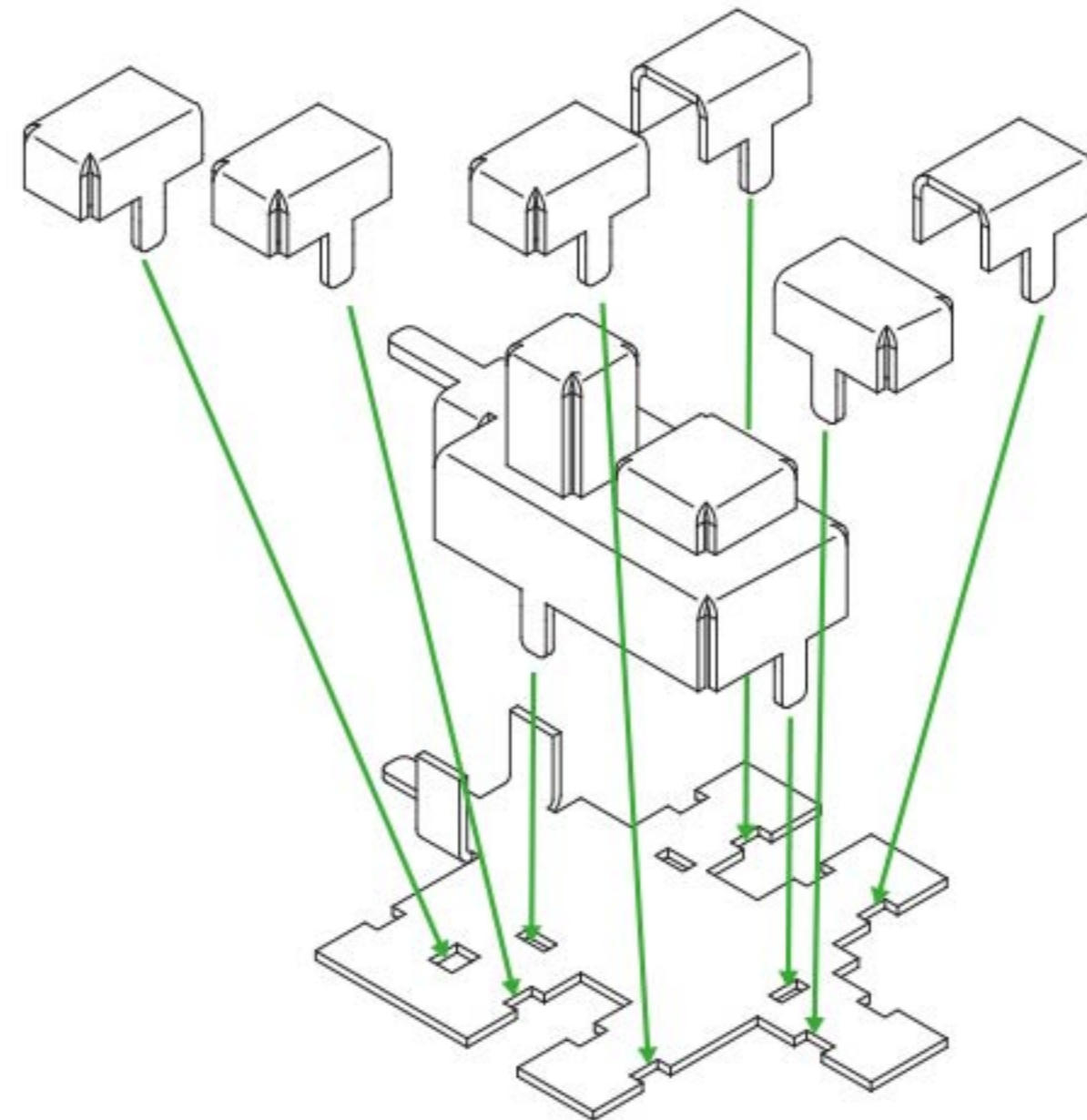
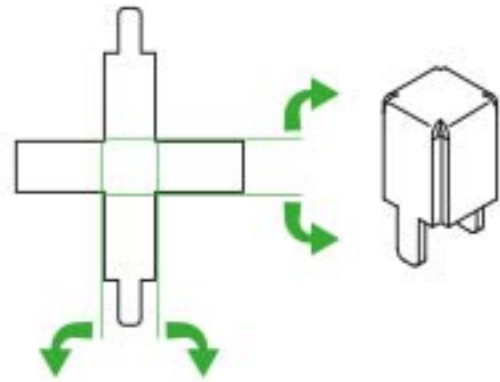
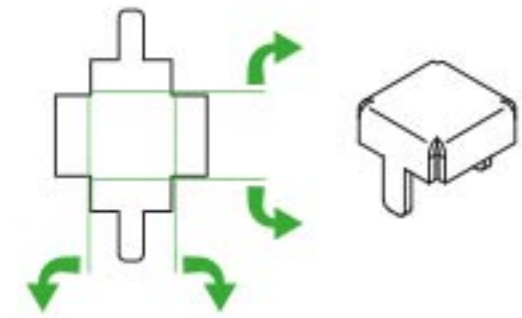

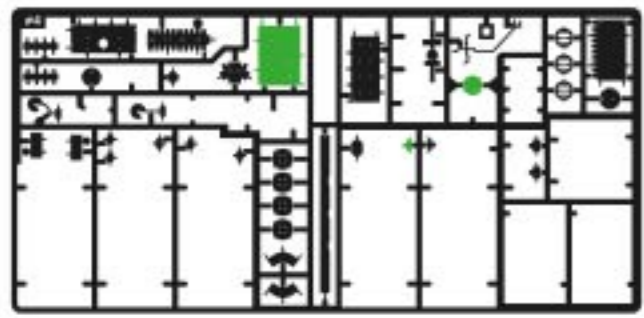

#4

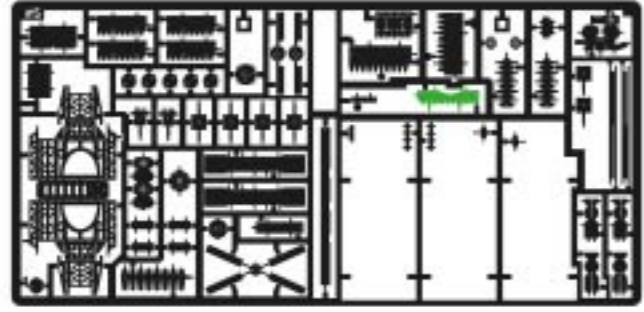

#5

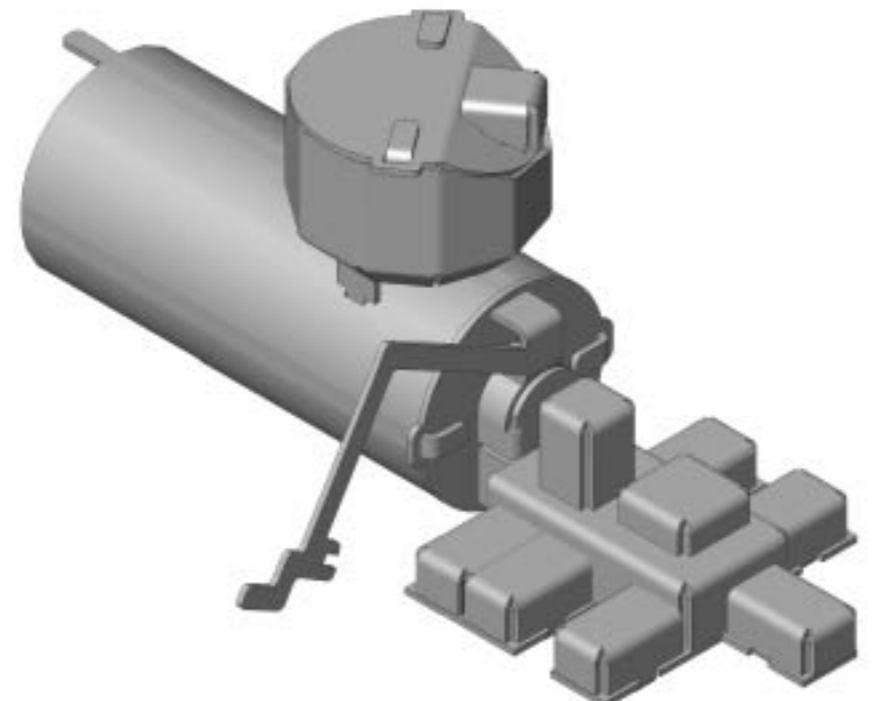
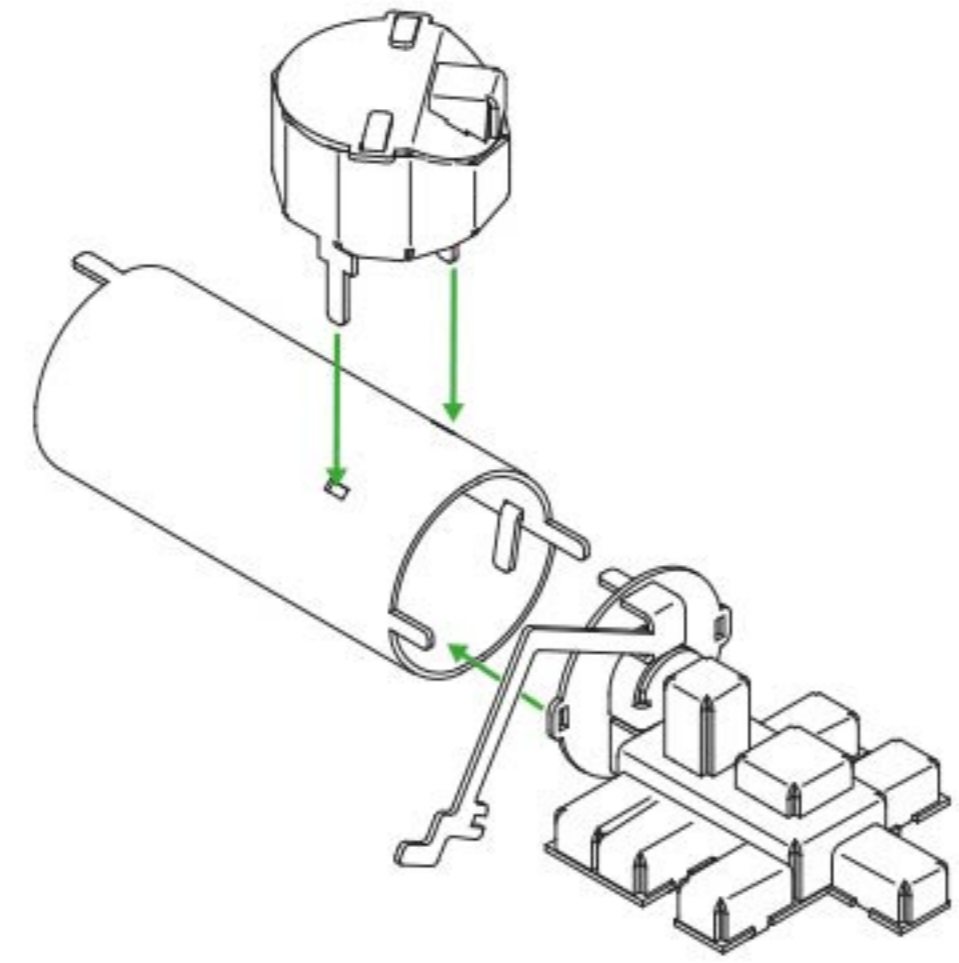
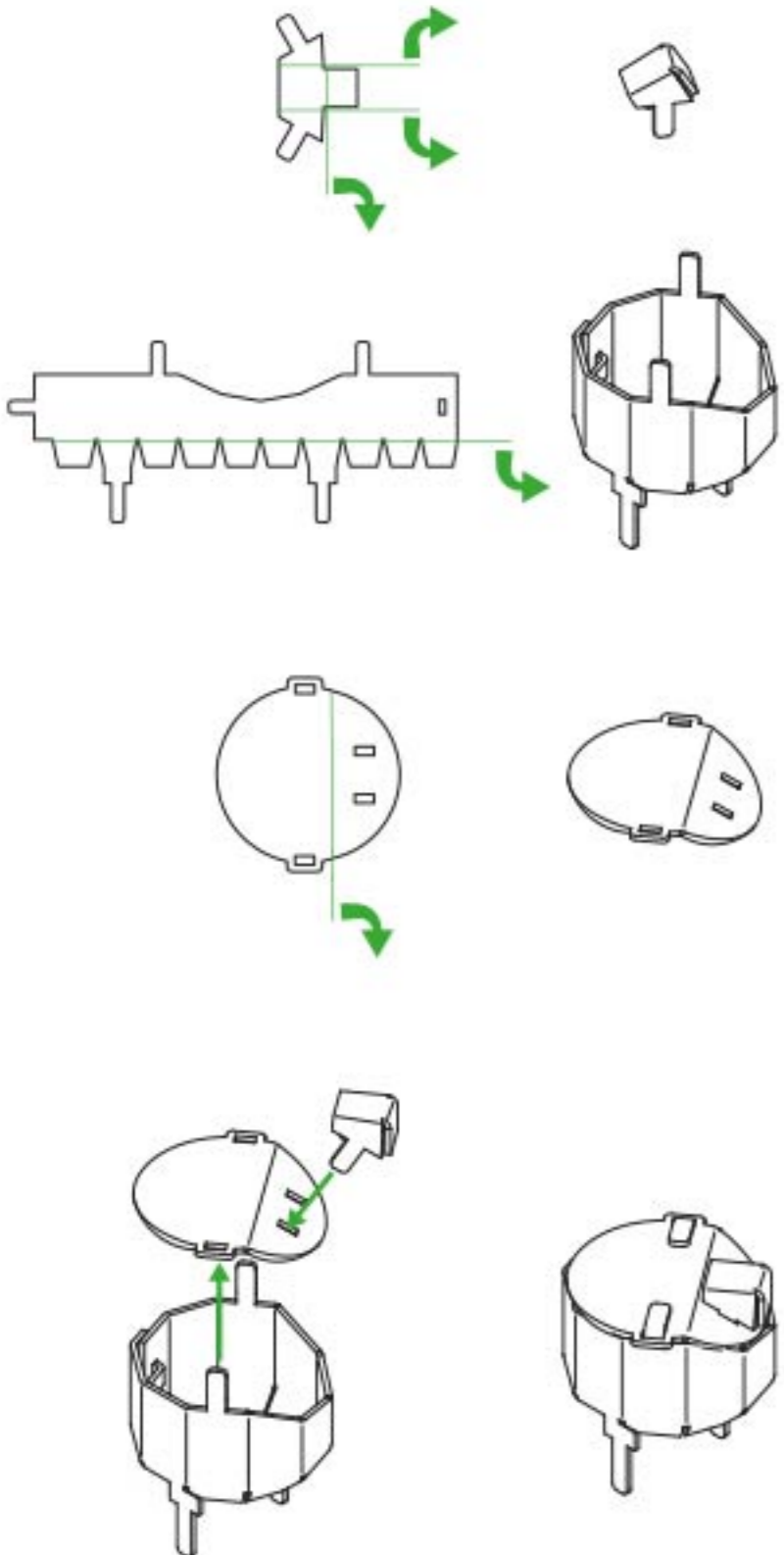
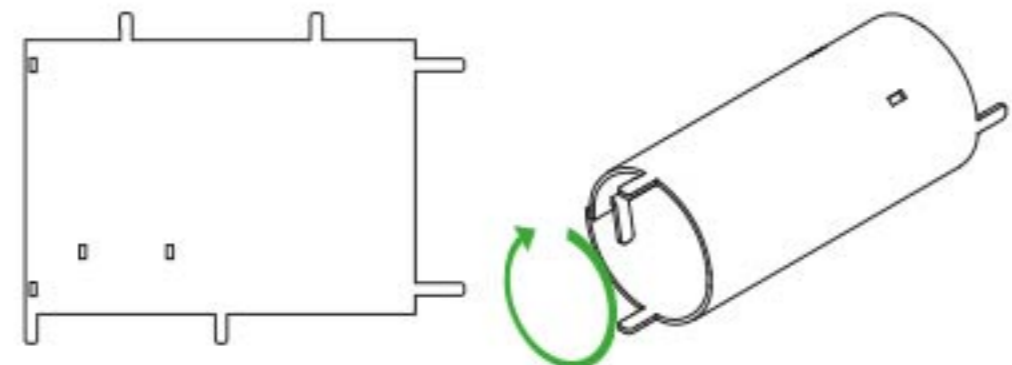

11

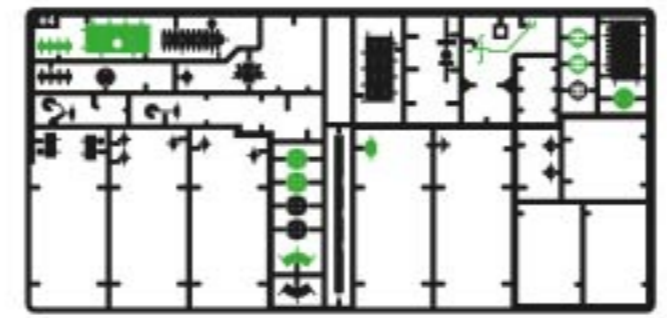

#4

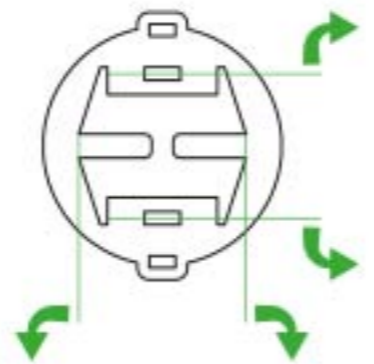
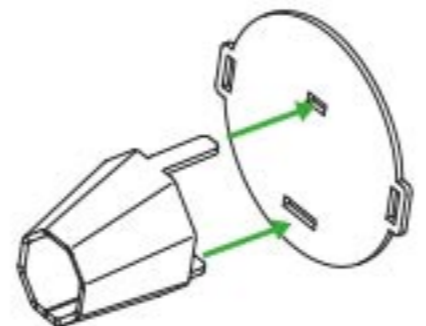
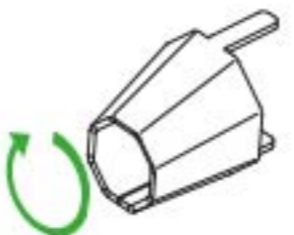
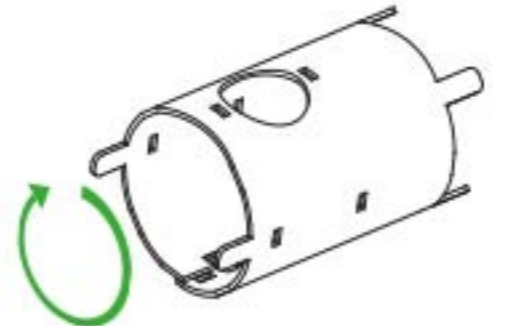
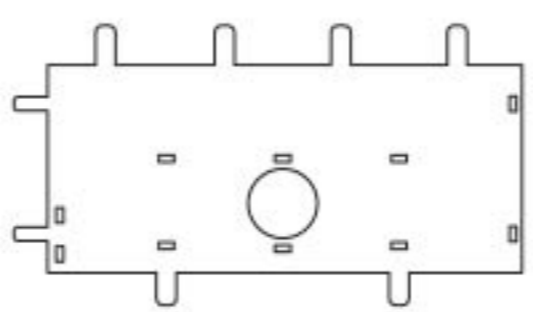
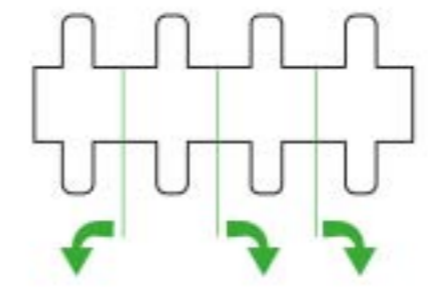

x2

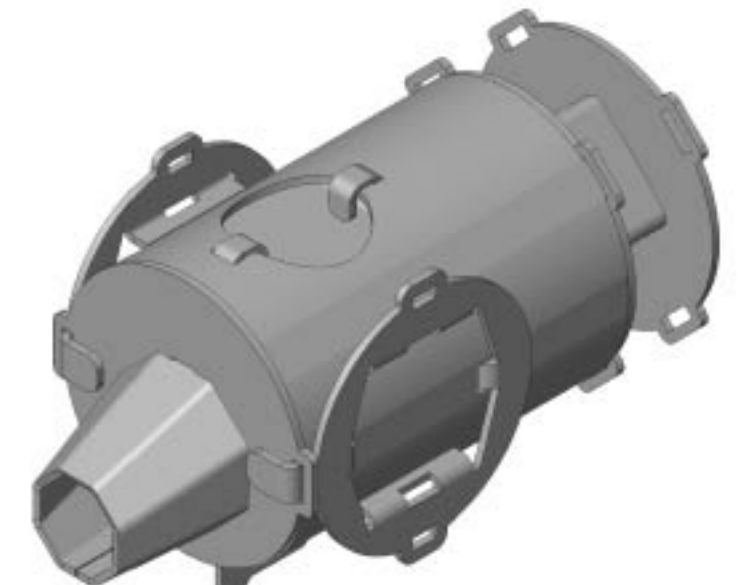
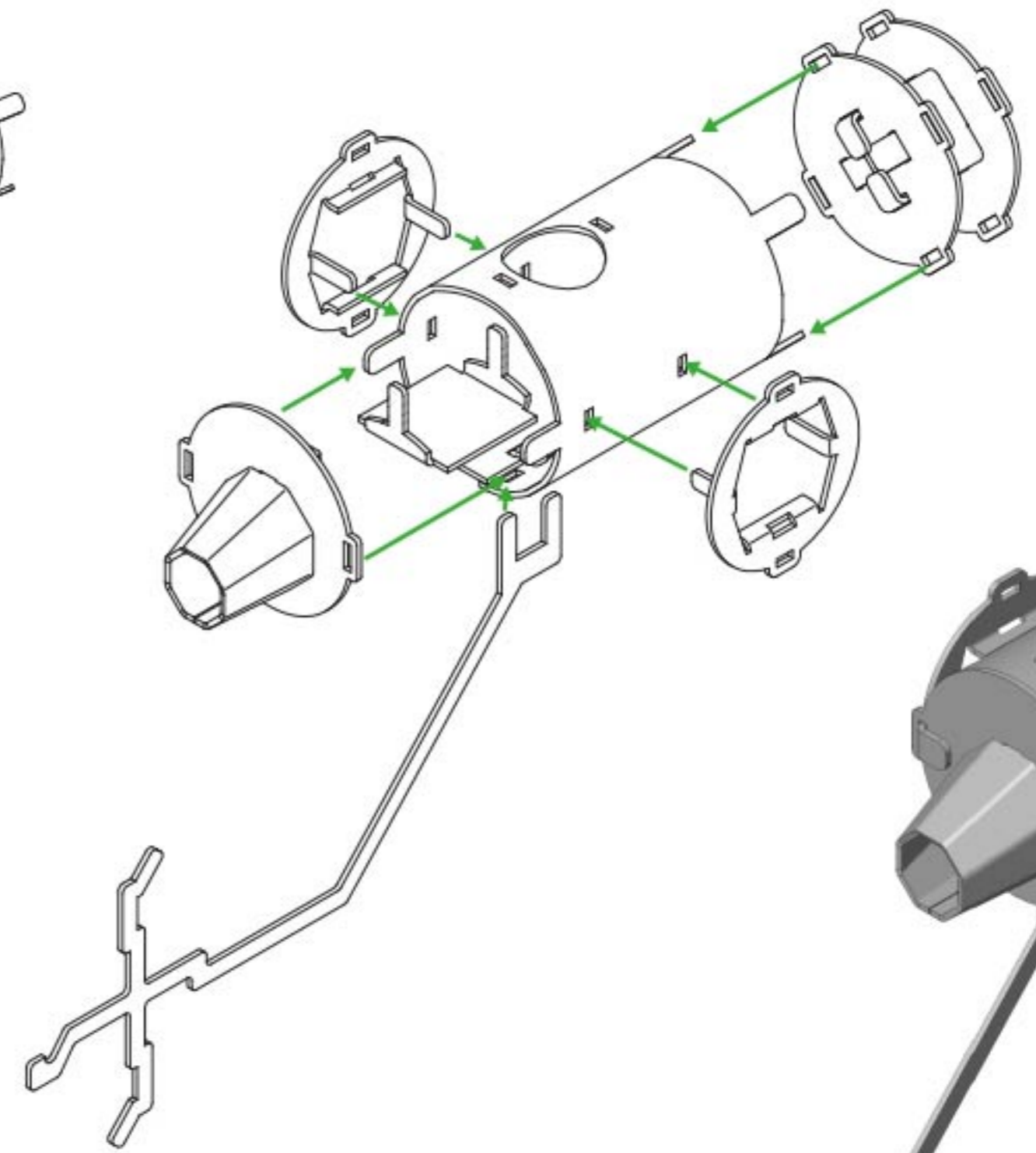
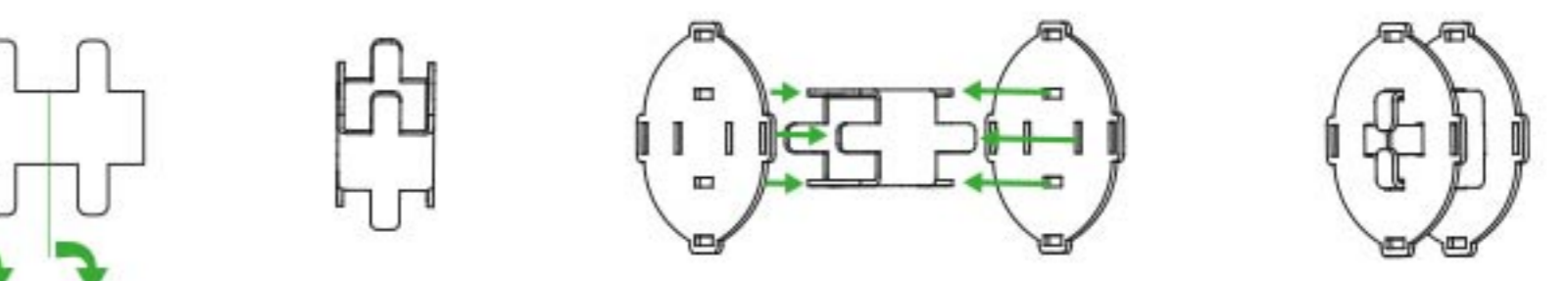
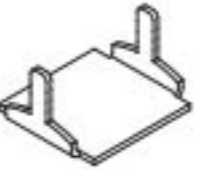
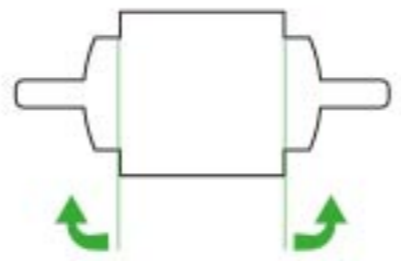

12

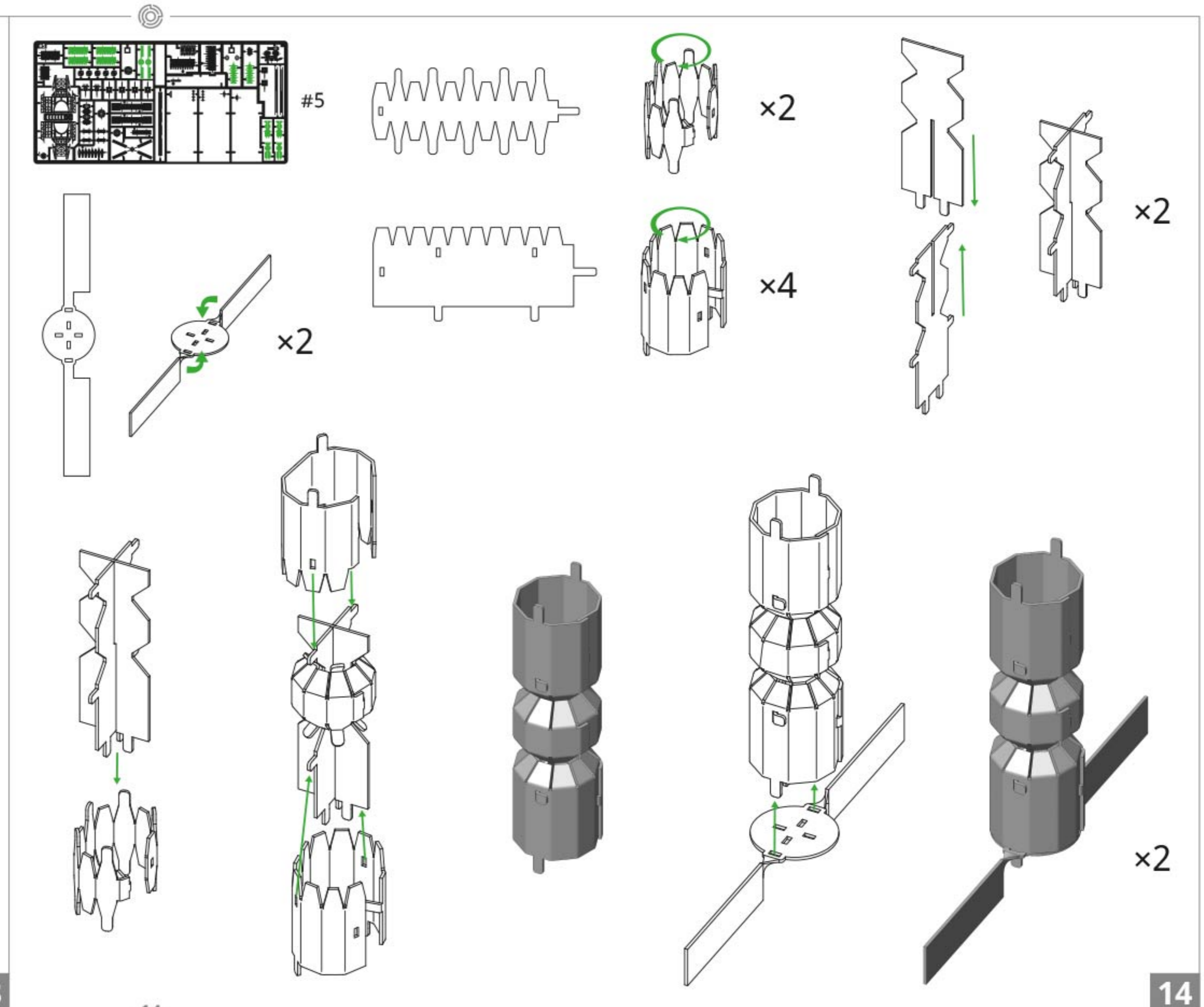
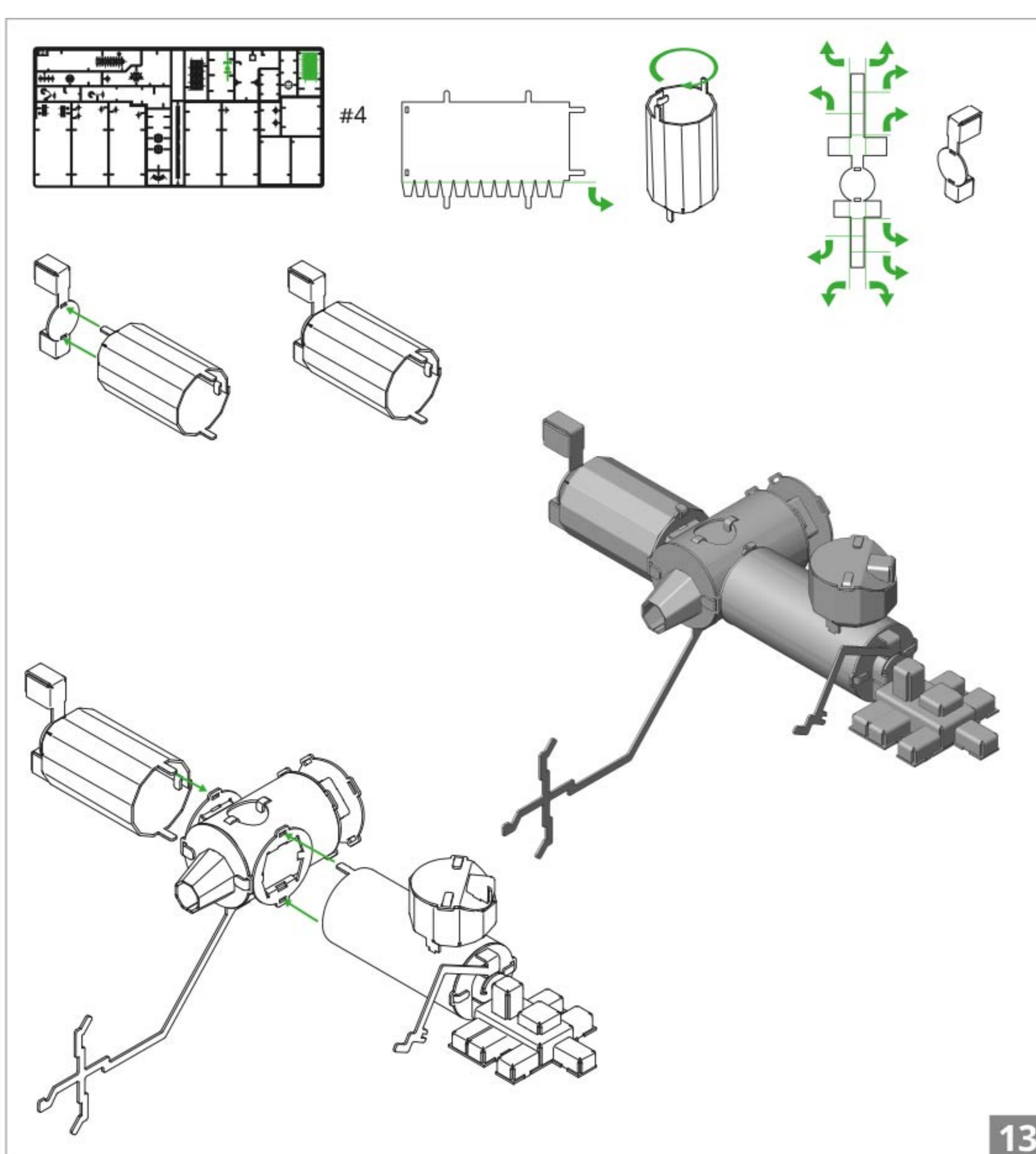

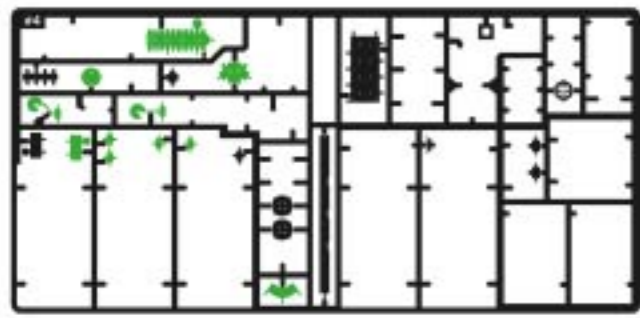

#4

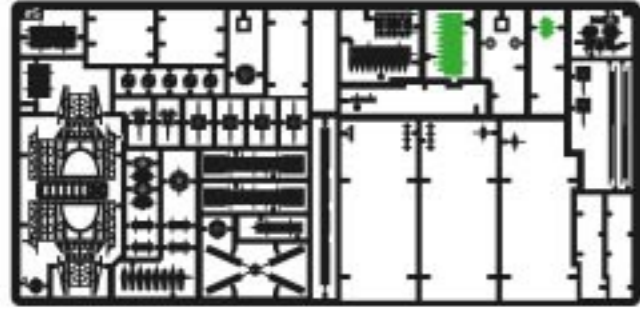

#5

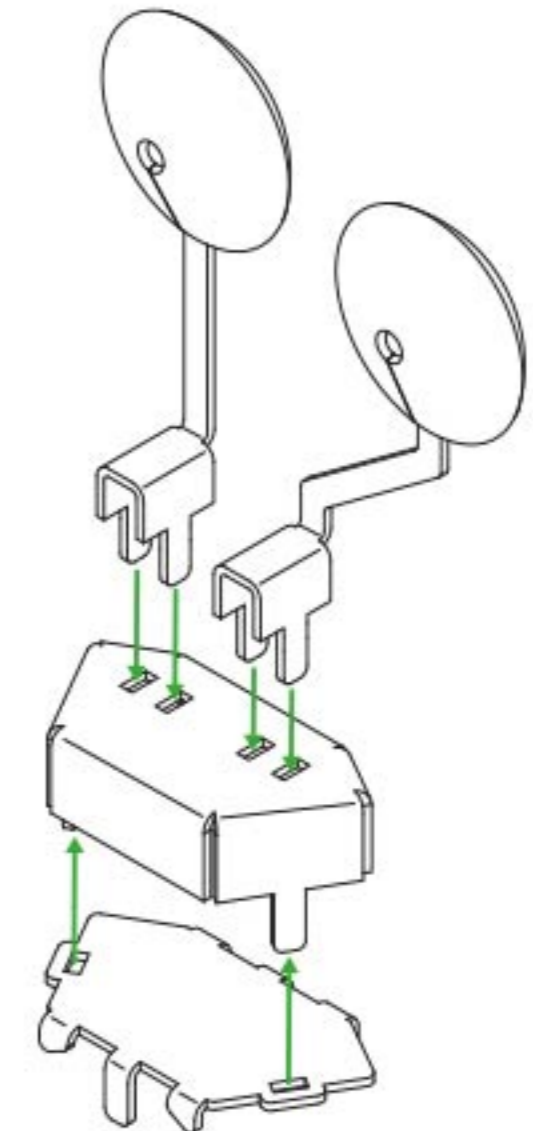
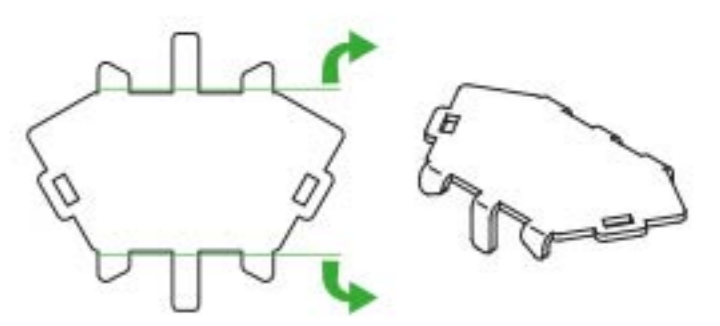
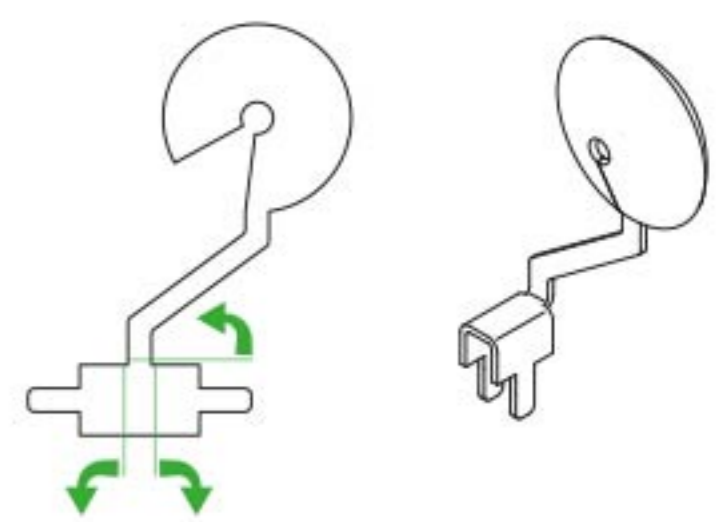
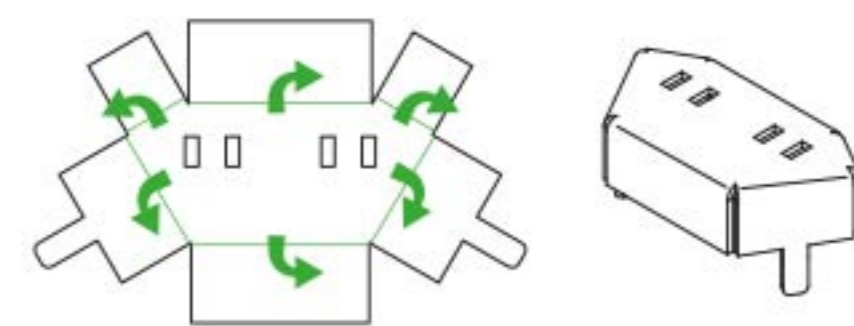
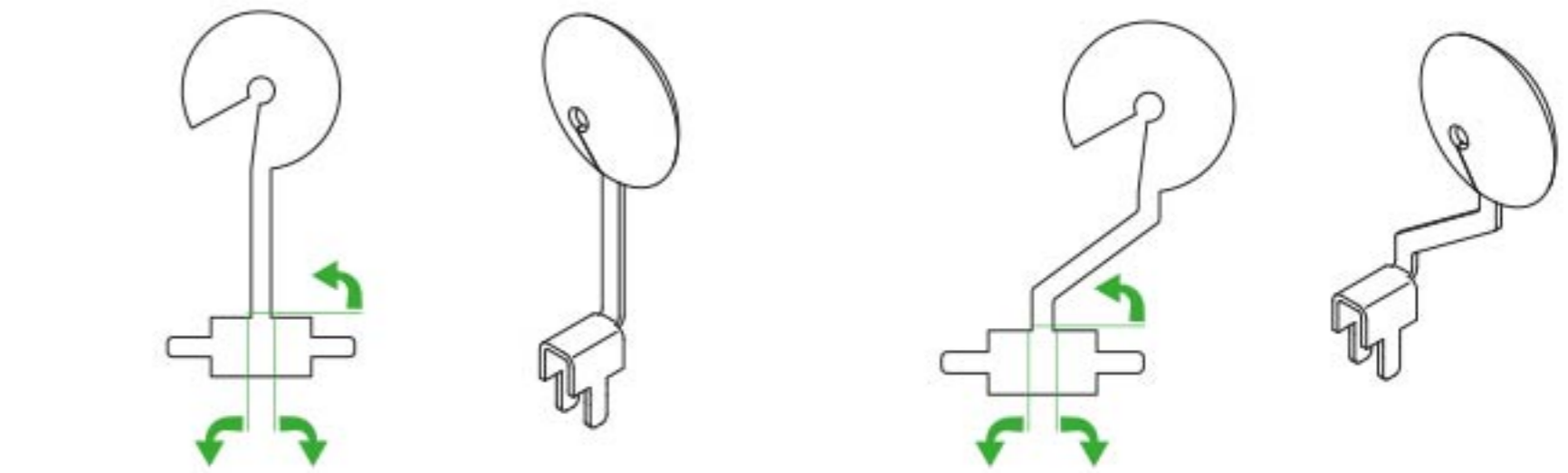
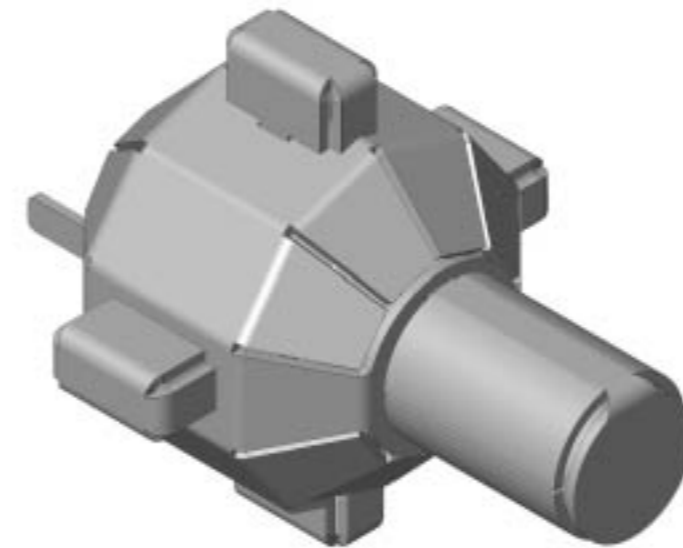
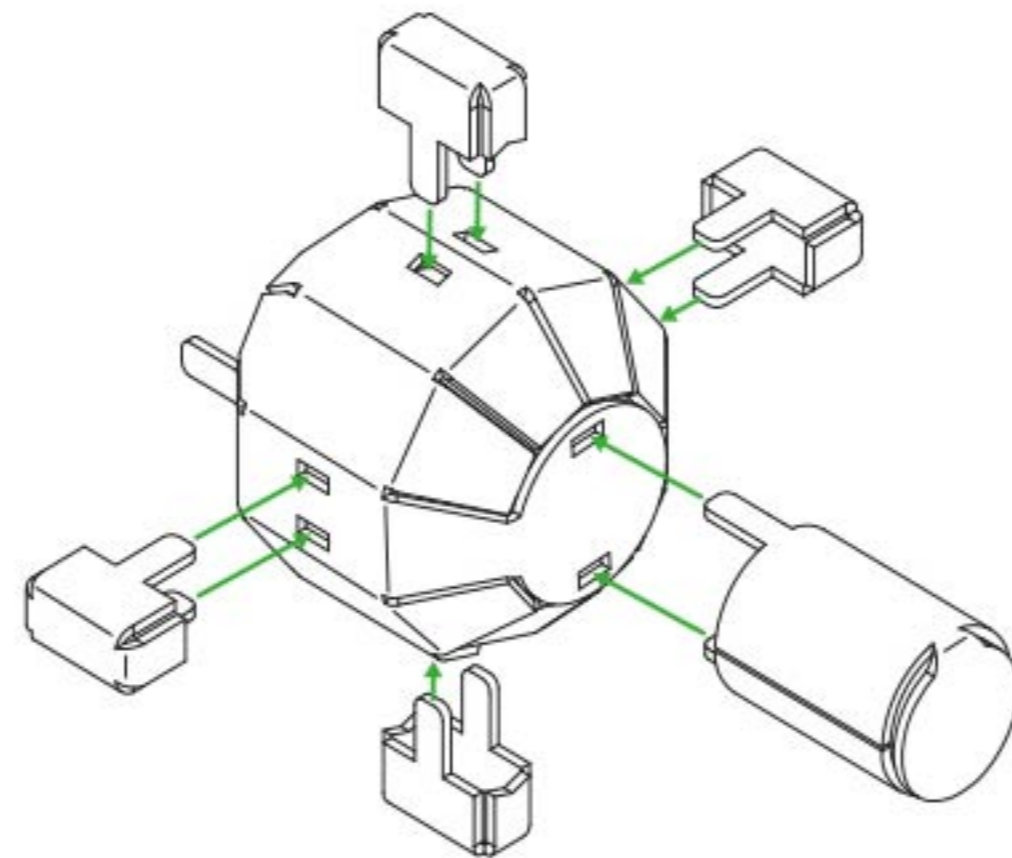
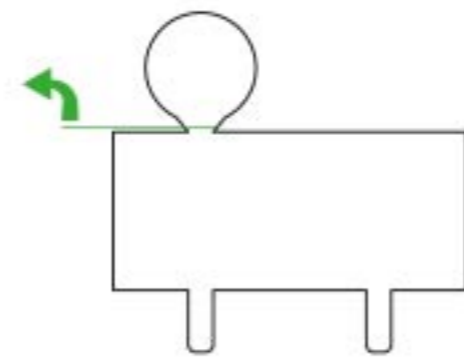
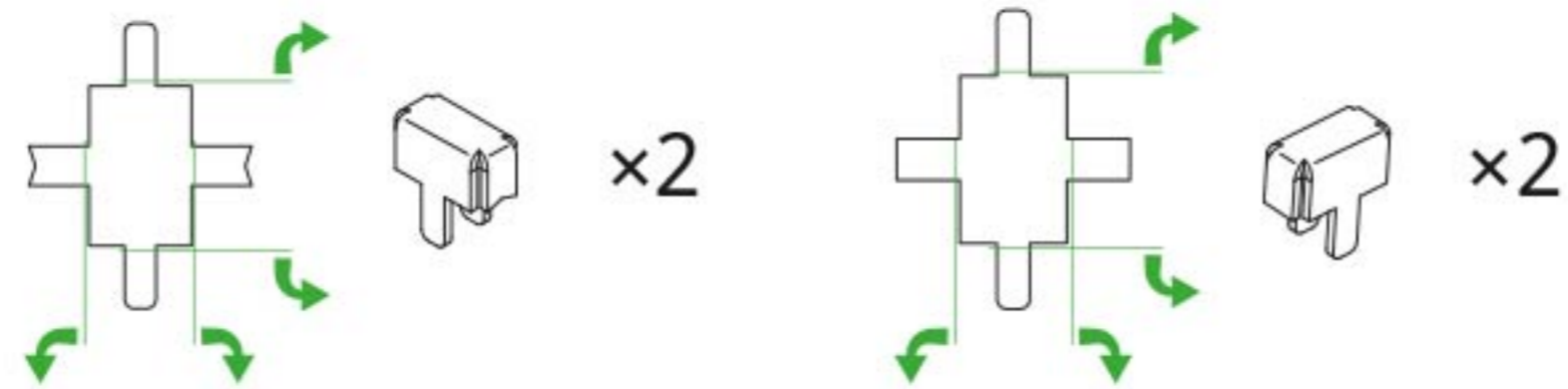
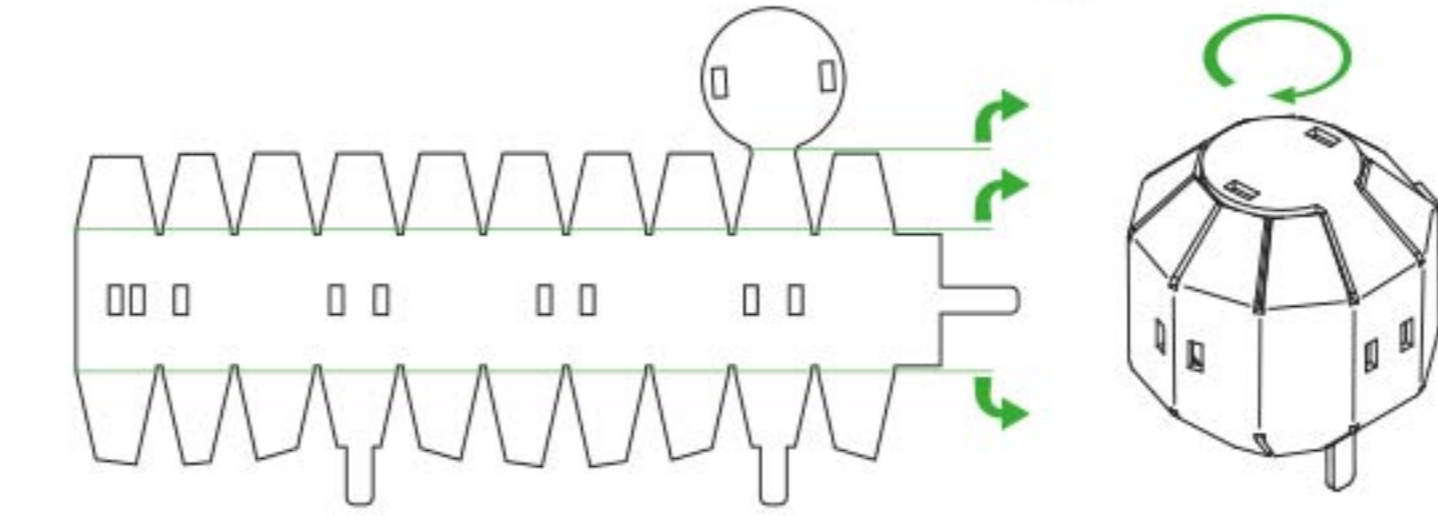
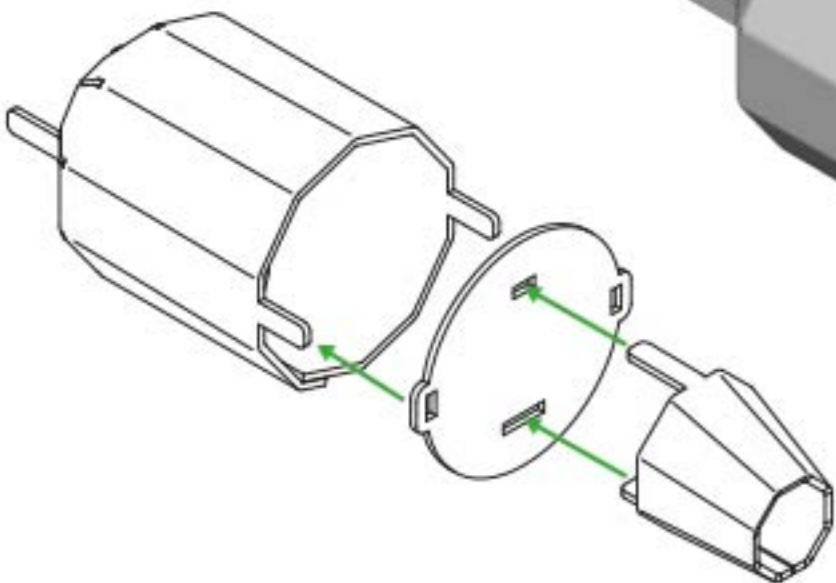
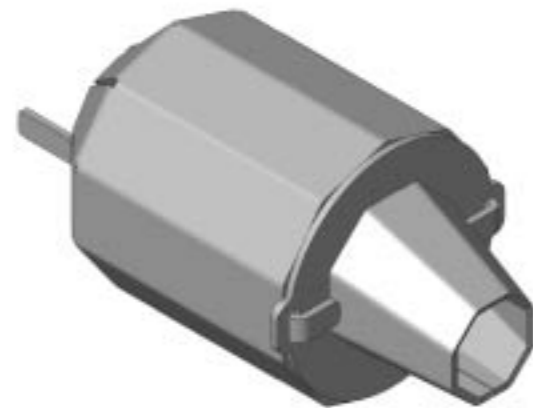
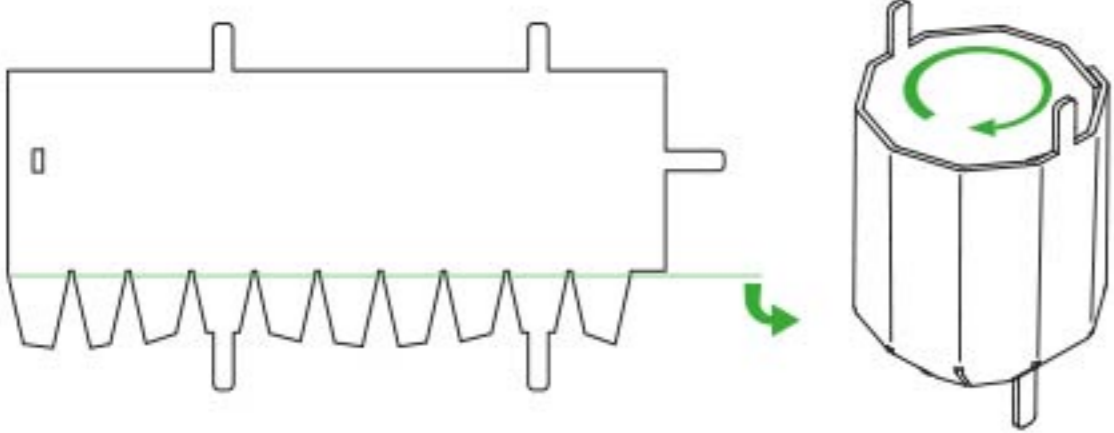

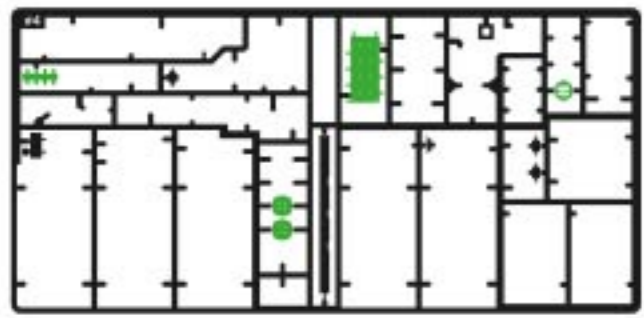

#4

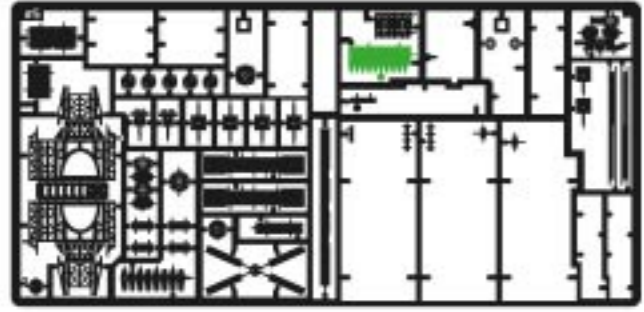

#5

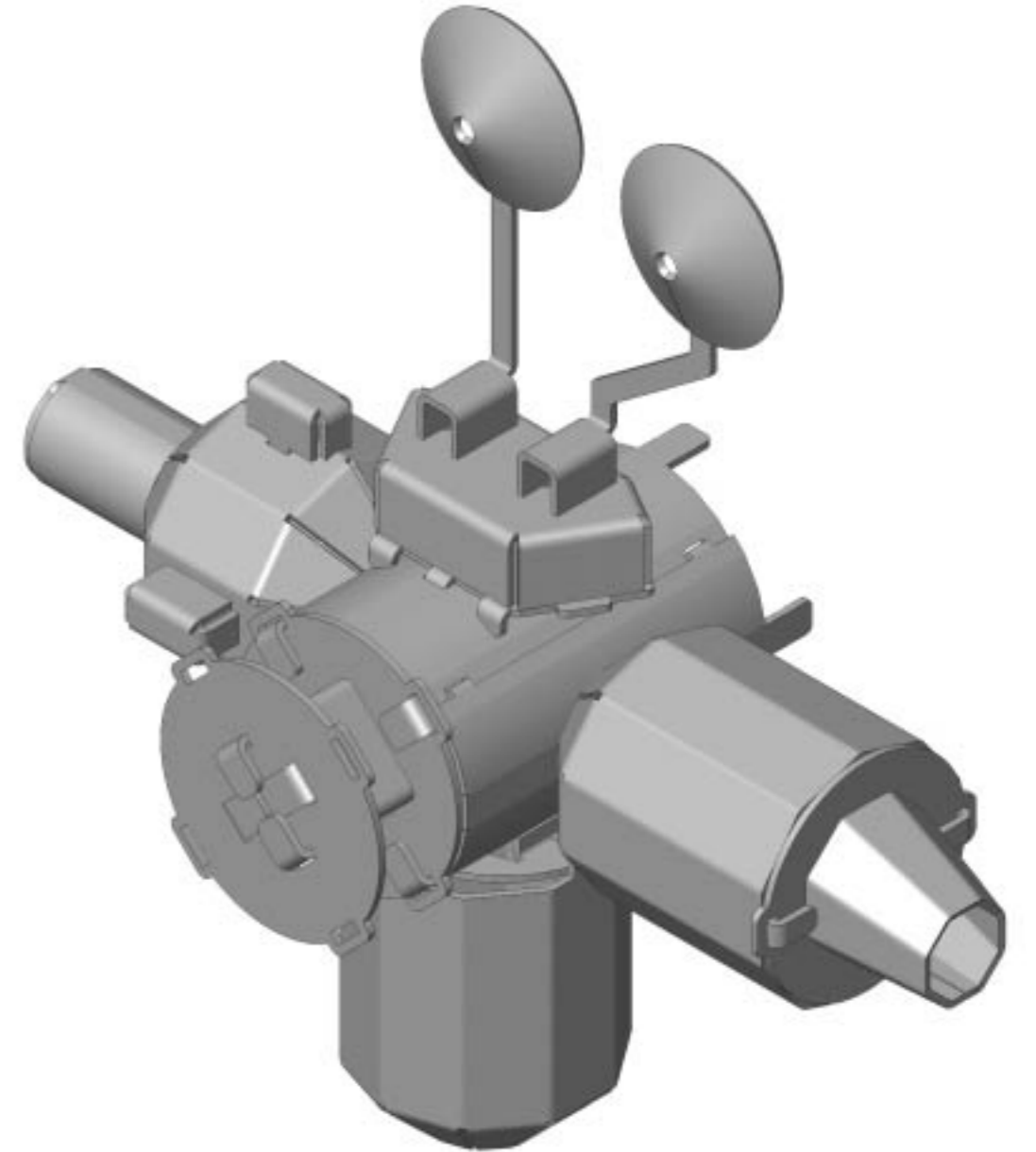
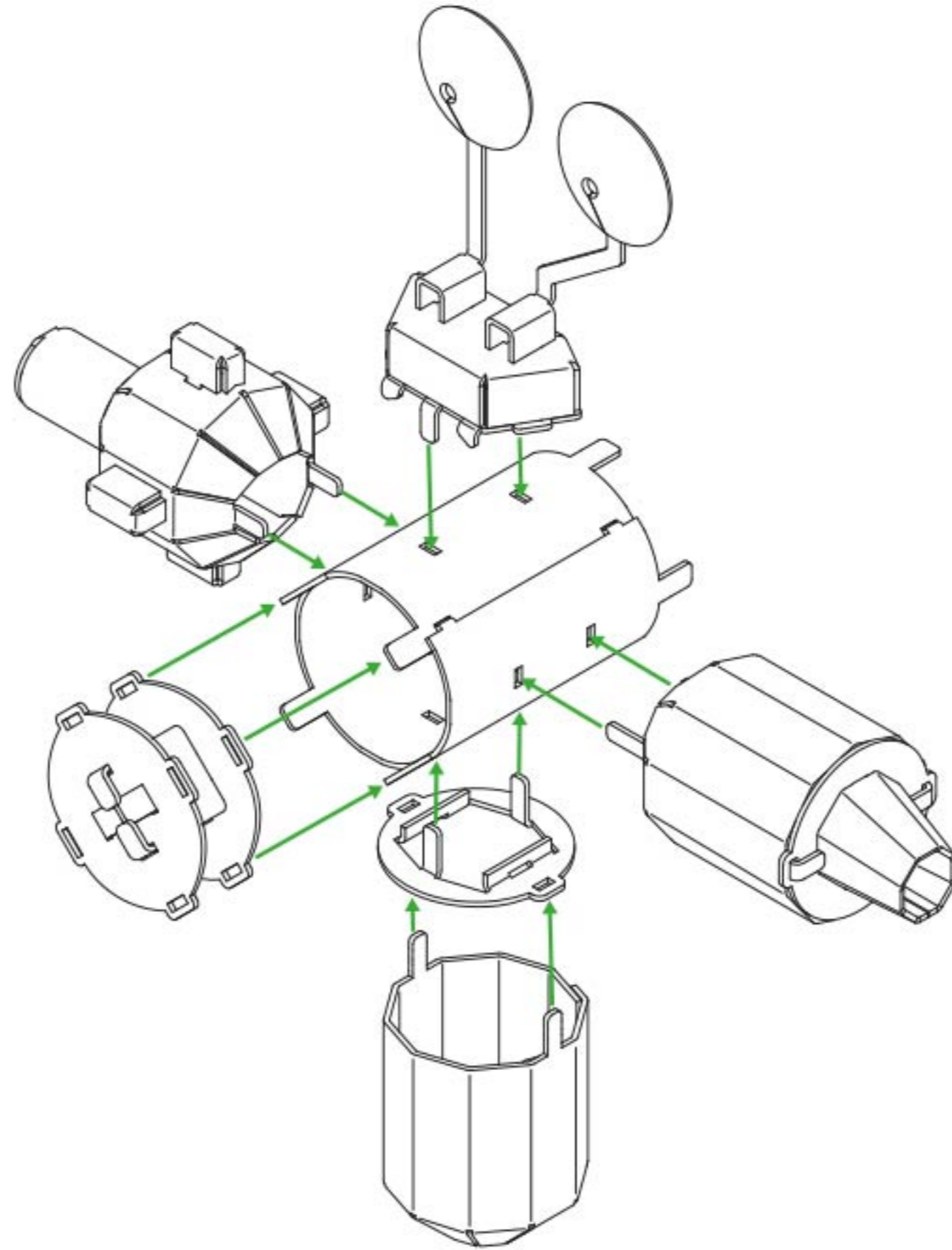
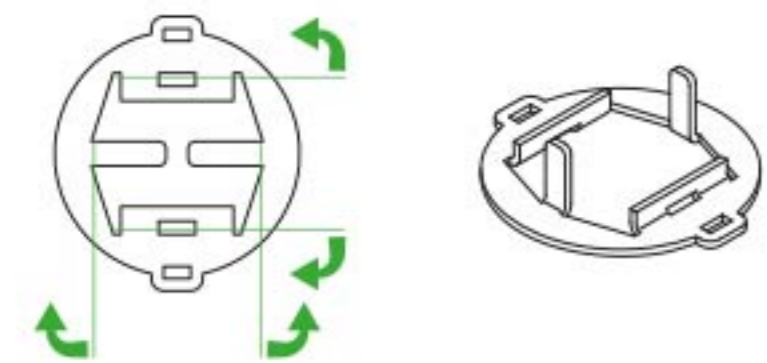
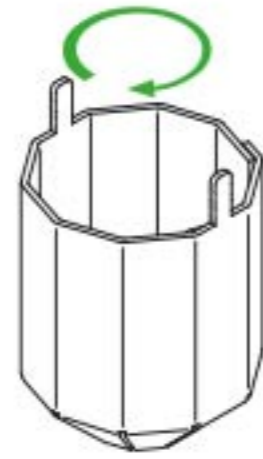
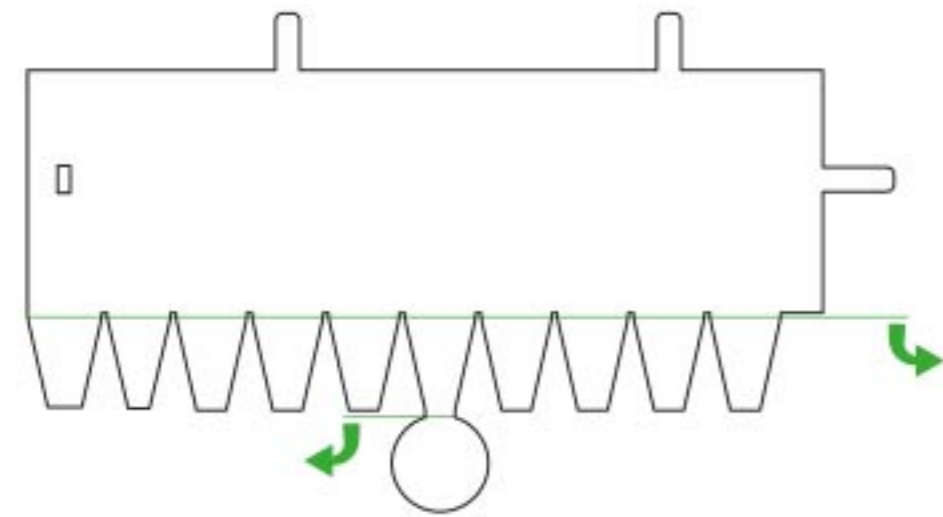
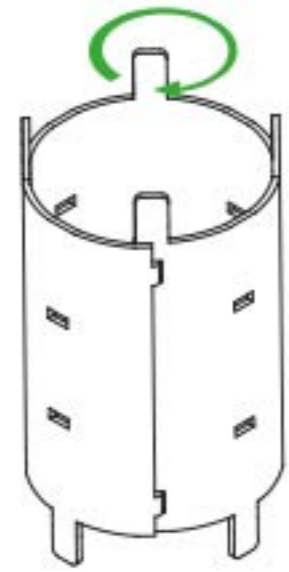
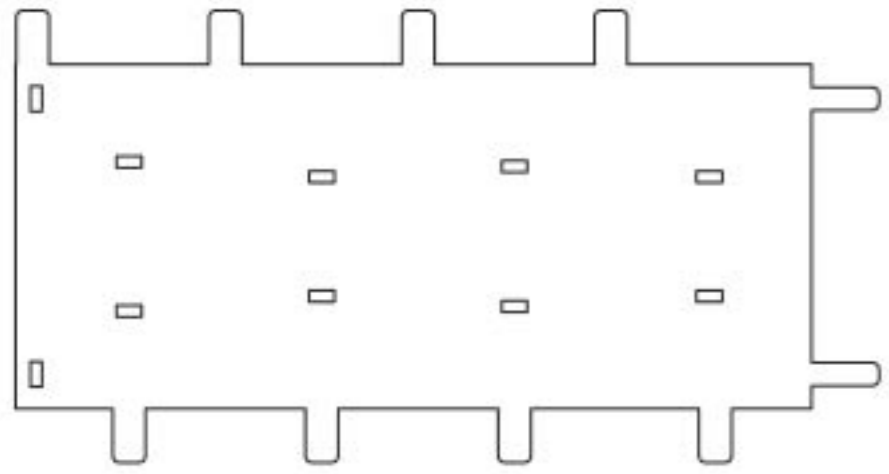
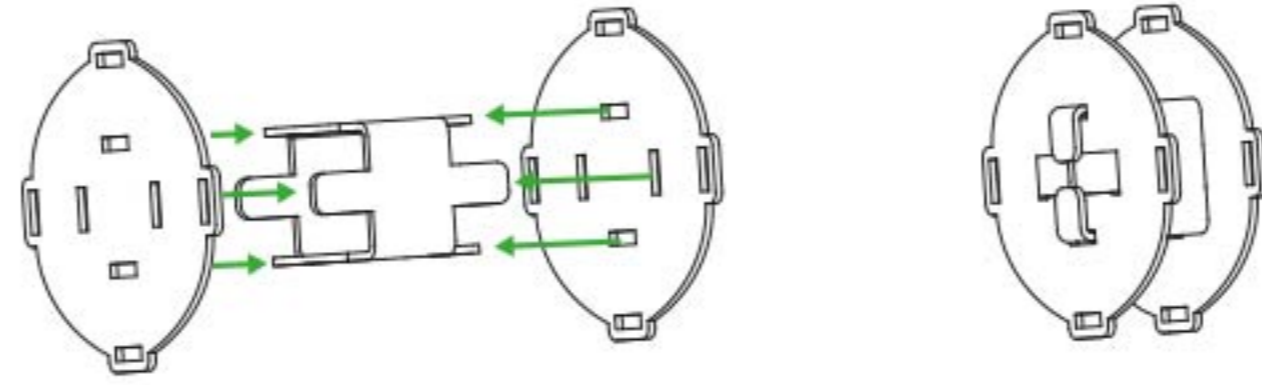
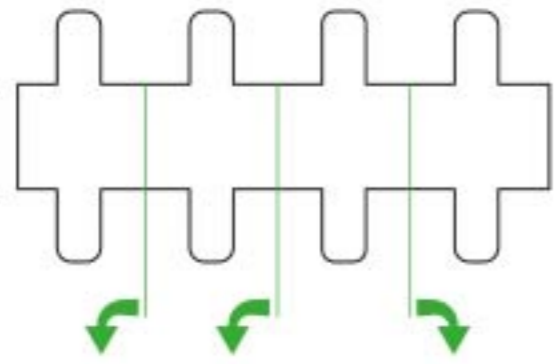



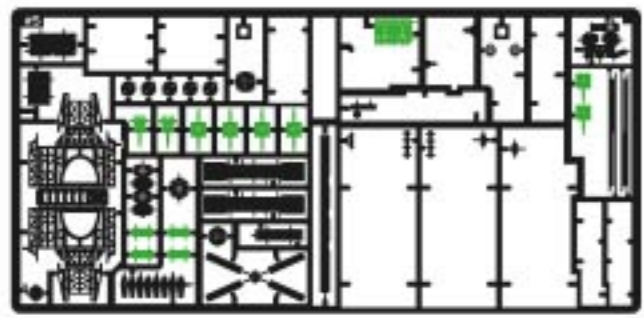

#5

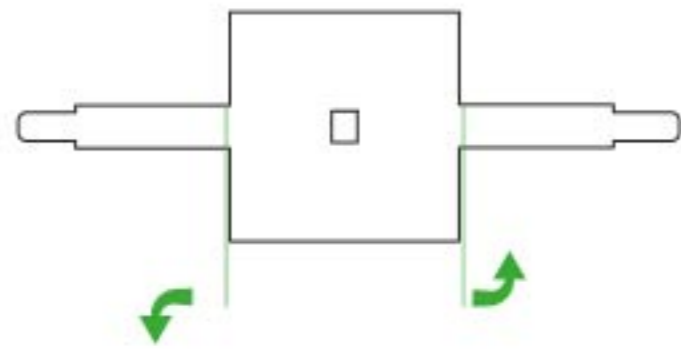

x4

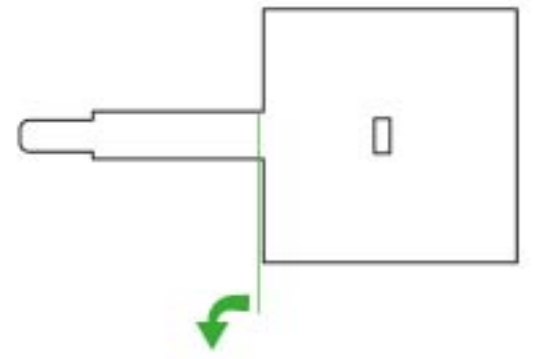

x2

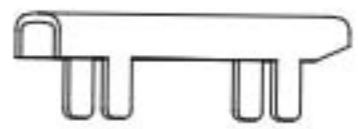
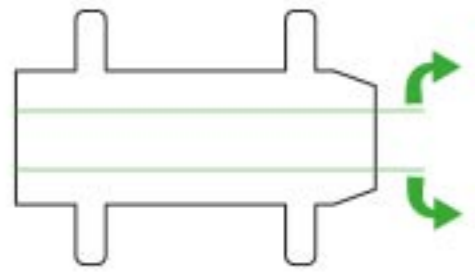

x4

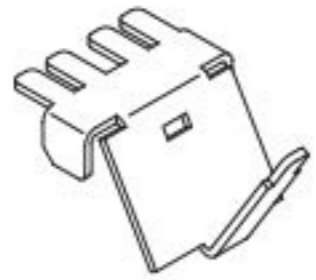
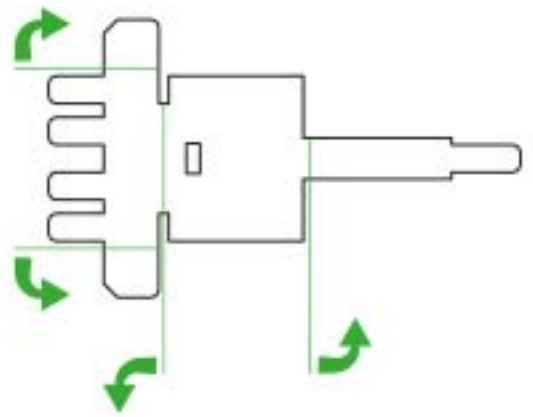

x2

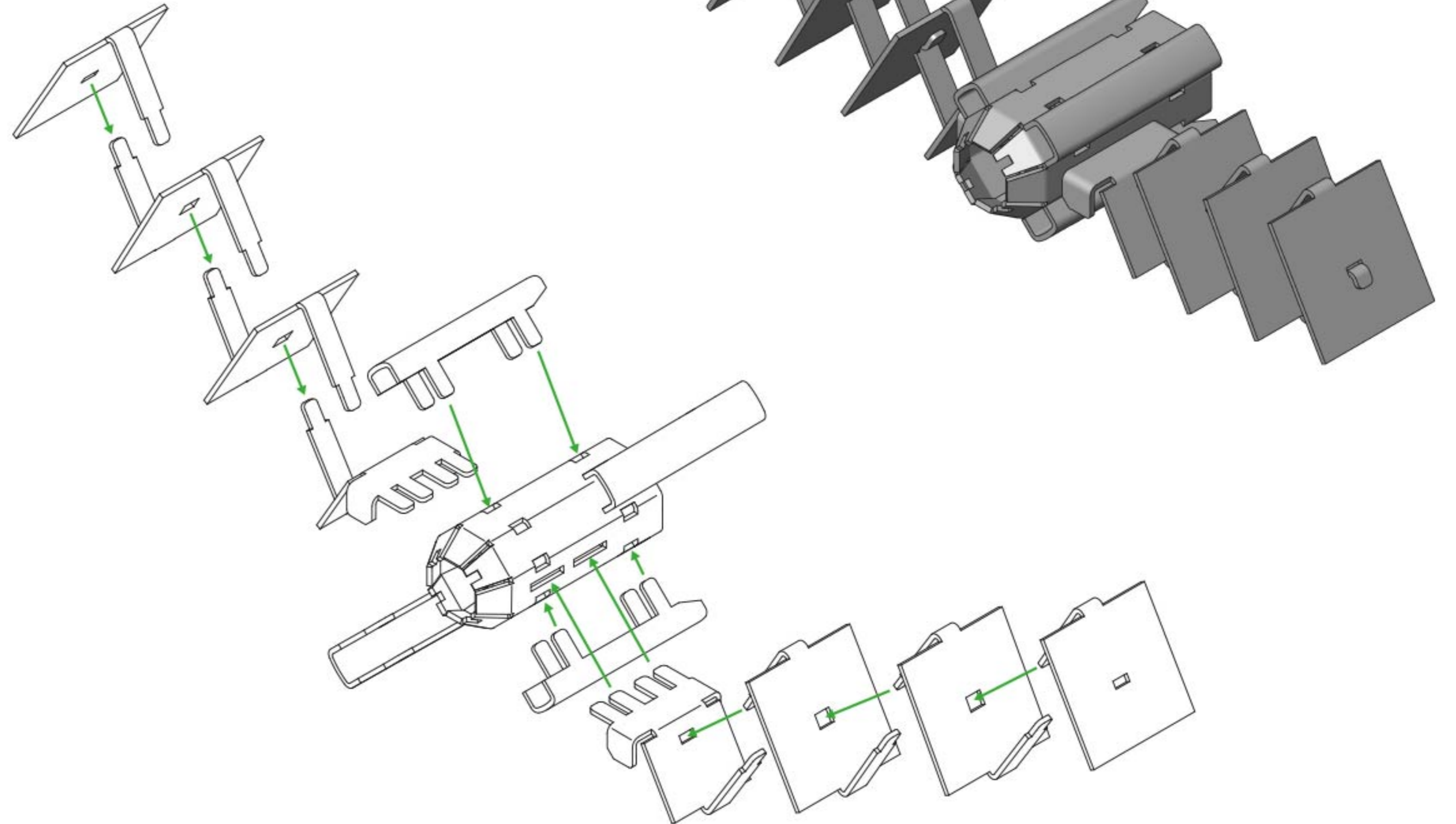
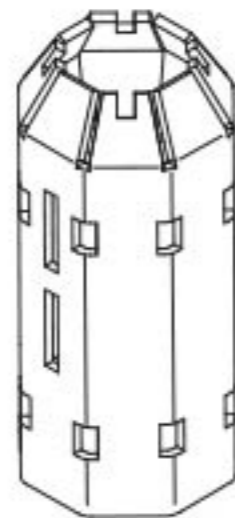
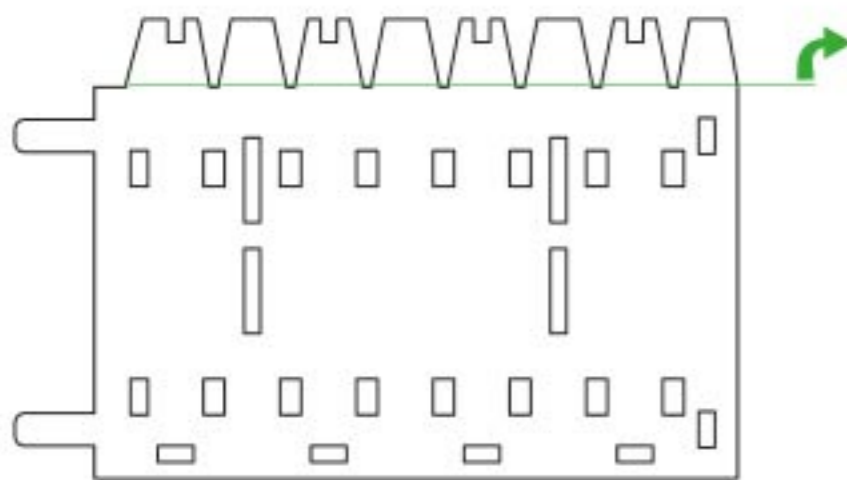

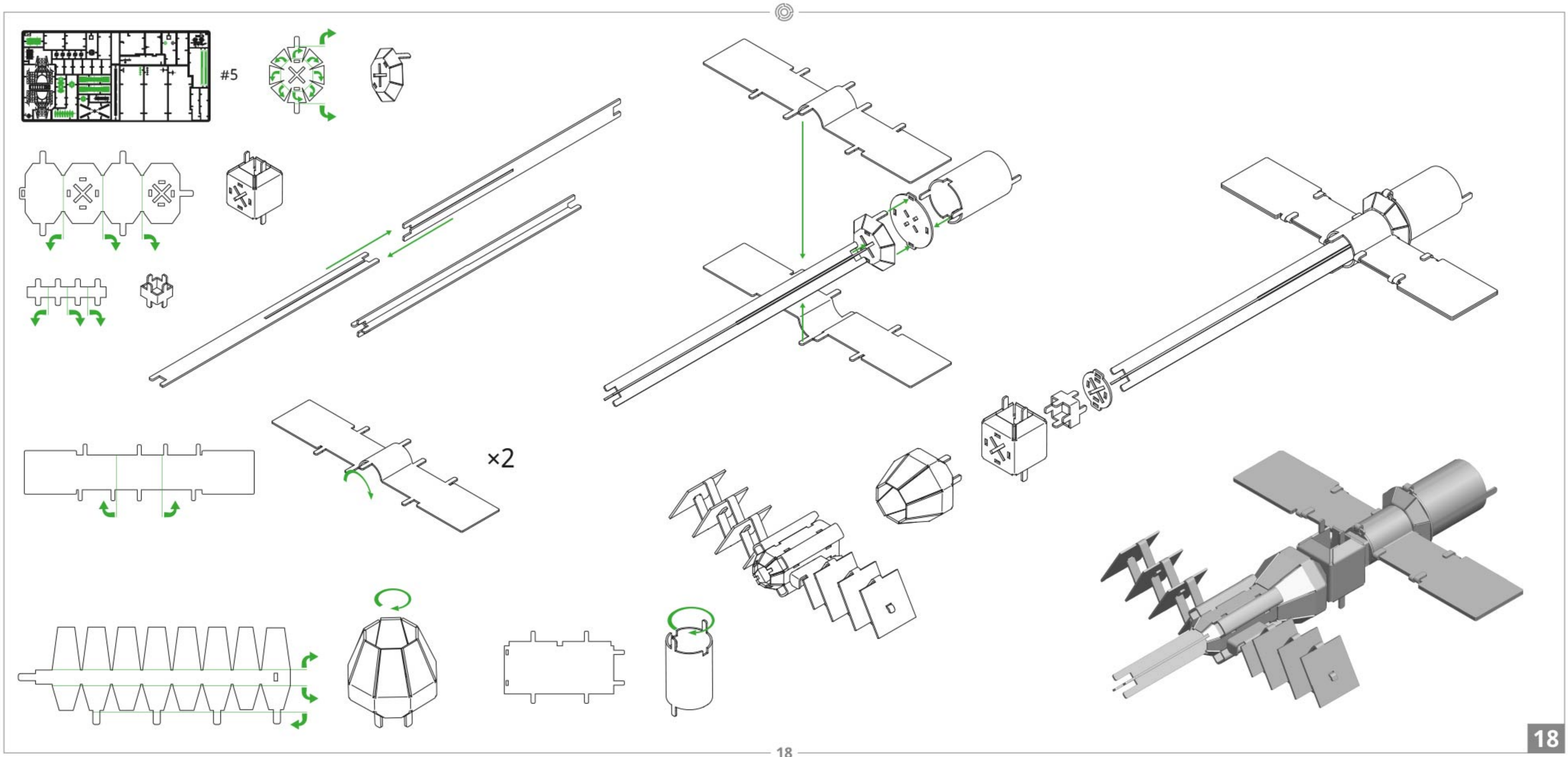



#5

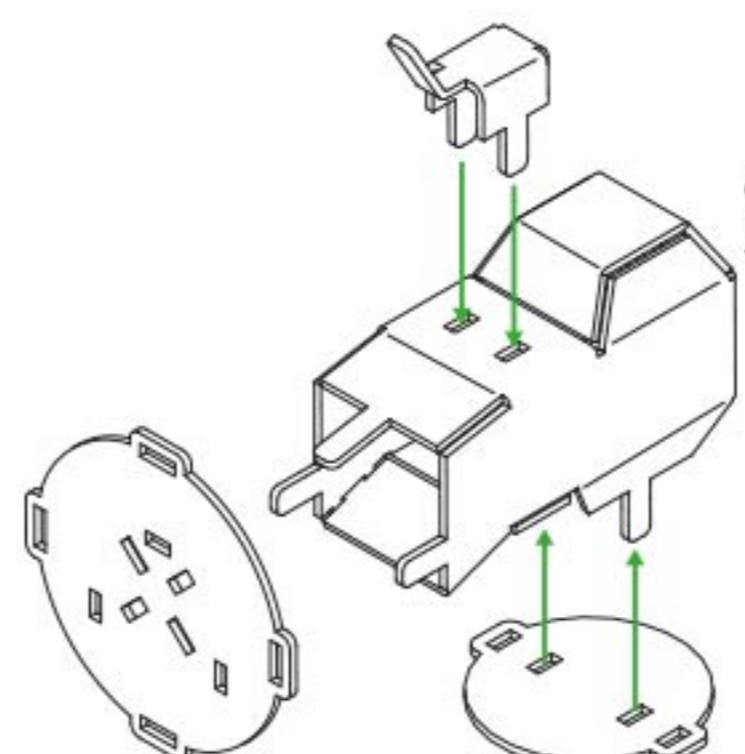
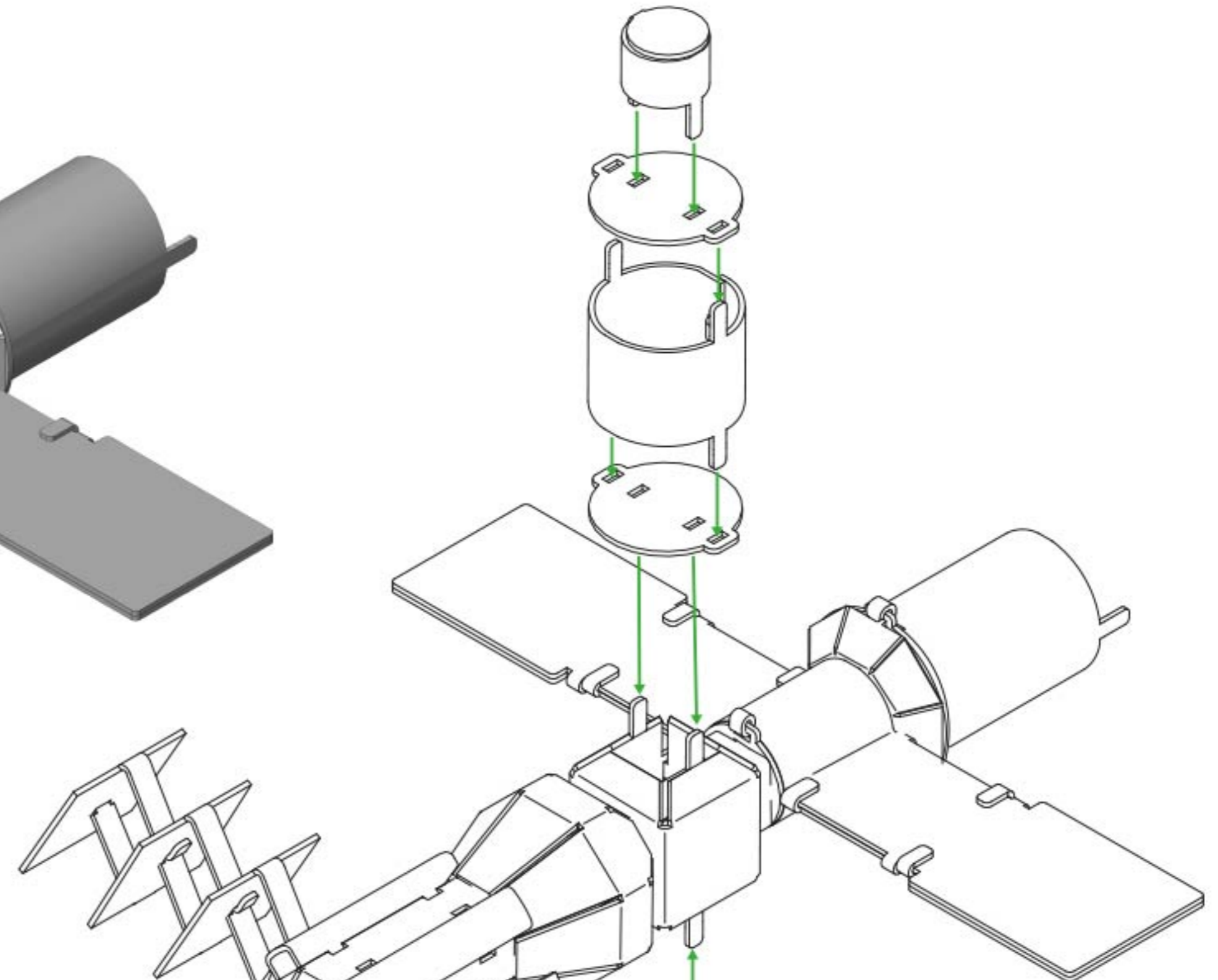
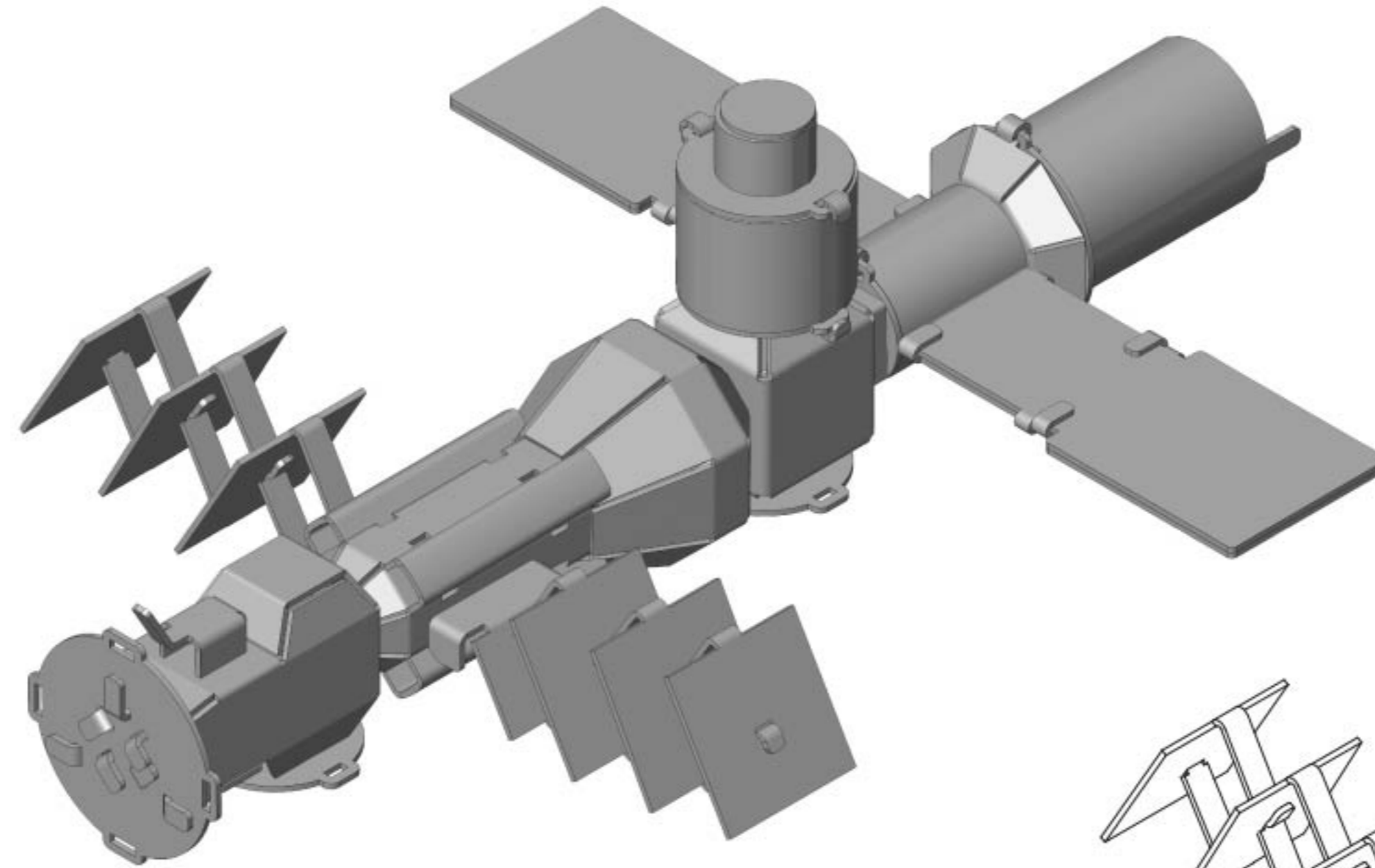
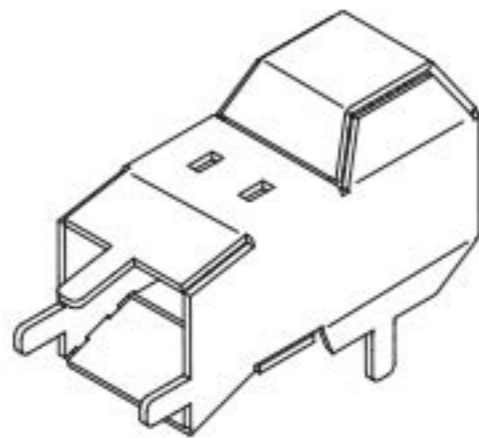
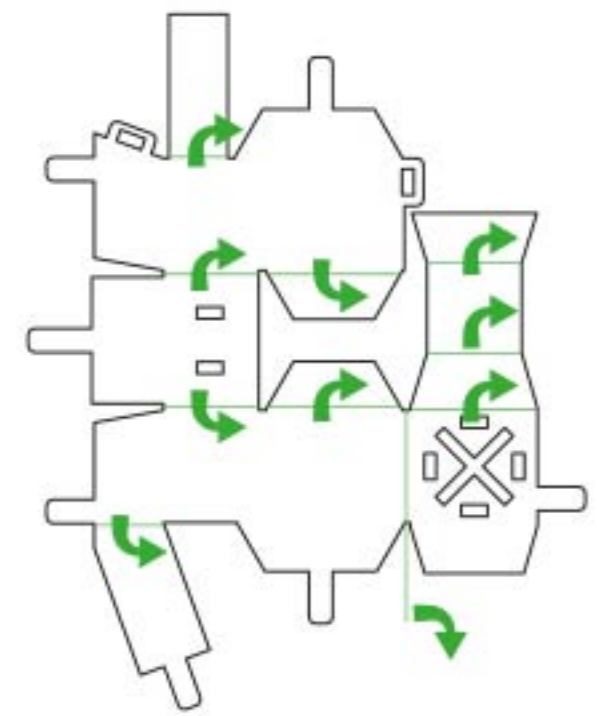
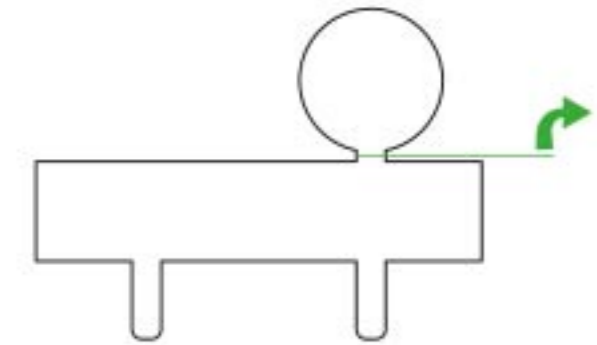
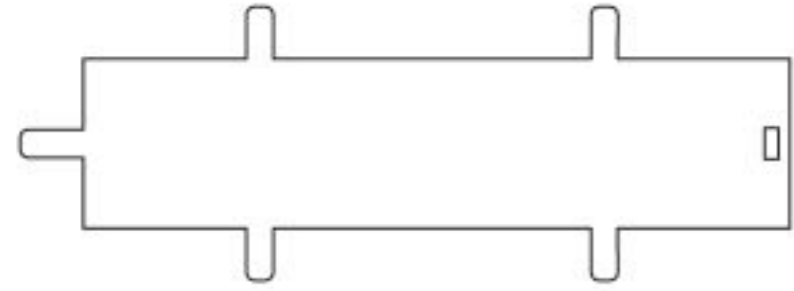
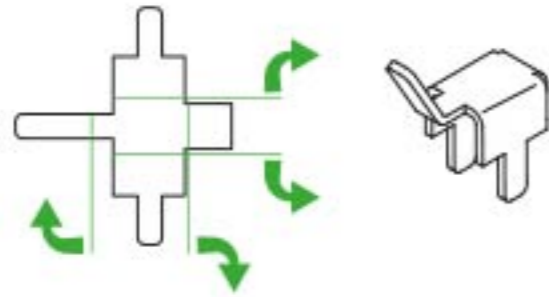

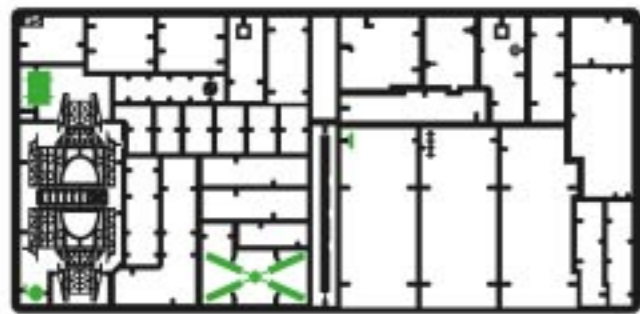

#5

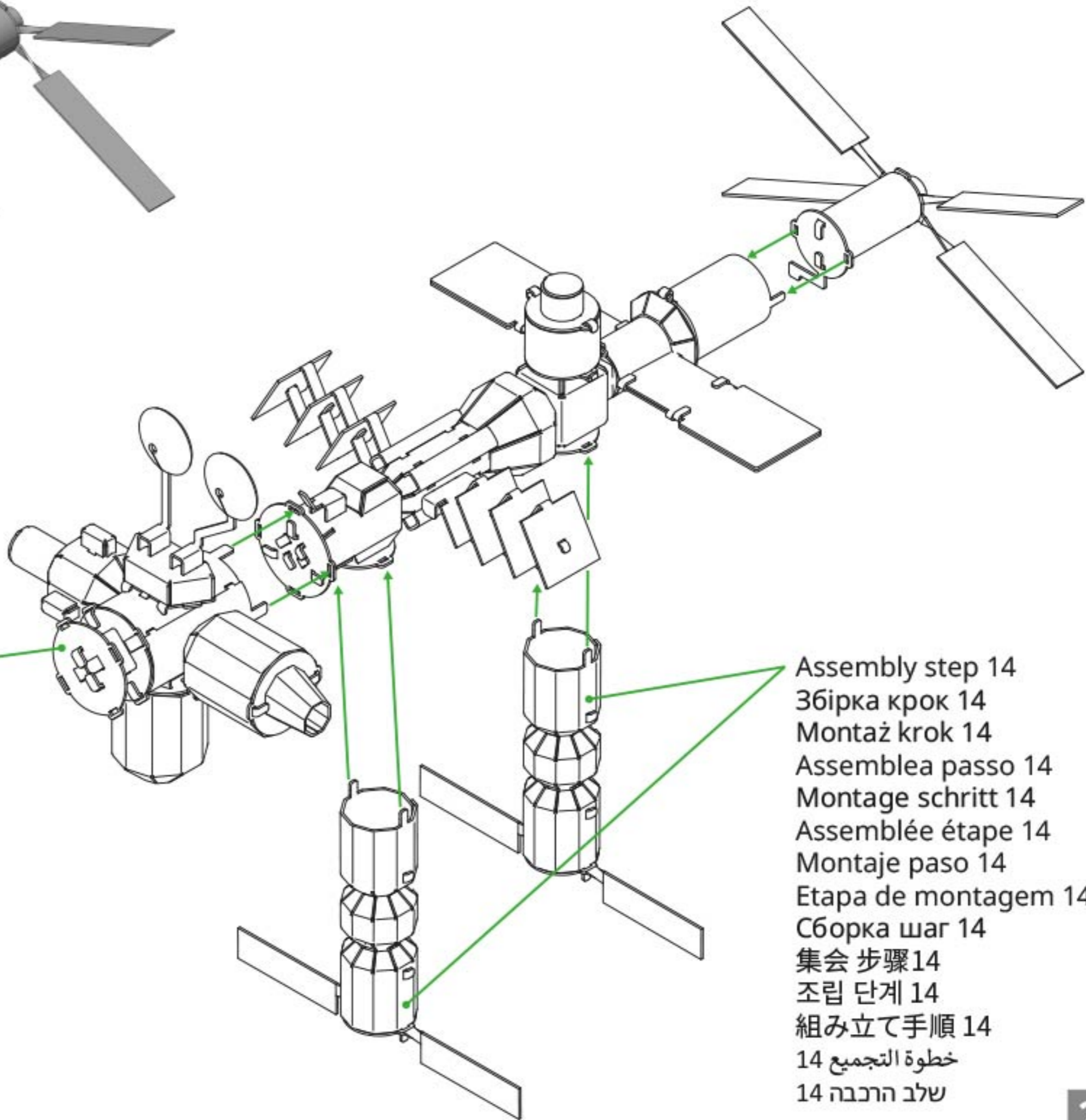
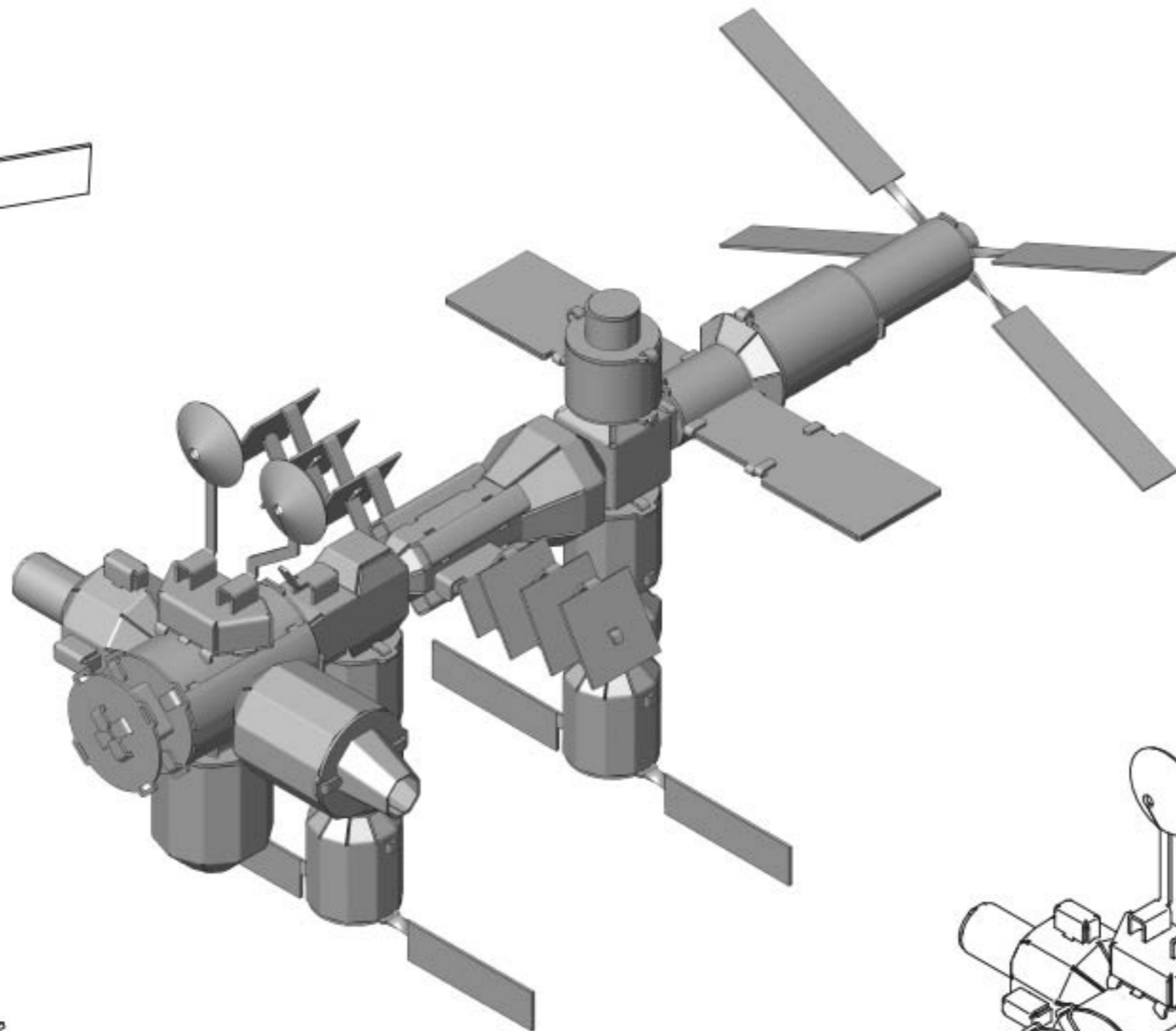
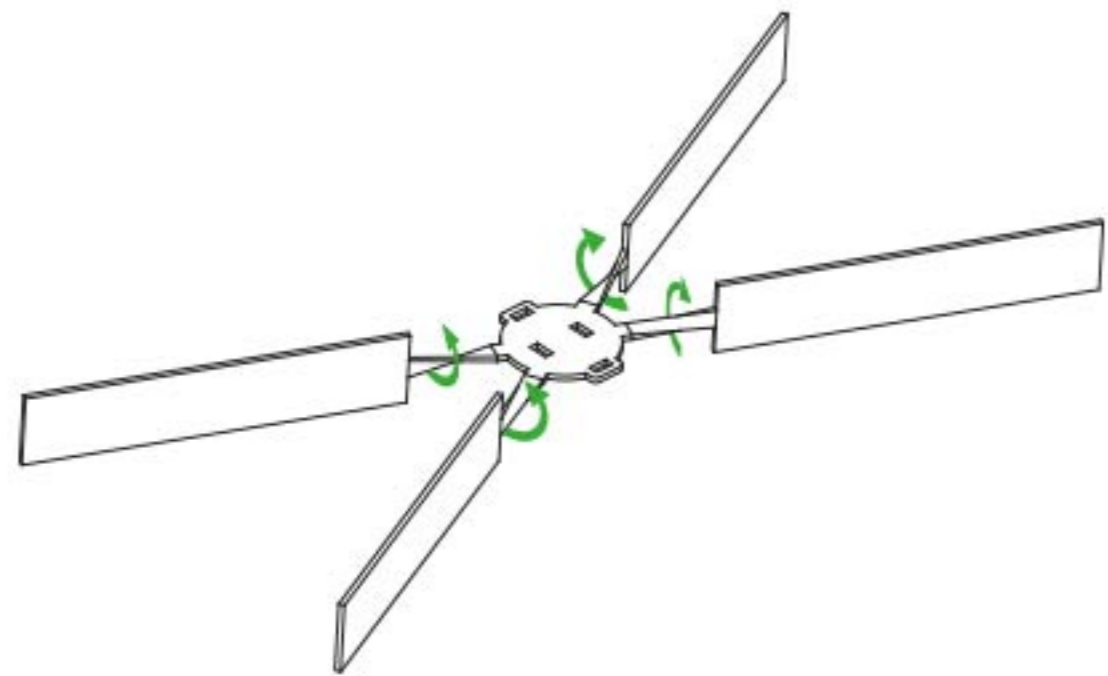

Assembly step 16  
 36ipka krok 16  
 Montaż krok 16  
 Assemblea passo 16  
 Montage schritt 16  
 Assemblée étape 16  
 Montaje paso 16  
 Etapa de montagem 16  
 Сборка шаг 16  
 集会 步骤16  
 조립 단계 16  
 組み立て手順 16  
 خطوة التجميع 16  
 שלב הרכבה 16

Assembly step 14  
 36ipka krok 14  
 Montaż krok 14  
 Assemblea passo 14  
 Montage schritt 14  
 Assemblée étape 14  
 Montaje paso 14  
 Etapa de montagem 14  
 Сборка шаг 14  
 集会 步骤14  
 조립 단계 14  
 組み立て手順 14  
 خطوة التجميع 14  
 שלב הרכבה 14

Assembly step 9  
36ipka krok 9  
Montaż krok 9  
Assemblea passo 9  
Montage schritt 9  
Assemblée étape 9  
Montaje paso 9  
Etap de montagem 9  
Сборка шаг 9  
集会 步骤9  
조립 단계 9  
組み立て手順 9  
خطوة التجميع 9  
שלב הרכבה 9

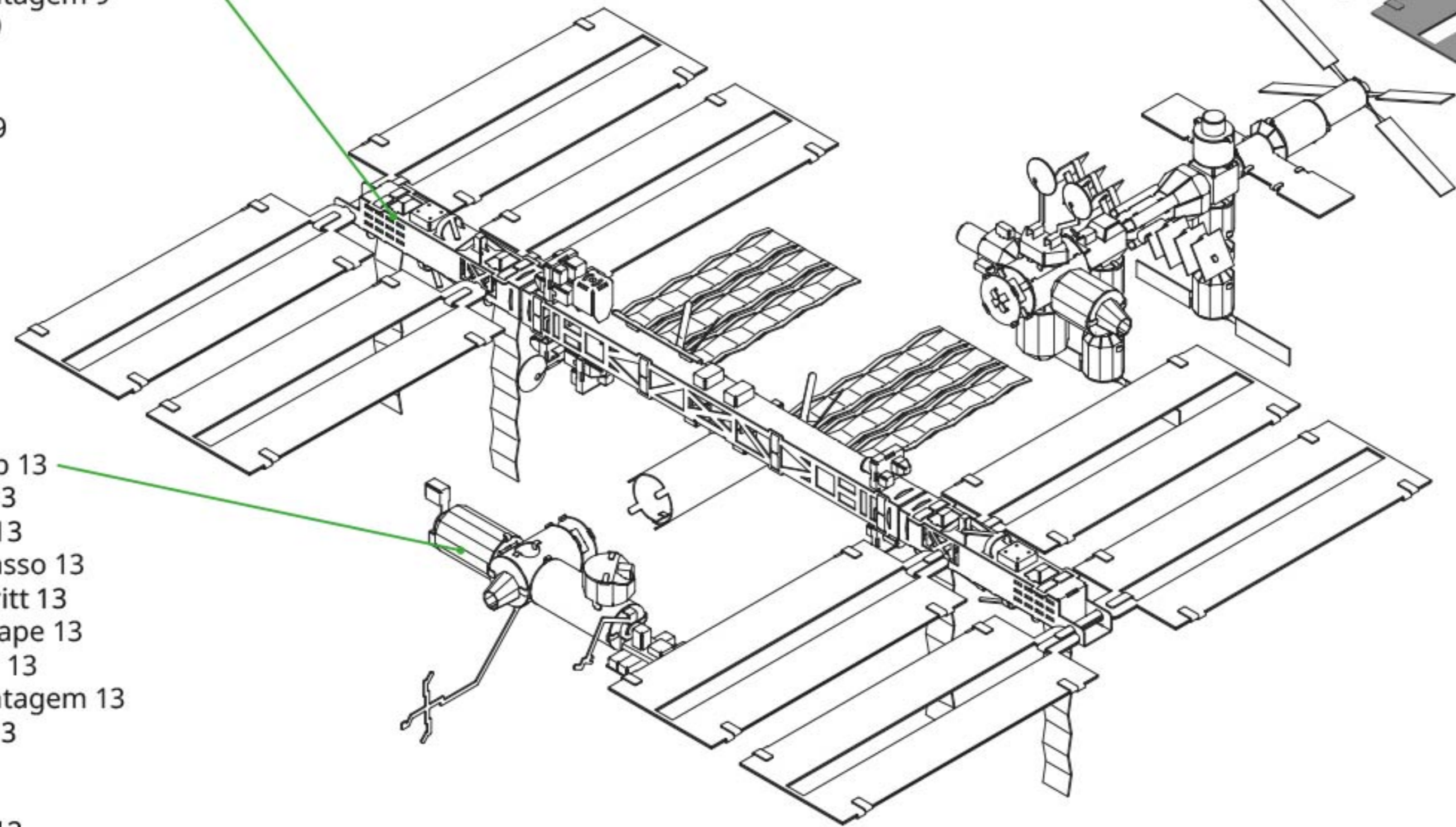

Assembly step 13  
36ipka krok 13  
Montaż krok 13  
Assemblea passo 13  
Montage schritt 13  
Assemblée étape 13  
Montaje paso 13  
Etap de montagem 13  
Сборка шаг 13  
集会 步骤13  
조립 단계 13  
組み立て手順 13  
خطوة التجميع 13  
שלב הרכבה 13

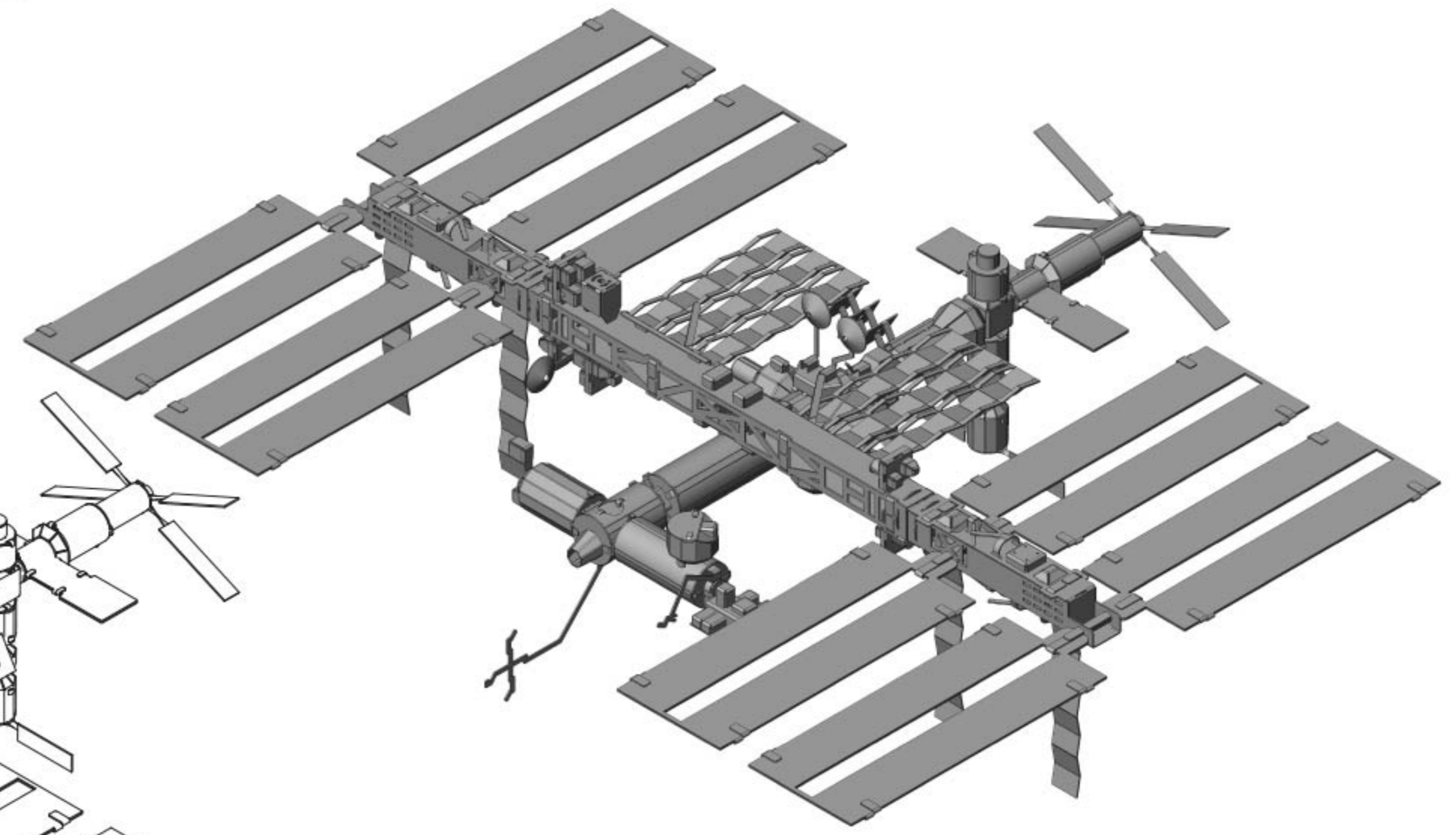

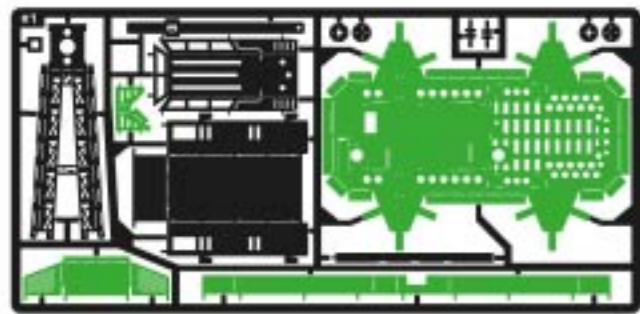

#1



#2

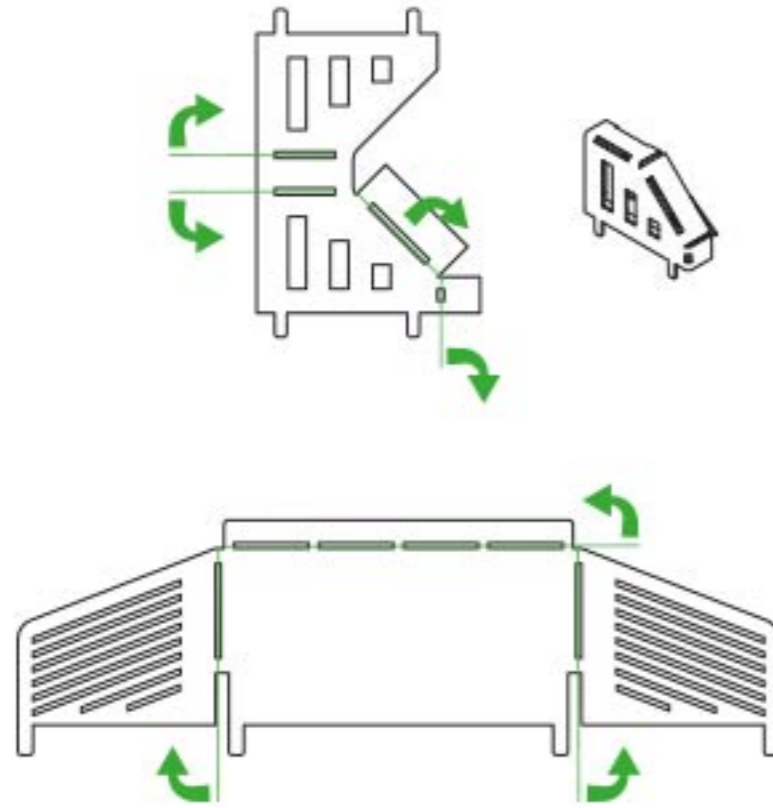

Battery holder  
 Тримач батарейок  
 Uchwyt baterii  
 Portabatterie  
 Batteriehalter  
 Support de batterie  
 Soporte de la batería  
 Suporte da bateria  
 Держатель батареек  
 電池座  
 배터리 홀더  
 バッテリーホルダー  
 حامل البطارية  
 בעל סוללה

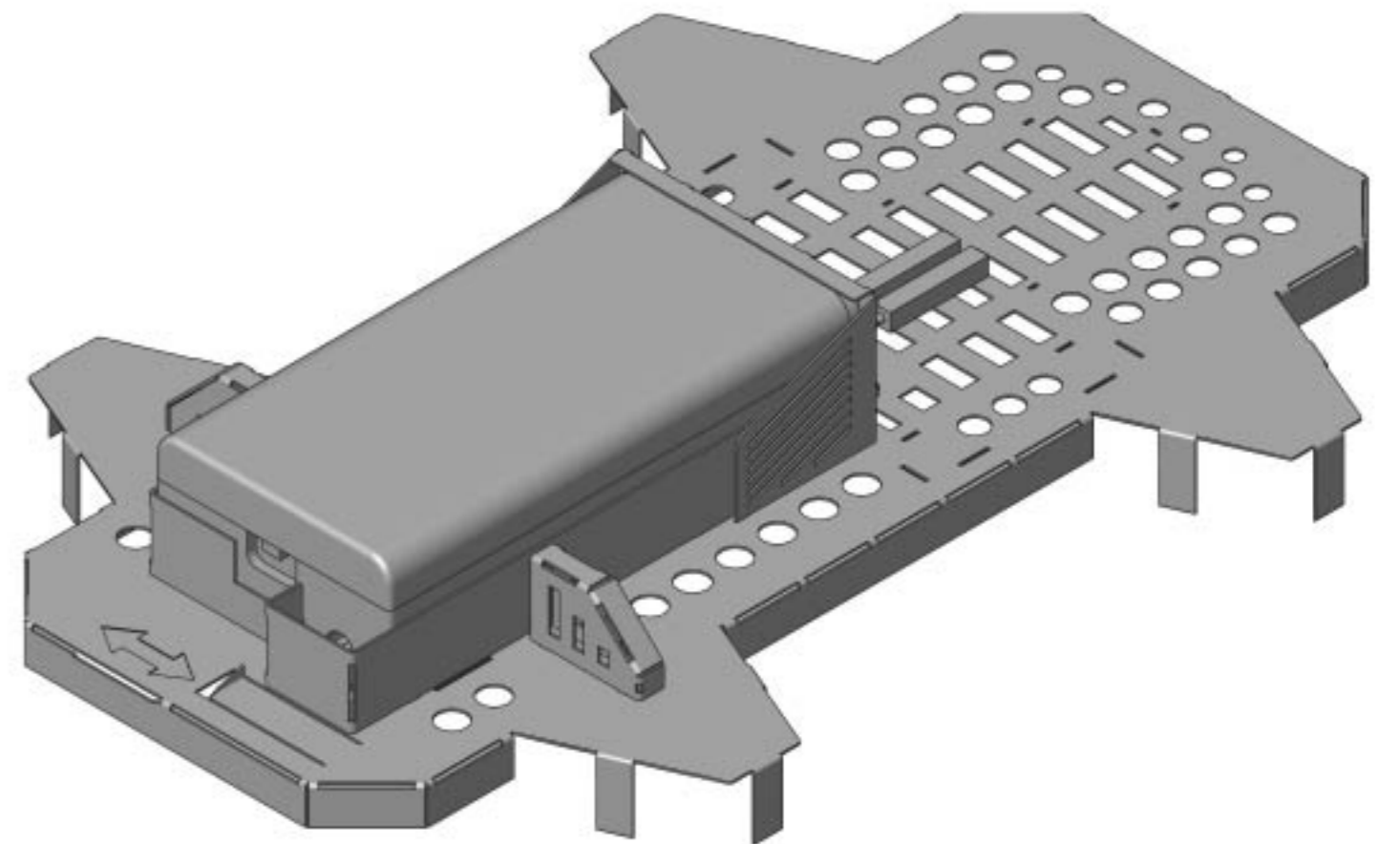
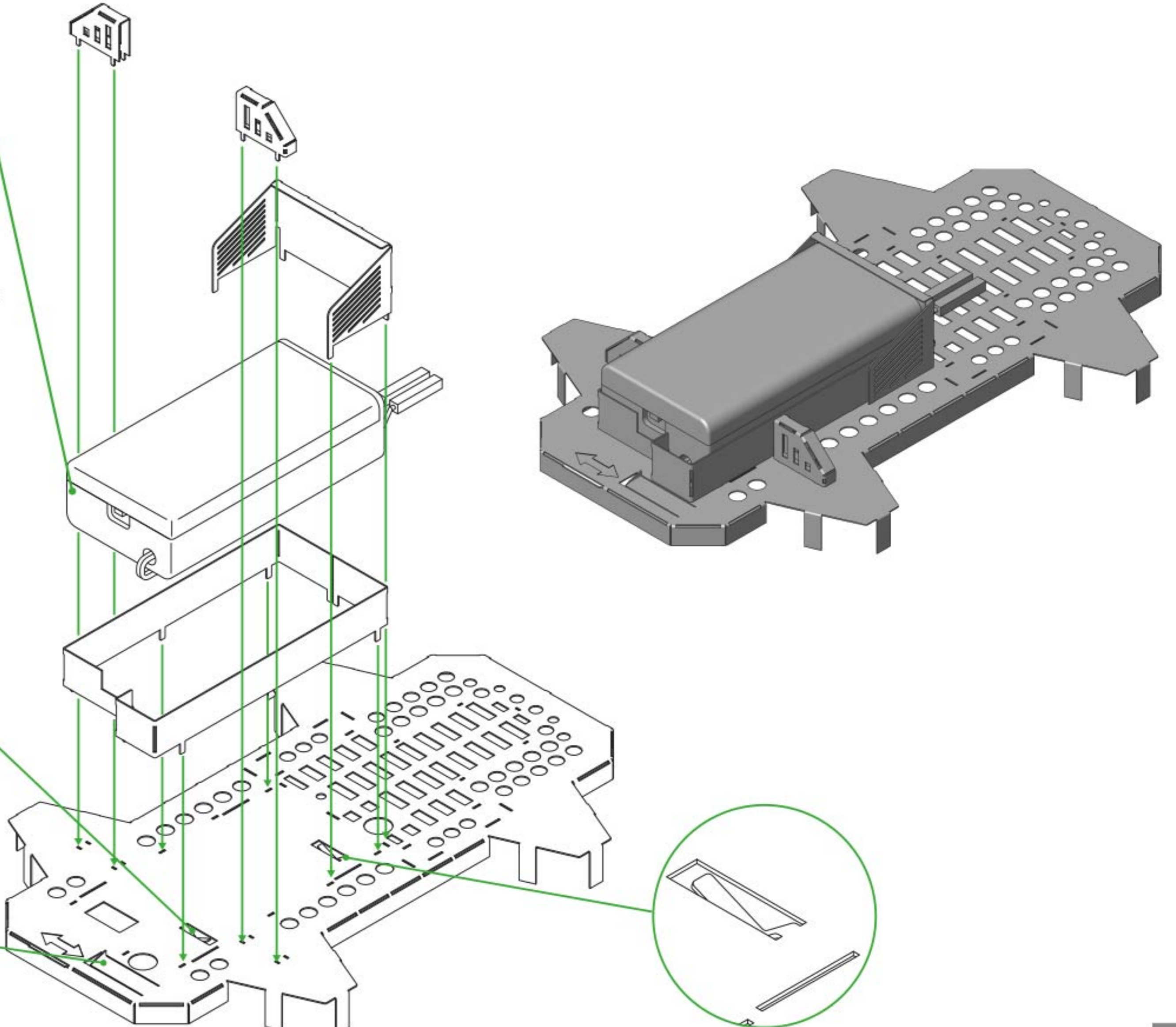
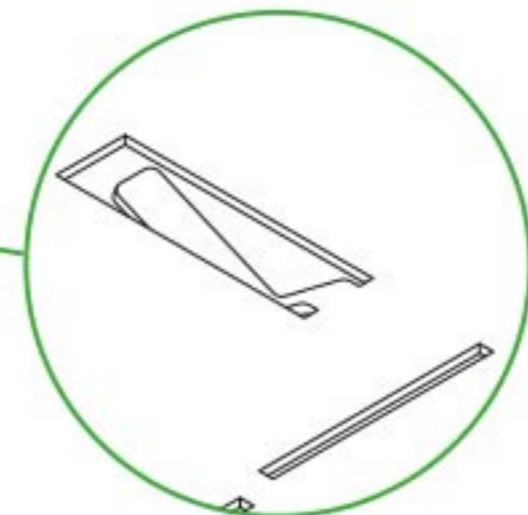
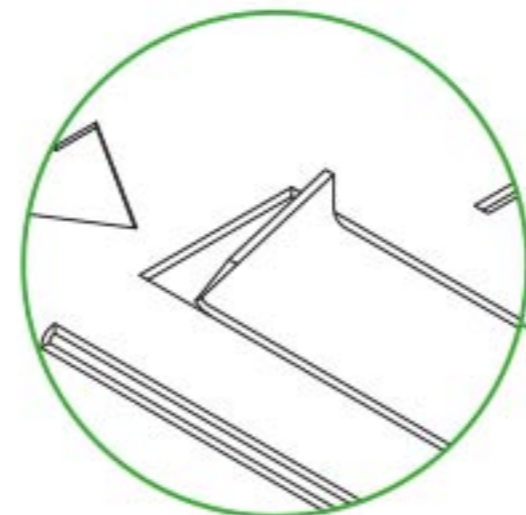
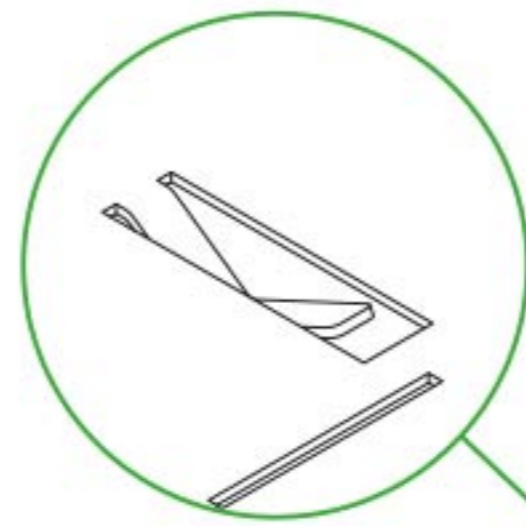
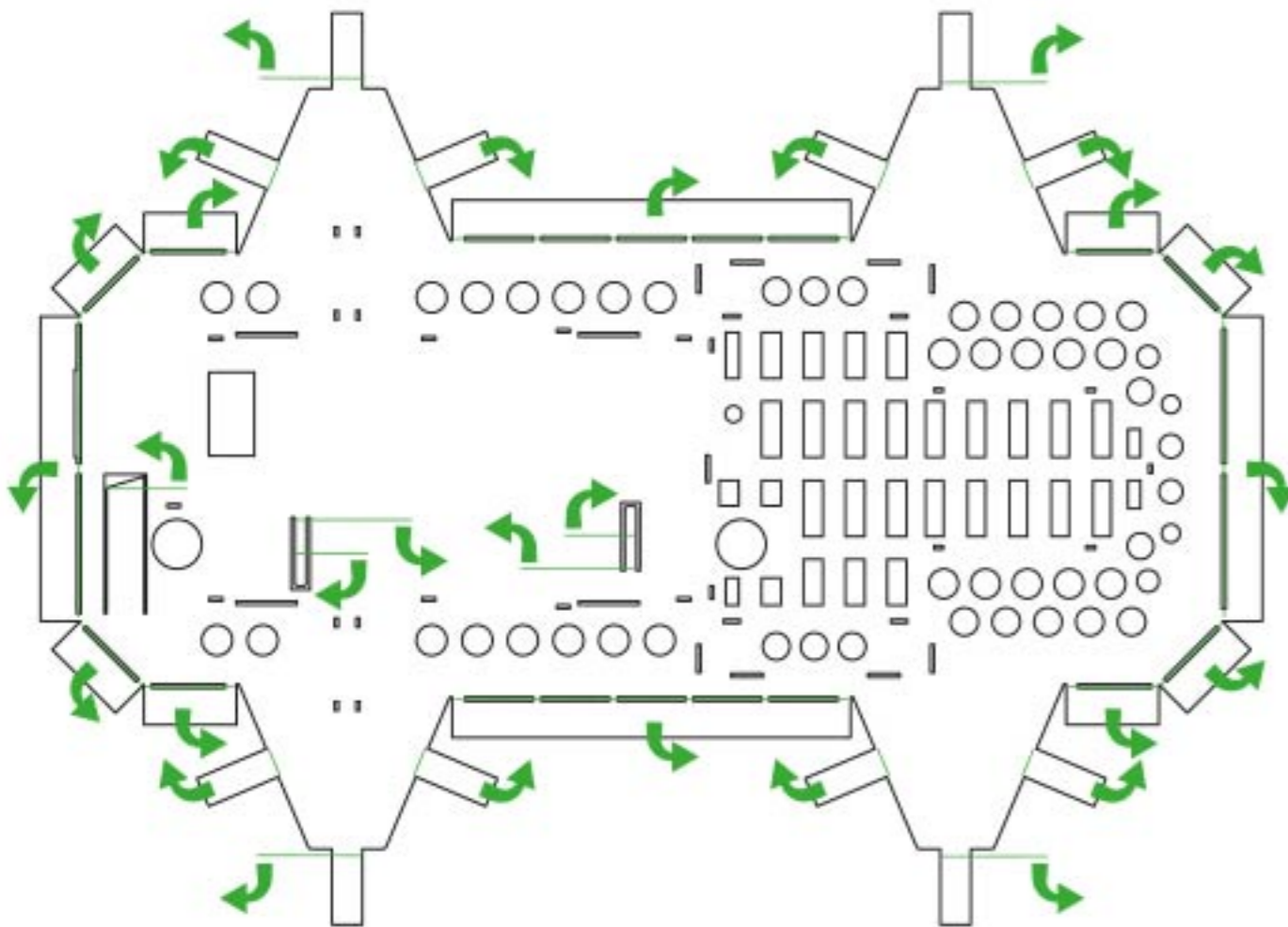
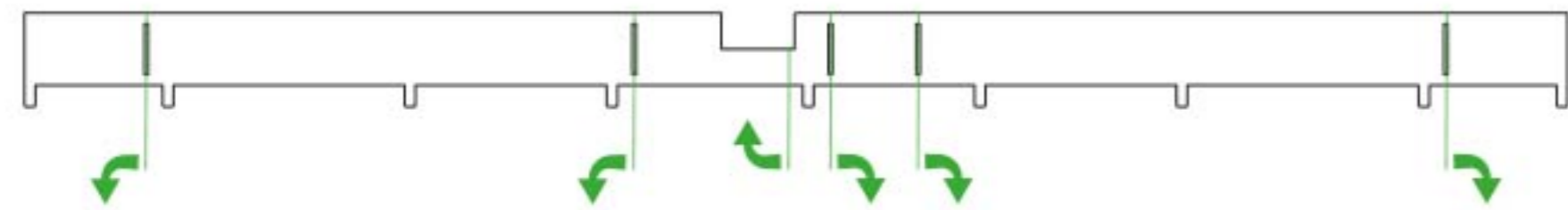



#1



#3

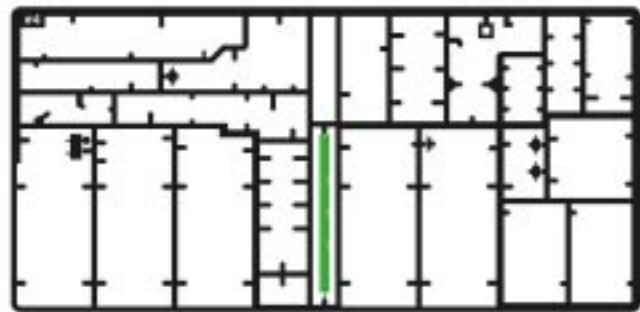

#4

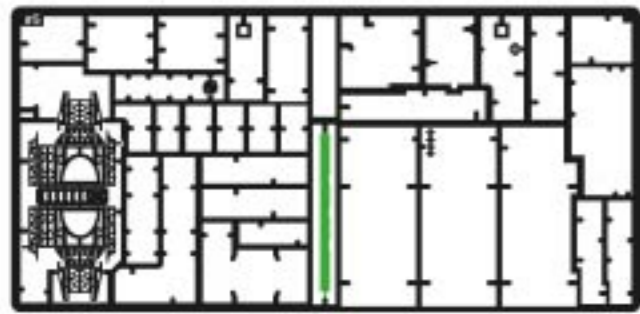

#5

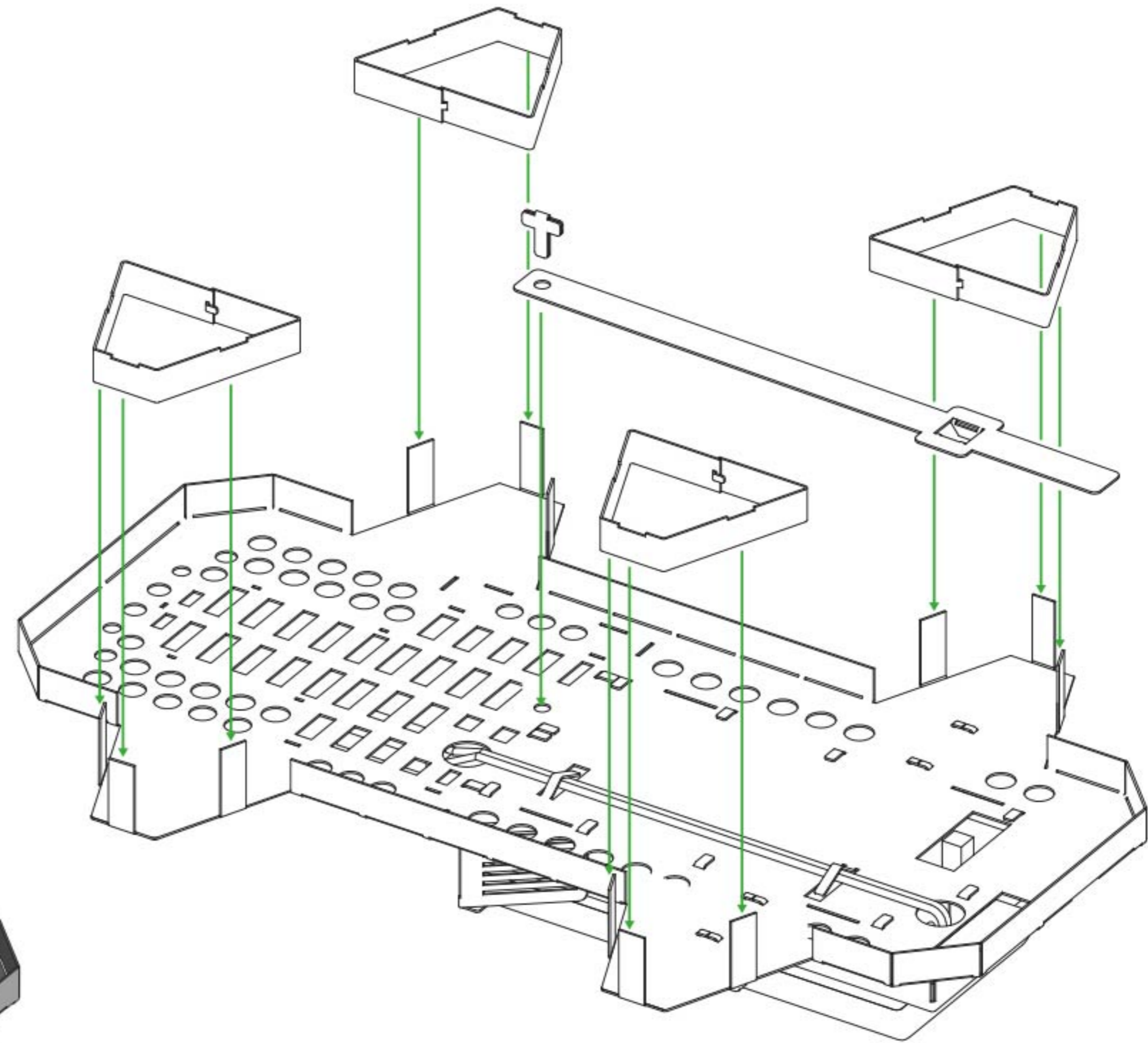
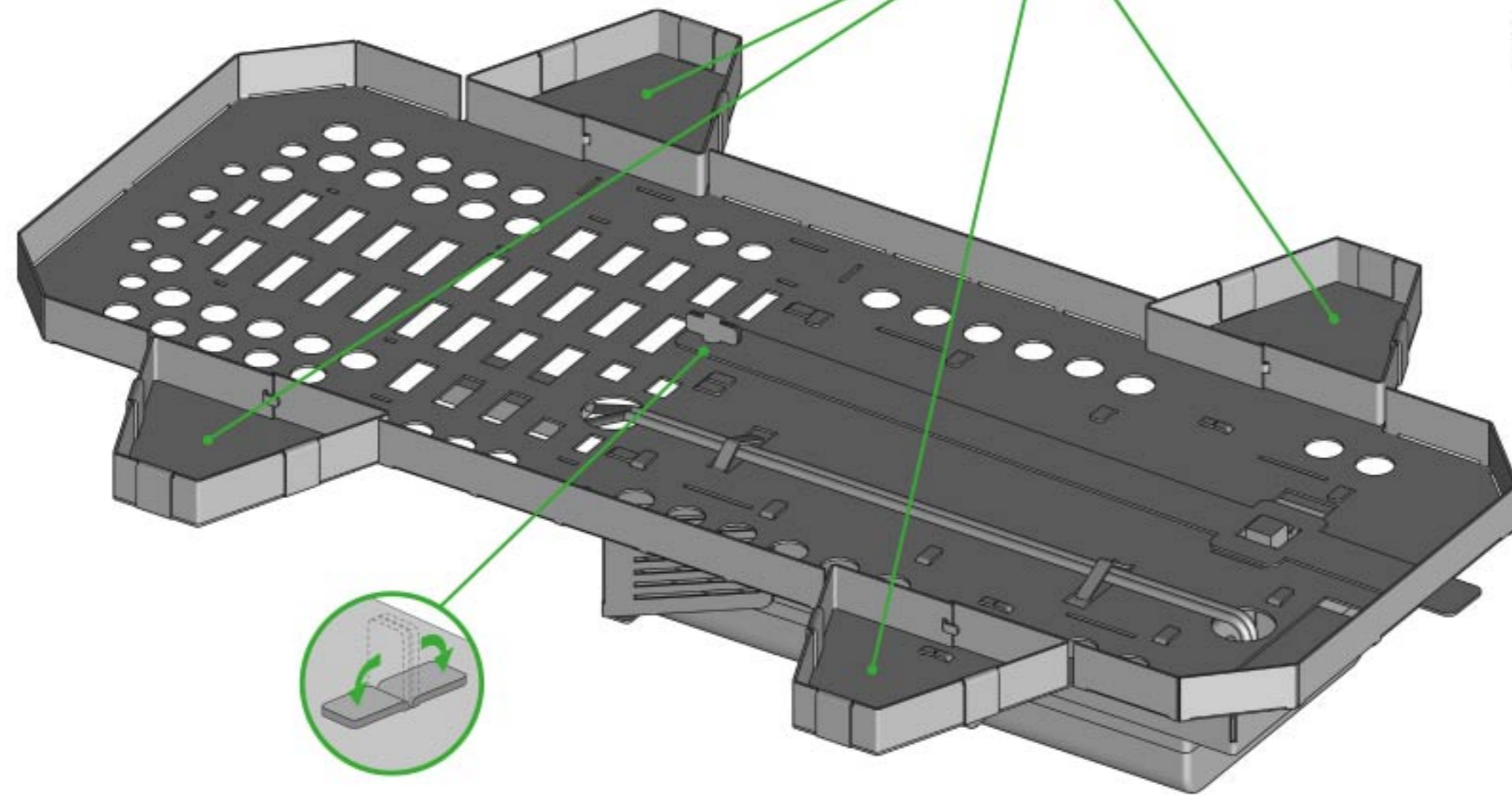
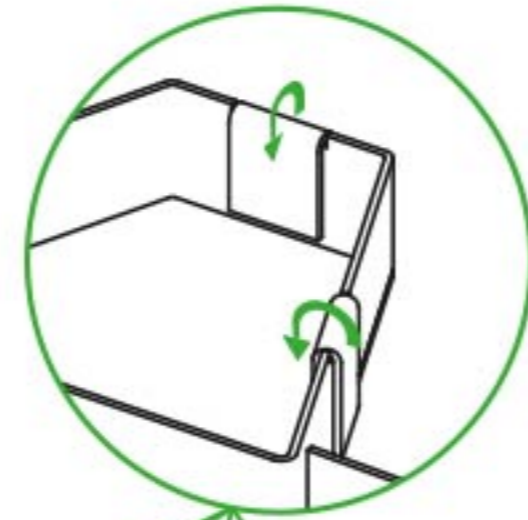
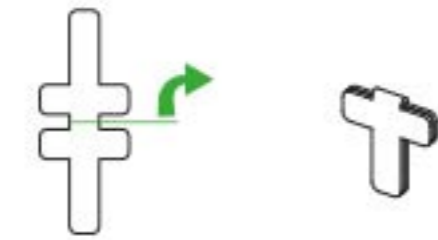
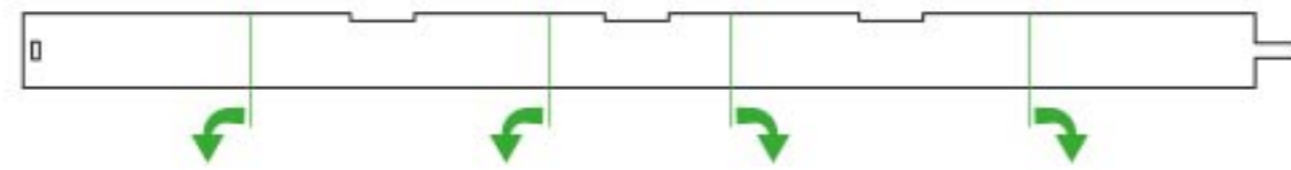

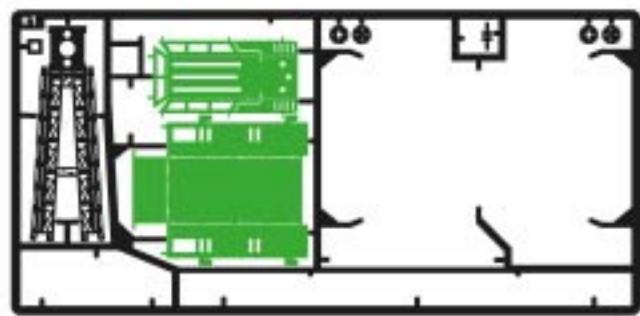

#1

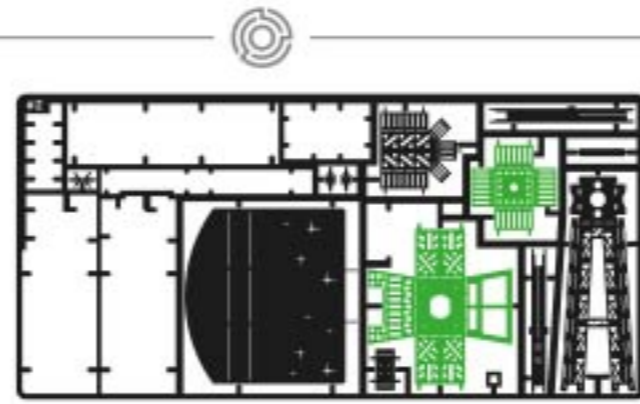
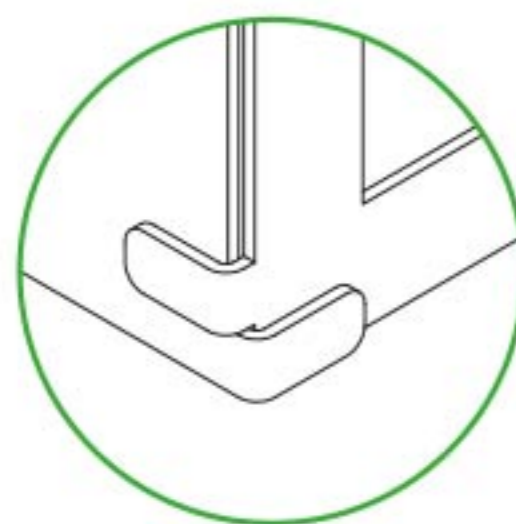
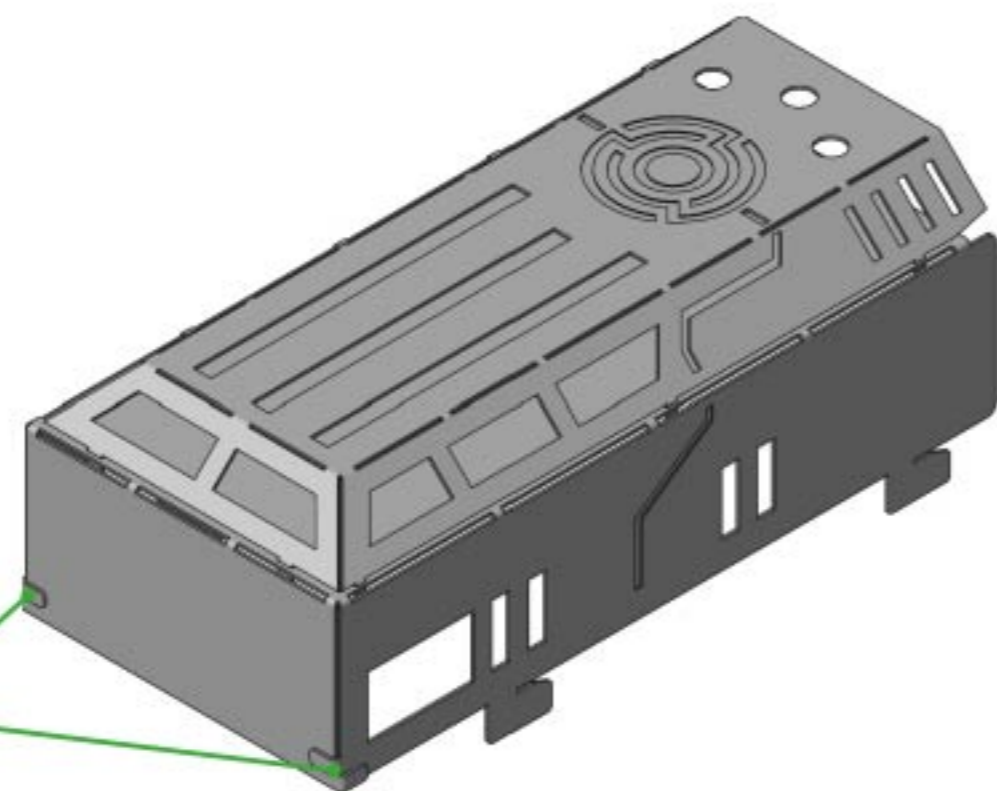
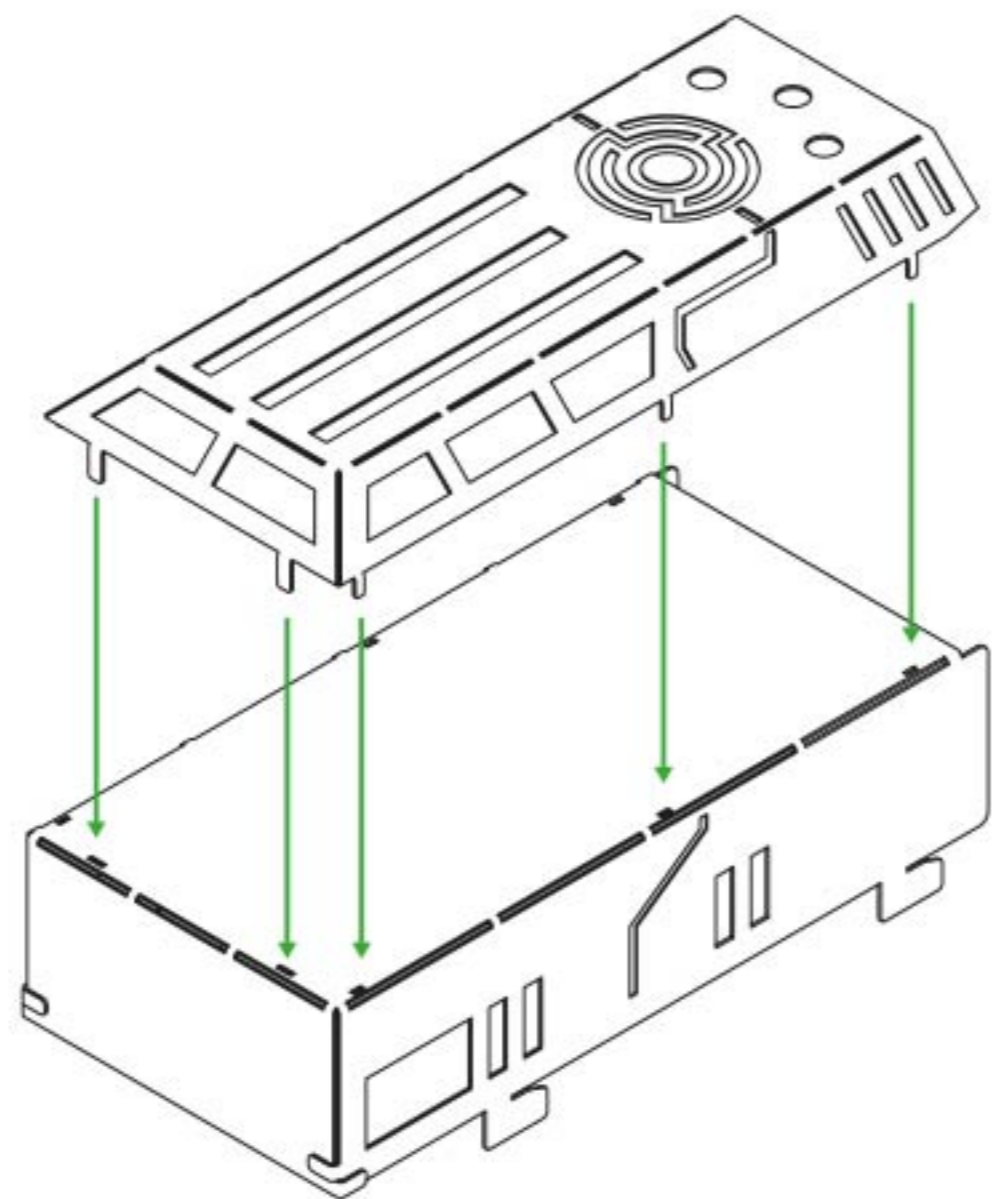
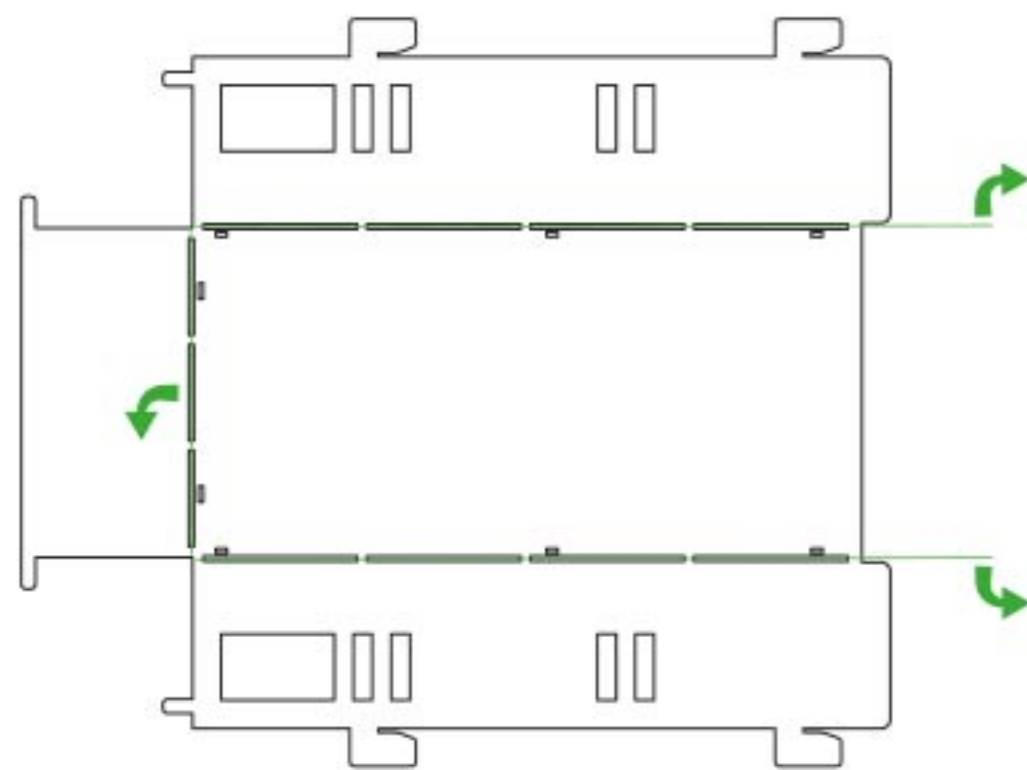
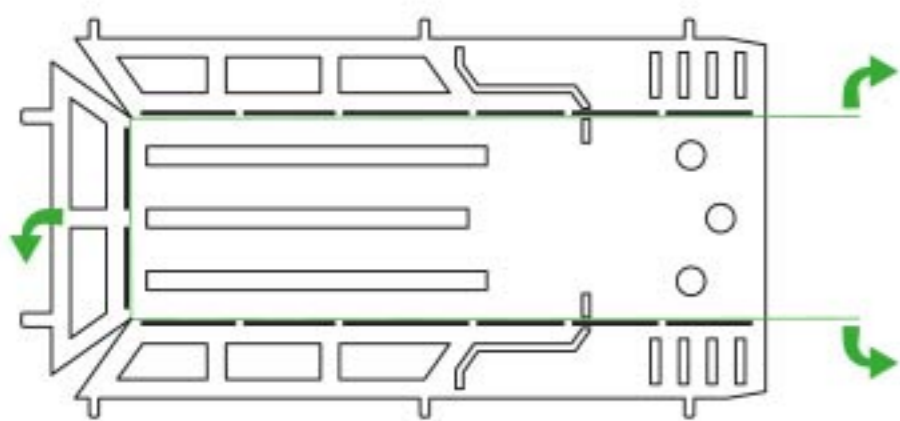

#2

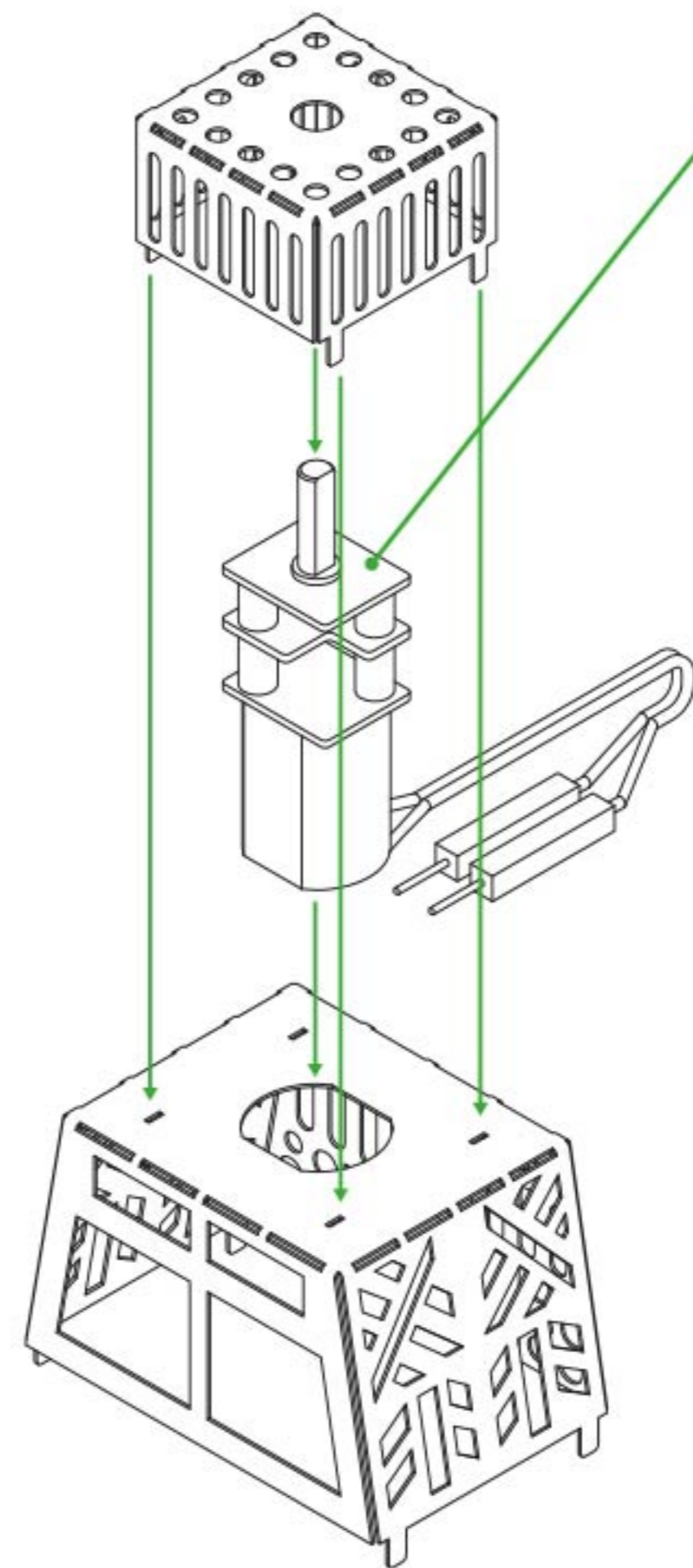
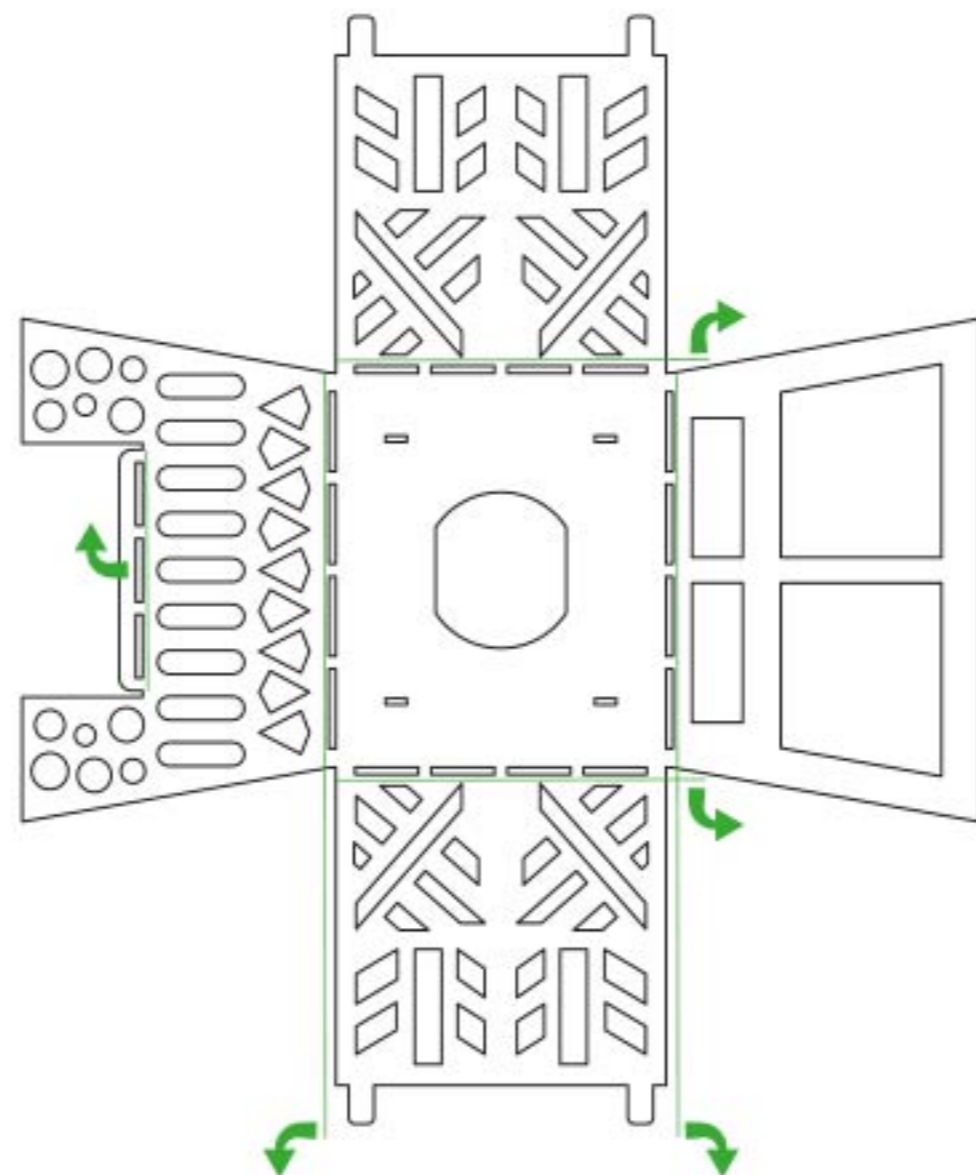
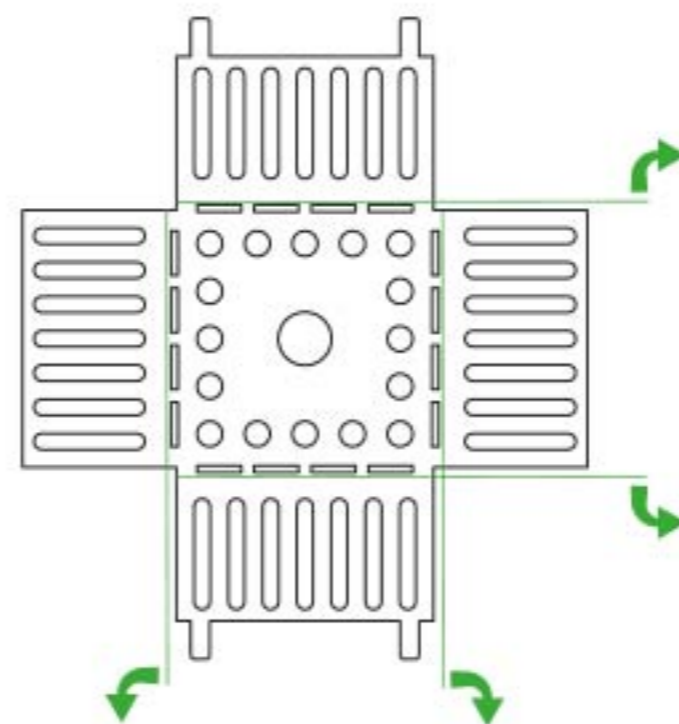

Engine  
 Двигун  
 Silnik  
 Motore  
 Motor  
 Moteur  
 Motor  
 Motor  
 Двигатель  
 引擎  
 엔진  
 エンジン  
 محرك  
 מנוע

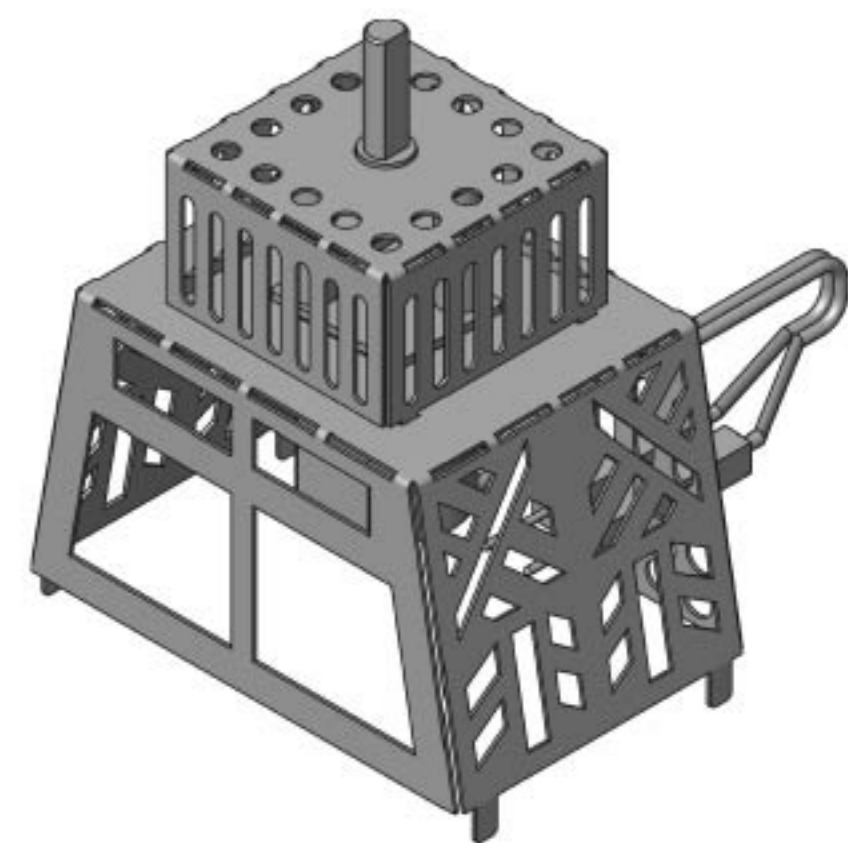



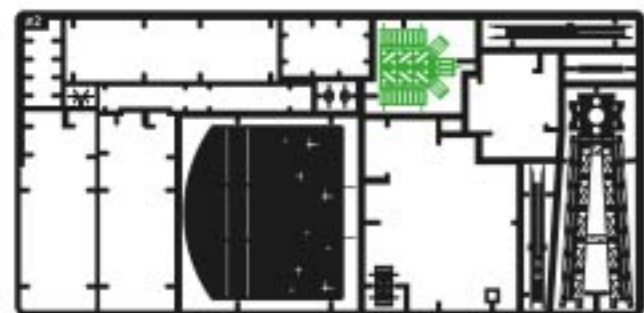

#2

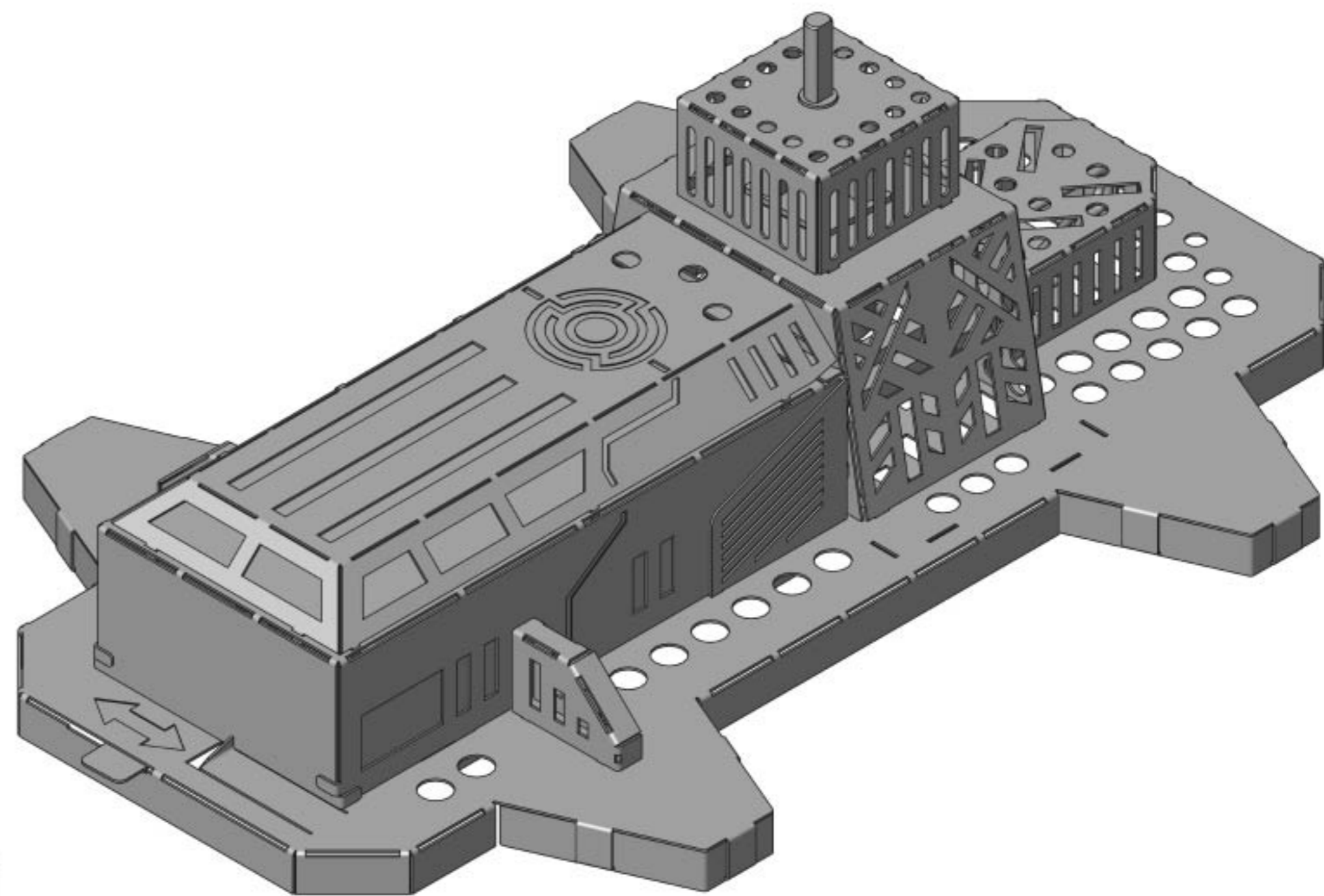
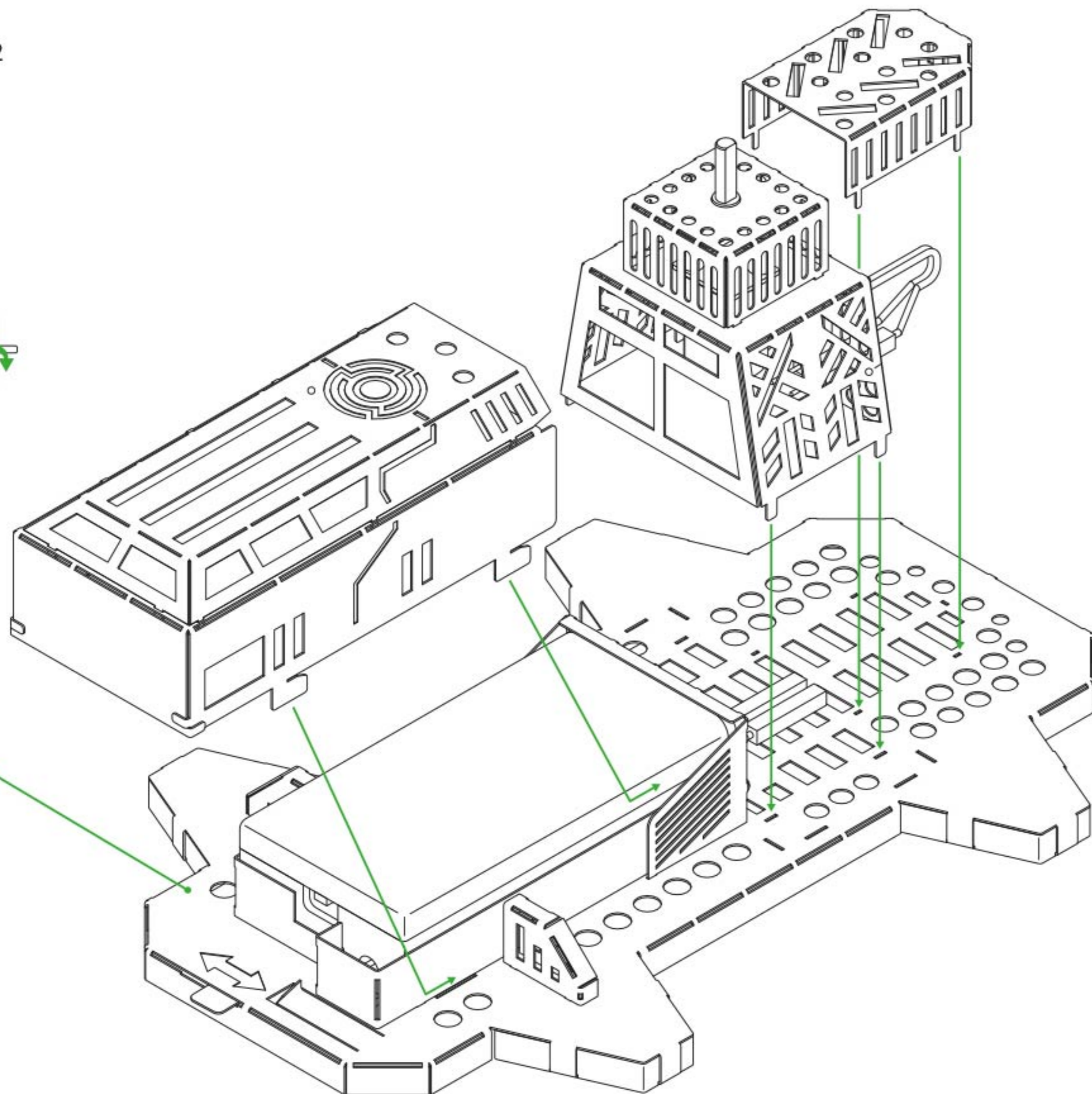
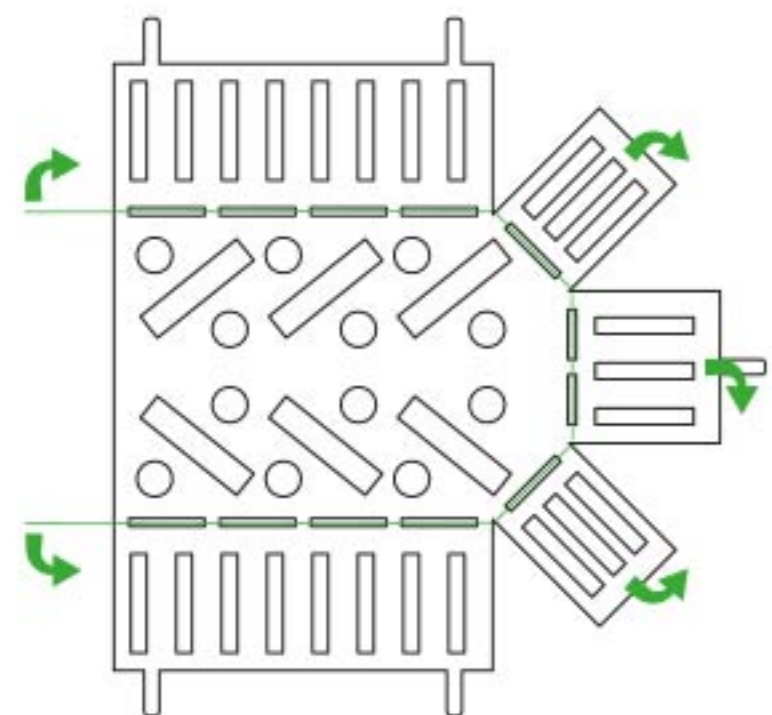

Assembly step 23  
36ipka krok 23  
Montaż krok 23  
Assemblea passo 23  
Montage schritt 23  
Assemblée étape 23  
Montaje paso 23  
Etapă de montaj 23  
Сборка шаг 23  
集会 步骤23  
조립 단계 23  
組み立て手順 23  
خطوة التجميع 23  
שלב הרכבה 23

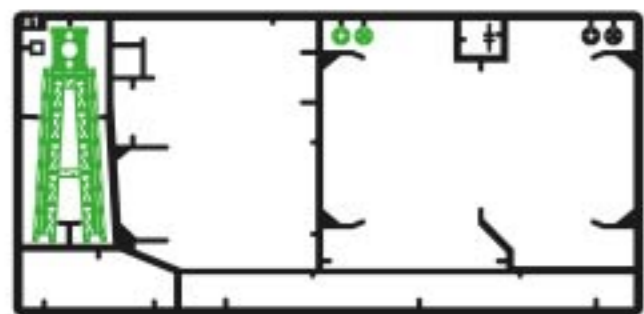

#1

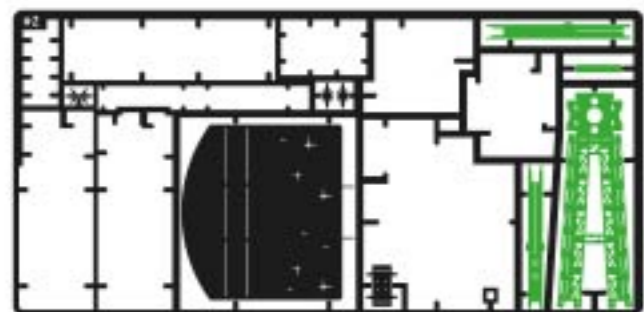

#2

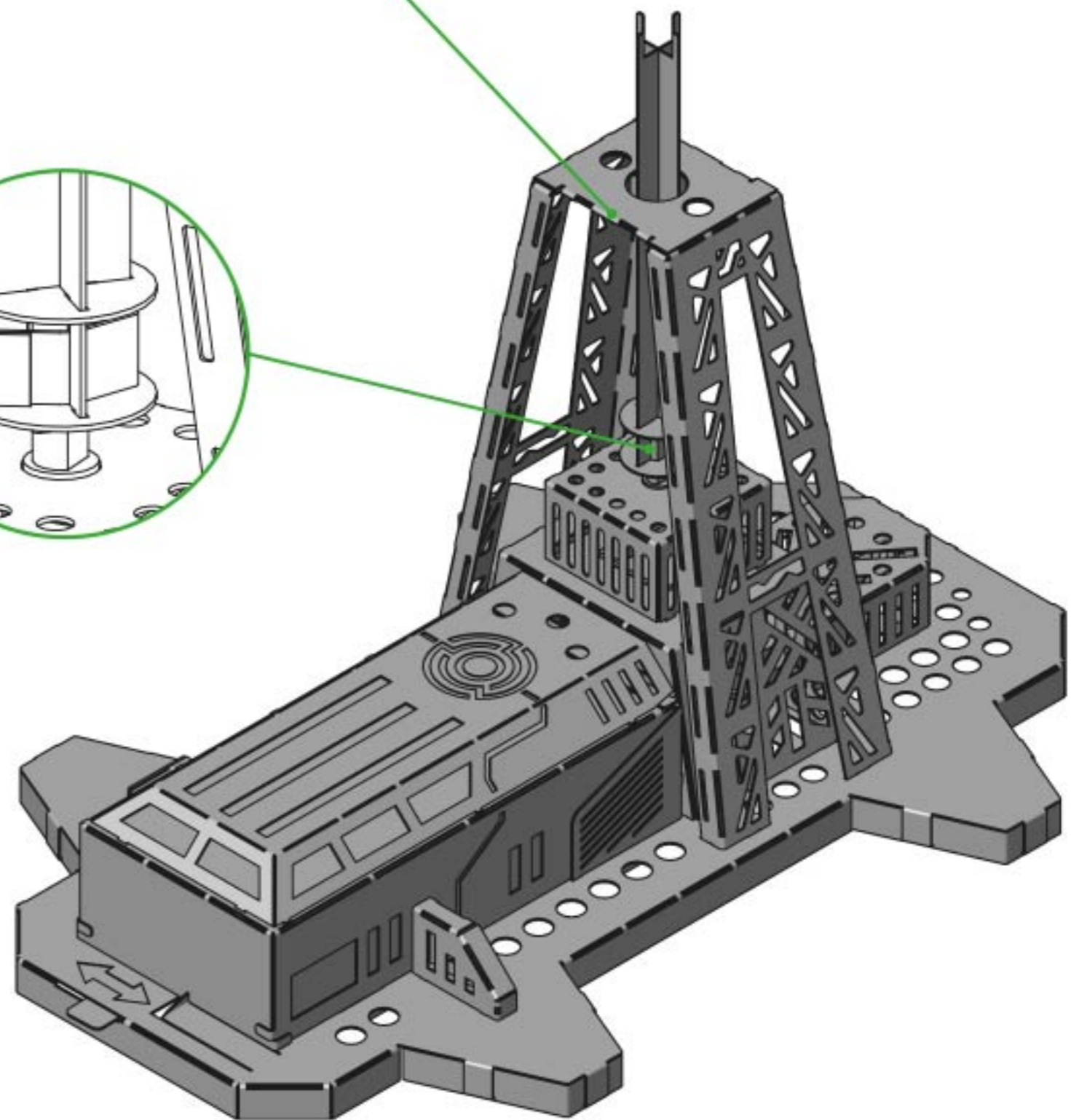
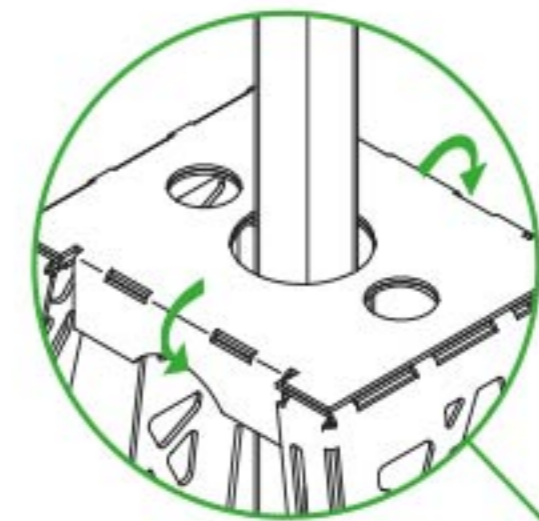
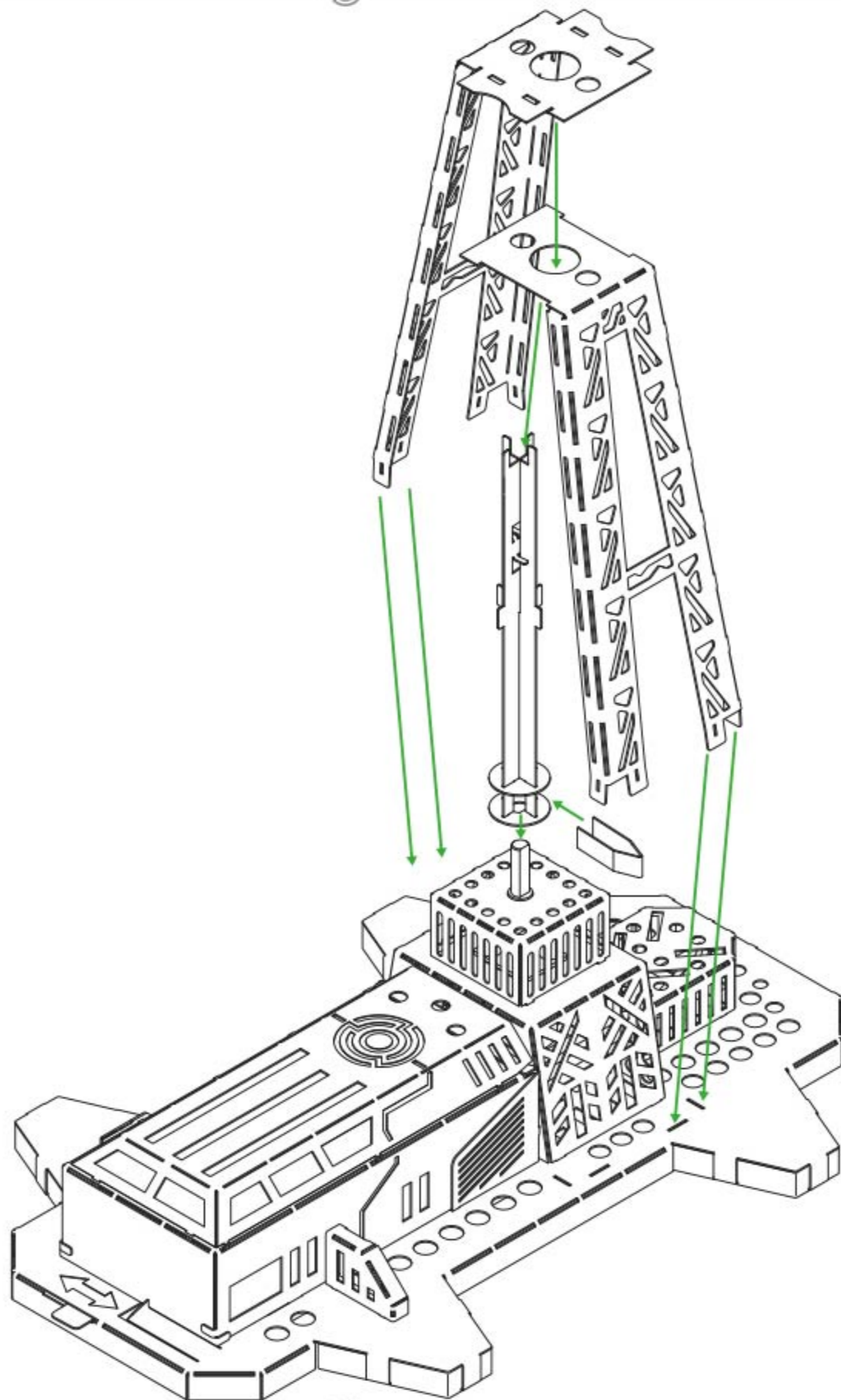
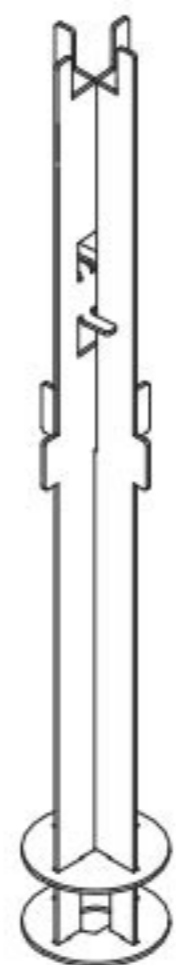
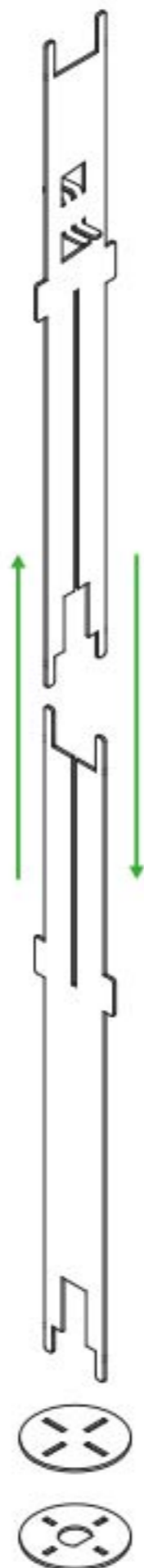
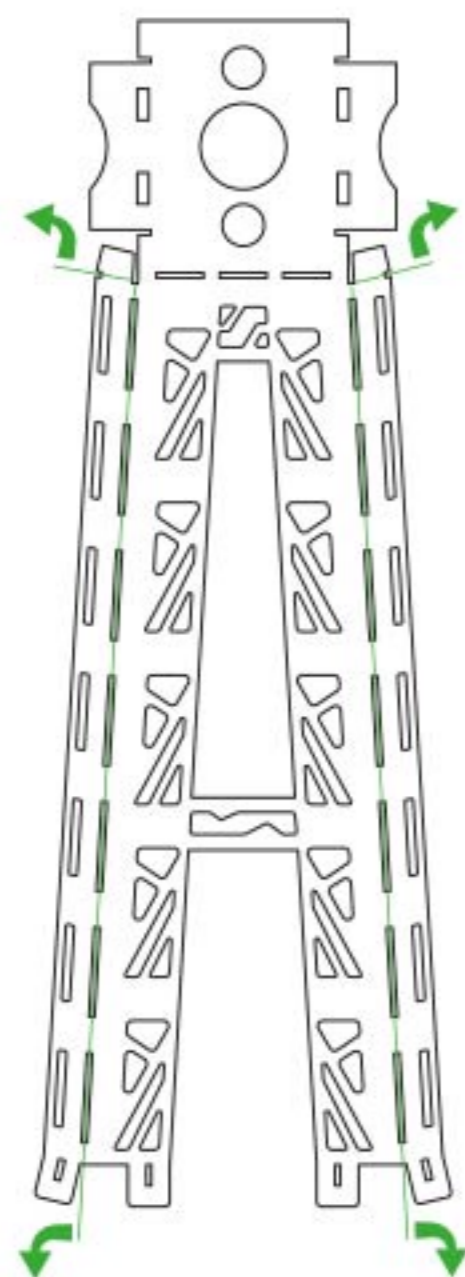
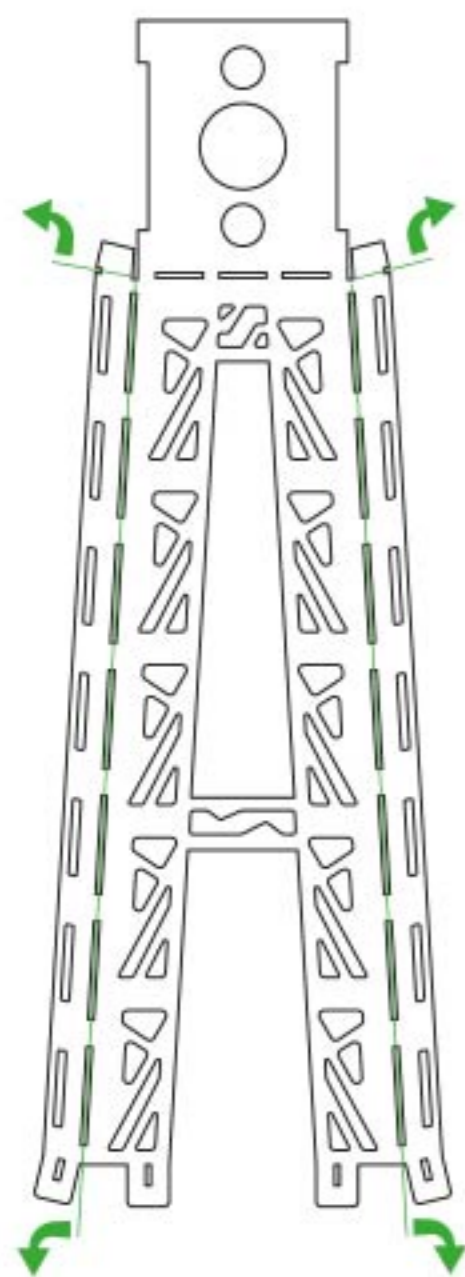
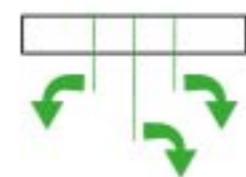
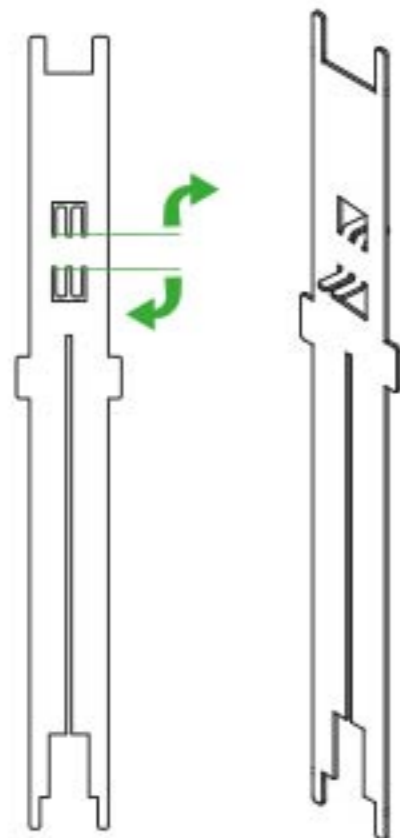

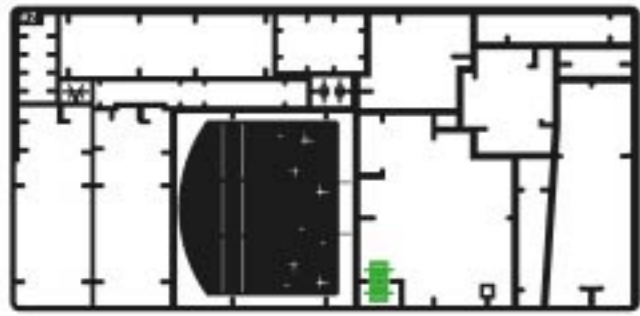

#2

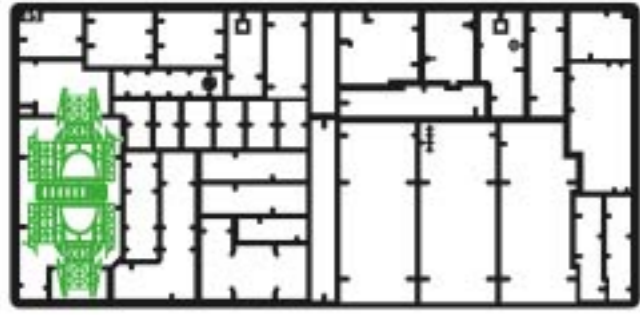

#5

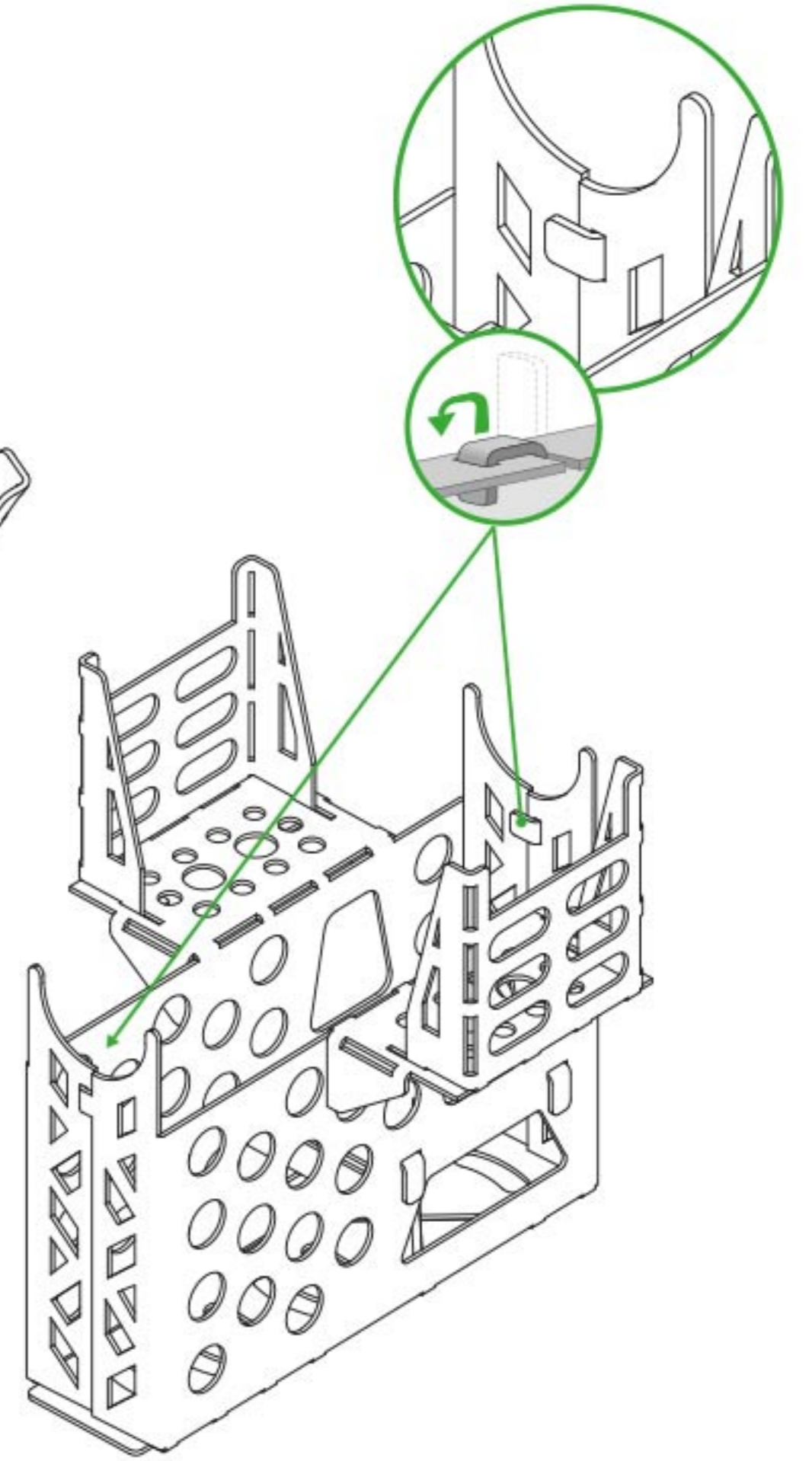
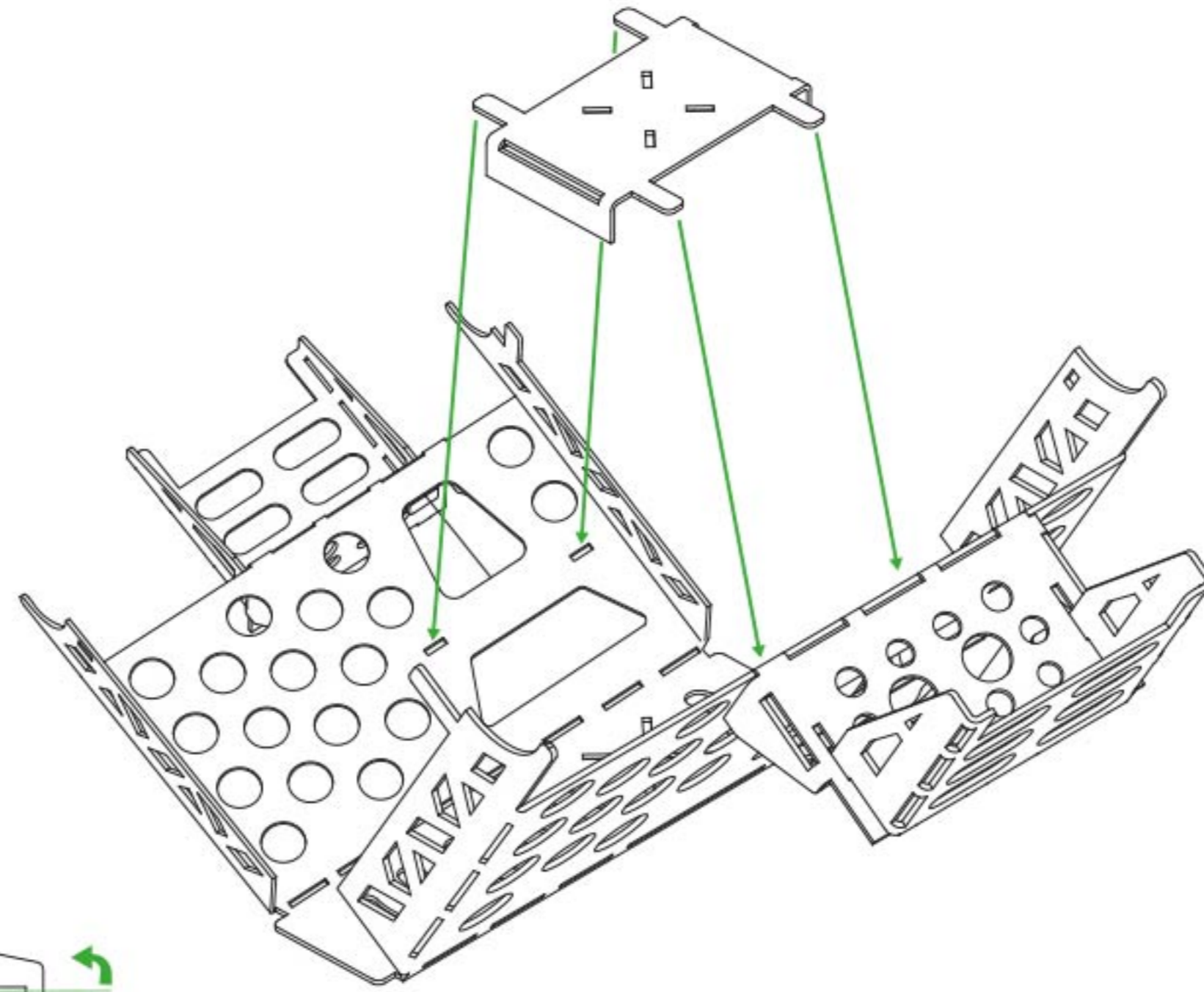
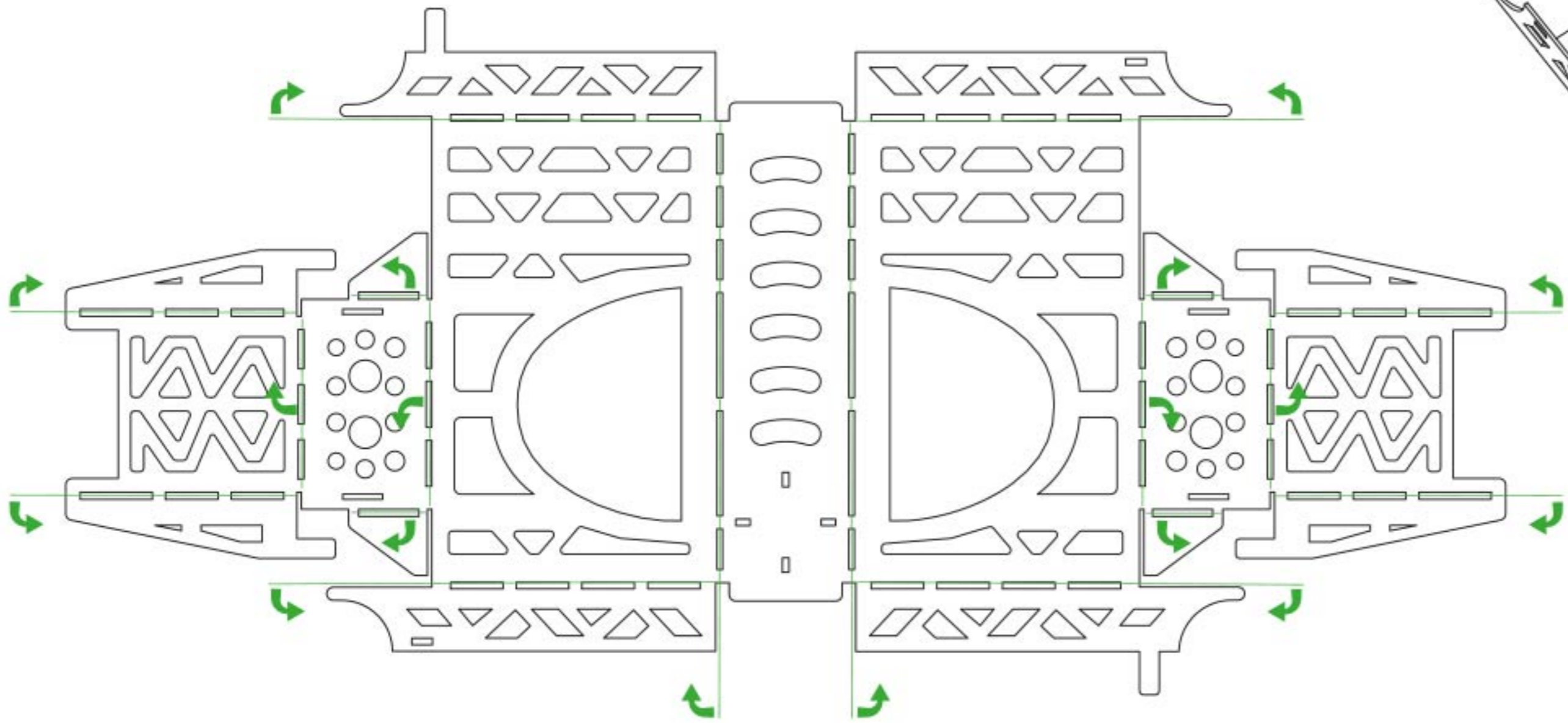
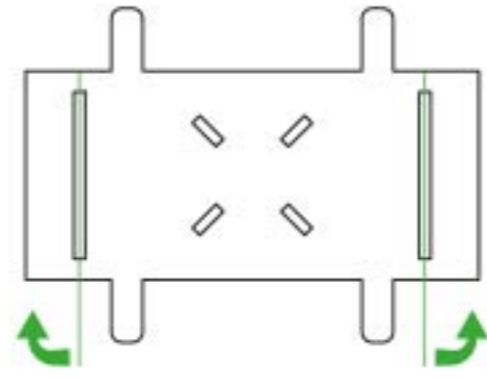



#2

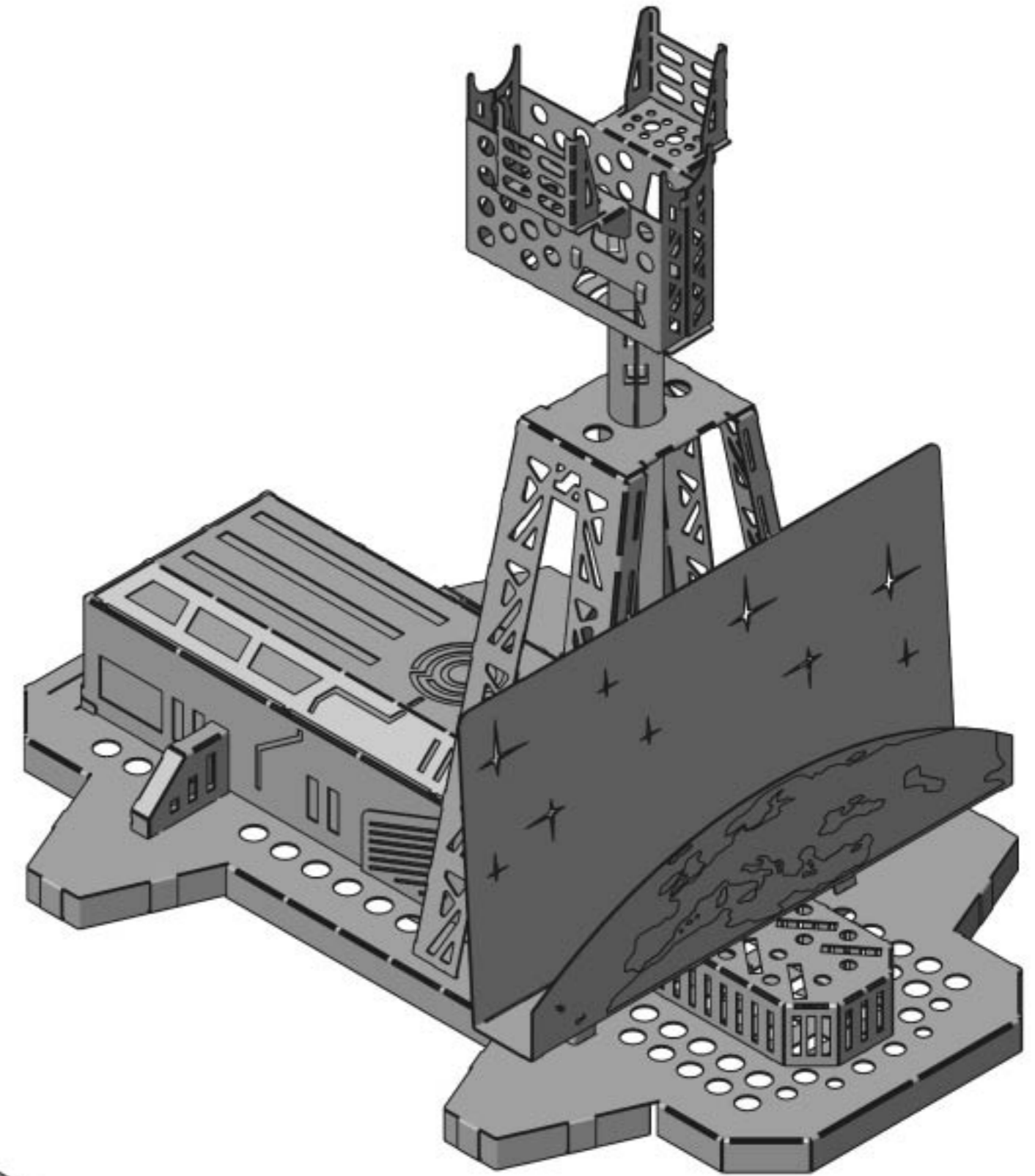
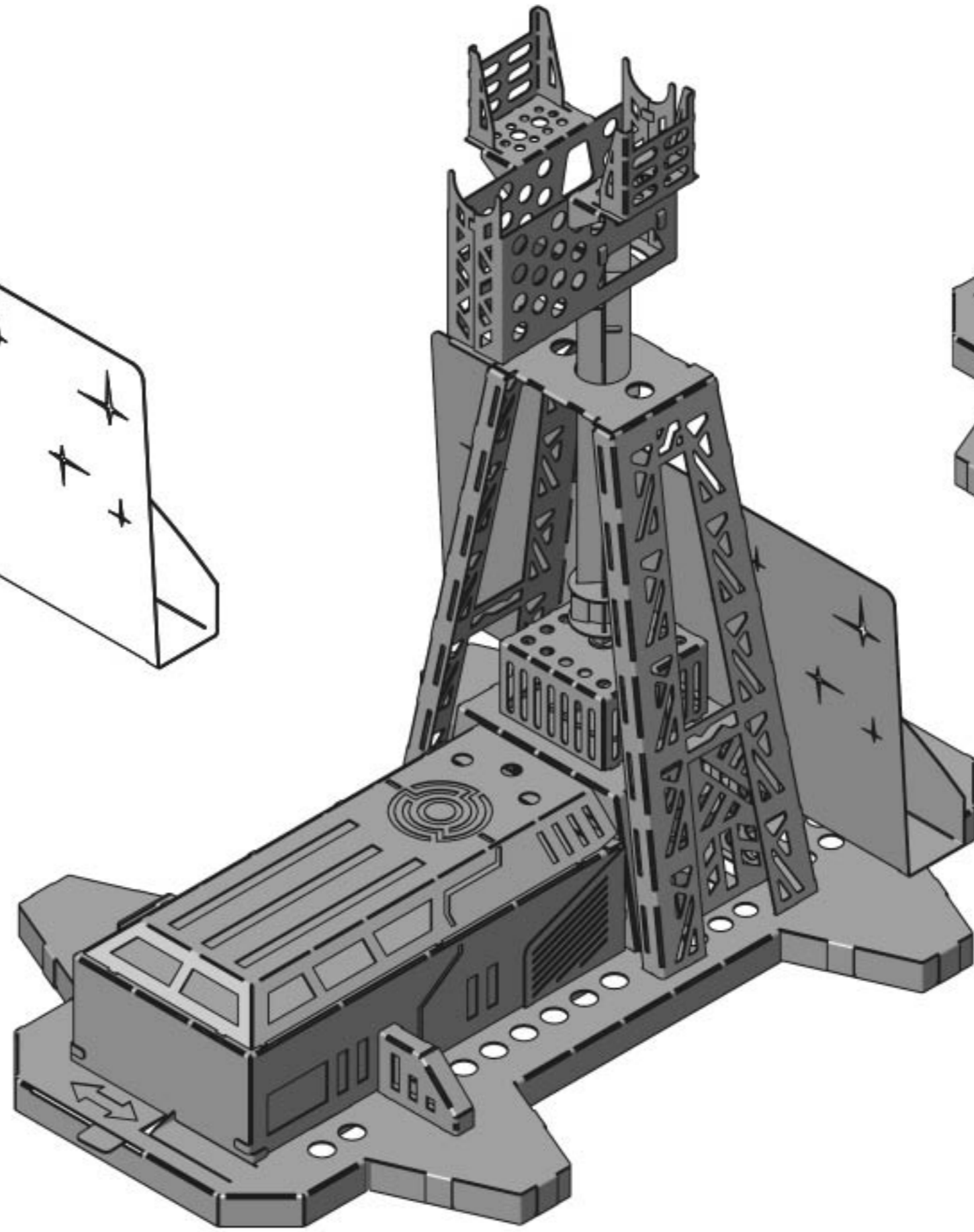
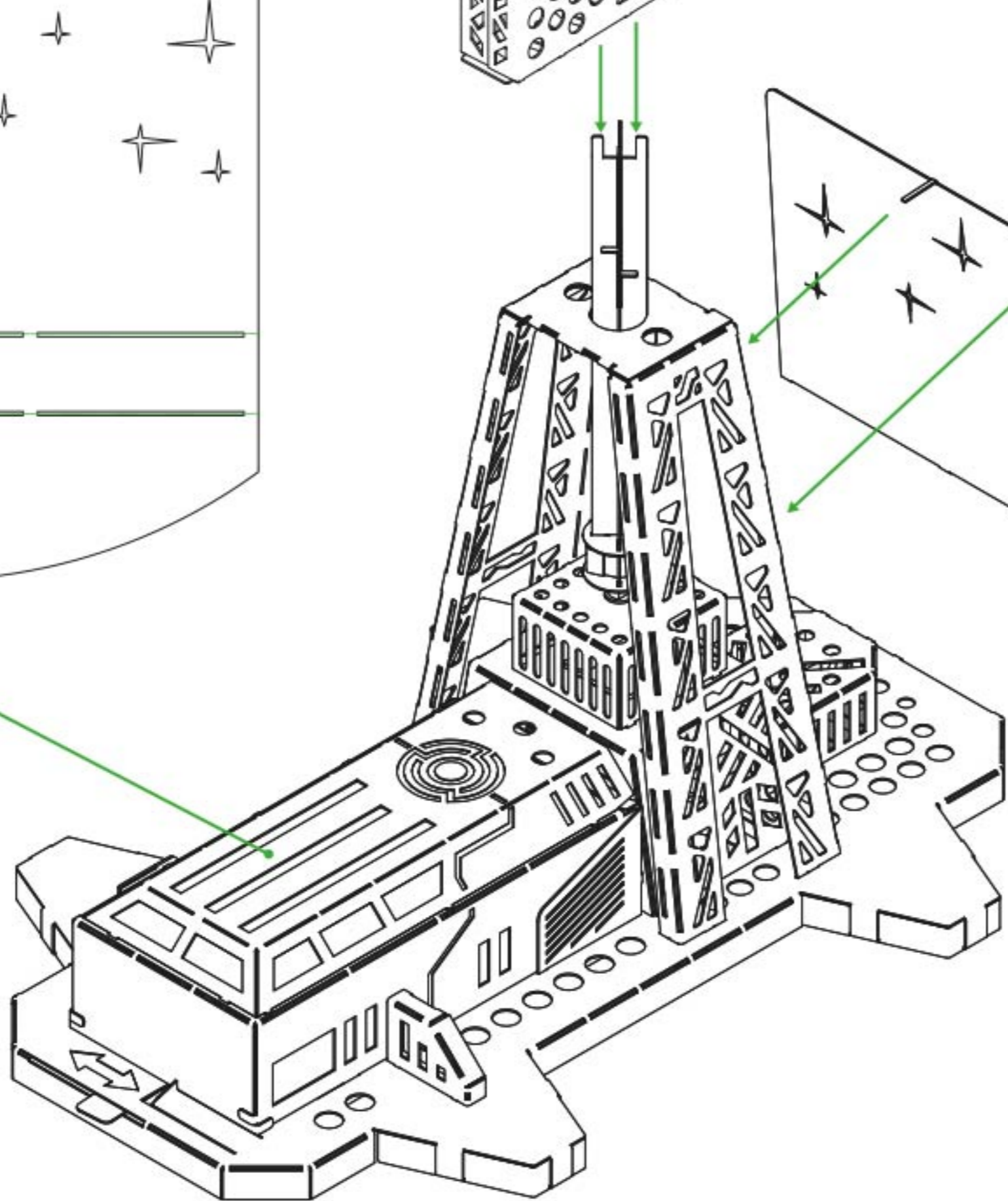
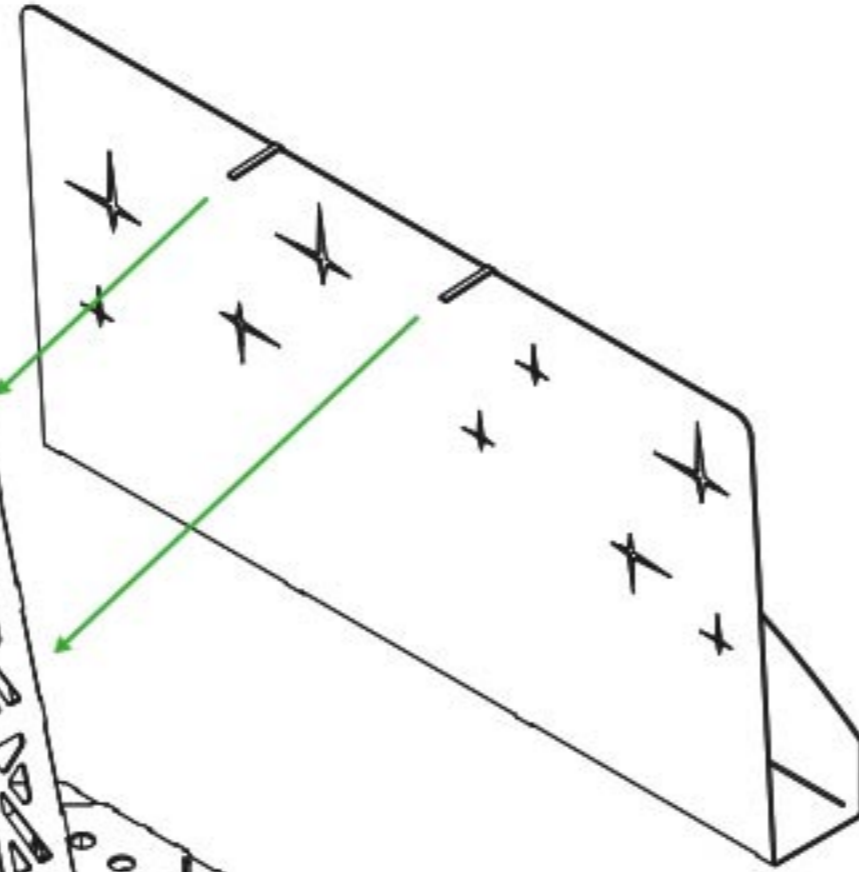
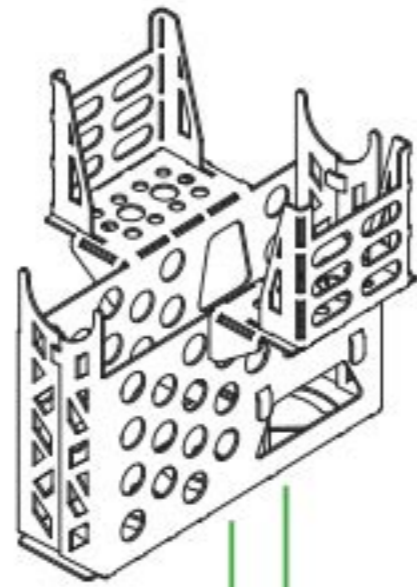
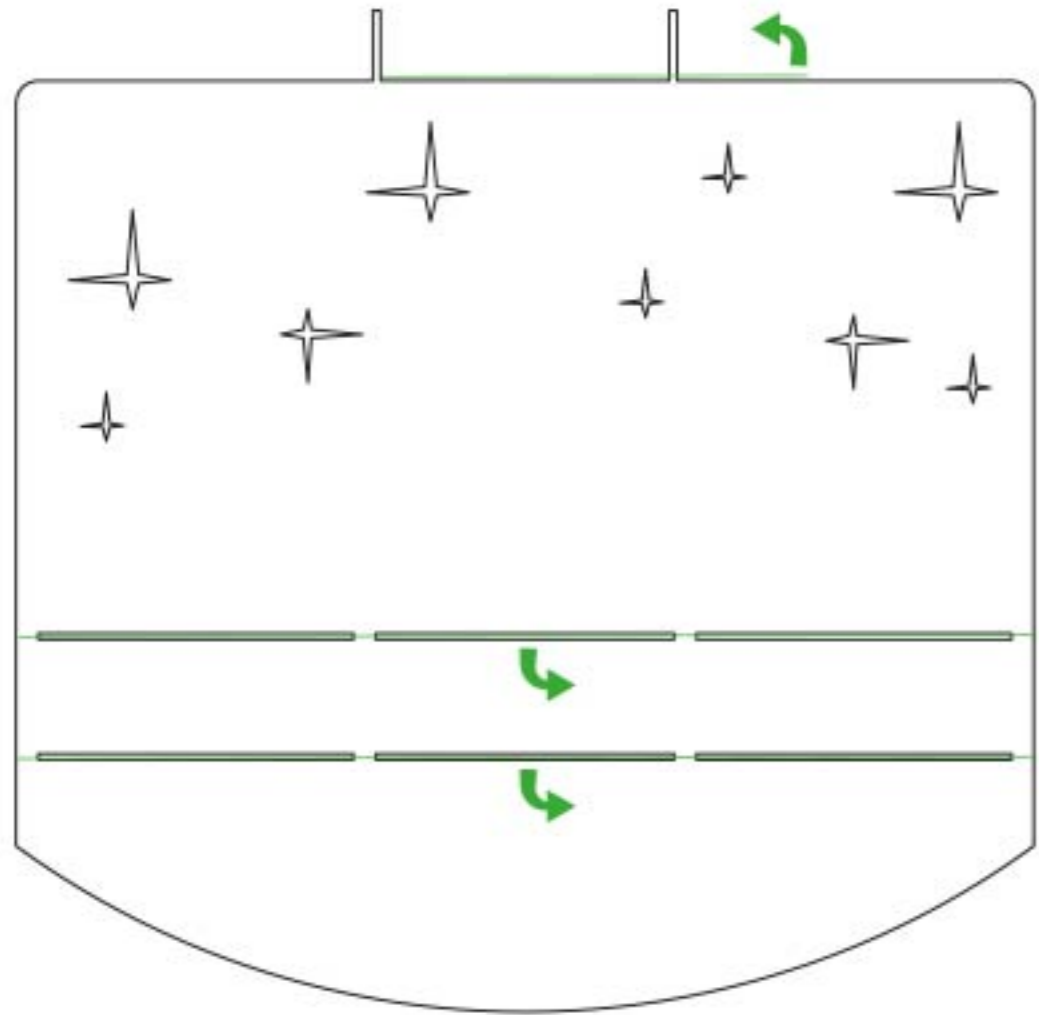

Assembly step 27  
 36ipka krok 27  
 Montaż krok 27  
 Assemblea passo 27  
 Montage schritt 27  
 Assemblée étape 27  
 Montaje paso 27  
 Etapa de montagem 27  
 Сборка шаг 27  
 集会 步骤27  
 조립 단계 27  
 組み立て手順 27  
 خطوة التجميع 27  
 שלב הרכבה 27

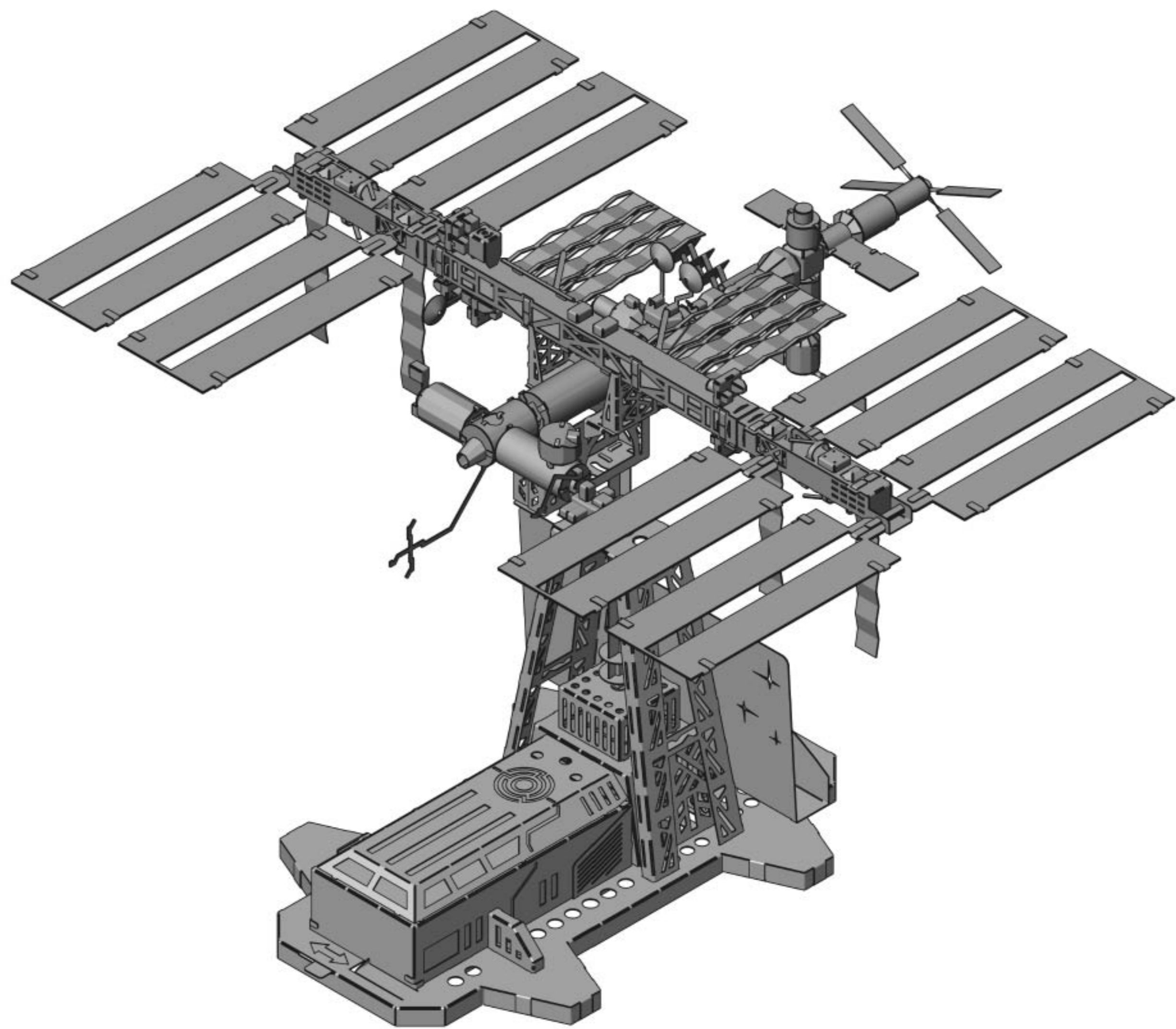
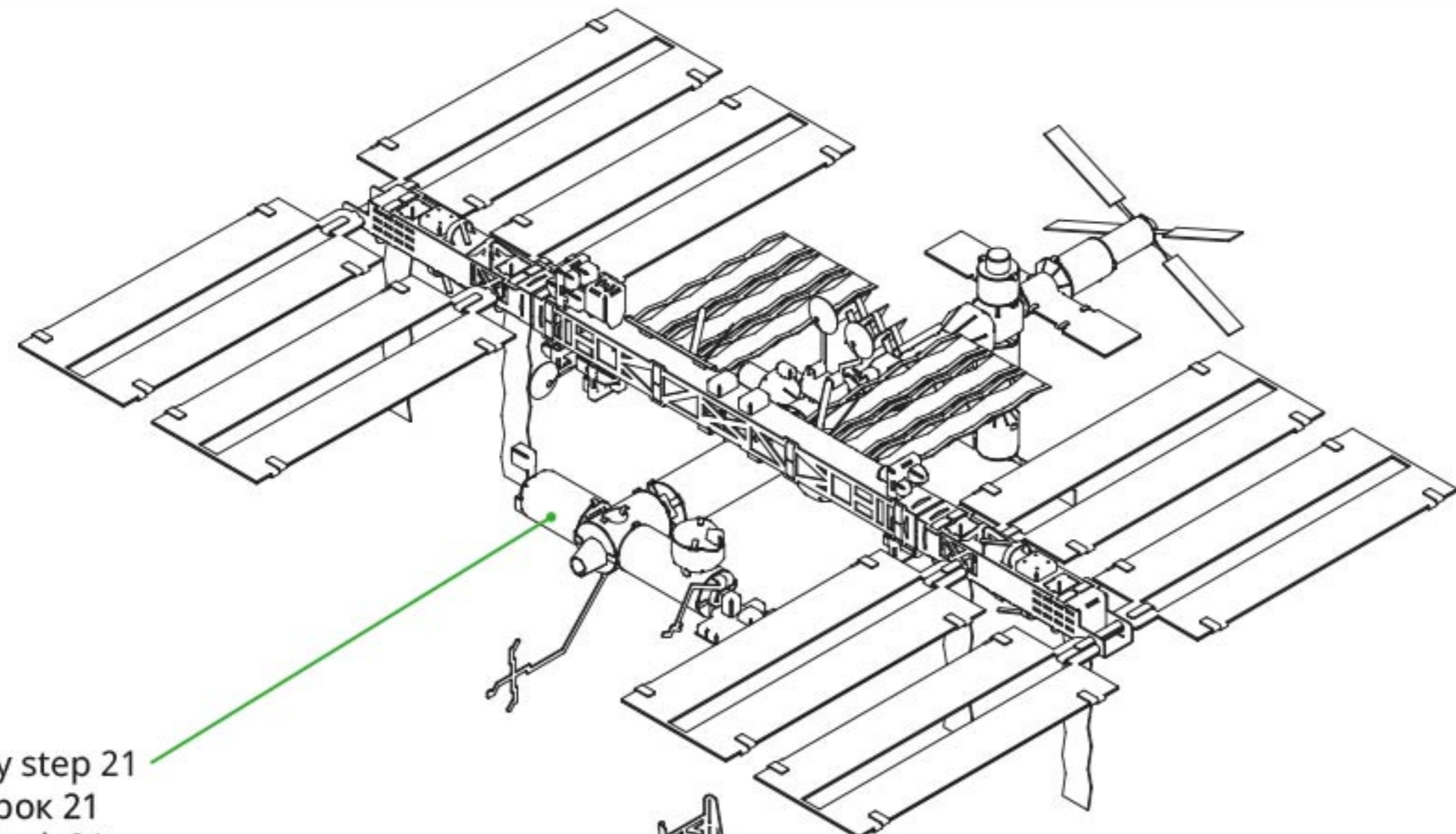

Assembly step 21  
36ipka krok 21  
Montaż krok 21  
Assemblea passo 21  
Montage schritt 21  
Assemblée étape 21  
Montaje paso 21  
Etapas de montagem 21  
Сборка шаг 21  
集会 步骤21  
조립 단계 21  
組み立て手順 21  
خطوة التجميع 21  
שלב הרכבה 21

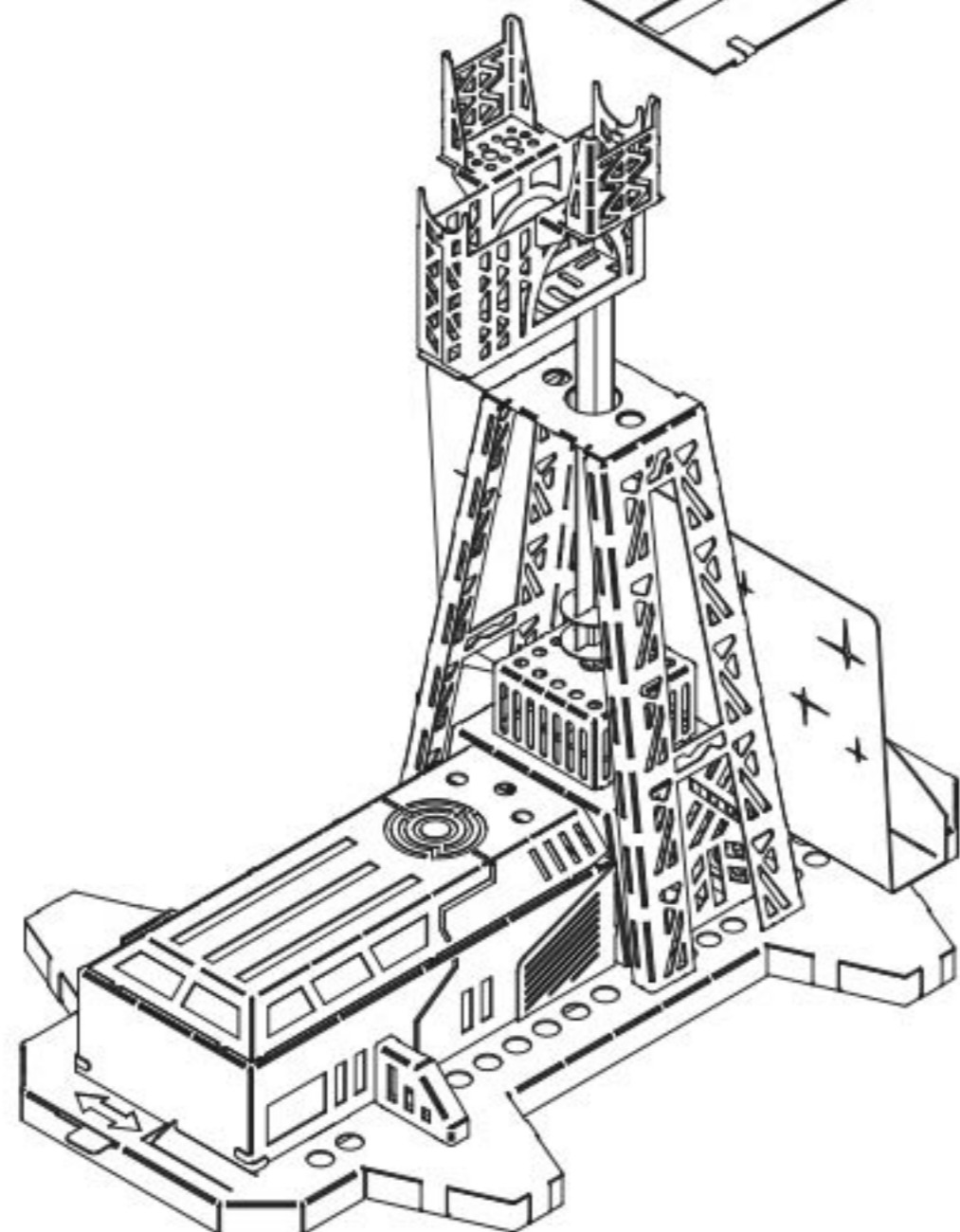

BATTERIES CHANGING / ЗМІНА БАТАРЕЙОК / WYMIANA BATERII / SOSTITUZIONE DELLE BATTERIE  
BATTERIEWECHSEL / CHANGEMENT DE PILES / CAMBIO DE PILAS / TROCA DE BATERIAS / ЗАМЕНА БАТАРЕЕК  
更換電池 / 배터리 교체 / 電池交換 / تغيير البطاريات / באטעריז טשאַנגינג /

Press down  
Натиснути  
Naciśnij w dół  
Premere  
Niederdrücken  
Appuyer  
Apretar  
Pressione para baixo  
Нажать  
按下  
아래로 누르기  
押す  
اضغط لأسفل  
דחוק אראָפּ

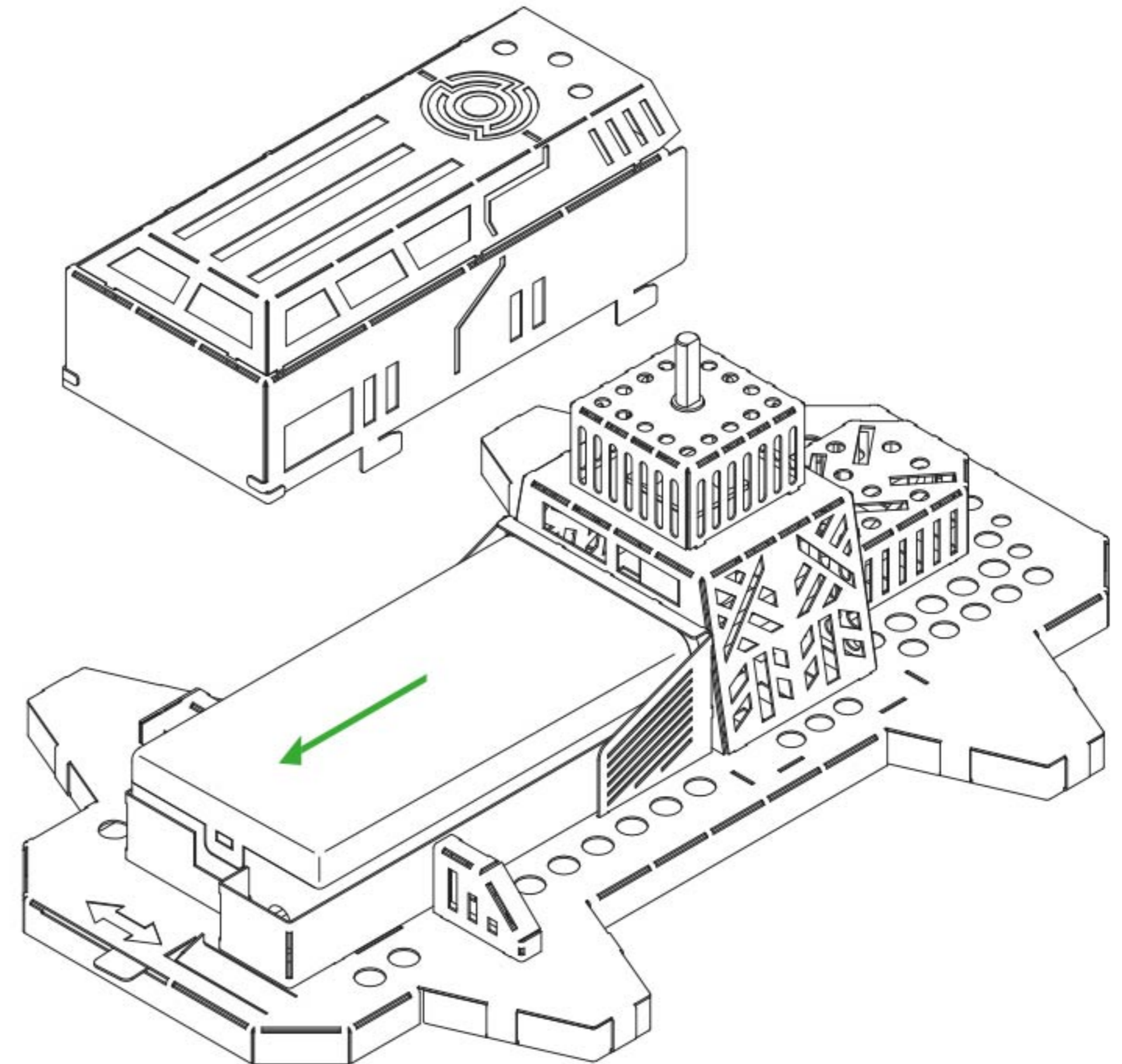
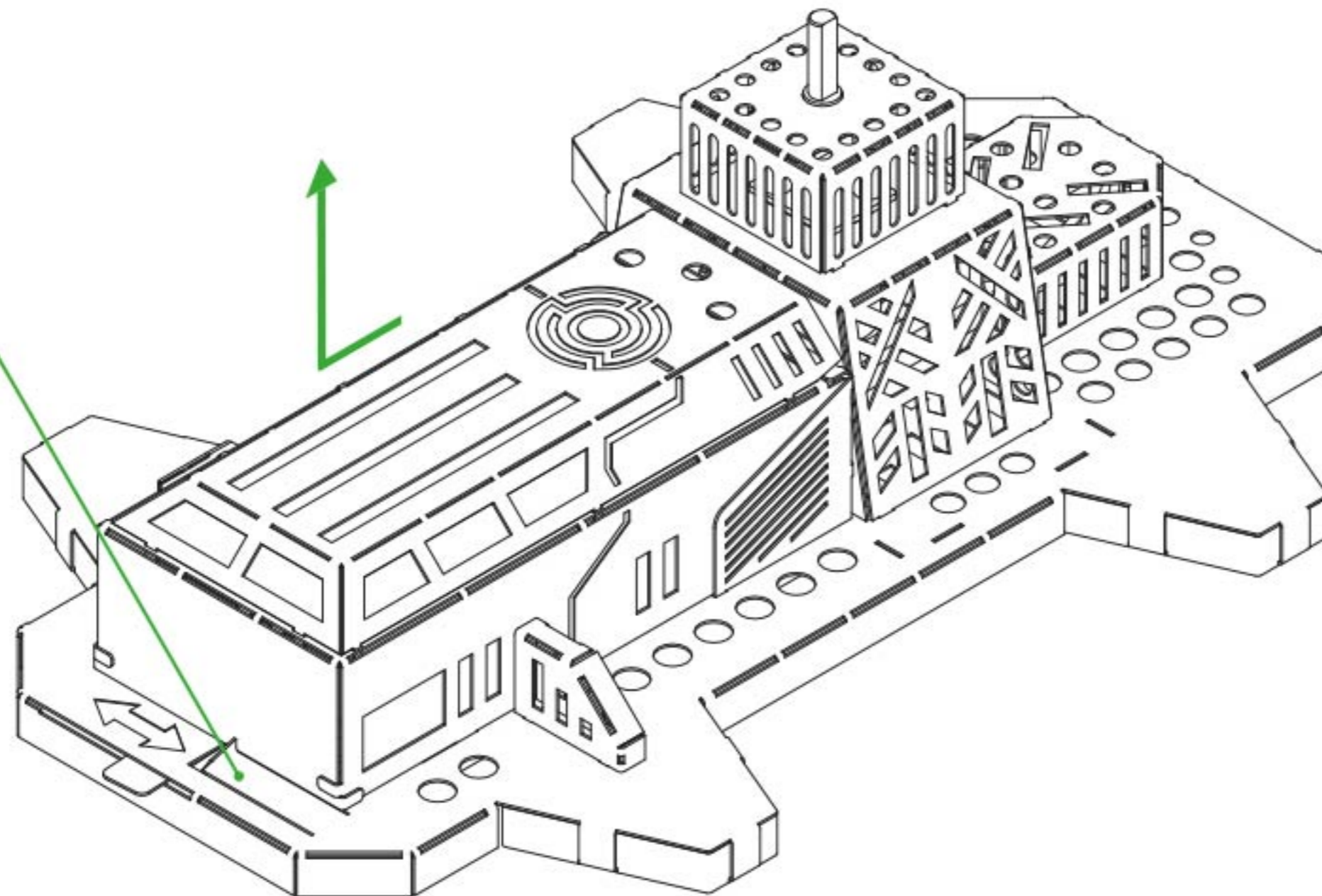

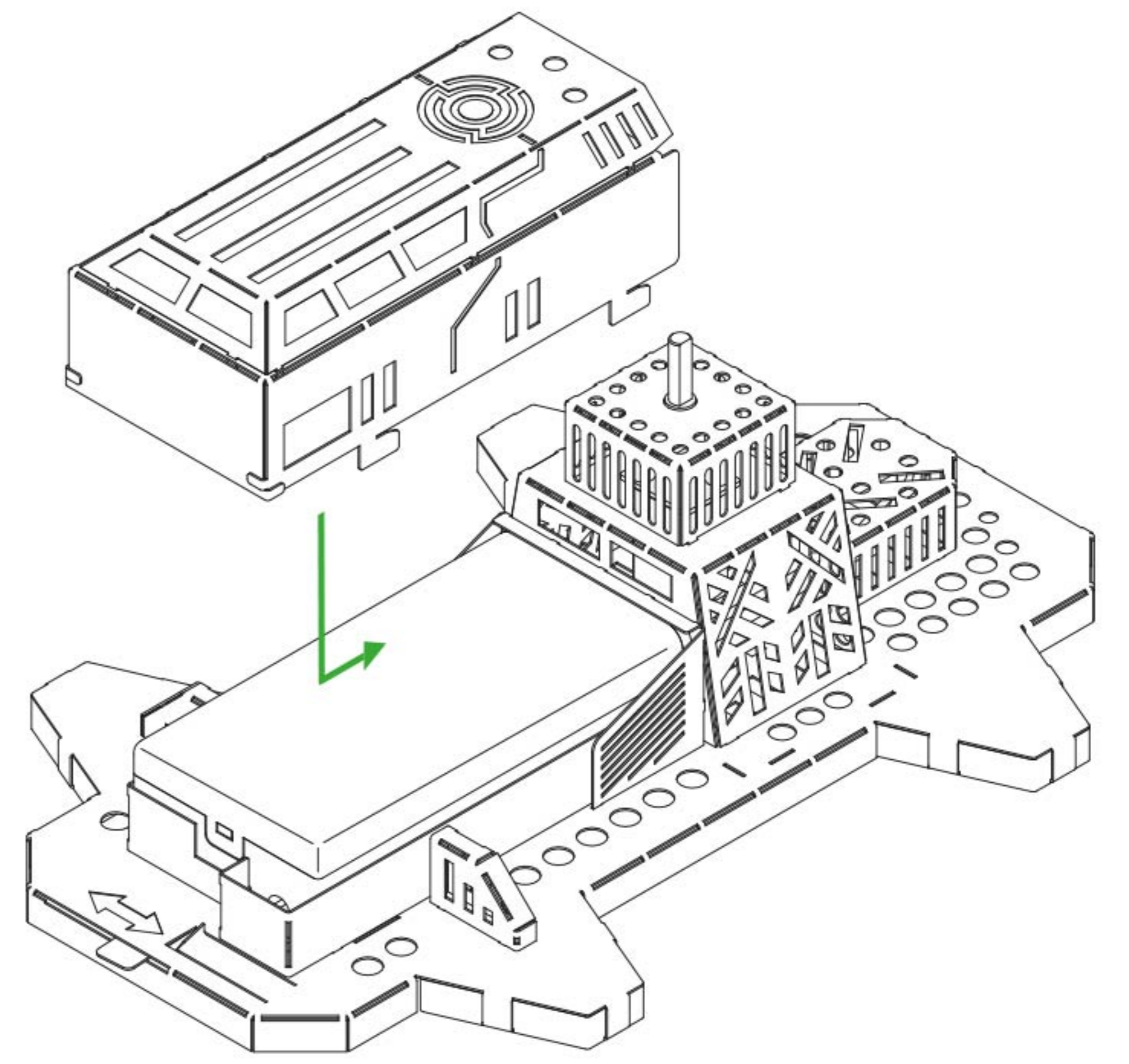
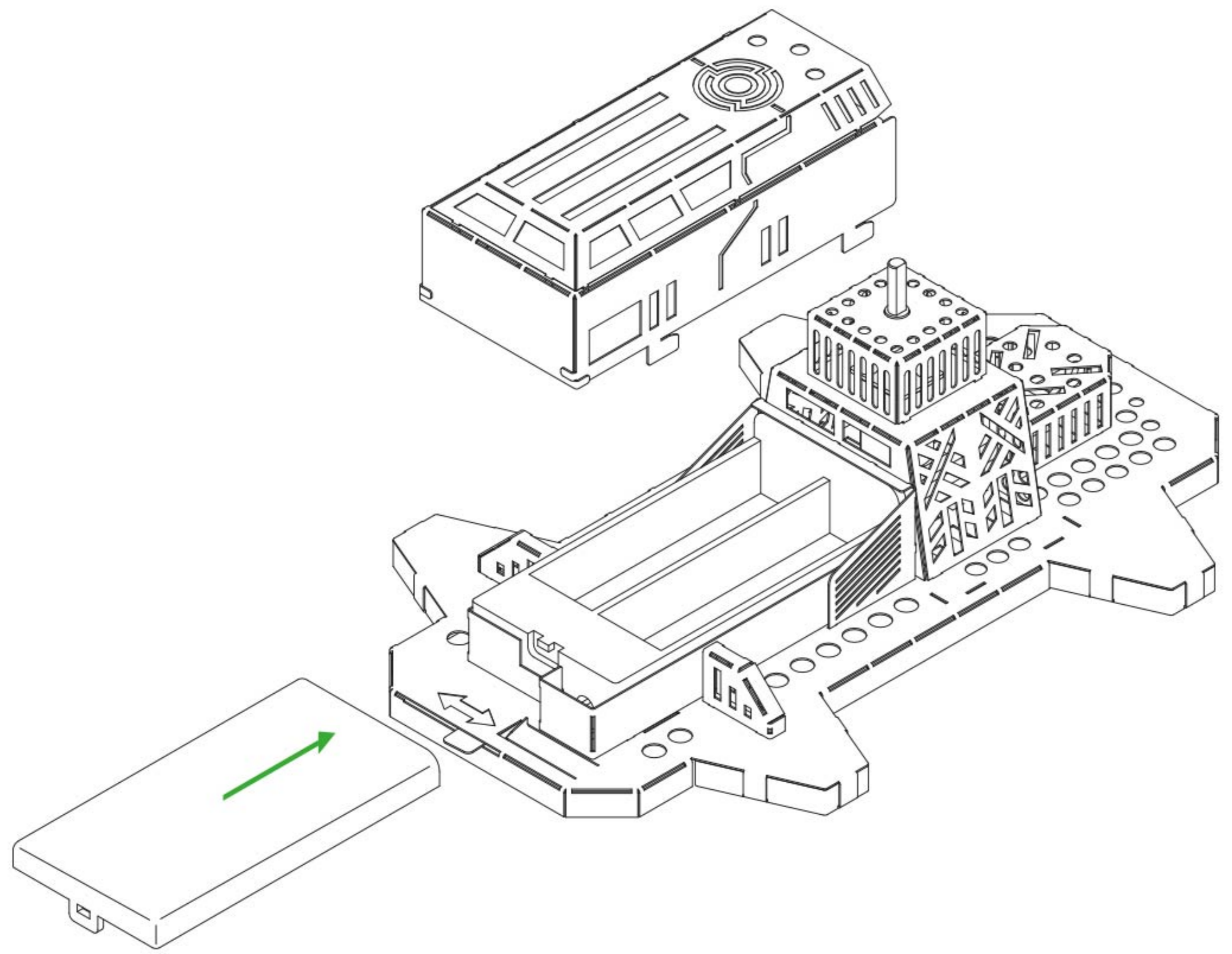



Model name:

# ASTRONAUTS LODGE

The International Space Station (ISS) is a modular space station (habitable artificial satellite) in low Earth orbit. The ownership and use of the space station is established by intergovernmental treaties and agreements. The station serves as a microgravity and space environment research laboratory in which scientific research is conducted in astrobiology, astronomy, meteorology, physics, and other fields. The ISS is suited for testing the spacecraft systems and equipment required for possible future long-duration missions to the Moon and Mars. The assembly of the ISS, a major endeavour in space architecture, began in November 1998. Russian modules launched and docked robotically, with the exception of Rassvet. All other modules were delivered by the Space Shuttle.

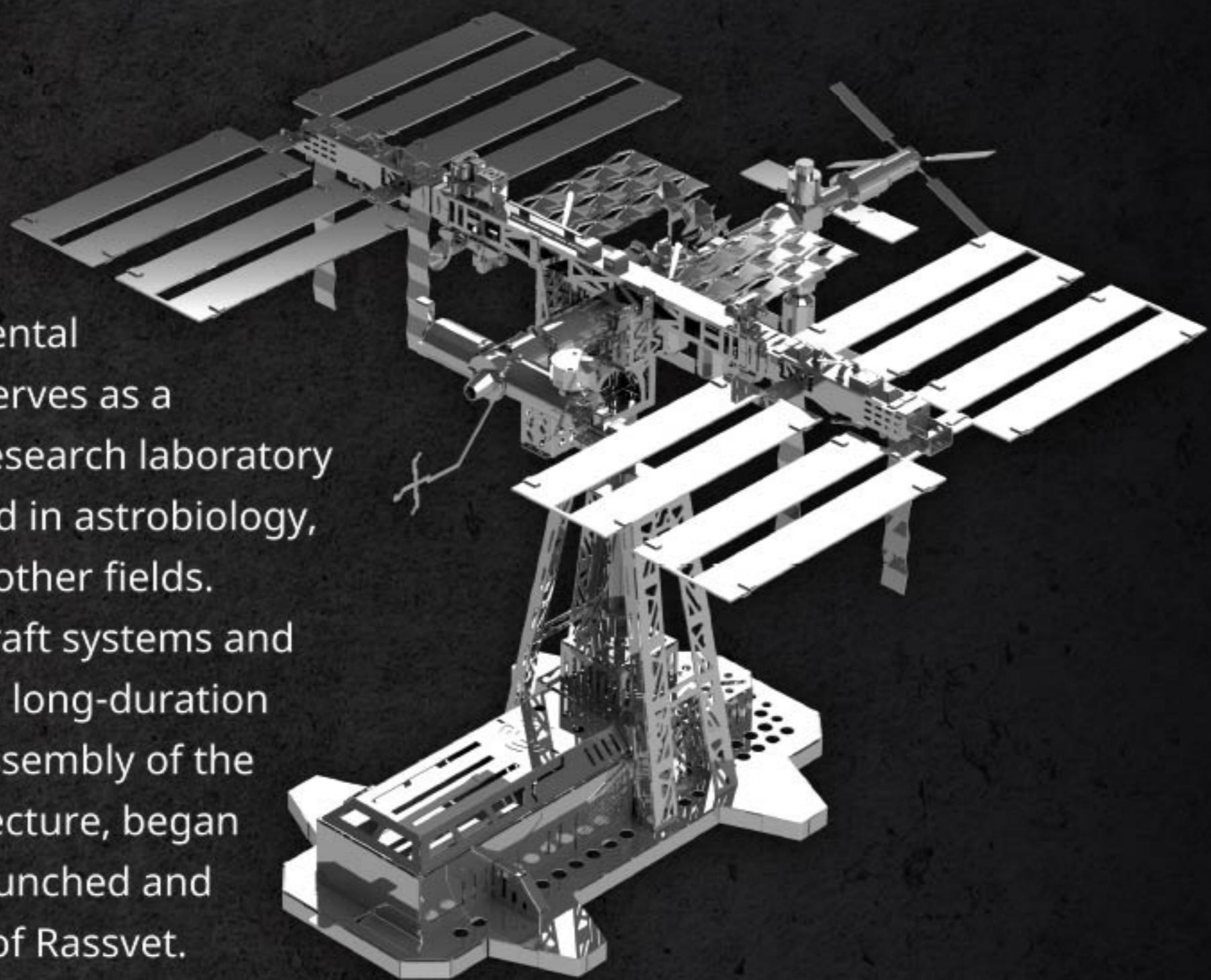

Product number: SKU017

Product material: Stainless steel

Number of metal sheets: 5 pcs

Finish product size: L9.05" ×W7.48" ×H8.66" (L23,4cm ×W19,8cm ×H22,9cm)



**WARNING!**

The product contains small and/or sharp parts. Not suitable for children under 3 years of age.

In order to avoid possible injury from sharp edges, please carefully discard the metal sheet after parts have been removed. This product is not a toy. Keep out of reach of children.

Conforms to CPSIA and CE standards. The product complies with the requirements of EN 71-1,2,3; ASTM F963, REACH, AS/NZS 8124, GB 6675



Difficulty level

No expiration date

MODEL  
BUILDING  
KIT

@hobbadd.cn

霍布德



Designed in Ukraine



Made in China

Collect the Best

**Includes:** steel sheets, pliers, file, gloves, polishing cloth, user's guide, electric motor and battery box (AA batteries are not included).

ALL RIGHTS RESERVED  
© Metal-Time Inc., USA

www.metal-time.com  
info@metal-time.com