

Installation Instructions For Lingenfelter LNC-002 Launch Control Module Adjustable RPM Limiter & Timing Retard Controller For GM LSx Series Engines

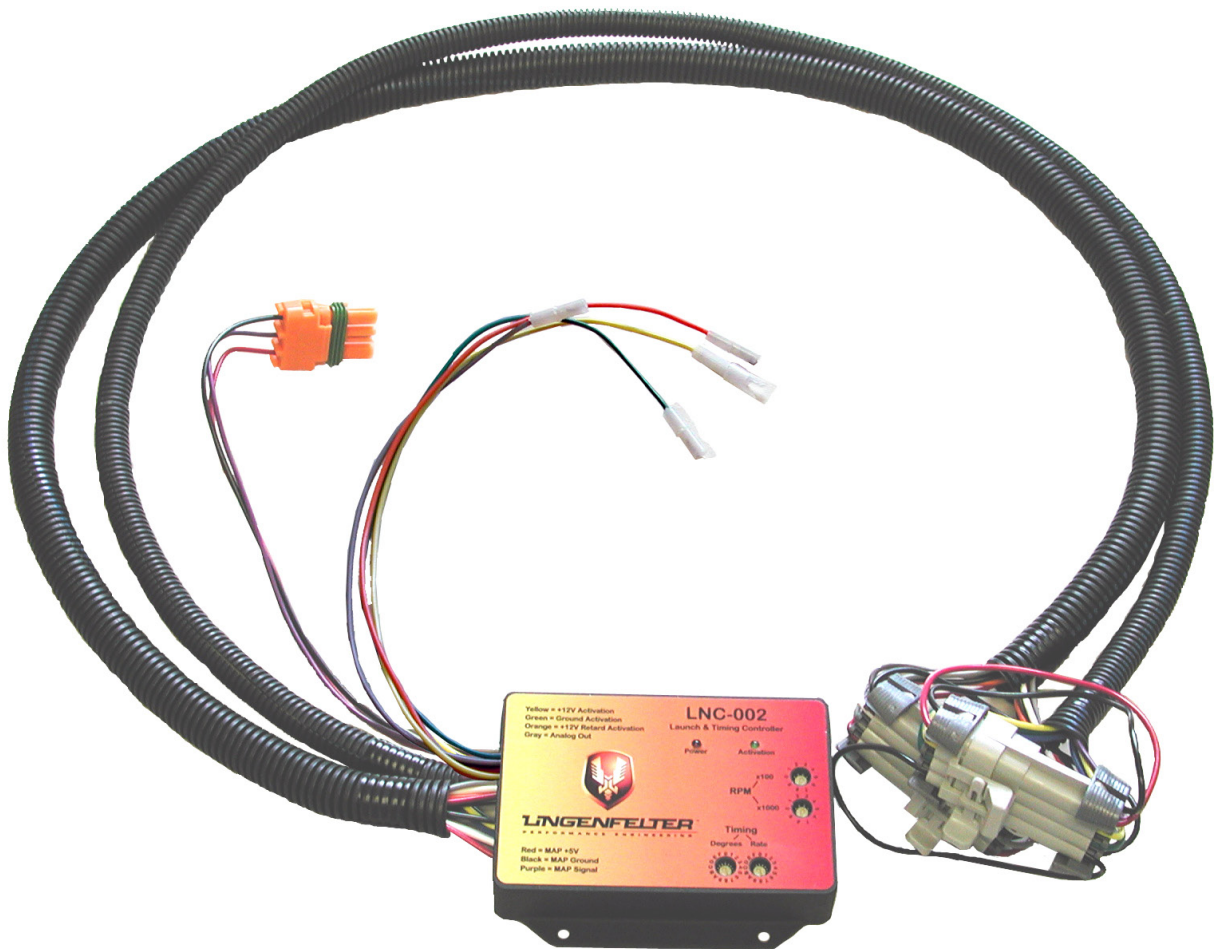

PN: L460095297

1557 Winchester Road
Decatur, Indiana 46733
260 724 2552 phone
260 724 8761 fax
www.lingenfelter.com

LINGENFELTER

PERFORMANCE ENGINEERING

Parts List

#	Part number	Description
1	LNC-002	LPE Launch Controller
1		72" trigger wire harness (<i>part of PN LNC-002</i>)
2		hook & loop tape, 3.5" length
4	AV16037	self-tapping screw
1	L450080000	Transient voltage suppression (TVS) diode kit
1	L920010000	LPE decal
1		instructions

Optional Items

• 3 bar MAP sensor	12223861
• Additional transient voltage suppression (TVS) diode	L450080000
• TPS and clutch switch	NO-00-6102
• MPH activated switch	L460050000
• LED for indicator light	
• Red 12 vdc LED with 30 cm leads	L450030000
• Green 12 vdc LED with 30 cm leads	L450040000
• Sealed 40 amp heavy duty relay kit	L450100000
• Red LED lighted paddle toggle switch, 20 amp	DC-7600500

Specifications:

- Custom molded high temperature glass filled Nylon 6 enclosure with direct access to the controller settings without requiring removal of a cover or access panel.
- 40 MHz 16-bit automotive qualified processor with eight channel Enhanced Time Module.
- Each coil drive circuit has a dedicated timer to keep the timing accurate over the full RPM range.
- Independent coil drive provides Sequential Ignition Kill when RPM limiting is active.
- Reverse battery protection.
- Both of the activation inputs have active clamps and optical isolation to suppress electrical noise from external solenoids (such as trans brake and line lock).
- Digital filter provided in software to further isolate electrical noise on the activation inputs.
- Separate RPM x100, RPM x1000, Degrees and Rate switches for easier setting adjustments.
- RPM limiter activation point can be adjusted from 1500 to 9,900 RPM in 100 RPM increments.
- Both **Ground Activation** and **+12 Volt Activation** inputs are provided for RPM limit activation.
- Timing retard capability with up to 15 degrees of timing retard authority.
- Dedicated timing retard trigger input wire (for nitrous activation or other timing retard activation).
- GM 3 bar manifold air pressure (MAP) sensor connector for boost based timing retard function.
- Analog voltage output wire for sending timing retard information to data acquisition systems (EFILive, HPTuners, DashDAQ, etc.)
- True plug-and-play coil pack connection design for ease of installation and removal.
- Fully encapsulated (potted) construction for added durability.
- 90 day warranty (from date of purchase).

LNC-002 description:

Sometimes referred to as a 2-step or launch controller, the LNC-002 adjustable RPM limiter and timing retard controller can be used to provide consistent launch RPM off the line in drag racing and other standing start racing applications. In turbocharged applications the LNC-002 can also be used to retard the timing in order to build more boost at the line.

The LNC-002 can also be used as an adjustable individual cylinder RPM limiter, providing reliable and fast acting spark based engine RPM limit control. This is especially useful in vehicles that have auxiliary fuel control systems where it is not possible to make sure that both the factory ECM/PCM and the auxiliary systems both turn off fuel at exactly the same time. If the two don't completely cut fuel at the same time you will run lean when the one system cuts off the injectors (but not the other), risking severe engine damage.

The Timing Retard capabilities of the LNC-002 can be used to retard timing by up to 15 degrees. For nitrous oxide applications the timing retard can be activated using the dedicated timing retard activation input to the LNC-002. In turbocharged and supercharged engines the amount of retard can be controlled by the boost level using the 3 bar MAP sensor input. The LNC-002 can also be used to retard the timing at the line to build boost in turbocharged vehicle applications (with or without the launch control RPM active). The Timing Retard function can be used by itself or while the launch control RPM limit function is active.

Please note - although launch controllers like the LNC-002 are often referred to as 2-step controllers, they are not true 2-step controllers. A 2-step has a high and a low RPM limit function with a switch of some type enabling one setting or the other. The LNC-002 only has one RPM limit setting so if you are using the LNC-002 as a launch control RPM limiter, you will need to use the factory ECM/PCM as the engine maximum RPM limiter (engine speed governor).

WARNINGS:

The RPM limiter function of the LNC-002 acts by disabling spark to individual cylinders and not fuel like most production RPM limiters so the 2-Step/Launch Control function is not meant for use on the street or for use on cars equipped with catalytic converters. The 2-Step/Launch Control function of the LNC-002 is only for use at the race track on race vehicles not equipped with catalyts. Failure to follow these precautions can result in premature catalyst failure.

DO NOT operate the engine with the LNC-002 RPM limit active for extended periods of time. Due to the raw fuel in the exhaust when the RPM limit is active, a risk of backfiring exists if you do so.

DO NOT place in direct exposure to exhaust manifolds, turbocharger turbine housings or other underhood items that are high temperature heat sources (radiated heat sources). The warranty does not cover damage due to melted enclosures or wiring due to improper installation.

Do NOT submerge Controller in liquid or directly wash unit with liquid of any type! The switches on the LNC-002 are sealed but are NOT rated for high pressure wash, use caution if power washing near the LNC-002 controller

LINGENFELTER

PERFORMANCE ENGINEERING

Switches and indicator lights:

Red (Power) LED:

- Comes on solid on start-up (power on)
- When active RPM is reached, red LED will blink (even if activation wire is not triggered)

Green (Activation) LED:

- slow blink rate (4 Hz) for Launch Activation only
- medium blink rate (8 Hz) for Retard Activation only
- fast blink rate (16 Hz) for both launch and retard inputs on



Settings:

- Controlled by two (2) ten position switches (**RPM**) and two (2) sixteen position switches (**Timing**)
 - Two (2) ten position switches for selecting hundreds of RPM (x100) and thousands of RPM (x1000)
 - Two (2) sixteen position switches for selecting retard **Degrees** and timing retard **Rate**

Notes:

- The LNC-002 RPM limiter function will not trigger at RPM levels below 1500 RPM
- The LNC-002 timing retard function will not retard timing below 1000 RPM
- **Changes to the switch point settings (RPM, Degrees, Rate) must be done with the ignition off**
 - The switch positions are only read on start up

Example settings:

- 1900 RPM activation point for launch control
 - Upper (x100) RPM switch on position 9
 - Lower (x1000) RPM switch on position 1
- 6900 RPM activation point for RPM limiter
 - Upper (x100) RPM switch on position 9
 - Lower (x1000) RPM switch on position 6

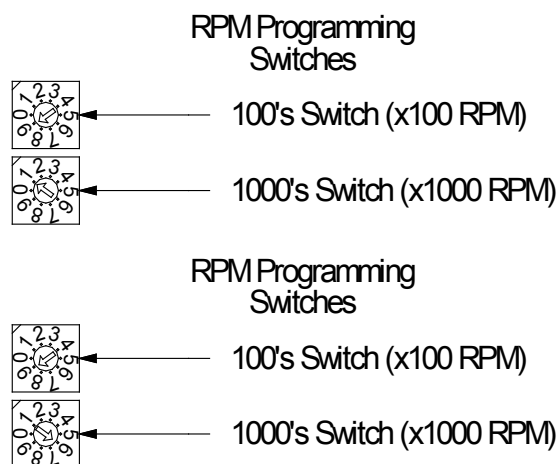

Installation:

- Make sure the ignition is off before beginning installation.
- You can mount the LNC-002 using the supplied hook and loop tape or the supplied self tapping screws.
- Do NOT mount the LNC-002 directly on top of the engine or near the exhaust manifolds due to heat concerns.
- Do NOT mount the LNC-002 in the line of site of high temperature objects such as exhaust manifolds, turbine housings etc. If needed, put a heat shield in between the heat source and the module to protect the plastic case.
- Do NOT install within 6" of nitrous solenoids or other devices with strong magnetic fields.
- If you have relocated coil packs, do not run the high voltage spark plug wires alongside the low voltage coil pack wires. Keep the wires as far apart as possible and, if they do have to intersect, have them intersect at right angles.
- Disconnect the pack connectors on each side of the engine and then plug the LNC-002 wiring harnesses in between on each side. It does not matter which bank of cylinders each side of the LNC-002 harness connects to.
- The only wiring that is required is for the trigger wire(s) depending on how you want to enable the device. See pages 9 to 14 for specific wiring diagrams. While we have tried to cover most configurations, many different possible wiring methods exist, too many for us to list them all. Check some of the GM, LS1, Corvette, GTO and other forums for discussions on other wiring methods. The possible trigger/activation connection methods are:
 - ground activation wire (green) - connect this wire to a source that supplies a ground path when you want the LNC-002 to become active
 - +12 volt activation wire (yellow) - connect this wire to a source that supplies +12 volts when you want the LNC-002 to become active (i.e. brake light switch, line-lock solenoid)
 - switch connected in between the ground activation wire and the +12 volt activation wire (green wire connected to yellow wire through a switch, usually a momentary switch)
 - ground activation wire connected to +12 volt activation wire (green connected to yellow) for standard RPM limiter operation (LNC-002 always active)
- Set the desired RPM switch activation point using the two ten position rotary switches for the 1000 RPM increment (x1000) and the 100 RPM increment (x100).
- If you are using the timing retard feature, either connect a 12 vdc trigger wire to the orange Retard Activation wire or, if you will be using boost based timing retard, connect a GM 3 bar MAP sensor to the MAP sensor connector.

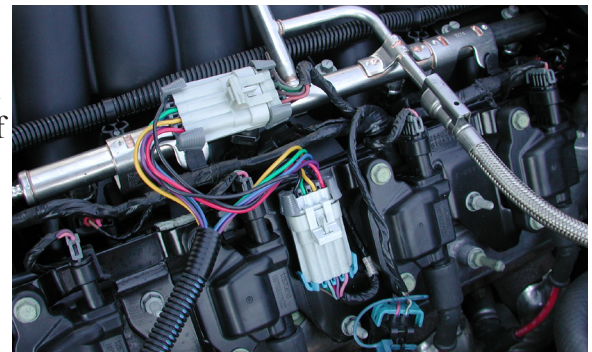

LINGENFELTER

PERFORMANCE ENGINEERING

Launch Control/2-Step Features

The independent coil drive of the LNC-002 provides sequential ignition kill when RPM limiting is active. The desired RPM limiting is set as shown on page 3. The activation for the Launch Control/2-Step function is controlled by the ground (green) or +12 volt (yellow) activation wires.

If you are triggering off of the clutch switch, the 2-step will trigger each time you depress the clutch pedal. This can be used to provide an ignition cut/torque cut on each gear change to potentially allow for faster shifts/faster clutch engagement.

If you do not want the 2-step to trigger when you engage the clutch pedal once you are moving then you will need to install a momentary switch or use the Lingenfelter MPH activated switch. With the MPH activated switch you can set at what MPH you want the 2-Step activation to be disabled.

Timing Retard Features

Up to 15 degrees of timing retard can be applied. The amount of retard is adjusted with the **Degrees** switch and the retard rate is adjusted with the **Rate** switch. The timing retard function can be triggered two ways:

- Retard activation wire - orange wire to be connected to a 12 volt DC activation trigger switch
- MAP sensor input connection - to be connected to a GM 3 bar MAP sensor

For either trigger method, ignition retard is only active when the engine RPM is above 1,000 RPM. MAP sensor based retard is only active if a MAP sensor is connected to the MAP sensor input. If the orange wire is connected while a MAP sensor is also connected then the timing retard will go to the maximum retard value set with the **Degrees** switch. The Retard may be activated while the RPM Limiter is active.

Setting The Spark Timing Retard Value

The spark retard amount is set with the **Degrees** switch on the box. The settings are as followings:

Position	Degrees
0.....	0
1.....	1
2.....	2
3.....	3
4.....	4
5.....	5
6.....	6
7.....	7
8.....	8
9.....	9
A.....	10
B.....	11
C.....	12
D.....	13
E.....	14
F.....	15



Setting The Spark Retard Rate

The spark retard rate is set with the **Rate** switch on the box. The settings are as follows:

- **Retard build time settings 0 – 7.** Hold and Wait retard, must power unit down after activation to reset build timer. Retard goes on/off with activation but build timer does NOT reset. Good for drag strip with nitrous.

Position	Rate
0.....	Retard is immediate.
1.....	0.2 second (retard build time)
2.....	0.4 second
3.....	0.6 second
4.....	0.8 second
5.....	1.0 second
6.....	2.0 seconds
7.....	3.0 seconds

- **Retard build time settings 8 – F.** Retard and build timer will reset any time the activation signal is removed and re-applied.

Position	Rate
8.....	0.2 second (retard build time)
9.....	0.4 second
A.....	0.6 second
B.....	0.8 second
C.....	1.0 second
D.....	2.0 seconds
E.....	2.5 seconds
F.....	3.0 seconds

Retard Rate settings when using MAP sensor input:

Position	Rate
0.....	0.2 degrees/psi
1.....	0.4 degrees/psi
2.....	0.5 degree/psi
3.....	0.6 degree/psi
4.....	0.8 degree/psi
5.....	1.0 degree/psi
6.....	1.2 degree/psi
7.....	1.4 degree/psi
8.....	1.6 degree/psi
9.....	1.8 degree/psi
A.....	2.0 degree/psi
B.....	2.2 degree/psi
C.....	2.4 degree/psi
D.....	2.6 degree/psi
E.....	2.8 degree/psi
F.....	3.0 degree/psi

The retard **Rate** setting controls how quickly the controller goes to the amount of timing retard set with the **Degrees** switch. For example, if you have the Degrees switch set to 10 degrees and you have the Rate switch set to 1 second, after 0.5 seconds you will have roughly 5 degrees of retard and it will take one second to build up to the full 10 degrees of retard.

When using the MAP sensor input, the Rate setting controls how many degrees of retard per pound (psi) of boost and the Degrees setting controls the maximum number of degrees retard to allow. For example, if you have the controller set to 10 degrees with the **Degrees** switch (position A) and the **Rate** switch set to 3 degrees per pound of boost (position F), then at 1 psi of boost you would have 3 degrees of retard, at 2 psi of boost you would have 6 degrees of retard, at 3 psi you would have 9 degrees of retard but at 4 psi you would only have 10 degrees of retard because you have the maximum setting with the Degree switch set to 10. If you had the **Degrees** switch set to 15 degrees (position F) then at 4 psi of boost you would have 12 degrees of retard.

When using boost based timing retard the orange retard activation input wire will force the retard to the maximum retard level setting on the Degrees switch no matter what the boost level is. This allows you to use the orange trigger wire to retard timing at the line in order to build boost and then still use the boost based timing retard as you go down the track.

Timing retard notes:

- When the LNC-002 is powered up with no MAP Sensor installed it will default to Time Based Retard mode.
- When the LNC-002 is powered up with a MAP Sensor installed it will switch to Boost Retard mode. The “Degrees” switch will still set the Maximum amount of retard allowed. The “Rate” switch will control the degrees of retard applied for each lb of boost applied to the MAP Sensor.

Timing retard analog output

The LNC-002 provides an analog voltage output that indicates the amount of timing retard that is being applied. The gray analog output wire provides a linear 0 to 3 volt DC output with 0 volts indicating 0 degrees of timing retard and 3 volts indicating 15 degrees of timing retard. This voltage value can be logged with EFILive, HPTuners, DashDAQ or other devices to allow you to determine how much timing you really had while going down the track.

Note - because the LNC-002 modifies the ignition timing after the PCM or ECM, the factory computer is not aware of the changed timing so it will not display the modified timing value in a scan tool.

Additional Notes

Important Information regarding spark plug wires and spark plugs:

You must use noise suppression ignition wires and resistor type spark plugs with this Controller. The LNC-002 Controller contains High Frequency Digital Electronics and will NOT function correctly without Noise Suppression Wires!

Nitrous, line-lock, trans-brake and other solenoid usage warning:

LPE has found that these solenoids can cause fly-back voltage levels at times in excess of 600 volts. These voltage levels have the potential to damage sensitive electronics including the LNC-002, the PCM/ECM and other modules in the vehicle. Lingenfelter Performance Engineering has developed a transient voltage suppression (TVS) diode kit (PN L450080000) for use with line-lock solenoids, trans-brake solenoids and other aftermarket automotive solenoids of this type. LPE recommends the use of our noise suppression diode on all vehicles that have a line lock or trans-brake. This kit comes with one TVS diode. If you have a vehicle with multiple solenoids we recommend obtaining additional TVS diodes for those solenoids.

Troubleshooting:

- Intermittent misfire or other erratic vehicle operation.
 - Disconnect the LNC and see if the problem still exists to confirm the problem is related to the LNC. If the problems goes away when you disconnect the LNC from the system, re-install the LNC and re-route the LNC wiring harness away from the spark plug wires and/or ignition coils. Also try mounting the LNC in a different location. If you are using aftermarket spark plug wires, try changing back to the stock spark plug wires or a different brand of spark plug wires. Make sure you are using noise suppression spark plug wires and resistor type spark plugs.

For additional product installation information and technical support, contact LPE or your LPE products distributor. You can also find technical support and usage discussions regarding this product and many other LPE products in our Internet forums:

<http://www.lingenfelter.com/LPEforumfiles>

Example wiring diagrams:

The following pages show examples of how the LNC-002 can be wired in different vehicle applications. Many other possible installation methods exist.

- On manual transmission vehicle applications please note that most GM vehicles have two clutch switches (a cruise control switch at the top of the travel and a neutral safety clutch switch at the bottom of the travel). Make sure you are connecting to the correct one. In testing LPE has found that the upper clutch switch (cruise control switch) has erratic output and causes improper operation of the LNC. The wiring diagrams on the following pages show how to connect to the correct clutch switch. On 2008-2010 Corvettes and 2010 Camaro SS GM has switched to a signal clutch position sensor with a 0-5 volt output. The output of this sensor is actually from high to low. The clutch position sensor will not trigger the LNC directly or most relays and a TPS/clutch switch must be wired in on the vehicles. This switch is available from LPE as part number NO-00-6102.

LINGENFELTER

PERFORMANCE ENGINEERING

1998-2002 F-Body and 1997-2008 Corvette Factory Clutch Switch Diagram

1 - Locate CPP (Clutch Position Switch) and unplug 2-wire connector.

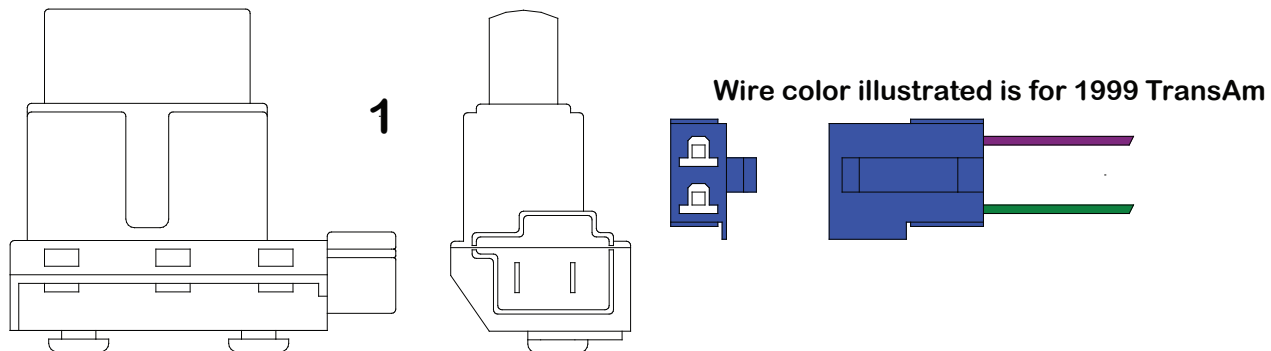

2 - Cut wires approx. 3" back from connector.



3 - Find +12 volt Key On power source and connect to one wire of CPP connector.

4 - Splice two wires onto remaining CPP connector wire and connect one wire to #85 on Relay. The extra wire will be used for LNC-002 Launch Controller activation.

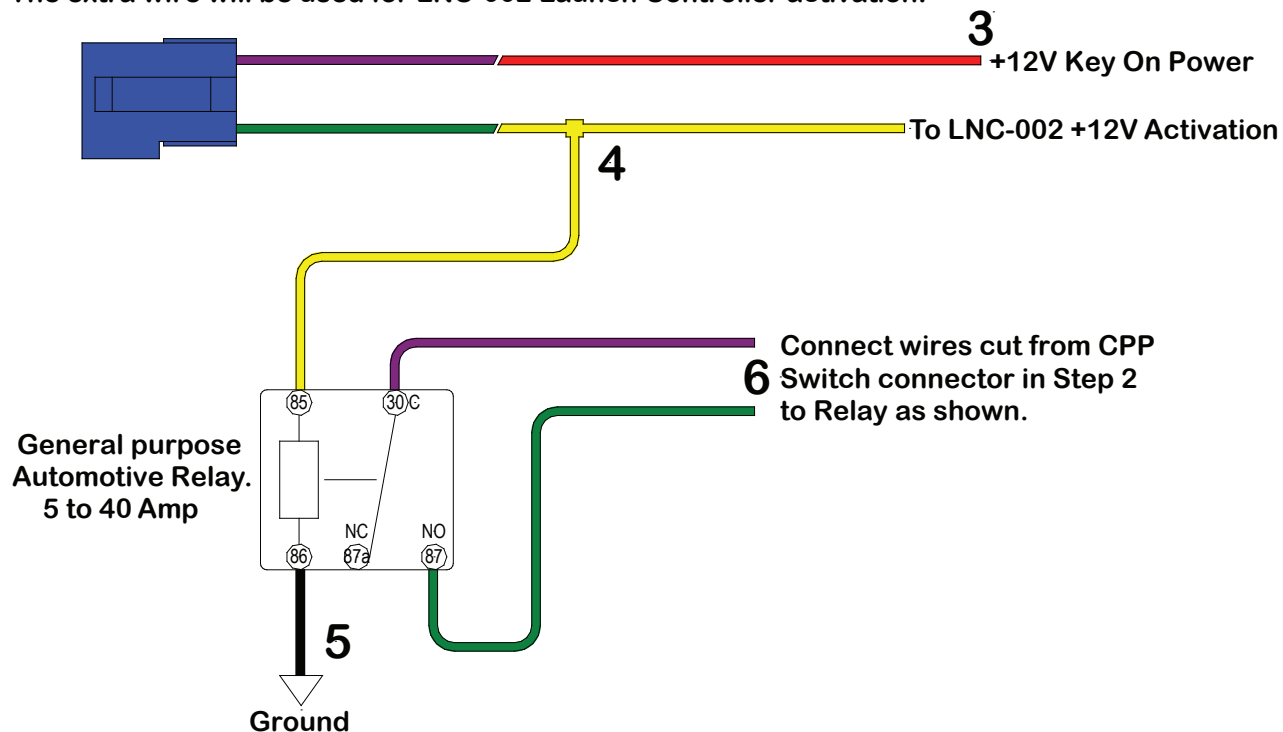

5 - Connect terminal #86 on Relay to Ground.

6 - Connect wires cut from CPP Switch connector to Terminals #30 and #87 as shown. Wire color may vary for model/year.

Manual Transmission with Linelock

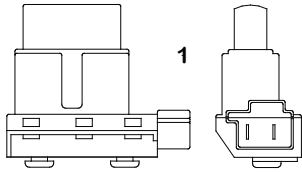

Wire color illustrated is for 1999 TransAm

- 1 - Locate CPP (Clutch Position Switch) and unplug 2-wire connector.
- 2 - Cut wires approx. 3" back from connector.
- 3 - Find +12 volt Key On power source and connect to one wire of CPP connector.
- 4 - Splice two wires onto remaining CPP connector wire and connect one wire to #85 on Relay. The extra wire will be used for LNC-002 Launch Controller activation.
- 5 - Connect terminal #86 on Relay to Ground.
- 6 - Connect wires cut from CPP Switch connector to Terminals #30 and #87 as shown.

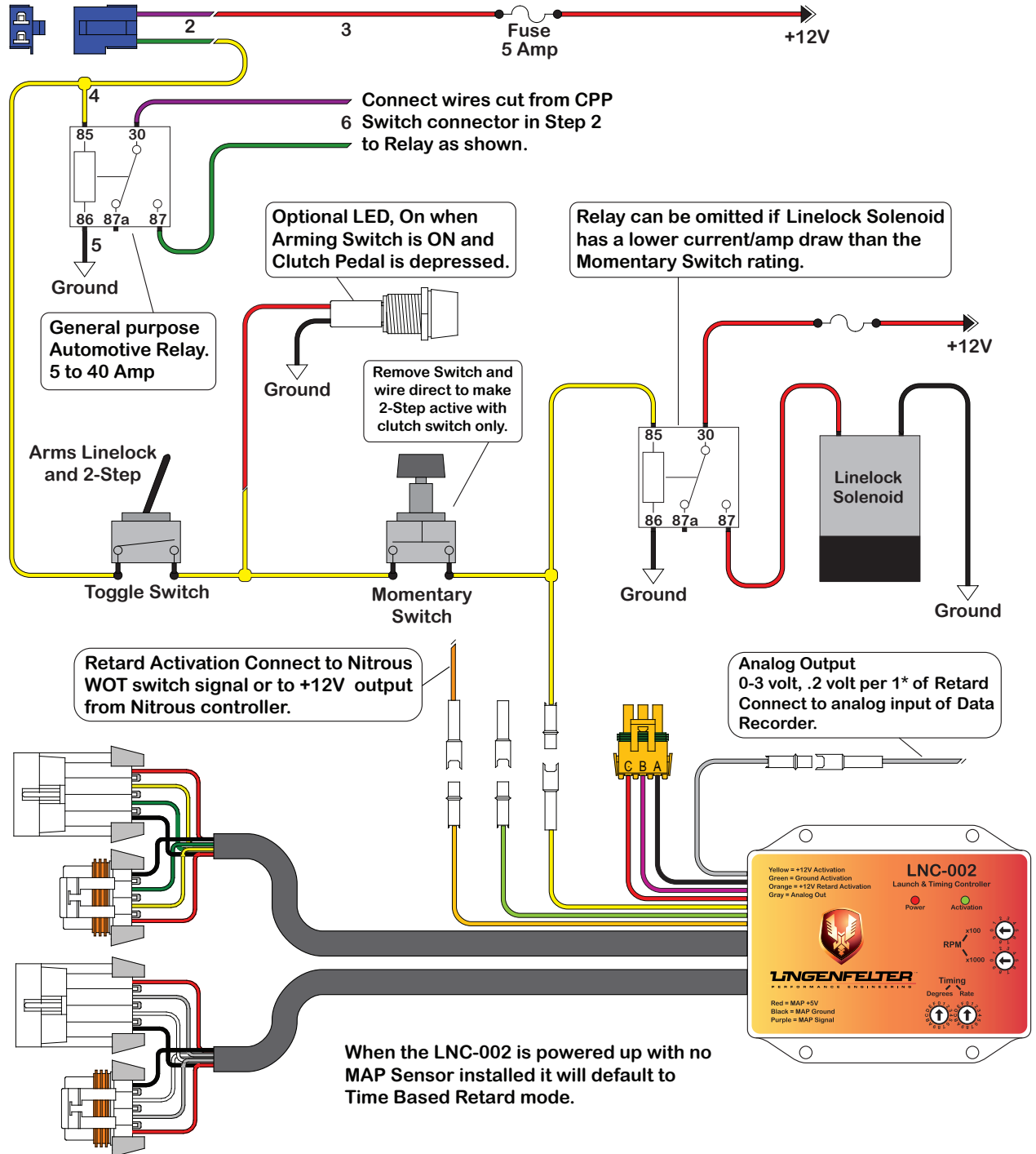

Manual Transmission with Linelock & Nitrous

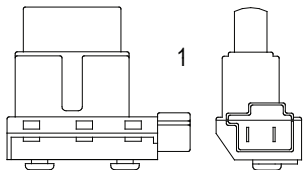

- 1 - Locate CPP (Clutch Position Switch) and unplug 2-wire connector.
- 2 - Cut wires approx. 3" back from connector.
- 3 - Find +12 volt Key On power source and connect to one wire of CPP connector.
- 4 - Splice two wires onto remaining CPP connector wire and connect one wire to #85 on Relay. The extra wire will be used for LNC-002 Launch Controller activation.
- 5 - Connect terminal #86 on Relay to Ground.
- 6 - Connect wires cut from CPP Switch connector to Terminals #30 and #87 as shown.

Wire color illustrated is for 1999 TransAm

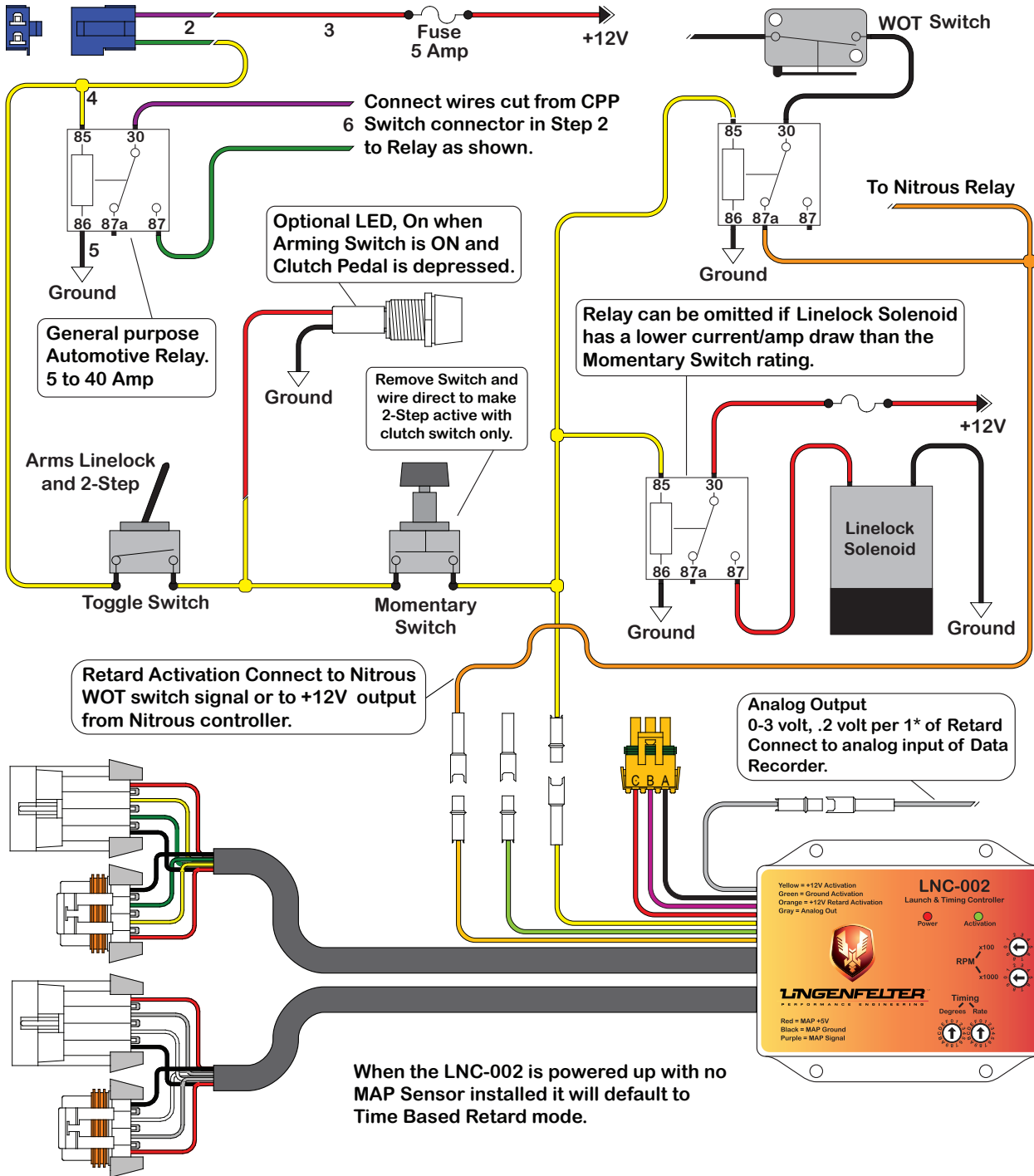

Automatic Transmission with Linelock

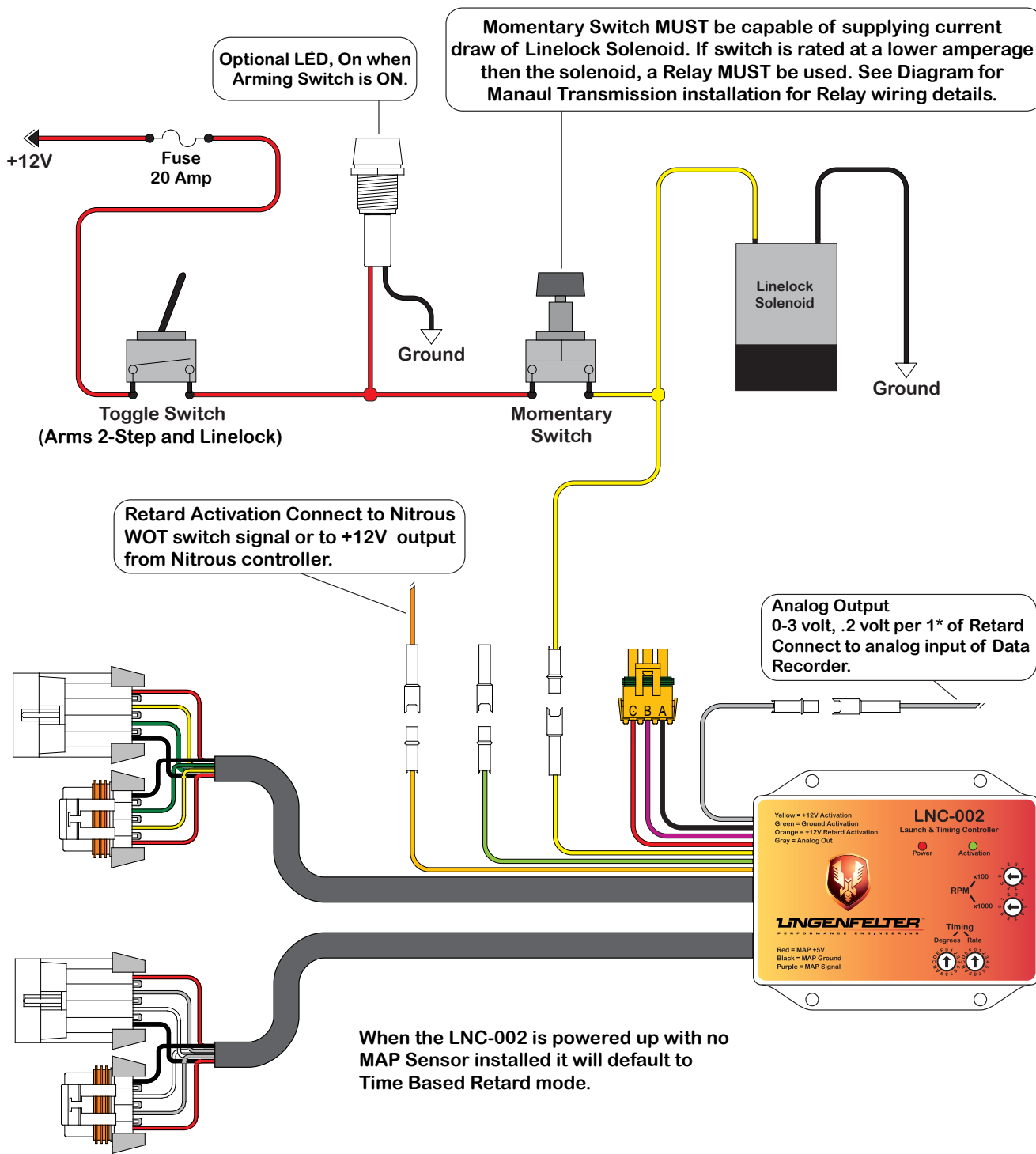

Automatic Transmission with Linelock & Nitrous

The "Nitrous Disable Relay" is used to disconnect the "Wide Open Throttle" switch from the Nitrous Relay. This allows the throttle to go wide open while the Linelock / 2-Step is Active and the Nitrous will remain OFF until the Linelock is released.

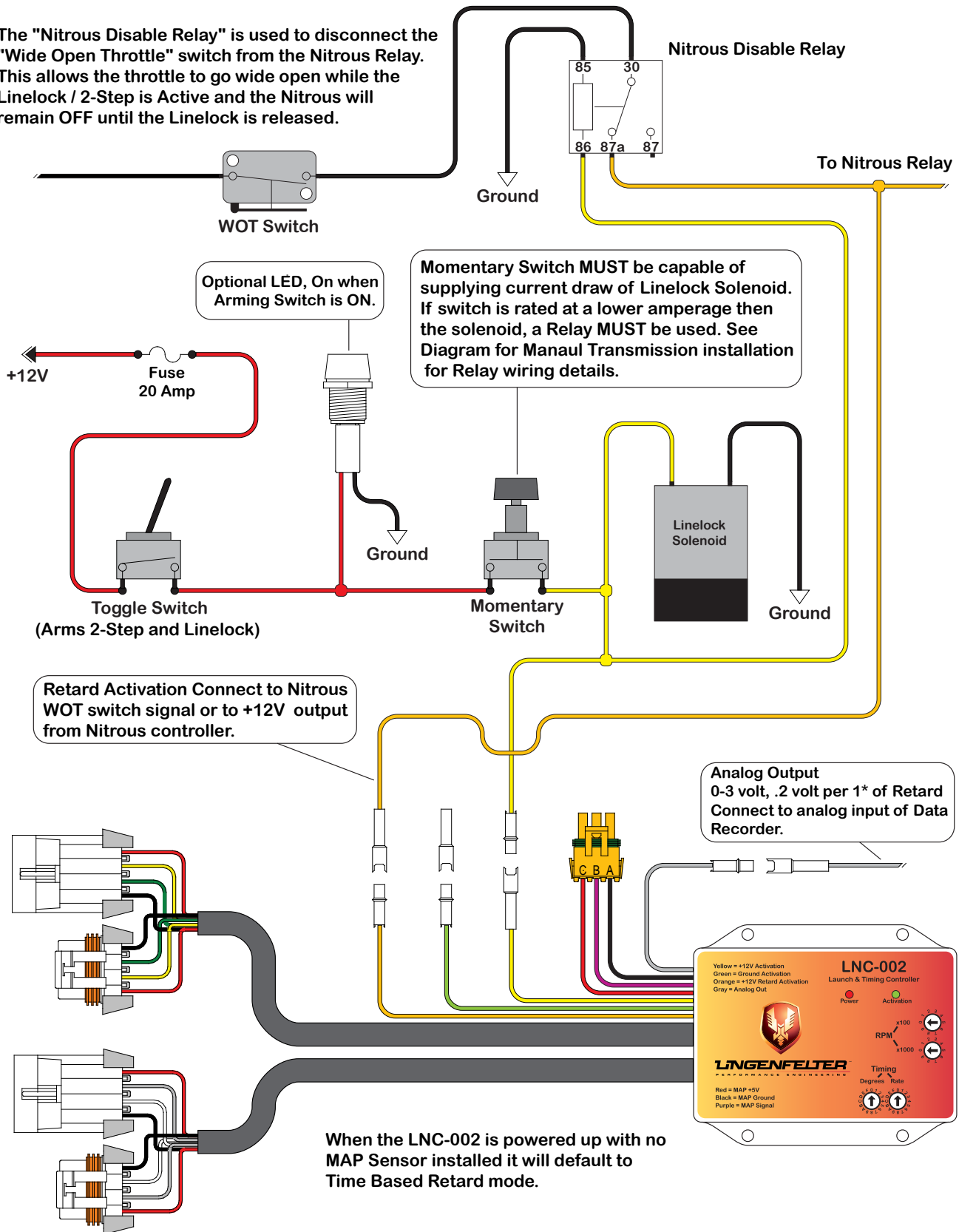

Automatic Transmission with Linelock & Boost Retard

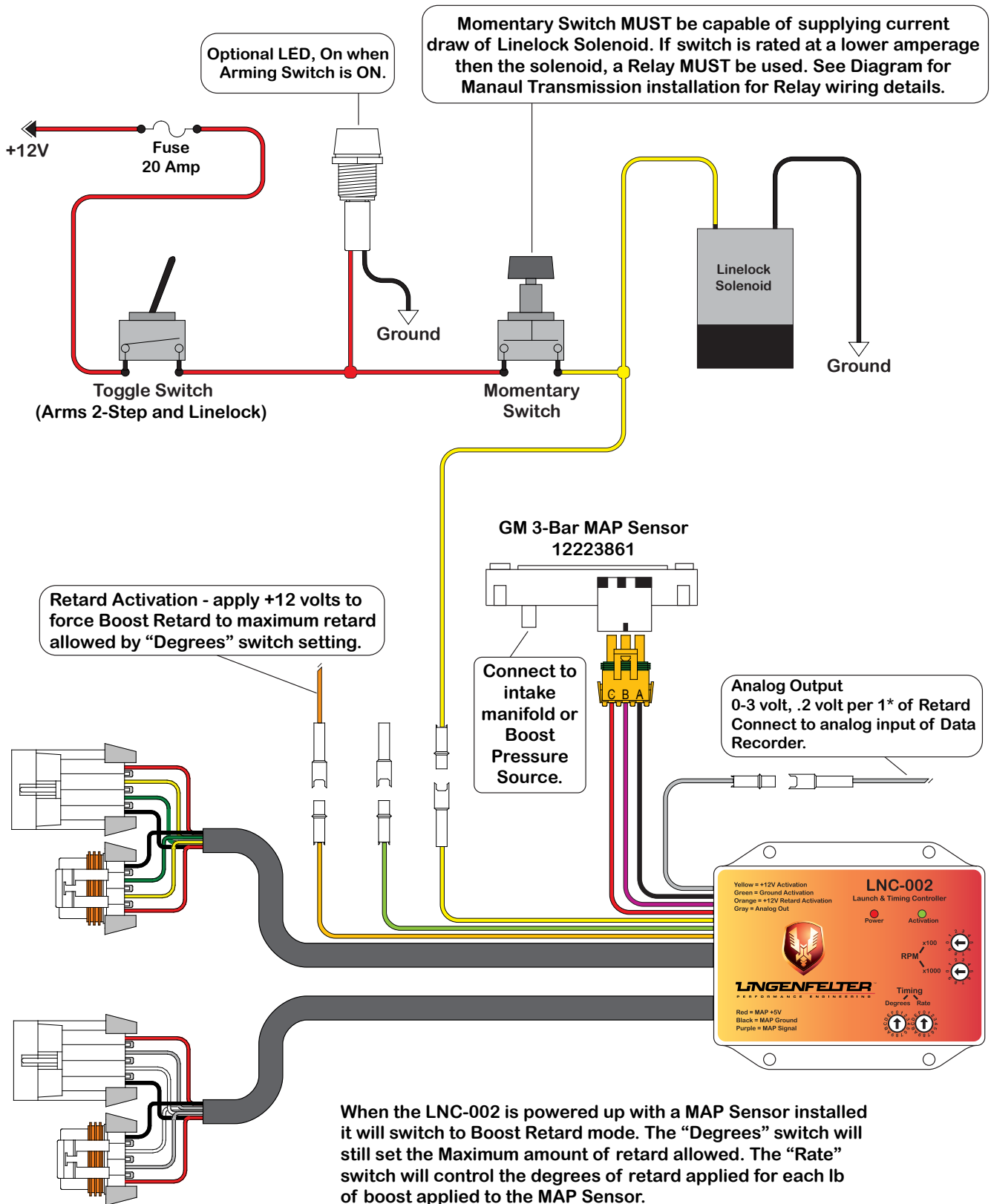

LNC-002 Wiring Diagram

Harness #1

Harness #2

Cut harness wires 50" in length.
Finished trim length = 48"
20 Gauge

Cut Wire Loom 42" Long

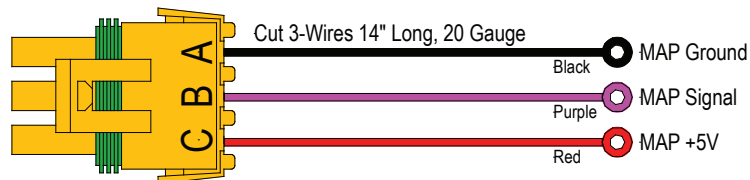
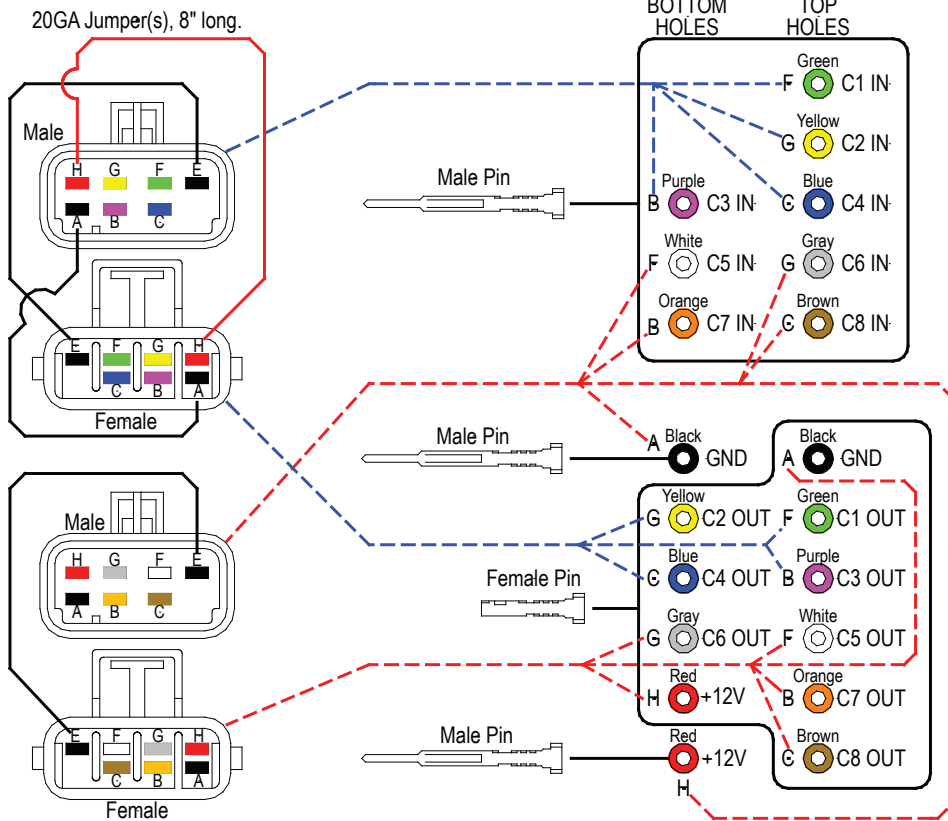
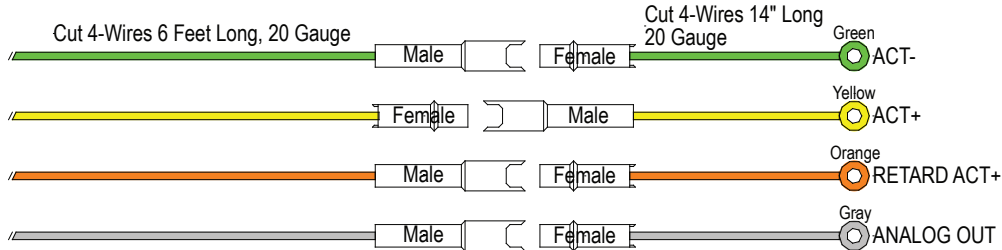

- **Vehicle applications:**

The LNC-002 is designed for use on all known GM LS series engine applications (LS1, LS6, LS2, LS7, LS3, LQ4, L76, L92 and other Gen III and IV GM V8 applications along with other GM V8 engines using the same ignition coil system) including the following vehicles:

- 1997-2004 C5 Corvette
- 2005-2009 C6 Corvette (including Z06)
- 1998-2002 LS1 V8 equipped Camaro and Firebird
- 2004-2006 Pontiac GTO
- 2008-2009 Pontiac G8 with the L76 or the LS3 engine
- 2004-2006 Cadillac CTS-V
- 1999-2008 GM CK trucks (Tahoe, Yukon, Escalade, H2, Sierra, Silverado, Avalanche) with the 4.8, 5.3, 6.0 and 6.2L Gen III and IV V8 engines (will not work on 305 & 350 Vortec engines)
- 2003-2006 Chevrolet SSR
- 2006-2008 Trailblazer SS and other S/T body trucks with the 4.8, 5.3 and 6.0L Gen III & IV GM V8 engines

The LNC-002 should function on the following vehicles/engines but has not yet been tested on them:

- CK trucks with 8.1L V8 engines (L19) with individual coil ignitions
- front wheel drive 5.3L LS4 Gen IV V8 equipped cars (Impala SS, Grand Prix & Monte Carlo)

The LNC-002 should also function with these products but has not yet been tested with them:

- aftermarket coils for the LS series engines (such as the MSD coils) used with GM ECM/PCM.
- aftermarket engine management systems and ignition systems (Accel, BigStuff3, Motec, FAST, MSD, etc.) that run the production GM coils.

The LNC-002 can be used on the 2009-2010 ZR1 Corvette (LS9 engine) and the 2009-2010 Cadillac CTSV (LSA engine) but you will need to change the connectors because the LS9 and the LSA use a different combined coil and fuel injector harness. Contact LPE for these connectors (part #s 15336037, 15422562, 15326939, 15336034).

The LNC-002 will NOT work with other individual coil ignition systems like those found on the GM Northstar or Ecotec engines or on the Ford modular V8 and the Chrysler Hemi V8.

LINGENFELTER

P E R F O R M A N C E E N G I N E E R I N G

NOTICES:

It is the responsibility of the purchaser to follow all guidelines and safety procedures supplied with this product and any other manufactures product used with this product. It is also the responsibility of the purchaser to determine compatibility of this device with the vehicle and other components.

Lingenfelter Performance Engineering assumes no responsibility for damages resulting from accident, improper installation, misuse, abuse, improper operation, lack of reasonable care, or all previously stated reasons due to incompatibility with other manufacturer's products.

Lingenfelter Performance Engineering assumes no responsibility or liability for damages incurred from the use of products manufactured or sold by Lingenfelter Performance Engineering on vehicles used for competition racing. Lingenfelter Performance Engineering neither recommends nor approves the use of products manufactured or sold by Lingenfelter Performance Engineering on vehicles which may be driven on public highways or roads, and assumes no responsibility for damages incurred from such use.

It is the purchaser's responsibility to check the state and local laws and sanctioning body requirements pertaining to the use of this product for racing applications. Lingenfelter Performance Engineering does not recommend nor condone the use of its products for illegal street racing.

Limited Warranty:

LPE warrants the Lingenfelter LNC-002 Launch Control Module to be free from defects in material and workmanship under normal use and if properly installed for a period of 90 days from date of purchase. If the module is found to be defective as mentioned above, it will be replaced or repaired if returned prepaid along with proof of date of purchase. This shall constitute the sole remedy of the purchaser and the sole liability of LPE. To the extent permitted by law, the foregoing is exclusive and in lieu of all other warranties or representations whether expressed or implied, including any implied warranty of merchantability or fitness. In no event shall LPE be liable for special or consequential damages.

1557 Winchester Road
Decatur, Indiana 46733
260 724 2552 phone
260 724 8761 fax
www.lingenfelter.com